



Chipsmall Limited consists of a professional team with an average of over 10 year of expertise in the distribution of electronic components. Based in Hongkong, we have already established firm and mutual-benefit business relationships with customers from,Europe,America and south Asia,supplying obsolete and hard-to-find components to meet their specific needs.

With the principle of “Quality Parts,Customers Priority,Honest Operation,and Considerate Service”,our business mainly focus on the distribution of electronic components. Line cards we deal with include Microchip,ALPS,ROHM,Xilinx,Pulse,ON,Everlight and Freescale. Main products comprise IC,Modules,Potentiometer,IC Socket,Relay,Connector.Our parts cover such applications as commercial,industrial, and automotives areas.

We are looking forward to setting up business relationship with you and hope to provide you with the best service and solution. Let us make a better world for our industry!



## Contact us

Tel: +86-755-8981 8866 Fax: +86-755-8427 6832

Email & Skype: info@chipsmall.com Web: www.chipsmall.com

Address: A1208, Overseas Decoration Building, #122 Zhenhua RD., Futian, Shenzhen, China





**INSTRUCTION MANUAL  
MANUAL DE INSTRUCCIONES  
MANUEL D'INSTRUCTIONS**

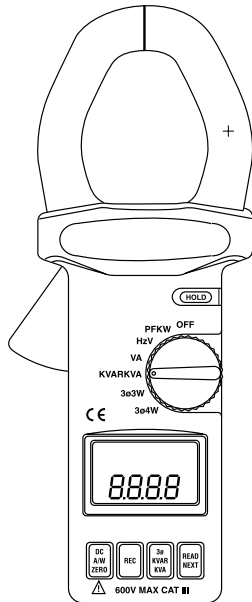

**CMP-200  
DIGITAL CLAMP-ON  
METER  
MEDIDOR DIGITAL  
CON PINZA  
COMPTEUR  
NUMERIQUE A  
PINCES**



**Read and understand** all of the instructions and safety information in this manual before operating or servicing this tool.

**Lea y entienda** todas las instrucciones y la información sobre seguridad que aparecen en este manual, antes de manejar estas herramientas o darles mantenimiento.

**Lire attentivement et bien comprendre** toutes les instructions et les informations sur la sécurité de ce manuel avant d'utiliser ou de procéder à l'entretien de cet outil.



## Description

The Greenlee CMP-200 is a Digital Clamp-on Meter intended to measure true power (watts), apparent power (volt-amps), reactive power (volt-amps reactive) and power factor in single-phase and three-phase circuits. It also measures voltage, current and frequency.

## Safety



Safety is essential in the use and maintenance of Greenlee tools and equipment. This instruction manual and any markings on the tool provide information for avoiding hazards and unsafe practices related to the use of this tool. Observe all of the safety information provided.

## Purpose

This instruction manual is intended to familiarize all personnel with the safe operation and maintenance procedures for the Greenlee CMP-200.

Keep this manual available to all personnel.

Replacement manuals are available upon request at no charge.

 and  **GREENLEE** are registered trademarks of Greenlee Textron.



***KEEP THIS MANUAL***





## Important Safety Information



### SAFETY ALERT SYMBOL

This symbol is used to call your attention to hazards or unsafe practices which could result in an injury or property damage. The signal word, defined below, indicates the severity of the hazard. The message after the signal word provides information for preventing or avoiding the hazard.

#### **▲ DANGER**

Immediate hazards which, if not avoided, WILL result in severe injury or death.

#### **▲ WARNING**

Hazards which, if not avoided, COULD result in severe injury or death.

#### **▲ CAUTION**

Hazards or unsafe practices which, if not avoided, MAY result in injury or property damage.



#### **▲ WARNING**

**Read and understand** this material before operating or servicing this equipment. Failure to understand how to safely operate this tool can result in an accident causing serious injury or death.





## Important Safety Information



### **▲WARNING**

Electric shock hazard:  
Contact with live circuits can result in severe injury or death.

### **▲WARNING**

Electric shock hazard:

- Do not use the unit if it is wet or damaged.
- Use test leads or accessories that are appropriate for the application. See the category and voltage rating of the test lead or accessory.
- Inspect the test leads or accessory before use. They must be clean and dry, and the insulation must be in good condition.

Failure to observe these warnings can result in severe injury or death.

### **▲WARNING**

Electric shock hazard:

- Do not apply more than the rated voltage between any two input terminals, or between any input terminal and earth ground.
- Do not contact the test lead tips or any uninsulated portion of the accessory.

Failure to observe these warnings can result in severe injury or death.



CMP-200

## Important Safety Information

### **▲WARNING**

- Do not operate with the case open.
- Before opening the case, remove the test leads (or jaw) from the circuit and shut off the unit.

Failure to observe these warnings can result in severe injury or death.

### **▲CAUTION**

Do not change the measurement function while the test leads are connected to a component or circuit.

Failure to observe this precaution can result in injury and can damage the unit.

### **▲CAUTION**

- Do not attempt to repair this unit. It contains no user-serviceable parts.
- Do not expose the unit to extremes in temperature or high humidity.  
See Specifications.

Failure to observe these precautions can result in injury and can damage the unit.

### **IMPORTANT**

Using this unit near equipment that generates electromagnetic interference can result in unstable or inaccurate readings.



## Glossary

<b>PF</b>	Power Factor
<b>Ø</b>	Phase
<b>W</b>	Wire
<b>W</b>	Watts (True Power)
<b>VA</b>	Volt-Amps (Apparent Power)
<b>VAR</b>	Volt-Amps Reactive (Reactive Power)

## Identification

1. Lever
2. Jaw
3. Hold Button
4. Selector
5. Display
6. READ NEXT Button
7. 3Ø KVAR KVA Button
8. REC Button
9. DC A/W ZERO Button
10. + Terminal
11. COM Terminal

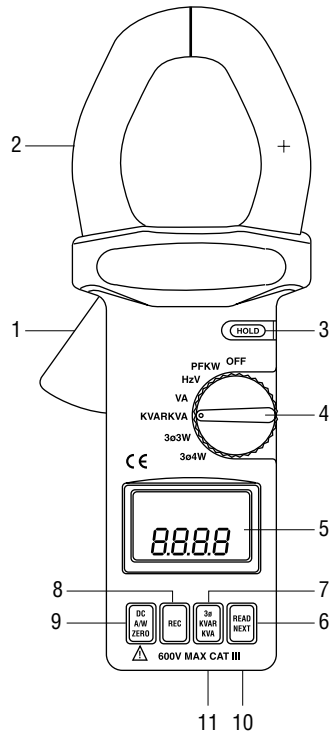







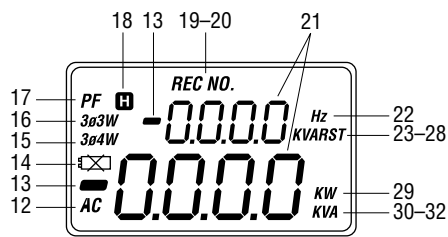

### Display Icons

- 12. AC Alternating Current
- 13. - Polarity Indicator
- 14.  Low Battery
- 15. 3Ø4W Three-Phase Four-Wire Circuits
- 16. 3Ø3W Three-Phase Three-Wire Circuits
- 17. PF Power Factor
- 18. H Hold
- 19. REC Indicates that data is stored in memory
- 20. REC NO. Indicates that stored data is on the display  
(1, 2, 3 or 4)
- 21. 0.0.0.0 Numeric Display
- 22. Hz Frequency (in Hertz or cycles per second)
- 23. K Kilo (10<sup>3</sup>)
- 24. V Volts
- 25. A Amps
- 26. R First Phase
- 27. S Second Phase
- 28. T Third Phase
- 29. KW Kilowatt
- 30. K Kilo (10<sup>3</sup>)
- 31. V Volts
- 32. A Amps
- OL Overload (not shown)



### Symbols on the Unit

-  Read the instruction manual.
-  Double Insulation
-  Battery





## Using the Features

- **HOLD** Press momentarily to hold the present value on the display and store it in the memory. Press again to exit this mode.
- **DC A/W ZERO Button** Sets the meter to zero to eliminate the effects of residual magnetism when measuring DC current, power and power factor.
- **REC Button** Press to store data in memory; the CMP-200 has four memory locations. FULL indicates that all memory locations are in use. Shut the meter off to clear all of the memories.
- **3Ø KVAR KVA** After the 3Ø3W or 3Ø4W function has finished calculations, press this button to toggle between power factor (PF)/true power (W) display and reactive power (VAR)/apparent power (VA) display.
- **READ NEXT Button** When taking current and voltage measurements from 3Ø3W or 3Ø4W circuits, use this button for storing data and performing calculations.

When measuring any other value, use this button to recall data stored in the four memory locations. REC NO. 1 will appear momentarily on the display, followed by the value stored in the first memory. Change the selector to any position to exit the READ mode.



## AC Measurement





AC measurements are usually displayed as RMS (*root mean squared*) values. Two methods of AC measurement are *average-responding RMS calibrated* and *true RMS-reading*.

The average-responding RMS calibrated method takes the average value of the input signal, multiplies it by 1.11, and displays the result. This method is accurate if the input signal is a pure sine wave.

The true RMS-reading method uses internal circuitry to read the true RMS value. This method is accurate, within the specified crest factor limitations, whether the input signal is a pure sine wave, a square wave, sawtooth, half wave or signal with harmonics. The ability to read true RMS provides much more measurement versatility. The Greenlee CMP-200 is a true RMS meter.

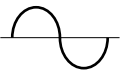
The Waveforms and Crest Factors table shows some typical AC signals and their RMS values.

### Waveforms and Crest Factors

<b>Waveform</b>				
<b>RMS Value</b>	100	100	100	100
<b>Average Value</b>	90	100	87	64
<b>Crest Factor* (<math>\xi</math>)</b>	1.414	1	1.73	2

\* The crest factor is the ratio of the peak value to the RMS value; it is represented by the Greek letter  $\xi$ .





## Operation

	<b>⚠ WARNING</b>
	Electric shock hazard: Contact with live circuits can result in severe injury or death.

1. See the Settings Tables. Set the selector to the proper setting and connect the test leads to the meter.
2. See the appropriate section for specific measurement instructions and illustrations.
3. Test the unit on a known functioning circuit or component.
  - If the unit does not function as expected on a known functioning circuit, replace the battery and/or fuse.
  - If the unit still does not function as expected, send the unit to Greenlee for repair.
4. Take the reading from the circuit or component to be tested.

## Measurements on Single-Phase Circuits

### Single-Phase Two-Wire Circuits: Settings Table

Measurement	Selector Setting	Icons Displayed	Red Lead Connection	Black Lead Connection	Clamp Location
Voltage or Frequency	<b>Hz V</b>	Hz and V	hot or neutral	hot or neutral	N/A
Watts and Power Factor* (W and PF)	<b>PF KW</b> and press <b>DCA/W ZERO</b>	PF and KW	hot	neutral	hot
Apparent and Reactive Power (KVA and KVAR)	<b>KVAR KVA</b> and press <b>DCA/W ZERO</b>	KVAR and KVA	hot	neutral	hot
Current or Voltage	<b>VA</b>	V and A	hot	neutral	hot

\* A positive (+) PF indicates an inductive load. A negative (-) PF indicates a capacitive load. If the PF is greater than 0.91 (a phase shift of less than 25°), set the selector to 3Ø3W for a more accurate reading of KVA and KVAR.



CMP-200

## Measurements on Single-Phase Circuits (cont'd)

Single-Phase Two-Wire Circuits:  
Voltage or Frequency Measurement

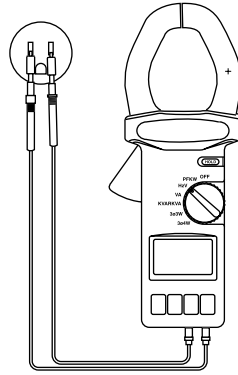

Single-Phase Two-Wire Circuits: True Power, Power Factor, Apparent Power and  
Reactive Power Measurement or Current and Voltage Measurement

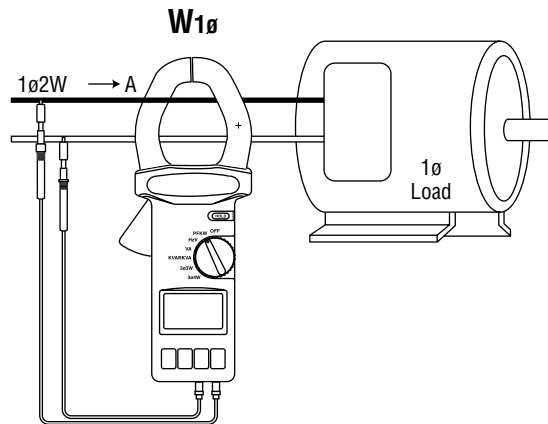



## Measurements on Single-Phase Circuits (cont'd)

### Single-Phase Three-Wire Circuits: Settings Table

<b>Measurement:</b> True Power, Power Factor*, Apparent Power and Reactive Power (W, PF, KVA, KVAR) <b>Type of Circuit:</b> 1 $\phi$ 3W <b>Selector Setting:</b> 3 $\phi$ 3W			
Instructions	Red Lead Connection	Black Lead Connection	Clamp Location
"R" will flash on the display. Press <b>DCA/W ZERO**</b> . Connect the leads and position the clamp as shown to take the first measurement ( $W_{RS}$ / $KVAR_{RS}$ ).	L1	Neutral	L1
After the measurement stabilizes, press <b>READ NEXT</b> . "T" will flash on the display. Remove clamp from wire. Press <b>DCA/W ZERO**</b> and connect the leads and position the clamp as shown to take the final measurement ( $W_{TS}$ / $KVAR_{TS}$ ).	L2	Neutral	L2
After the final measurement stabilizes, press <b>READ NEXT</b> . The CMP-200 will calculate and display the power factor (PF) and true power (W). Press <b>3<math>\phi</math> KVAR KVA</b> to display the reactive power (KVAR) and apparent power (KVA).			

\* A positive (+) PF indicates an inductive load. A negative (-) PF indicates a capacitive load. Power factor value is correct for balanced loads only.

\*\* Jaw should be closed and removed from circuit whenever DCA/W ZERO is pressed.

*Note: The + sign on the jaw must face the power source.*



CMP-200

## Measurements on Single-Phase Circuits (cont'd)

### Single-Phase Three-Wire Circuits: Voltage or Frequency Measurement

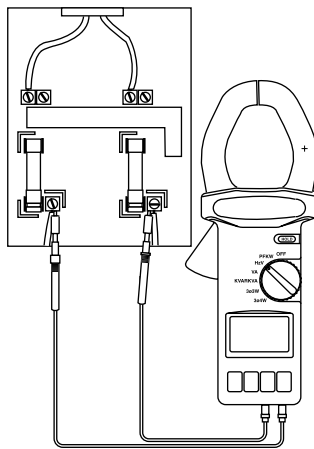



## Measurements on Single-Phase Circuits (cont'd)

### Single-Phase Three-Wire Circuits:

### True Power, Power Factor, Apparent Power and Reactive Power Measurement

#### WL1 (WRS)

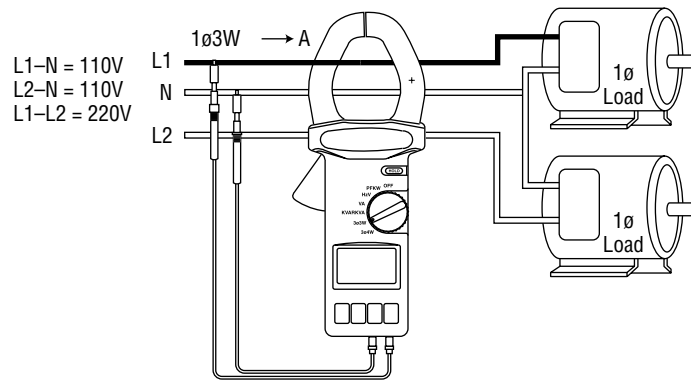

#### WL2 (WTS)

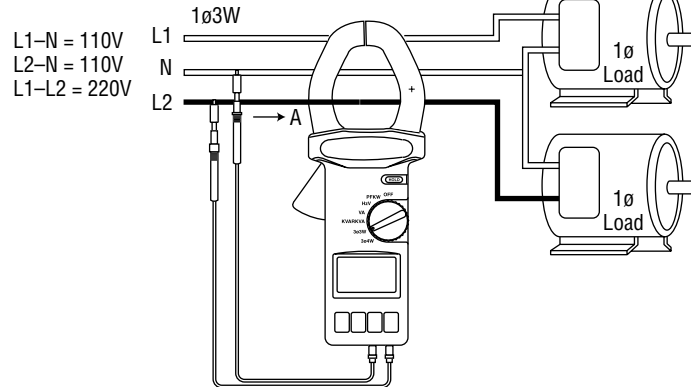





## Measurements on Three-Phase Circuits

The branches or legs of three phase electrical circuits are typically labeled in any of the following conventions:

- A, B and C
- L1, L2 and L3
- R, S, and T

They are referred to as R, S and T in this manual and on the meter.

### Three-Phase Circuits: Settings Table for Voltage and Frequency

Measurement	Type of Circuit	Selector Setting	Icons Displayed	Red Lead Connection	Black Lead Connection	Clamp Location
Voltage or Frequency	3 $\phi$ 3W or 3 $\phi$ 4W	Hz V	Hz and V	R, S or T	any other phase (or neutral on 3 $\phi$ 4W only)	N/A



### Three-Phase Circuits: Voltage or Frequency Measurement

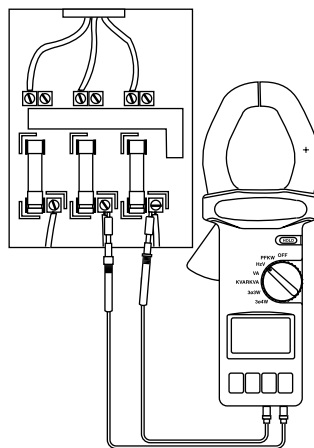



## Measurements on Three-Phase Circuits (cont'd)

### Three-Phase Three-Wire Circuits: Settings Table for Power Measurements

<b>Measurement:</b> True Power, Power Factor*, Apparent Power and Reactive Power (W, PF, KVA and KVAR) <b>Type of Circuit:</b> 3 $\phi$ 3W <b>Selector Setting:</b> 3 $\phi$ 3W			
Instructions	Red Lead Connection	Black Lead Connection	Clamp Location
"R" will flash on the display. Press <b>DCA/W ZERO**</b> . Connect the leads and position the clamp as shown to take the first measurement ( $W_{RS}$ / $KVAR_{RS}$ ).	R	S	R
After the measurement stabilizes, press <b>READ NEXT</b> . "T" will flash on the display. Remove clamp from wire. Press <b>DCA/W ZERO**</b> and connect the leads and position the clamp as shown to take the final measurement ( $W_{TS}$ / $KVAR_{TS}$ ).	T	S	T
After the final measurement stabilizes, press <b>READ NEXT</b> . The CMP-200 will calculate and display the power factor (PF) and true power (W). Press <b>3<math>\phi</math> KVAR KVA</b> to display the reactive power (KVAR) and apparent power (KVA).			

\* A positive (+) PF indicates an inductive load. A negative (-) PF indicates a capacitive load. Power factor value is correct for balanced loads only.

\*\* Jaw should be closed and removed from circuit whenever DCA/W ZERO is pressed.

#### Notes:

- The + sign on the jaw must face the power source.
- COM connection (black lead) should remain connected to the same phase during both measurements.
- Both power measurements may be positive, or one may be negative. Make sure all connections are correct to obtain proper measurements.



CMP-200

## Measurements on Three-Phase Circuits (cont'd)

**Three-Phase Three-Wire Measurements:  
True Power, Power Factor, Apparent Power and Reactive Power Measurement**

### Wrs

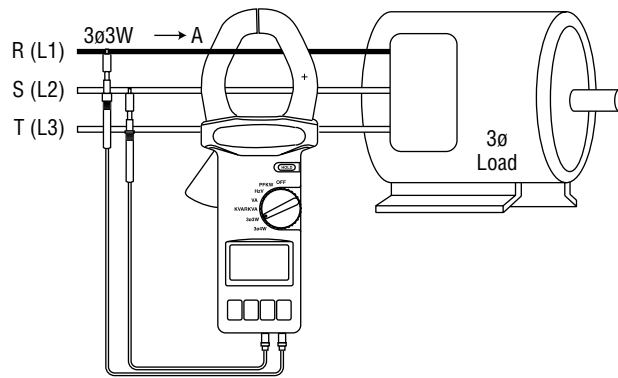

### Wts

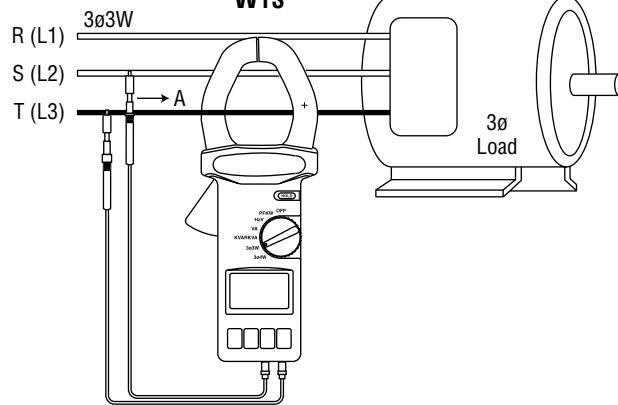



## Measurements on Three-Phase Circuits (cont'd)

### Three-Phase Four-Wire Circuits: Settings Table

<b>Measurement:</b> True Power, Power Factor*, Apparent Power and Reactive Power (W, PF, KVA and KVAR) <b>Type of Circuit:</b> 3 $\phi$ 4W <b>Selector Setting:</b> 3 $\phi$ 4W			
Instructions	Red Lead Connection	Black Lead Connection	Clamp Location
"R" will flash on the display. Press <b>DCA/W ZERO**</b> . Connect the leads and position the clamp as shown to take the first measurement ( $W_R / PF_R$ ).	R	N	R
After the measurement stabilizes, press <b>READ NEXT</b> . "S" will flash on the display. Remove clamp from wire. Press <b>DCA/W ZERO**</b> and connect the leads and position the clamp as shown to take the final measurement ( $W_S / PF_S$ ).	S	N	S
After the measurement stabilizes, press <b>READ NEXT</b> . "T" will flash on the display. Remove clamp from wire. Press <b>DCA/W ZERO**</b> and connect the leads and position the clamp as shown to take the final measurement ( $W_T / PF_T$ ).	T	N	T
After the final measurement stabilizes, press <b>READ NEXT</b> . The CMP-200 will calculate and display the power factor (PF) and true power (W). Press <b>3<math>\phi</math> KVAR KVA</b> to display the reactive power (KVAR) and apparent power (KVA).			

\* A positive (+) PF indicates an inductive load. A negative (-) PF indicates a capacitive load. Power factor value is correct for balanced loads only.

\*\* Jaw should be closed and removed from circuit whenever DCA/W ZERO is pressed.

#### Notes:

- The + sign on the jaw must face the power source.
- All three power measurements ( $W_R$ ,  $W_S$  and  $W_T$ ) should be positive. Check test lead connection and clamping of jaw if any power measurement is negative.



## Measurements on Three-Phase Circuits (cont'd)

**Three-Phase Four-Wire Measurements: True Power, Power Factor, Apparent Power and Reactive Power Measurement**

**WR (L1)**

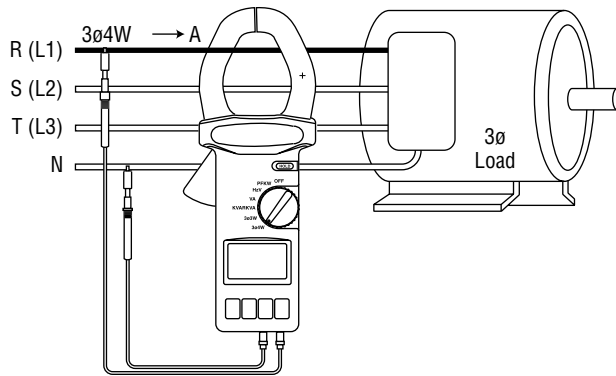

**Ws (L2)**

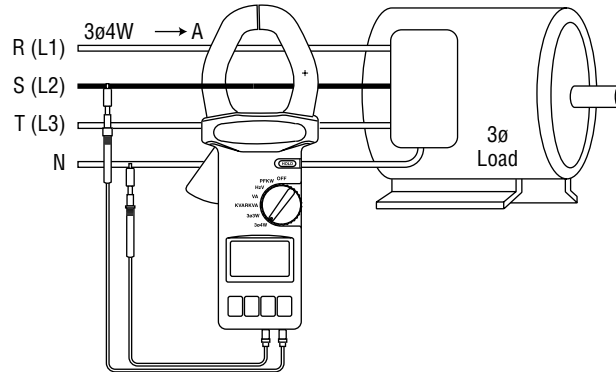



## Measurements on Three-Phase Circuits (cont'd)

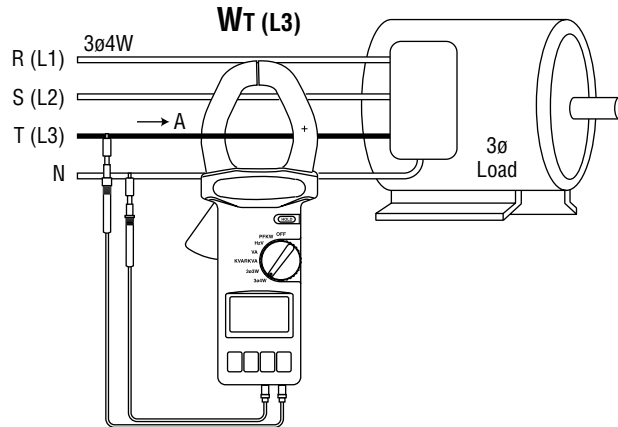

### Calculations

When using the 3Ø3W and 3Ø4W functions of the CMP-200, the unit automatically performs the following calculations:

#### Single-Phase

$$W_{1Ø3W} = W_{L1L2N} = W_{L1N} + W_{L2N}$$

#### Three-Phase Three-Wire

$$W_{3Ø3W} = W_{RS} + W_{TS}$$

$$KVAR_{3Ø3W} = KVAR_{RS} + KVAR_{TS}$$

$$KVA_{3Ø3W} = \sqrt{[KW_{3Ø3W}]^2 + [KVAR_{3Ø3W}]^2}$$

$$PF_{3Ø3W} = \frac{KW_{3Ø3W}}{KVA_{3Ø3W}}$$

#### Three-Phase Four-Wire

$$W_{3Ø4W} = W_R + W_S + W_T$$

$$KVAR_{3Ø4W} = KVAR_R + KVAR_S + KVAR_T$$

$$KVA_{3Ø4W} = \sqrt{[KW_{3Ø4W}]^2 + [KVAR_{3Ø4W}]^2}$$

$$PF_{3Ø4W} = \frac{KW_{3Ø4W}}{KVA_{3Ø4W}}$$





### Accuracy

Accuracy is specified as follows:  $\pm$  (a percentage of the reading + a fixed amount) at 18 °C to 28 °C (64.4 °F to 82.4 °F).

Accuracy Table

Value	Measurement Range	Accuracy	
**Frequency	50/60 Hz	$\pm$ (2 d)*	
	10 Hz to 1000 Hz	$\pm$ (1.5% + 2 d)*	
†True Power (AC or DC)	0 to 99.99 KW	$\pm$ (2% + 0.05 KW)	
	100 to 999.9 KW	$\pm$ (2% + 0.5 KW)	
	1000 to 1200 KW	$\pm$ (2% + 5 KW)	
†KVAR (AC or DC)	0 to 99.99 KW	$\pm$ (2% + 0.05 KW)	
	100 to 999.9 KW	$\pm$ (2% + 0.5 KW)	
	1000 to 1200 KW	$\pm$ (2% + 5 KW)	
		<b>at 0 Hz and 50/60 Hz</b>	<b>at 40 Hz to 400 Hz</b>
††Voltage (AC or DC) at 10 mΩ Input Impedance	0 to 499.9 V	$\pm$ (1.5% + 0.5 V)	$\pm$ (2.0% + 0.5 V)
	500 to 600 V	$\pm$ (1.5% + 5 V)	$\pm$ (2.0% + 5 V)
††Current (AC or DC)	0 to 199.9 A	$\pm$ (1.5% + 0.5 A)	$\pm$ (2.0% + 0.5 A)
	200 to 499.9 A	$\pm$ (2.0% + 0.5 A)	$\pm$ (2.5% + 0.5 A)
	500 to 2000 A	$\pm$ (2.0% + 5 A)	$\pm$ (2.5% + 5 A)

\* d refers to the least significant digit (the number in the right-most position)

\*\* Sensitivity: Volts > 1 V; Amps > 5 A

Minimum Input Frequency: 10 Hz

† Maximums: 600 V, 2000 Amps

Power Factor: 0.2 to 1.0

†† Accuracy specified for crest factor less than 4





## Specifications

Display: Dual 4-digit LCD (9999 maximum count)

Polarity: Automatic

Sampling Rate:

Volts and Amps: 2 per second

Watts: 0.6 per second

Jaw Opening: 55 mm (2.17")

Operating Conditions: 4 °C to 50 °C (39.2 °F to 122 °F) , 0 to 85% relative humidity

Elevation: 2000 m (6500') maximum

Storage Conditions: -20 °C to 60 °C (-4 °F to 140 °F), 0 to 75% relative humidity

Remove battery.

Battery: 9-Volt battery (NEDA 1604, JIS 006P or IEC 6F22)

Overvoltage Protection: Category III, 600 Volts



## Cleaning

Periodically wipe the case with a damp cloth and mild detergent; do not use abrasives or solvents.





CMP-200

## Descripción

El Medidor digital con pinza modelo CMP-200 de Greenlee está diseñado para medir potencia real (vatios), potencia aparente (voltiamperios), potencia reactiva (voltiamperios reactivos) y factor de potencia en circuitos monofásicos y trifásicos. También sirve para medir tensión, corriente y frecuencia.

## Acerca de la seguridad

Es fundamental observar métodos seguros al utilizar y dar mantenimiento a las herramientas y equipo Greenlee. Este manual de instrucciones y todas las marcas que ostenta la herramienta le ofrecen la información necesaria para evitar riesgos y hábitos poco seguros relacionados con su uso. Siga toda la información sobre seguridad que se proporciona.

## Propósito de este manual

Este manual de instrucciones tiene como propósito familiarizar a todo el personal con los procedimientos de operación y mantenimiento seguros para la unidad CMP-200 de Greenlee.

Manténgalo siempre al alcance de todo el personal.

Puede obtener copias adicionales de manera gratuita, previa solicitud.



**GREENLEE** son marcas registradas de Greenlee Textron.



**CONSERVE ESTE MANUAL**





## Importante Información sobre Seguridad



### SÍMBOLO DE ALERTA SOBRE SEGURIDAD

Este símbolo se utiliza para indicar un riesgo o práctica poco segura que podría ocasionar lesiones o daños materiales. Cada uno de los siguientes términos denota la gravedad del riesgo. El mensaje que sigue a dichos términos le indica cómo puede evitar o prevenir ese riesgo.

#### PELIGRO

Peligros inmediatos que, de no evitarse, OCASIONARÁN graves lesiones o incluso la muerte.

#### ADVERTENCIA

Peligros que, de no evitarse, PODRÍAN OCASIONAR graves lesiones o incluso la muerte.

#### PRECAUCIÓN

Peligro o prácticas peligrosas que, de no evitarse, PUEDEN OCASIONAR lesiones o daños materiales.



#### ADVERTENCIA

**Lea y entienda** este documento antes de manejar esta herramienta o darle mantenimiento. Utilizarla sin comprender cómo manejarla de manera segura podría ocasionar un accidente y, como resultado de éste, graves lesiones o incluso la muerte.





CMP-200

## Importante Información sobre Seguridad



### ⚠ADVERTENCIA

Peligro de electrocución:

El contacto con circuitos activados puede ocasionar graves lesiones o incluso la muerte.

### ⚠ADVERTENCIA

Peligro de electrocución:

- No utilice esta unidad si se encuentra mojada o dañada.
- Utilice cables de prueba y accesorios que sean apropiados para la aplicación que se va a realizar. Consulte la información sobre categoría y voltaje nominal del cable de prueba o el accesorio.
- Revise minuciosamente los cables de prueba o el accesorio, antes de utilizarlos. Deberán estar limpios y secos, y su forro aislante deberá hallarse en buenas condiciones.

De no observarse estas advertencias pueden sufrirse graves lesiones o incluso la muerte.

### ⚠ADVERTENCIA

Peligro de electrocución:

- No aplique más del voltaje nominal entre dos terminales de entrada cualesquiera, o entre una terminal de entrada cualquiera y una conexión a tierra.
- No toque las puntas de los cables de prueba ni ninguna parte del accesorio que carezca de forro aislante.

De no observarse estas advertencias pueden sufrirse graves lesiones o incluso la muerte.