



Chipsmall Limited consists of a professional team with an average of over 10 year of expertise in the distribution of electronic components. Based in Hongkong, we have already established firm and mutual-benefit business relationships with customers from,Europe,America and south Asia,supplying obsolete and hard-to-find components to meet their specific needs.

With the principle of “Quality Parts,Customers Priority,Honest Operation,and Considerate Service”,our business mainly focus on the distribution of electronic components. Line cards we deal with include Microchip,ALPS,ROHM,Xilinx,Pulse,ON,Everlight and Freescale. Main products comprise IC,Modules,Potentiometer,IC Socket,Relay,Connector.Our parts cover such applications as commercial,industrial, and automotives areas.

We are looking forward to setting up business relationship with you and hope to provide you with the best service and solution. Let us make a better world for our industry!



Contact us

Tel: +86-755-8981 8866 Fax: +86-755-8427 6832

Email & Skype: info@chipsmall.com Web: www.chipsmall.com

Address: A1208, Overseas Decoration Building, #122 Zhenhua RD., Futian, Shenzhen, China



CMPT3646
SURFACE MOUNT
NPN SILICON TRANSISTOR



SOT-23 CASE



www.centrasemi.com

DESCRIPTION:

The CENTRAL SEMICONDUCTOR CMPT3646 type is an NPN silicon transistor manufactured by the epitaxial planar process, epoxy molded in a surface mount package, designed for ultra high speed switching applications.

MARKING CODE: C2R

MAXIMUM RATINGS: ($T_A=25^\circ\text{C}$)

Collector-Base Voltage
Collector-Emitter Voltage
Collector-Emitter Voltage
Emitter-Base Voltage
Continuous Collector Current
Power Dissipation
Operating and Storage Junction Temperature
Thermal Resistance

SYMBOL		UNITS
V_{CBO}	40	V
V_{CES}	40	V
V_{CEO}	15	V
V_{EBO}	5.0	V
I_C	200	mA
P_D	350	mW
T_J, T_{stg}	-65 to +150	$^\circ\text{C}$
Θ_{JA}	357	$^\circ\text{C/W}$

ELECTRICAL CHARACTERISTICS: ($T_A=25^\circ\text{C}$ unless otherwise noted)

SYMBOL	TEST CONDITIONS	MIN	MAX	UNITS
I_{CES}	$V_{CE}=20V$		0.5	μA
I_{CES}	$V_{CE}=20V, T_A=65^\circ\text{C}$		3.0	μA
BV_{CBO}	$I_C=100\mu\text{A}$	40		V
BV_{CES}	$I_C=10\mu\text{A}$	40		V
BV_{CEO}	$I_C=10\text{mA}$	15		V
BV_{EBO}	$I_E=100\mu\text{A}$	5.0		V
$V_{CE(SAT)}$	$I_C=30\text{mA}, I_B=3.0\text{mA}$		0.20	V
$V_{CE(SAT)}$	$I_C=30\text{mA}, I_B=3.0\text{mA}, T_A=65^\circ\text{C}$		0.30	V
$V_{CE(SAT)}$	$I_C=100\text{mA}, I_B=10\text{mA}$		0.28	V
$V_{CE(SAT)}$	$I_C=300\text{mA}, I_B=30\text{mA}$		0.50	V
$V_{BE(SAT)}$	$I_C=30\text{mA}, I_B=3.0\text{mA}$	0.75	0.95	V
$V_{BE(SAT)}$	$I_C=100\text{mA}, I_B=10\text{mA}$		1.20	V
$V_{BE(SAT)}$	$I_C=300\text{mA}, I_B=30\text{mA}$		1.70	V
h_{FE}	$V_{CE}=0.4V, I_C=30\text{mA}$	30	120	
h_{FE}	$V_{CE}=0.5V, I_C=100\text{mA}$	25		
h_{FE}	$V_{CE}=1.0V, I_C=300\text{mA}$	15		

CMPT3646
SURFACE MOUNT
NPN SILICON TRANSISTOR



ELECTRICAL CHARACTERISTICS - Continued: ($T_A=25^\circ\text{C}$ unless otherwise noted)

SYMBOL	TEST CONDITIONS	MIN	MAX	UNITS
f_T	$V_{CE}=10\text{V}$, $I_C=30\text{mA}$, $f=100\text{MHz}$	350		MHz
C_{ob}	$V_{CB}=5.0\text{V}$, $I_E=0$, $f=1.0\text{MHz}$		5.0	pF
C_{ib}	$V_{BE}=0.5\text{V}$, $I_C=0$, $f=1.0\text{MHz}$		8.0	pF
t_{on}	$V_{CC}=10\text{V}$, $I_C=300\text{mA}$, $I_{B1}=30\text{mA}$		18	ns
t_{off}	$V_{CC}=10\text{V}$, $I_C=300\text{mA}$, $I_{B1}=I_{B2}=30\text{mA}$		28	ns
t_s	$V_{CC}=10\text{V}$, $I_C=I_{B1}=I_{B2}=10\text{mA}$		18	ns

SOT-23 CASE - MECHANICAL OUTLINE

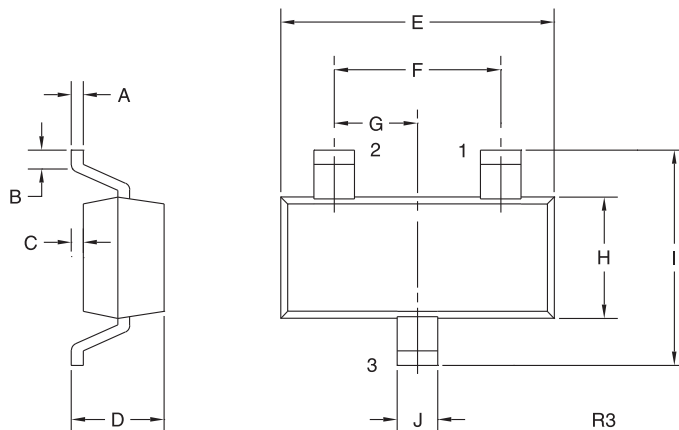

LEAD CODE:

- 1) Base
- 2) Emitter
- 3) Collector

MARKING CODE: C2R

SYMBOL	DIMENSIONS			
	INCHES		MILLIMETERS	
	MIN	MAX	MIN	MAX
A	0.003	0.007	0.08	0.18
B	0.006	-	0.15	-
C	-	0.005	-	0.13
D	0.035	0.043	0.89	1.09
E	0.110	0.120	2.80	3.05
F	0.075		1.90	
G	0.037		0.95	
H	0.047	0.055	1.19	1.40
I	0.083	0.098	2.10	2.49
J	0.014	0.020	0.35	0.50

SOT-23 (REV: R3)

R3 (1-February 2010)

OUTSTANDING SUPPORT AND SUPERIOR SERVICES



PRODUCT SUPPORT

Central's operations team provides the highest level of support to insure product is delivered on-time.

- Supply management (Customer portals)
- Inventory bonding
- Consolidated shipping options
- Custom bar coding for shipments
- Custom product packing

DESIGNER SUPPORT/SERVICES

Central's applications engineering team is ready to discuss your design challenges. Just ask.

- Free quick ship samples (2nd day air)
- Online technical data and parametric search
- SPICE models
- Custom electrical curves
- Environmental regulation compliance
- Customer specific screening
- Up-screening capabilities
- Special wafer diffusions
- PbSn plating options
- Package details
- Application notes
- Application and design sample kits
- Custom product and package development

REQUESTING PRODUCT PLATING

1. If requesting Tin/Lead plated devices, add the suffix "TIN/LEAD" to the part number when ordering (example: 2N2222A TIN/LEAD).
2. If requesting Lead (Pb) Free plated devices, add the suffix "PBFREE" to the part number when ordering (example: 2N2222A PBFREE).

CONTACT US

Corporate Headquarters & Customer Support Team

Central Semiconductor Corp.
145 Adams Avenue
Hauppauge, NY 11788 USA
Main Tel: (631) 435-1110
Main Fax: (631) 435-1824
Support Team Fax: (631) 435-3388
www.centrasemi.com

Worldwide Field Representatives:
www.centrasemi.com/wwreps

Worldwide Distributors:
www.centrasemi.com/wwdistributors

For the latest version of Central Semiconductor's **LIMITATIONS AND DAMAGES DISCLAIMER**, which is part of Central's Standard Terms and Conditions of sale, visit: www.centrasemi.com/terms