



Chipsmall Limited consists of a professional team with an average of over 10 year of expertise in the distribution of electronic components. Based in Hongkong, we have already established firm and mutual-benefit business relationships with customers from,Europe,America and south Asia,supplying obsolete and hard-to-find components to meet their specific needs.

With the principle of “Quality Parts,Customers Priority,Honest Operation,and Considerate Service”,our business mainly focus on the distribution of electronic components. Line cards we deal with include Microchip,ALPS,ROHM,Xilinx,Pulse,ON,Everlight and Freescale. Main products comprise IC,Modules,Potentiometer,IC Socket,Relay,Connector.Our parts cover such applications as commercial,industrial, and automotives areas.

We are looking forward to setting up business relationship with you and hope to provide you with the best service and solution. Let us make a better world for our industry!



Contact us

Tel: +86-755-8981 8866 Fax: +86-755-8427 6832

Email & Skype: info@chipsmall.com Web: www.chipsmall.com

Address: A1208, Overseas Decoration Building, #122 Zhenhua RD., Futian, Shenzhen, China



MODEL: CMR-15062S-67 | **DESCRIPTION:** SPEAKER

FEATURES

- IP67 rated face
- protection against dust and water ingress
- dynamic receiver
- small footprint
- spring contacts



SPECIFICATIONS

parameter	conditions/description	min	typ	max	units
input power			20	30	mW
impedance	at 1.0 kHz, 0.8 Vrms in free air	27.2	32	36.8	Ω
coil resistance		23.8	28	32.2	Ω
resonant frequency (Fo)	at 0.8 Vrms in free air	440	550	660	Hz
frequency response		300		7,000	Hz
sound pressure level	at 1 kHz with Type 3.2 HL Ear, 0.8 Vrms	114	117	120	dB
distortion	see THD curve				%
buzz, rattle, etc.	must be normal at sine wave, 0.3~7 kHz		0.8		Vrms
polarity	cone moves forward w/ positive dc current to "+" terminal				
dimensions	15 x 6 x 2				mm
magnet	Nd-Fe-B				
cone material	mylar				
weight			0.4		g
operating temperature		-20		70	$^{\circ}\text{C}$
storage temperature		-40		85	$^{\circ}\text{C}$
RoHS	yes				
IP level	IP67 (front side)				

Notes: 1. All specifications measured at 15~35 $^{\circ}\text{C}$, humidity at 25~75%, under 86~106 kPa pressure, unless otherwise noted.

MECHANICAL DRAWING

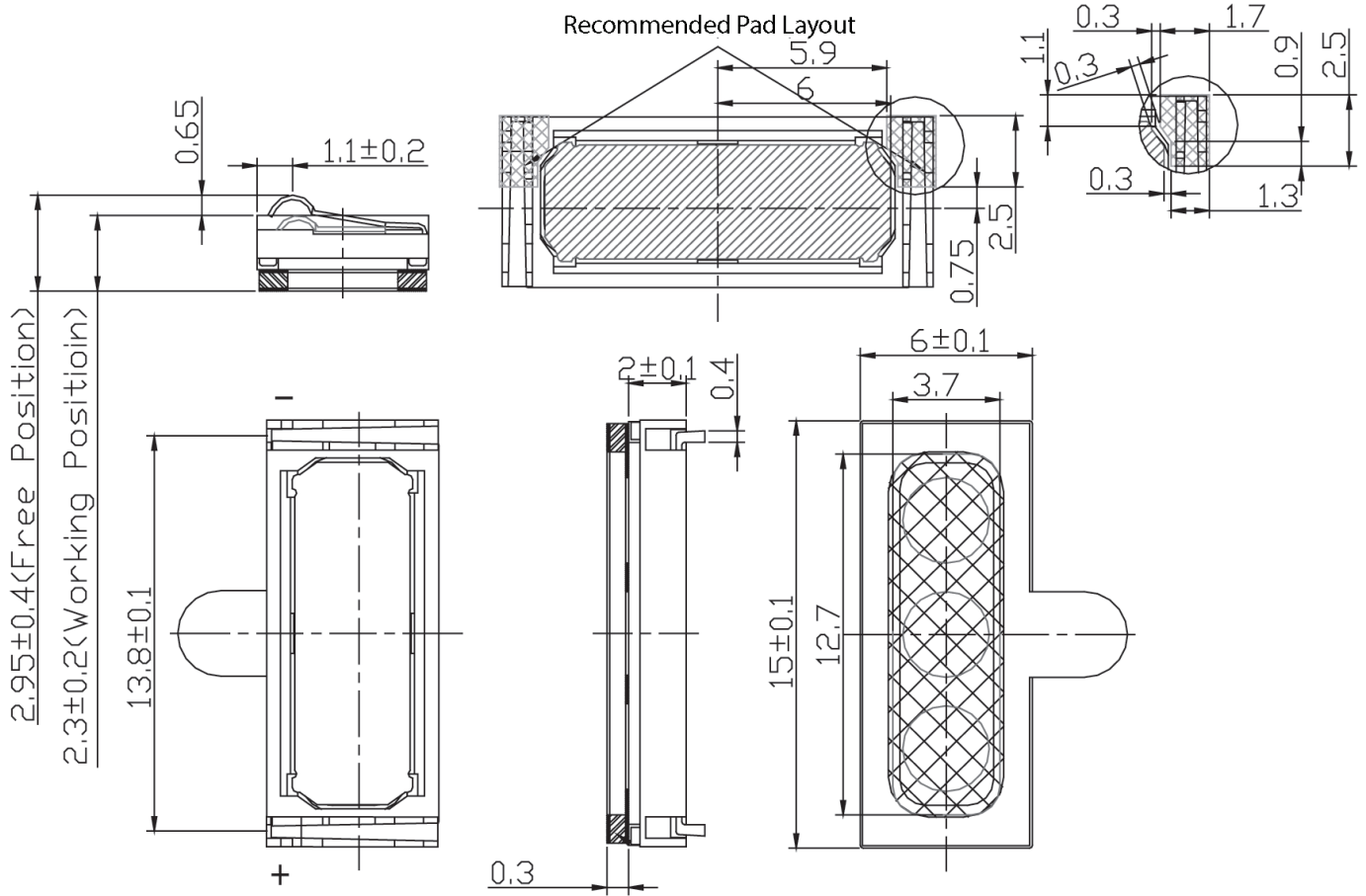
units: mm
tolerance: ± 0.2 mm



MECHANICAL DRAWING (GASKET)

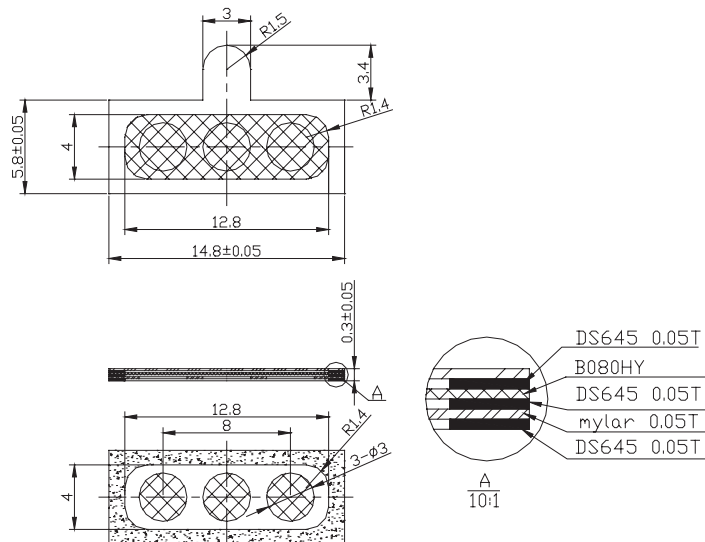

RESPONSE CURVES

Frequency Response Curve

Test Conditions: 0.8 Vrms / Type 3.2 HL Ear

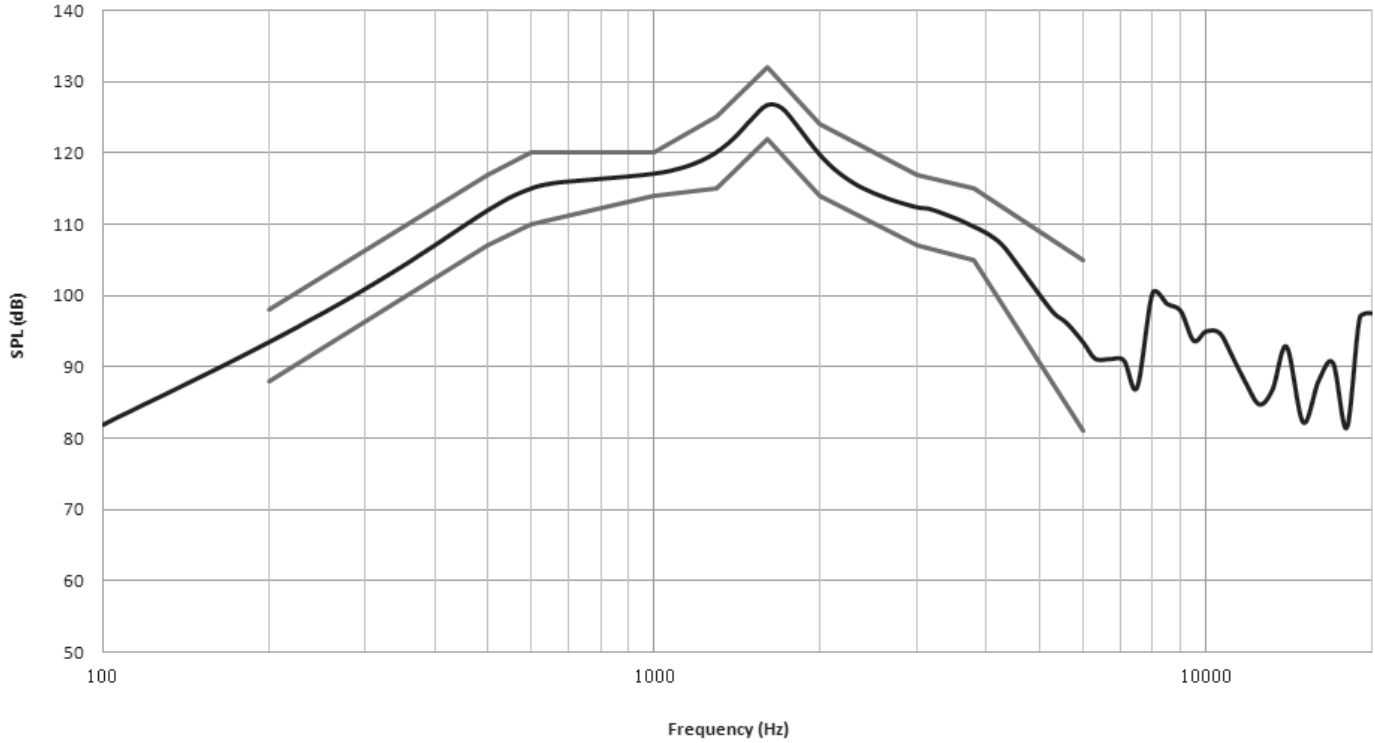

Total Harmonic Distortion Curve

Test Conditions: 0.8 Vrms / Type 3.2 HL Ear

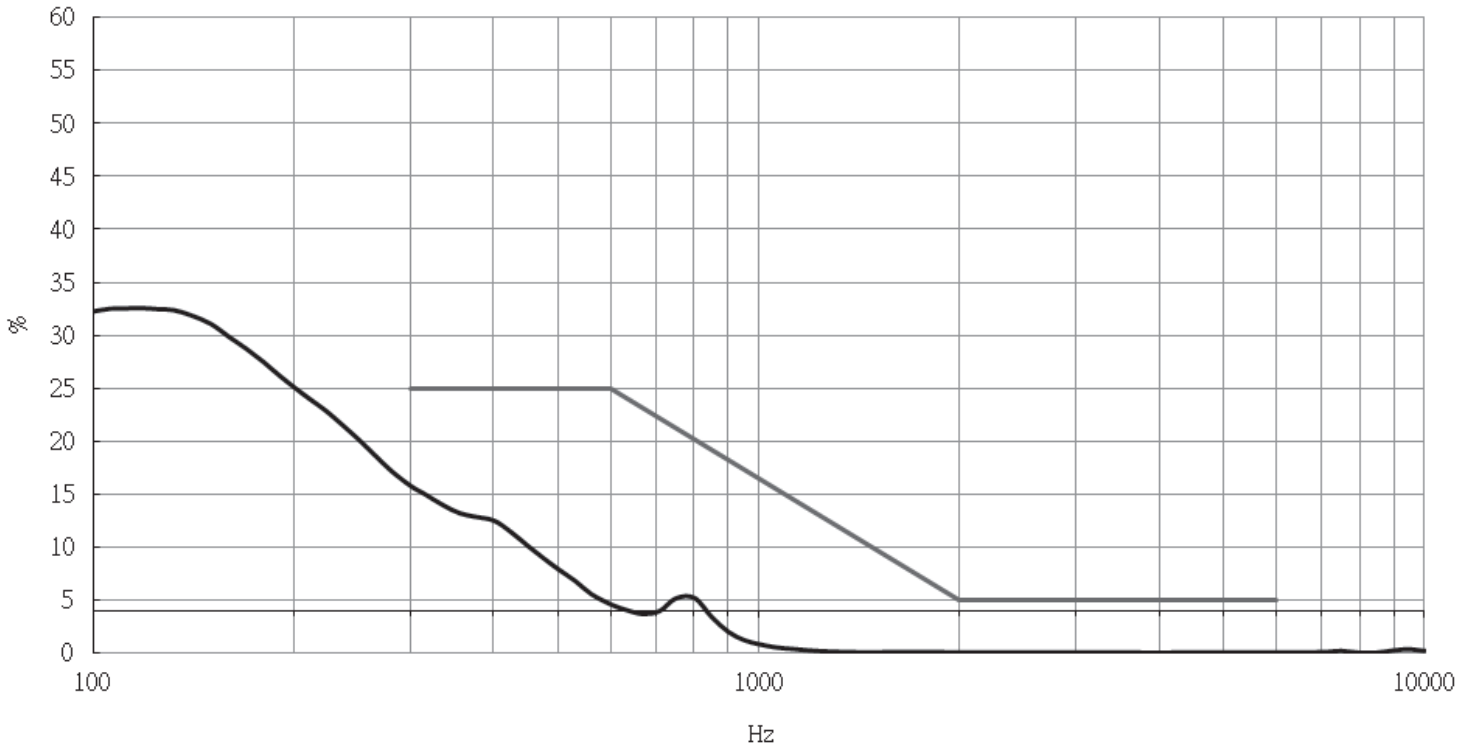

PACKAGING

units: mm

Tray QTY: 200 pcs per tray
Carton Size: 345 x 260 x 390 mm
Carton QTY: 6,800 pcs per carton

200PCSx1=200PCS/tray

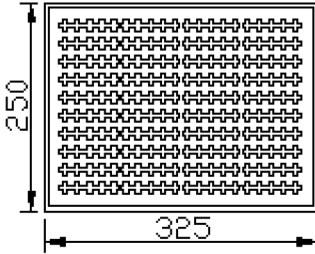

6800PCSx1=6800PCS/box

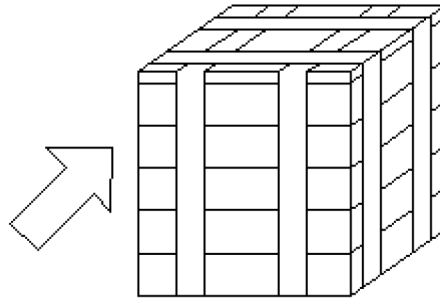

200PCSx34=6800PCS/stack

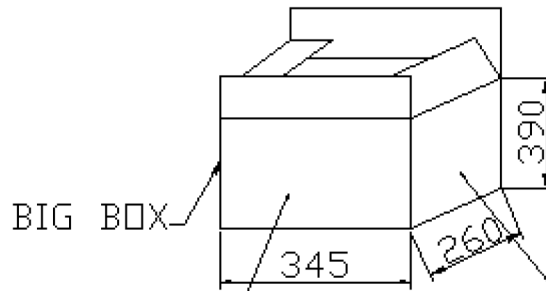
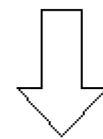
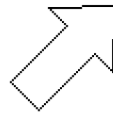
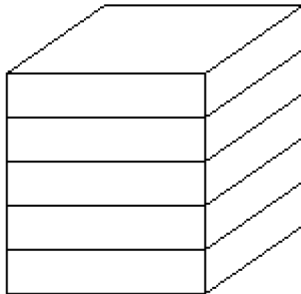

6	#
X	A
MODEL:	
QTY:	PCS
N.W:	Kg
G.W:	kg
SIZE:	34.5X26X39 cm
LOT NO	

REVISION HISTORY

rev.	description	date
1.0	initial release	07/24/2018

The revision history provided is for informational purposes only and is believed to be accurate.



CUI INC[®]

Headquarters
20050 SW 112th Ave.
Tualatin, OR 97062
800.275.4899

Fax 503.612.2383
cui.com
techsupport@cui.com

CUI offers a one (1) year limited warranty. Complete warranty information is listed on our website.

CUI reserves the right to make changes to the product at any time without notice. Information provided by CUI is believed to be accurate and reliable. However, no responsibility is assumed by CUI for its use, nor for any infringements of patents or other rights of third parties which may result from its use.

CUI products are not authorized or warranted for use as critical components in equipment that requires an extremely high level of reliability. A critical component is any component of a life support device or system whose failure to perform can be reasonably expected to cause the failure of the life support device or system, or to affect its safety or effectiveness.