



Chipsmall Limited consists of a professional team with an average of over 10 year of expertise in the distribution of electronic components. Based in Hongkong, we have already established firm and mutual-benefit business relationships with customers from,Europe,America and south Asia,supplying obsolete and hard-to-find components to meet their specific needs.

With the principle of “Quality Parts,Customers Priority,Honest Operation,and Considerate Service”,our business mainly focus on the distribution of electronic components. Line cards we deal with include Microchip,ALPS,ROHM,Xilinx,Pulse,ON,Everlight and Freescale. Main products comprise IC,Modules,Potentiometer,IC Socket,Relay,Connector.Our parts cover such applications as commercial,industrial, and automotives areas.

We are looking forward to setting up business relationship with you and hope to provide you with the best service and solution. Let us make a better world for our industry!



## Contact us

Tel: +86-755-8981 8866 Fax: +86-755-8427 6832

Email & Skype: info@chipsmall.com Web: www.chipsmall.com

Address: A1208, Overseas Decoration Building, #122 Zhenhua RD., Futian, Shenzhen, China





**PART NUMBER:** CMR-5054TB-A

**DESCRIPTION:** electret condenser microphone

**SPECIFICATIONS**

directivity	noise-canceling	
sensitivity (S)	-54 ±3 dB	f = 1KHz, 1Pa 0dB = 1V/Pa
sensitivity reduction (ΔS-Vs)	-3 dB	f = 1KHz, 1Pa Vs = 2 ~ 1.5 V dc
operating voltage	2 V dc (standard), 10 V dc (max.)	
output impedance (Zout)	2.2 KΩ	f = 1KHz, 1Pa
operating frequency (f)	100 ~ 10,000 Hz	
current consumption (IDSS)	0.5 mA max.	Vs = 2 V dc RL = 2.2KΩ
signal to noise ratio (S/N)	56 dBA	f = 1KHz, 1Pa A-weighted
operating temperature	-20 ~ +70° C	
storage temperature	-20 ~ +70° C	
dimensions	ø6.0 x 5.0 mm	
weight	0.30 g max.	
material	Al	
terminal	terminal type (hand soldering only)	
RoHS	yes	

note: We use the "Pascal (Pa)" indication of sensitivity as per the recommendation of I.E.C. (International Electrotechnical Commission). The sensitivity of "Pa" will increase 20dB compared to the "ubar" indication. Example: -60dB (0dB = 1V/ubar) = -40dB (1V/Pa)

**APPEARANCE DRAWING**

tolerances not shown: ±0.3mm

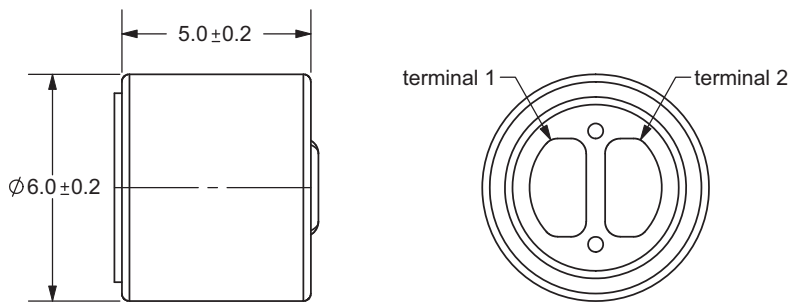

**PART NUMBER:** CMR-5054TB-A

**DESCRIPTION:** electret condenser microphone

### MEASUREMENT CIRCUIT

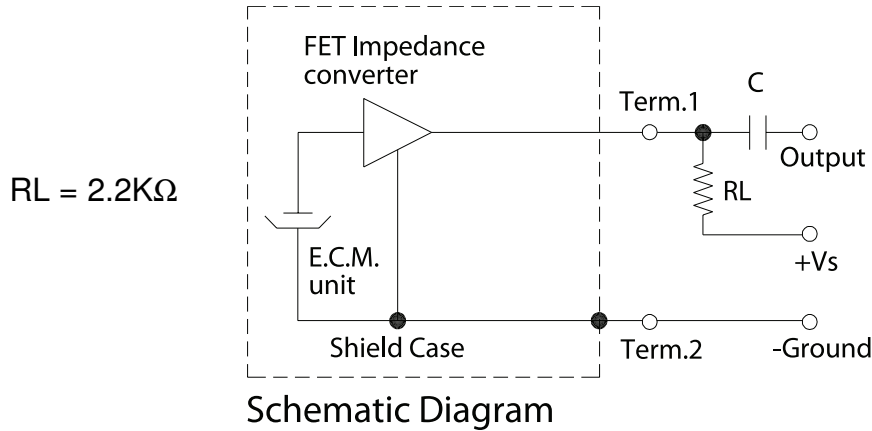

### FREQUENCY RESPONSE CURVE

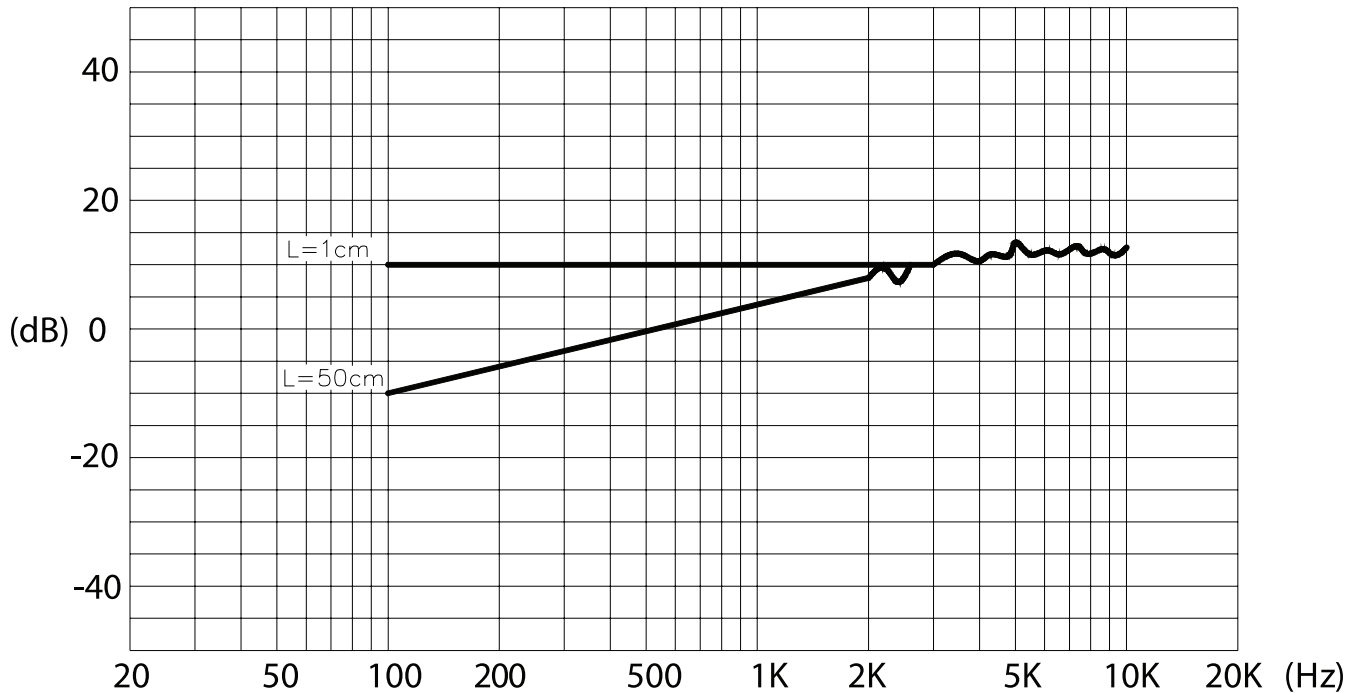



**PART NUMBER:** CMR-5054TB-A

**DESCRIPTION:** electret condenser microphone

**MECHANICAL CHARACTERISTICS**

item	test condition	evaluation standard
soldering heat resistance	Soldering iron of 270 ±5°C should be placed on the terminal for 2 ±0.5 seconds.	No interference in operation.
PCB wire pull strength	The pull force will be applied to double lead wire: Horizontal 4.9N (0.5kg) for 30 seconds	No damage or cutting off.
vibration	The part will be measured after applying a vibration amplitude of 1.5 mm with 10 to 55 Hz band of vibration frequency to each of the 3 perpendicular directions for 2 hours.	After any tests, the sensitivity should be within ±3dB compared to the initial measurement.
drop test	The part will be dropped from a height of 1 m onto a 20 mm thick wooden board 3 times in 3 axes (X, Y, Z) for a total of 9 drops.	

**ENVIRONMENT TEST**

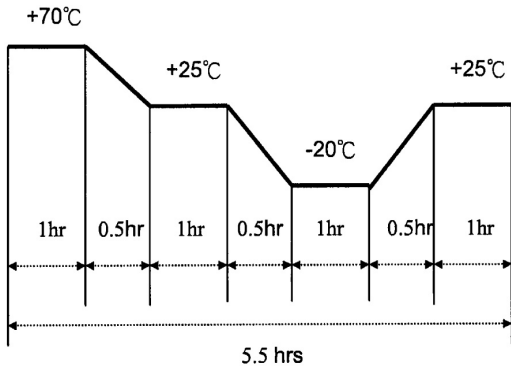
item	test condition	evaluation standard
high temp. test	After being placed in a chamber at +70°C for 72 hours.	The part will be measured after being placed at +25°C for 6 hours. After any tests, the sensitivity should be within ±3dB compared to the initial measurement.
low temp. test	After being placed in a chamber at -20°C for 72 hours.	
humidity test	After being placed in a chamber at +40°C and 90±5% relative humidity for 240 hours.	
temp. cycle test	The part shall be subjected to 10 cycles. One cycle will consist of: 	

**TEST CONDITIONS**

standard test condition	a) temperature: +5 ~ +35°C	b) humidity: 45 - 85%	c) pressure: 860-1060 mbar
judgement test condition	a) temperature: +25 ±2°C	b) humidity: 60 - 70%	c) pressure: 860-1060 mbar

**PART NUMBER:** CMR-5054TB-A

**DESCRIPTION:** electret condenser microphone

**PACKAGING**

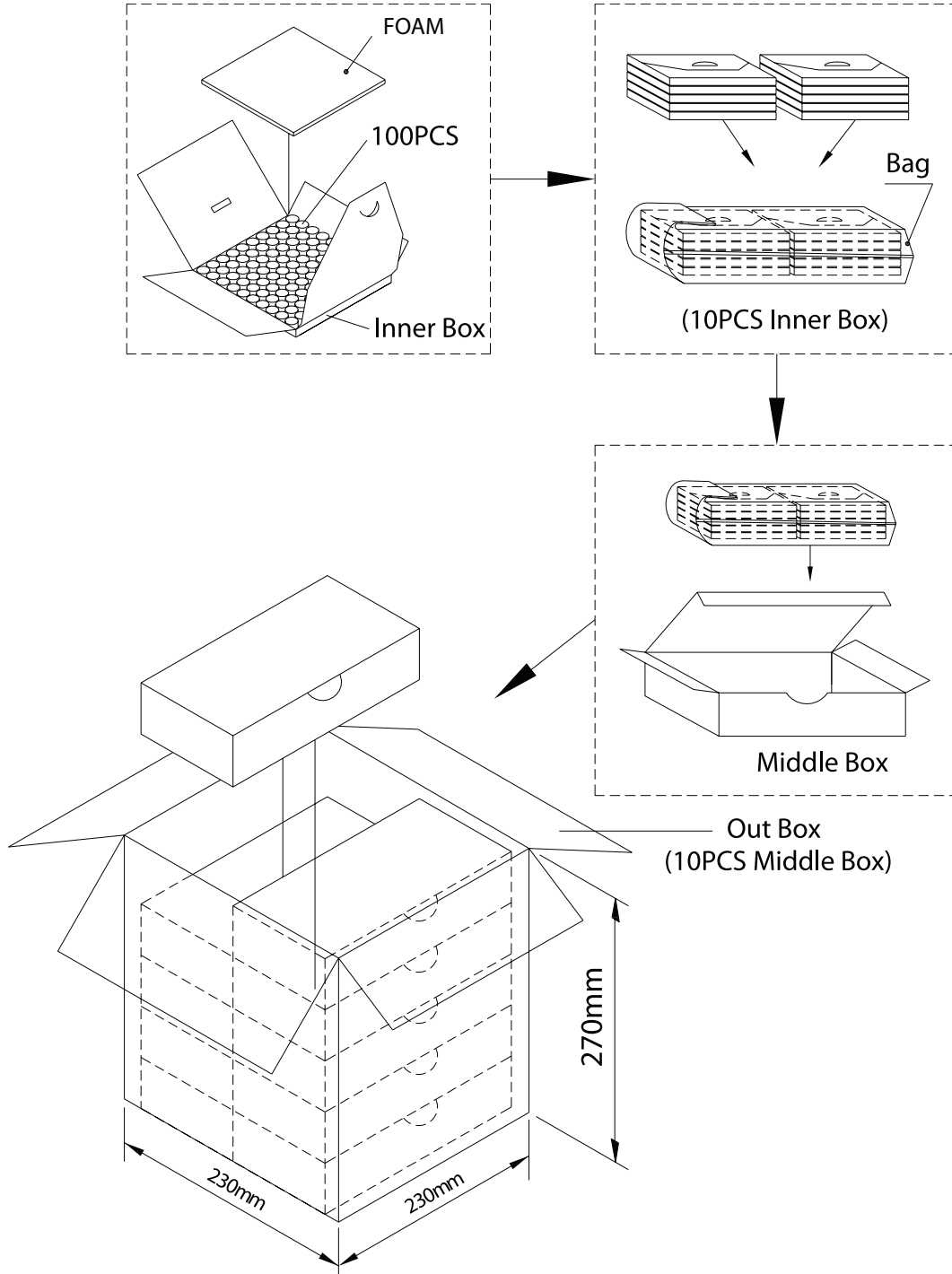

Inner Box	100mmx100mmx8mm	1x100PCS=100PCS
Middle Box	205mmx106mmx52mm	100PCSx10=1,000PCS
Out Box	230mmx230mmx270mm	1,000PCSx10=10,000PCS