



Chipsmall Limited consists of a professional team with an average of over 10 year of expertise in the distribution of electronic components. Based in Hongkong, we have already established firm and mutual-benefit business relationships with customers from,Europe,America and south Asia,supplying obsolete and hard-to-find components to meet their specific needs.

With the principle of “Quality Parts,Customers Priority,Honest Operation,and Considerate Service”,our business mainly focus on the distribution of electronic components. Line cards we deal with include Microchip,ALPS,ROHM,Xilinx,Pulse,ON,Everlight and Freescale. Main products comprise IC,Modules,Potentiometer,IC Socket,Relay,Connector.Our parts cover such applications as commercial,industrial, and automotives areas.

We are looking forward to setting up business relationship with you and hope to provide you with the best service and solution. Let us make a better world for our industry!



## Contact us

Tel: +86-755-8981 8866 Fax: +86-755-8427 6832

Email & Skype: info@chipsmall.com Web: www.chipsmall.com

Address: A1208, Overseas Decoration Building, #122 Zhenhua RD., Futian, Shenzhen, China



Common Mode Coil

A. Electrical Specifications (@25°C)

1. Rated Voltage; 250VAC 50/60Hz
2. Rated Current; 3A AC
3. Common Mode Inductance (@ 1KHz); 2mH MIN
4. DC Resistance; (each winding) 0.10Ω MAX
6. Insulation Resistance; 100MΩ MIN at 500VDC Winding to Winding, Winding to Core
7. HiPot test; AC 2.0KV 1 minute Winding to Winding, Winding to Core

MODEL NUMBER  
**CMT-02302**

B. Schematic Diagram;

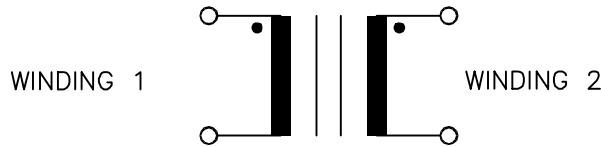

Country of origin

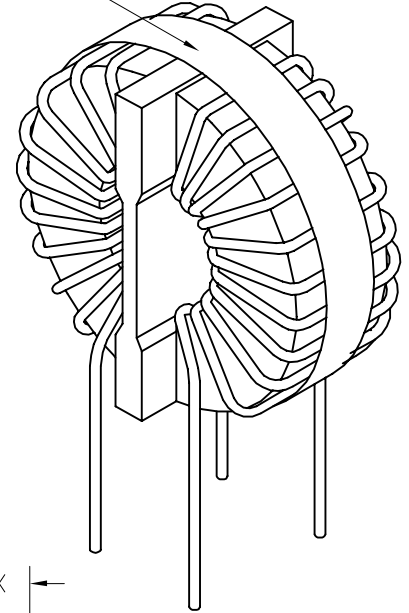

C. Mechanical Specifications;

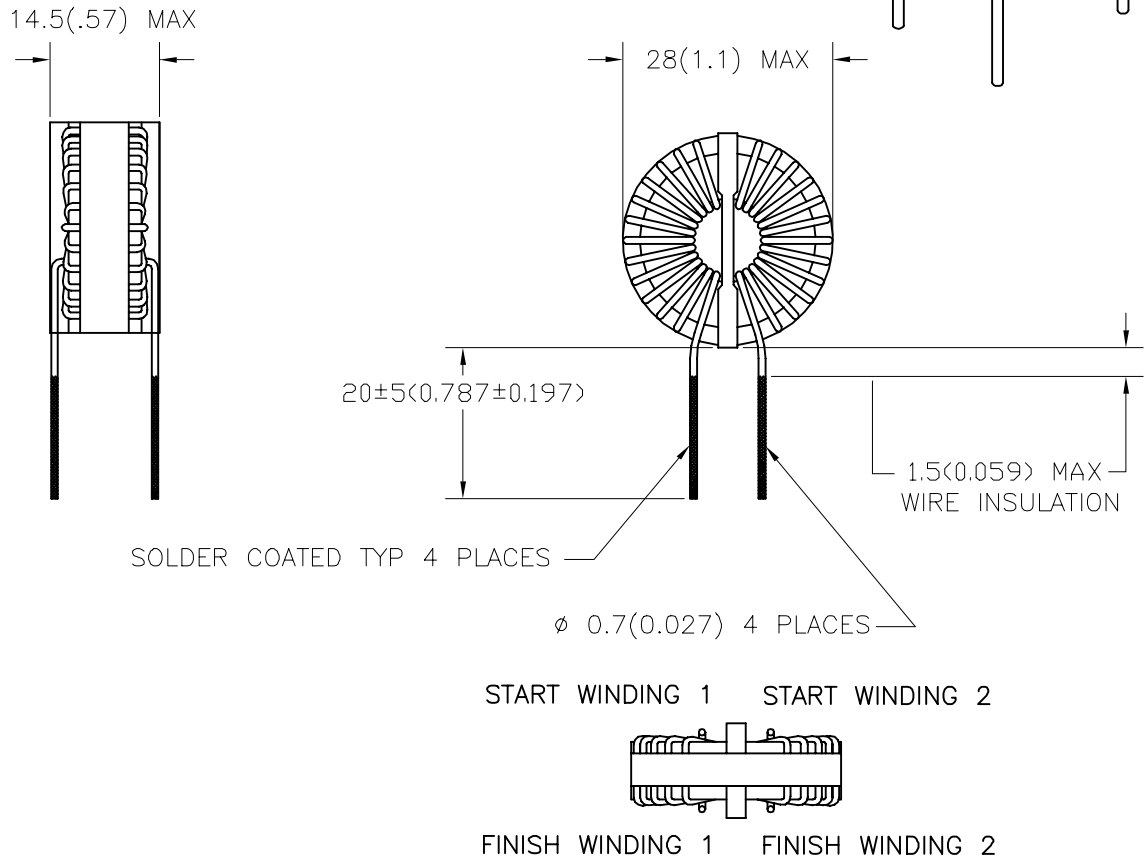

PREPARED BY:

D. Rund

ENGINEER:

T. Shiozawa

QUALITY CONTROL:

D. Kelley

APPROVED:

D. Kelley

DWG CONTROL NO.  
P-A4-12224  
ACAD\MISCX\A4122241.DWG

REV  
-

COIL  
COMMON MODE

**CMT-02302**

MODEL SPECIFICATION

CONTENTS OF THIS DRAWING ARE  
SUBJECT TO CHANGE WITHOUT  
PRIOR NOTICE

**TAMURA CORPORATION OF AMERICA**  
43352 BUSINESS PARK DRIVE, TEMECULA, CA. 92590-6624  
(909) 699-1270 FAX 9096769482

DIM: mm(In) SCL: 1/1 SH: 1 OF 1

PROPRIETARY NOTICE: THIS DRAWING PRINT OR DOCUMENT AND SUBJECT MATTER DISCLOSED HEREIN ARE PROPRIETARY ITEMS TO WHICH TAMURA RETAINS THE EXCLUSIVE RIGHT OF DISSEMINATION, REPRODUCTION, MANUFACTURE AND SALE. THIS DRAWING, PRINT OR DOCUMENT IS SUBMITTED IN CONFIDENCE FOR CONSIDERATION BY THE RECIPIENT ALONE UNLESS PERMISSION FOR FURTHER DISCLOSURE IS EXPRESSLY GRANTED IN WRITING.