



Chipsmall Limited consists of a professional team with an average of over 10 year of expertise in the distribution of electronic components. Based in Hongkong, we have already established firm and mutual-benefit business relationships with customers from,Europe,America and south Asia,supplying obsolete and hard-to-find components to meet their specific needs.

With the principle of "Quality Parts,Customers Priority,Honest Operation,and Considerate Service",our business mainly focus on the distribution of electronic components. Line cards we deal with include Microchip,ALPS,ROHM,Xilinx,Pulse,ON,Everlight and Freescale. Main products comprise IC,Modules,Potentiometer,IC Socket,Relay,Connector.Our parts cover such applications as commercial,industrial, and automotives areas.

We are looking forward to setting up business relationship with you and hope to provide you with the best service and solution. Let us make a better world for our industry!



## Contact us

Tel: +86-755-8981 8866 Fax: +86-755-8427 6832

Email & Skype: info@chipsmall.com Web: www.chipsmall.com

Address: A1208, Overseas Decoration Building, #122 Zhenhua RD., Futian, Shenzhen, China



**NOTES:**

unless otherwise specified

1.Specifications:

Impedance: 50 OHMS  
 Working Voltage: 500 VRMS @ Sea Level  
 Frequency Range: 0-7 GHz  
 Interface per MIL-STD-348, Section 304.1 & 313.2

ALL DIMENSIONS ARE FOR REFERENCE ONLY

ITEM	DESCRIPTION	QTY	MATERIAL	FINISH
1	BODY	1	BRASS	NICKEL
2	CONTACT	1	BRASS	GOLD
3	DIELECTRIC	1	TEFLON	NONE
4	DIELECTRIC	1	TEFLON	NONE
5	GROUND RING	1	BRASS	NICKEL
6	GASKET	1	S.I. RUBBER	RED
7	RETAINING RING	1	BRASS	NONE
8	SHELL	1	BRASS	NICKEL

REVISIONS					
ZONE	REV.	DESCRIPTION	DATE	DRAWN BY	ECR NUMBER
ALL	A	INITIAL DRAWING RELEASE	8/22/2012	PFR	N/A

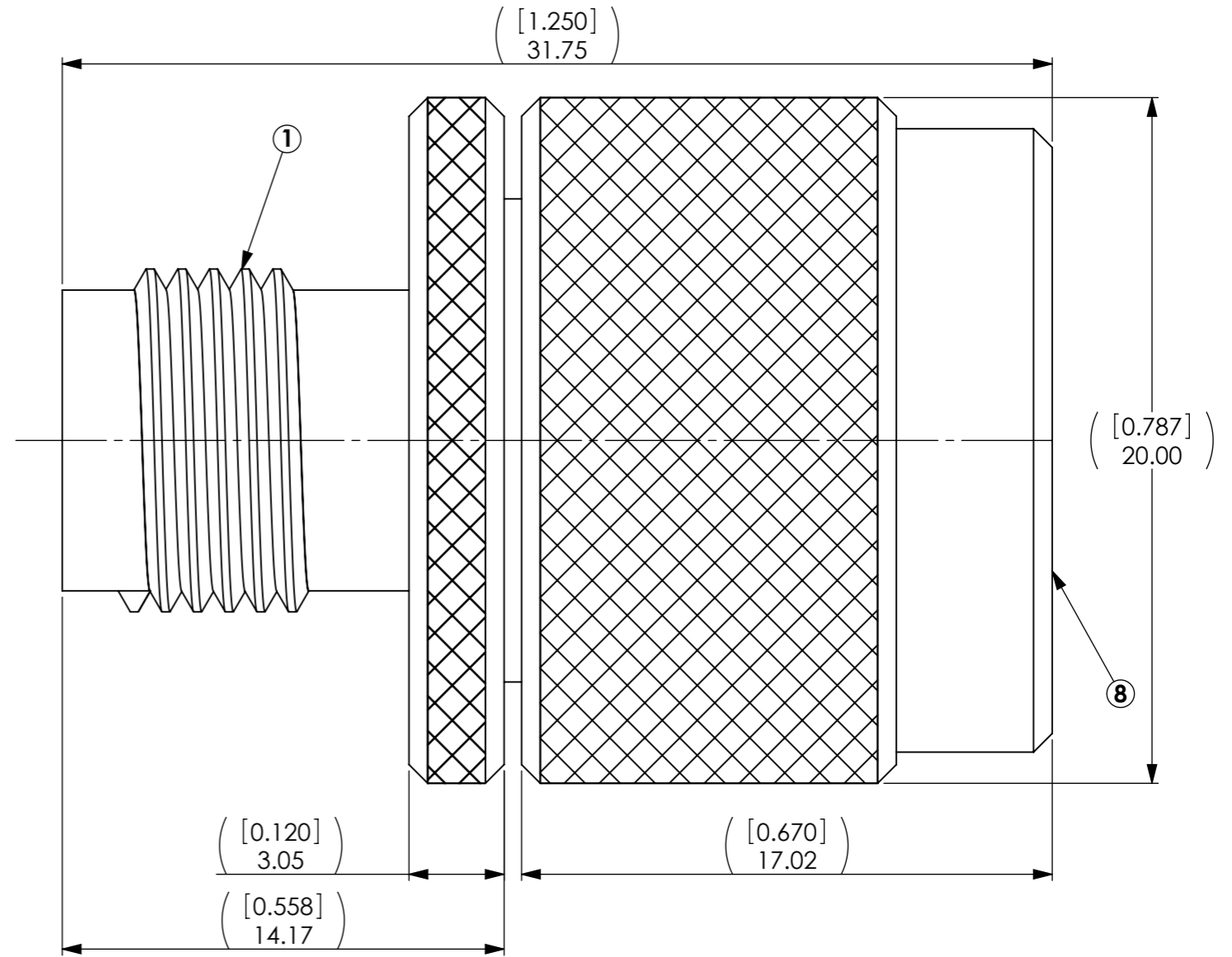

**Notes:**  
 THE COMPONENT(S), INCLUDING ANY PLATING, FINISHES, COATINGS, CHEMICALS AND SURFACES TREATMENTS, SUPPLIED IN THIS DOCUMENT/DRAWING MUST CONFORM AND COMPLY WITH THE LATEST ISSUE OF LAIRD TECHNOLOGIES SPECIFICATION LT-GES-001, WHICH FULLY INCLUDES BUT IS NOT LIMITED TO ALL CONTENTS OF EU DIRECTIVES 2002/96/EC (RoHS DIRECTIVE), AS WELL AS INCLUDES REQUIREMENTS OF THE JOINT INDUSTRY GUIDE STANDARD JIG-101, APRIL 2005. THE COMPONENT(S) IN THIS DOCUMENT/DRAWING MAY BE SUBJECT TO A FULL COMPOUND ANALYSIS FOR PROOF OF COMPLIANCE. THE LATEST ISSUE OF LAIRD TECHNOLOGIES SPECIFICATION LT-GES-001, (GENERAL SPECIFICATION FOR THE ENVIRONMENT) IS READILY AVAILABLE UPON REQUEST FROM THE SUPPLIER.

UNLESS OTHERWISE NOTED, THIS DOCUMENT CONTAINS LAIRD TECHNOLOGIES CONFIDENTIAL INFORMATION. REPRODUCTION, USE, DISCLOSURE OR TRANSMITTAL OF ALL OR ANY PART OF THIS DOCUMENT IS PROHIBITED EXCEPT TO THE EXTENT APPROVED IN WRITING BY AN AUTHORIZED REPRESENTATIVE OF LAIRD TECHNOLOGIES. LAIRD TECHNOLOGIES RESERVES ALL RIGHTS UNDER PATENTS, TRADEMARKS, COPY RIGHTS AND TRADE SECRETS. COPYRIGHT, LAIRD TECHNOLOGIES 2008, ALL RIGHTS RESERVED.

<b>MATERIAL:</b> SEE TABLE		THIRD ANGLE PROJECTION
<b>FINISH:</b> SEE TABLE		
<b>APPROVALS</b>	<b>DATE</b>	INTERPRET DIMENSIONING AND TOLERANCING IN ACCORDANCE WITH ASME Y14.5M-1994
<b>ME:</b>		<b>DO NOT SCALE DRAWING</b>
<b>RF:</b>		TOLERANCES UNLESS OTHERWISE SPECIFIED
<b>EM:</b>		DIMENSIONS ARE IN MILLIMETERS
<b>Prod:</b>		ANGLE: ±30'
		0 PLACE DECIMAL: ±0.5
		1 PLACE DECIMAL: ±0.25
		2 PLACE DECIMAL: ±0.13

**Laird TECHNOLOGIES** 1751 WILKENING COURT  
 SCHAUMBURG, IL 60173  
 USA

**TITLE:** TNC FEMALE TO N MALE

<b>SIZE</b> A3	<b>DWG NO.</b> CNTNCF	<b>REV</b> A
----------------	-----------------------	--------------