



Chipsmall Limited consists of a professional team with an average of over 10 year of expertise in the distribution of electronic components. Based in Hongkong, we have already established firm and mutual-benefit business relationships with customers from,Europe,America and south Asia,supplying obsolete and hard-to-find components to meet their specific needs.

With the principle of “Quality Parts,Customers Priority,Honest Operation,and Considerate Service”,our business mainly focus on the distribution of electronic components. Line cards we deal with include Microchip,ALPS,ROHM,Xilinx,Pulse,ON,Everlight and Freescale. Main products comprise IC,Modules,Potentiometer,IC Socket,Relay,Connector.Our parts cover such applications as commercial,industrial, and automotives areas.

We are looking forward to setting up business relationship with you and hope to provide you with the best service and solution. Let us make a better world for our industry!



## Contact us

Tel: +86-755-8981 8866 Fax: +86-755-8427 6832

Email & Skype: info@chipsmall.com Web: www.chipsmall.com

Address: A1208, Overseas Decoration Building, #122 Zhenhua RD., Futian, Shenzhen, China





# 22mm TuffLED™ Panel Mount Indicator



Ruggedized CNX 722 Series with built-in LED offers fast, easy installation in harsh environments

## Applications

- control cabinets
- instrument panels
- disinfection and sterilization environments
- transportation dashboards
- switch stations
- safety applications
- outdoor signage
- aircraft and military
- industrial machinery
- vending and gaming machines

## Key features

- designed for extreme harsh and outdoor environments
- variety of connection options for fast, easy installation
- built-in LED can be used with 5, 12 or 24 volt D/C circuits
- fast pitch threads ease assembly, requiring only 1 turn
- special nut assembles by finger, or with 1" hextool
- direct sunlight visibility
- wide angle viewable
- resistant to shock and vibration
- custom LEDs and lens colors available
- optional bezel available in many colors
- moisture sealed, IP 67/NEMA 6P rated
- RoHS compliant

## Product dimensions

Indicator Assemblies

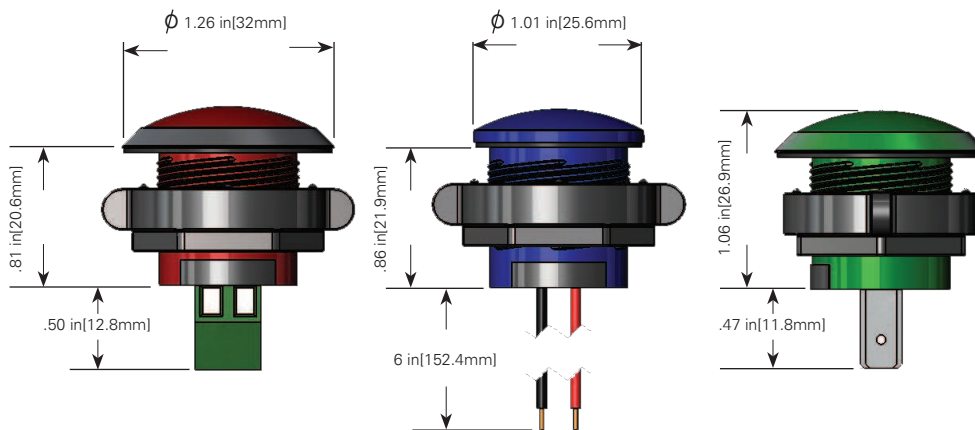

Bezels

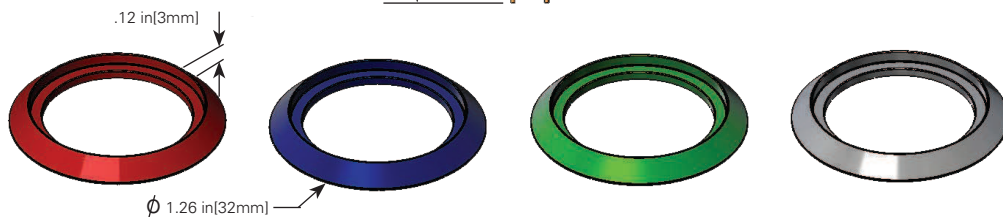

## Product specifications

LED output	
LED color**	typ intensity, mcd
red	1300-1900
green	700-1400
white	1300-1700
blue	200-280
yellow	80-200

Materials	
body	polycarbonate, UL 94-V2
retaining nut	PBT/glass filled, UL 94-V0
wire	22 AWG 1007/1569
moisture seal	EPDM
bezel- plastic	ABS, UL 94-HB
bezel- metal	aluminum alloy

Installation specification	
mounting hole	.855-.910" (21.7-23.1mm)
panel thickness	Up to .300" (7.6mm)

Operating parameters	
operating temperature	-40°F (-40°C) to 176°F (80°C)
current	20mA

## Ordering data

CNX 722 22mm indicator  
ordering code (example)

CNX 722 X X00 XX X

Body Type	
X=	material
C	colored*
N	clear

LED Color	
X00=	color
200	red
400	yellow
500	green
600	blue
900	white

Voltage	
XX=	input voltage
05	5VDC
12	12VDC
24	24VDC

Termination Style	
X=	termination style
B	screw block
T	quick disconnect/ terminals
W	wire leads

\*Body color to match  
LED color

**\*Optional bezel: BZL 722-X**

Bezel size = 22mm

\*Sold Separately

Bezel Color	
X=	color
0	black
2	red
4	yellow
5	green
6	blue
9	white
A	actual aluminum
B	brushed aluminum
C	chrome