



Chipsmall Limited consists of a professional team with an average of over 10 year of expertise in the distribution of electronic components. Based in Hongkong, we have already established firm and mutual-benefit business relationships with customers from,Europe,America and south Asia,supplying obsolete and hard-to-find components to meet their specific needs.

With the principle of “Quality Parts,Customers Priority,Honest Operation,and Considerate Service”,our business mainly focus on the distribution of electronic components. Line cards we deal with include Microchip,ALPS,ROHM,Xilinx,Pulse,ON,Everlight and Freescale. Main products comprise IC,Modules,Potentiometer,IC Socket,Relay,Connector.Our parts cover such applications as commercial,industrial, and automotives areas.

We are looking forward to setting up business relationship with you and hope to provide you with the best service and solution. Let us make a better world for our industry!



Contact us

Tel: +86-755-8981 8866 Fax: +86-755-8427 6832

Email & Skype: info@chipsmall.com Web: www.chipsmall.com

Address: A1208, Overseas Decoration Building, #122 Zhenhua RD., Futian, Shenzhen, China





4

3

2

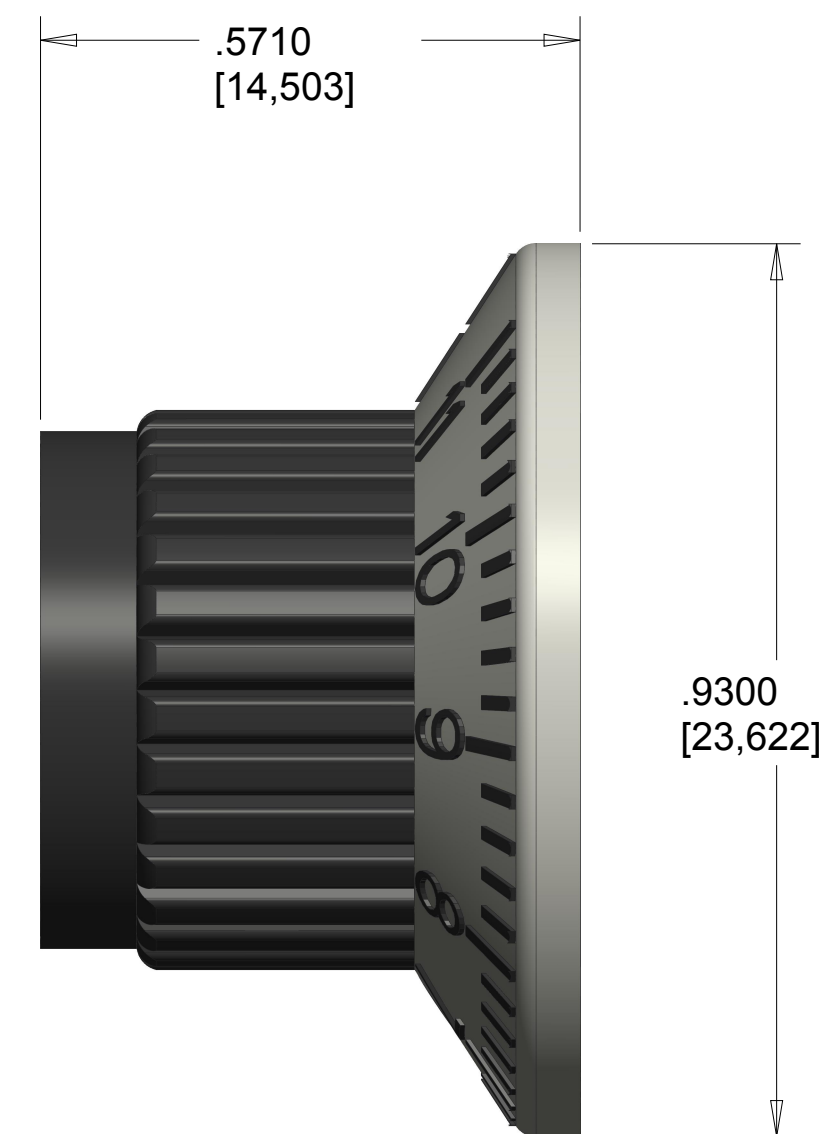
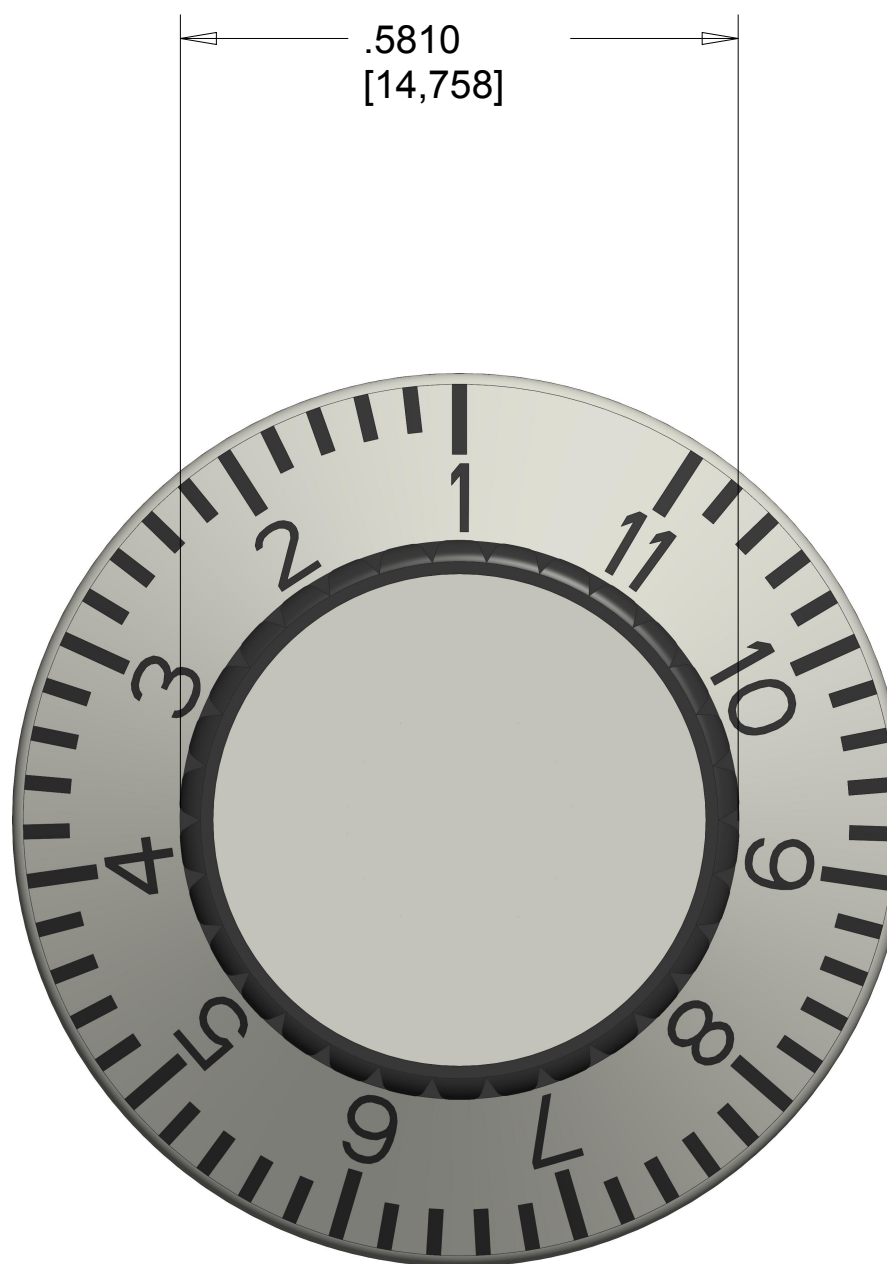
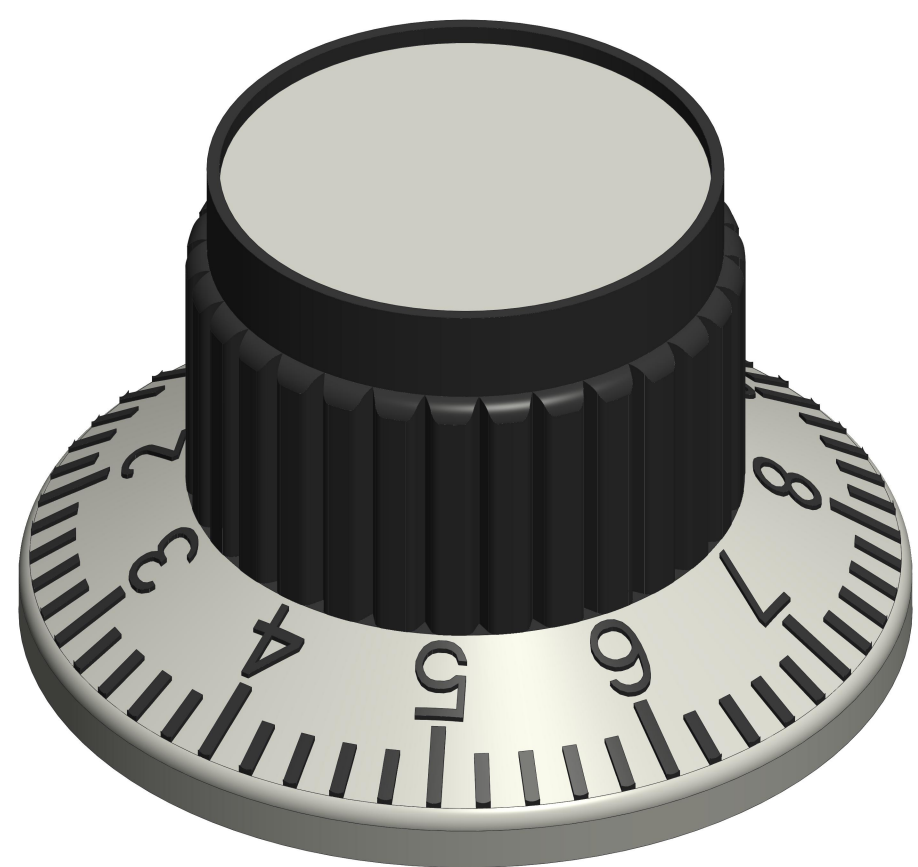
1



Available in small, medium, and large size. Mounts on 6mm shaft.	MATERIAL:	Metal + Plastic		MODEL NAME:	COM-11951	
	NOTES:	Do you need that extra push over the cliff? The Small sized GTE (Goes To Eleven) Knob can fit onto potentiometers with a 6mm wide shaft thanks to a brass insert with a set screw. We know that most of you are playing at ten, but with the GTE Knob you can go... one louder.		https://www.sparkfun.com/products/11951		
	DESCRIPTION:			GTE Knob Small		
	DRAWN BY:	Paul Smith		SCALE:	5.0	
	DATE:	15 August 2013		UNITS:	inch[mm]	
	CAD APPLICATION:	Creo Parametric 2.0		VER:	1.0	SHEET 1 / 1

4

3

2

1