



Chipsmall Limited consists of a professional team with an average of over 10 year of expertise in the distribution of electronic components. Based in Hongkong, we have already established firm and mutual-benefit business relationships with customers from,Europe,America and south Asia,supplying obsolete and hard-to-find components to meet their specific needs.

With the principle of "Quality Parts,Customers Priority,Honest Operation,and Considerate Service",our business mainly focus on the distribution of electronic components. Line cards we deal with include Microchip,ALPS,ROHM,Xilinx,Pulse,ON,Everlight and Freescale. Main products comprise IC,Modules,Potentiometer,IC Socket,Relay,Connector.Our parts cover such applications as commercial,industrial, and automotives areas.

We are looking forward to setting up business relationship with you and hope to provide you with the best service and solution. Let us make a better world for our industry!



Contact us

Tel: +86-755-8981 8866 Fax: +86-755-8427 6832

Email & Skype: info@chipsmall.com Web: www.chipsmall.com

Address: A1208, Overseas Decoration Building, #122 Zhenhua RD., Futian, Shenzhen, China



| DESCRIPTION | MATERIAL | FINISH |
|-------------|----------|--------|
| BODY | BRASS | NICKEL |
| PIN | BeCu | GOLD |
| INSULATION | PTFE | N/A |

| REVISIONS | | | |
|-----------|---|-----------|------|
| REV | DESCRIPTION | DATE | APPV |
| B | ADDED NEW TITLE BLOCK; UPDATED FOOTPRINT | 25-APR-12 | SAH |
| C | UPDATED MATERIALS; UPDATED THREADS FROM 2B TO 2A | 10-JUL-12 | SAH |
| D | ADDED PIN TO PCB DIMENSION | 17-OCT-12 | SAH |
| E | ADDED CONTACT TO STANDOFF DIMENSION; UPDATED NOTE 3; UPDATED VARIOUS DIMENSIONS | 3-MAY-16 | SAH |

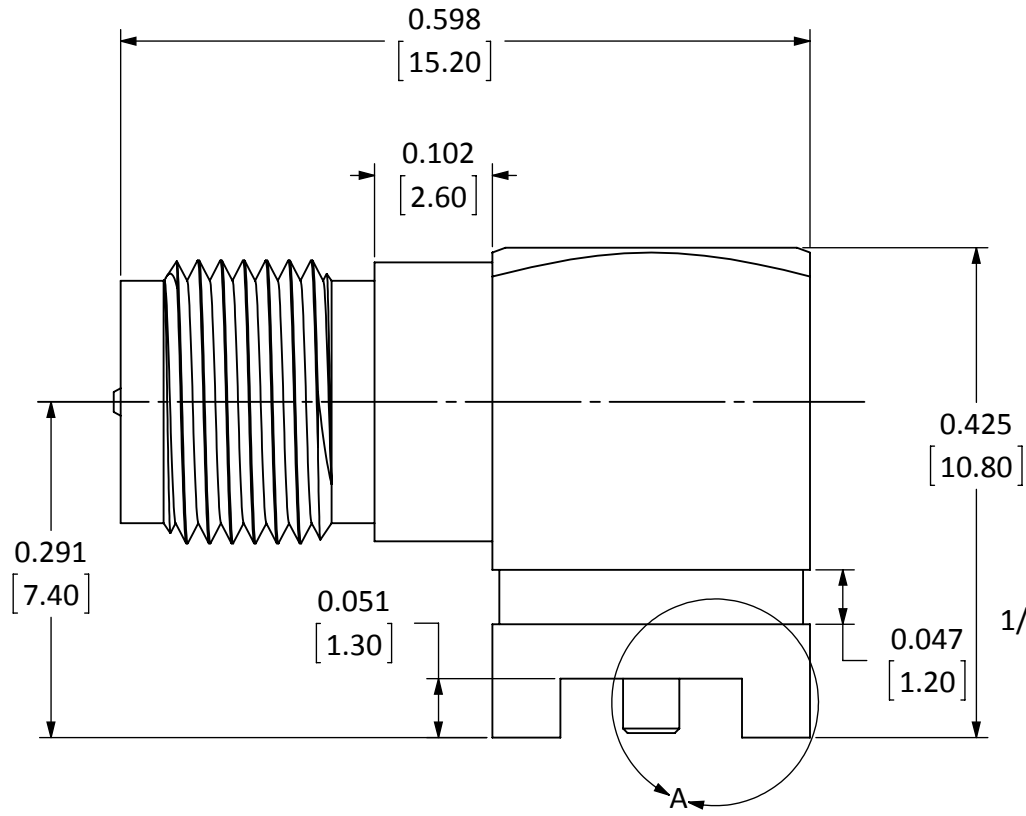

SIDE VIEW

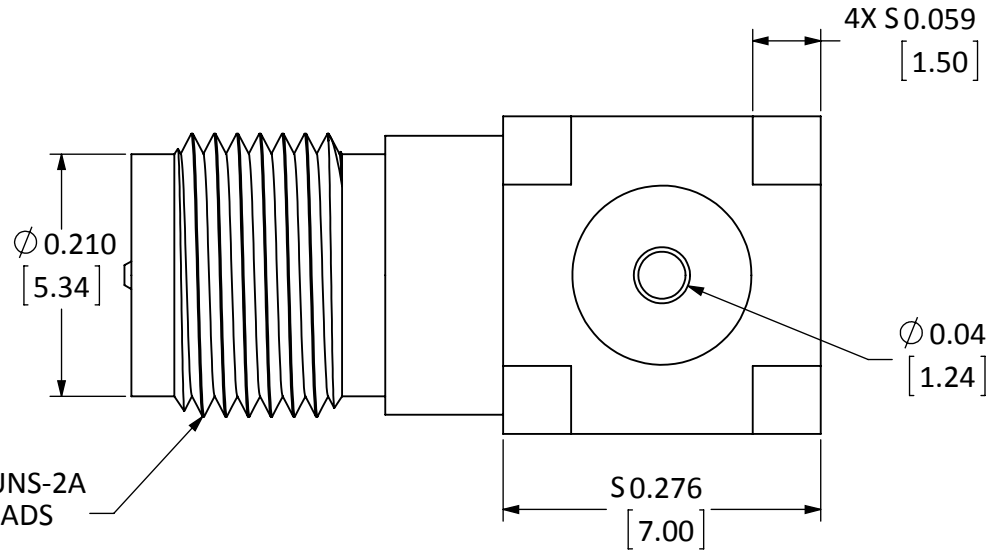

BOTTOM VIEW

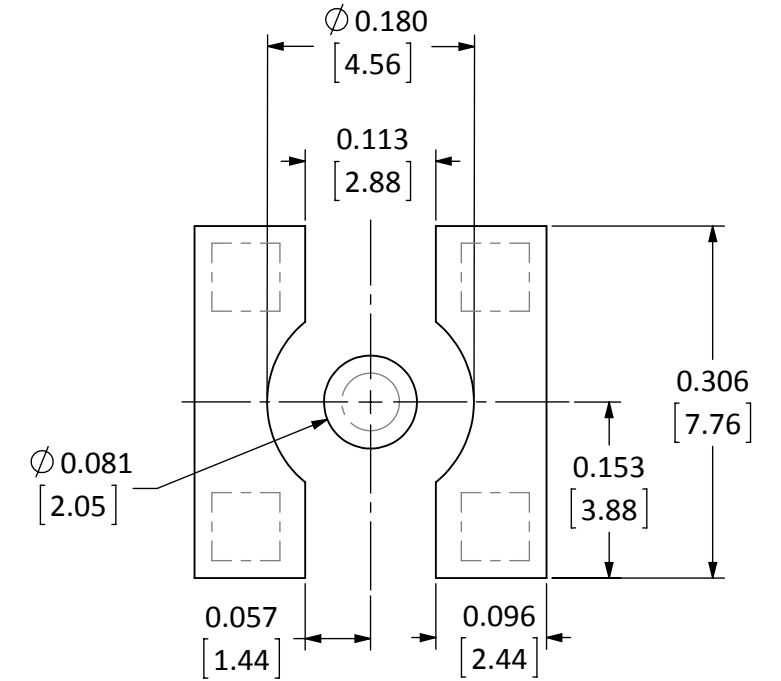

RECOMMENDED FOOTPRINT

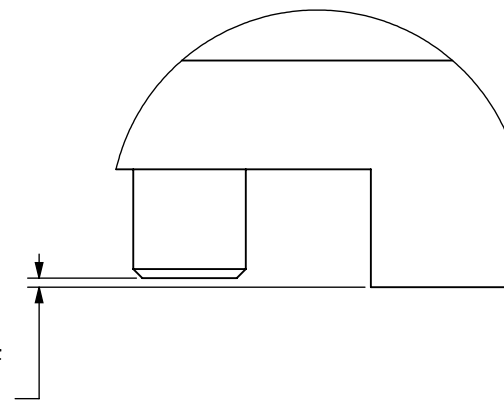

DETAIL A
SCALE 12 : 1

0.004
0.000
[0.10]
[0.00]
CENTER CONTACT TO MOUNTING PLANE STAND-OFF

NOTES: (UNLESS OTHERWISE SPECIFIED)

1. ALL DIMENSIONS ARE IN INCHES [mm].
2. DIMENSIONS APPLY AFTER FINISHING.
3. MANUFACTURE TO BE COMPLIANT WITH EU RoHS DIRECTIVE, USE MATERIALS THAT DO NOT CONTAIN REACH SUBSTANCES OF VERY HIGH CONCERN >1000ppm, AND USE DRC CONFLICT-FREE SOURCED MATERIALS.
4. SAFETY BREAK ALL SHARP CORNERS AND EDGES .02 MAXIMUM.

WARNING: THIS DRAWING CONTAINS PROPRIETARY INFORMATION THAT IS THE SOLE PROPERTY OF LINX TECHNOLOGIES, AND SHALL BE TREATED AS SUCH. NO DISCLOSURE OR REPRODUCTION OF THIS DOCUMENT IS PERMITTED, IN WHOLE OR IN PART, WITHOUT THE EXPRESS WRITTEN PERMISSION OF LINX TECHNOLOGIES OR ITS DESIGNATED AGENTS.

Linx

159 ORT LANE
MERLIN, OR 97532

TITLE:
**RP-SMA FEMALE RIGHT
ANGLE SURFACE MOUNT**

| | | |
|-----------|---|-------------|
| MATERIAL: | INTERPRET DIMENSIONS AND TOLERANCES PER ASME Y14.5. | PROJECTION: |
| FINISH: | SURFACE FINISH: $\sqrt{}$ ANGLES: $\pm 1^\circ$ | |
| | TOLERANCES: .X $\pm .1$.XX $\pm .01$.XXX $\pm .005$ | |
| | DRAWN: B.MURPHY DT: 25-APR-12 | |
| | ENGR: S.HOGAN DT: 25-APR-12 | |

| | | |
|------------|----------------------|--------------|
| SIZE | DWG. NO. | REV |
| B | CONREVSMA002-SMD | E |
| SCALE: 6:1 | DO NOT SCALE DRAWING | SHEET 1 OF 1 |