



Chipsmall Limited consists of a professional team with an average of over 10 year of expertise in the distribution of electronic components. Based in Hongkong, we have already established firm and mutual-benefit business relationships with customers from,Europe,America and south Asia,supplying obsolete and hard-to-find components to meet their specific needs.

With the principle of “Quality Parts,Customers Priority,Honest Operation,and Considerate Service”,our business mainly focus on the distribution of electronic components. Line cards we deal with include Microchip,ALPS,ROHM,Xilinx,Pulse,ON,Everlight and Freescale. Main products comprise IC,Modules,Potentiometer,IC Socket,Relay,Connector.Our parts cover such applications as commercial,industrial, and automotives areas.

We are looking forward to setting up business relationship with you and hope to provide you with the best service and solution. Let us make a better world for our industry!



Contact us

Tel: +86-755-8981 8866 Fax: +86-755-8427 6832

Email & Skype: info@chipsmall.com Web: www.chipsmall.com

Address: A1208, Overseas Decoration Building, #122 Zhenhua RD., Futian, Shenzhen, China



Description	Material	Finish
Body	Brass	Nickel
Socket	BE CU	Gold
Insulation	PTFE	N/A
Washer	PH Bronze	Nickel
Gasket	SI Rubber	Rubber
Crimp Ring	Brass	Nickel
Insulator	PTFE	N/A
Cover	Brass	Nickel
Heat Shrink	Polyolefin	Black

REVISIONS			
REV	DESCRIPTION	DATE	APPV
B	Changed crimp ring dimensions; added heat shrink, new title block and assembly instructions	2-JUL-12	SAH

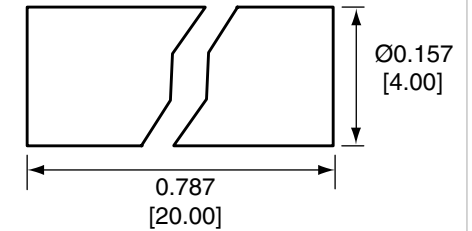
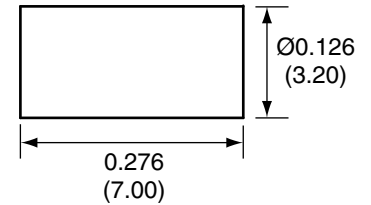
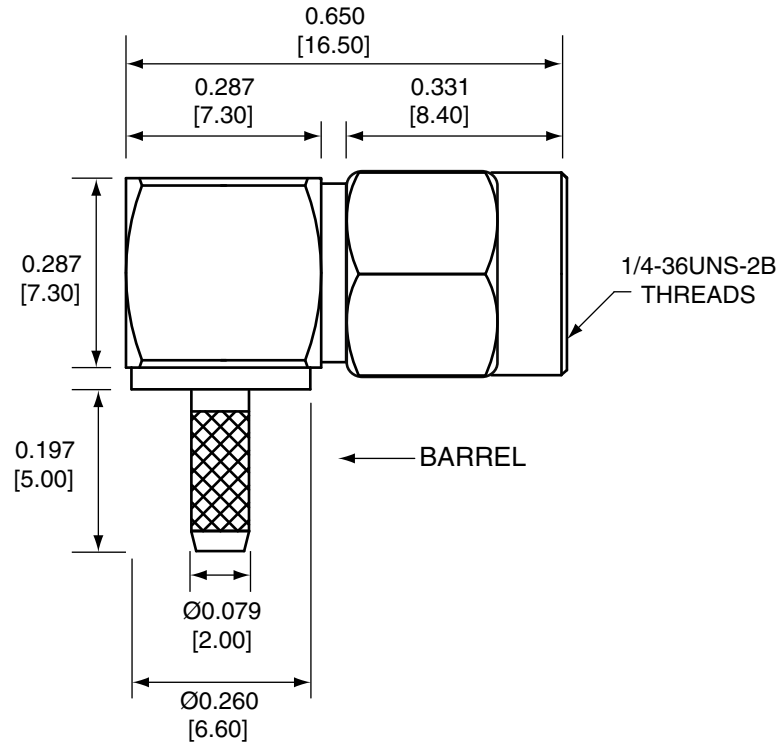
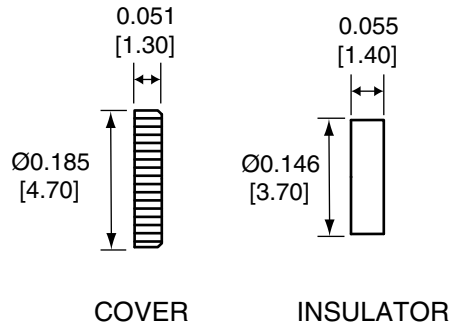

CONREV SMA012-R178 ASSEMBLY INSTRUCTIONS

- Strip the cable to the recommended dimensions.
- Slip heat shrink and crimp ring onto stripped cable.
- Slide the cable into the body until the center conductor is centered in the fork.
- Push the braided shield over the barrel.
- Solder the center conductor into the center of the fork.
- Slide the crimp ring over the shield and crimp with a 0.100" hex crimp tool.
- Trim off any excess shield wire sticking out from the ring.
- Slip the heat shrink over the crimp ring until it is against the body and shrink.
- Insert insulator into body.
- Push the cover into the opening.

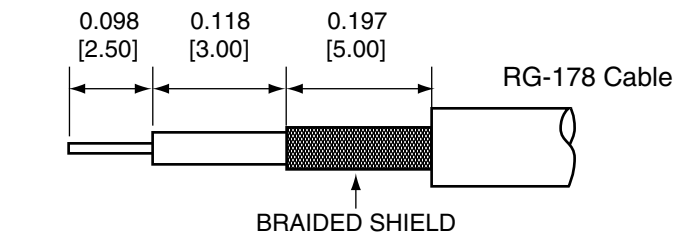

RECOMMENDED CABLE STRIPPING DIMENSIONS

SIDE VIEW

NOTES: (UNLESS OTHERWISE SPECIFIED)

- ALL DIMENSIONS ARE IN INCHES [mm].
- DIMENSIONS APPLY AFTER FINISHING.
- MANUFACTURE TO BE COMPLIANT WITH EU RoHS DIRECTIVE.
- SAFETY BREAK ALL SHARP CORNERS AND EDGES .02 MAXIMUM.

WARNING: THIS DRAWING CONTAINS PROPRIETARY INFORMATION THAT IS THE SOLE PROPERTY OF LINX TECHNOLOGIES, AND SHALL BE TREATED AS SUCH. NO DISCLOSURE OR REPRODUCTION OF THIS DOCUMENT IS PERMITTED, IN WHOLE OR IN PART, WITHOUT THE EXPRESS WRITTEN PERMISSION OF LINX TECHNOLOGIES OR ITS DESIGNATED AGENTS.

MATERIAL:	TOLERANCES:	PROJECTION:
	.020 [0.50]-.200 [5.00]= ±.008 [0.20] .200 [5.00]-1.200 [30.00]= ±.016 [0.40] 1.20 [30.0]-4.75 [120.0]= ±.024 [0.60] 4.75 [120.0]-12.40 [315.0]= ±.040 [1.0]	ANGLER: ±1°
FINISH:	DRAWN: B.MURPHY	DT: 2-JUL-12
	ENGR: S.HOGAN	DT: 2-JUL-12

Linx

159 ORT LANE
MERLIN, OR 97532

TITLE:
RP-SMA MALE RIGHT ANGLE
CABLE END CRIMP FOR RG178 CABLE

SIZE	DWG. NO.	REV
A	CONREV SMA012-R178	B
SCALE: 2:1	DO NOT SCALE DRAWING	SHEET 1 OF 1