



Chipsmall Limited consists of a professional team with an average of over 10 year of expertise in the distribution of electronic components. Based in Hongkong, we have already established firm and mutual-benefit business relationships with customers from,Europe,America and south Asia,supplying obsolete and hard-to-find components to meet their specific needs.

With the principle of “Quality Parts,Customers Priority,Honest Operation,and Considerate Service”,our business mainly focus on the distribution of electronic components. Line cards we deal with include Microchip,ALPS,ROHM,Xilinx,Pulse,ON,Everlight and Freescale. Main products comprise IC,Modules,Potentiometer,IC Socket,Relay,Connector.Our parts cover such applications as commercial,industrial, and automotives areas.

We are looking forward to setting up business relationship with you and hope to provide you with the best service and solution. Let us make a better world for our industry!



Contact us

Tel: +86-755-8981 8866 Fax: +86-755-8427 6832

Email & Skype: info@chipsmall.com Web: www.chipsmall.com

Address: A1208, Overseas Decoration Building, #122 Zhenhua RD., Futian, Shenzhen, China



Description	Material	Finish
Body	Brass	Nickel
Socket	BE CU	Gold
Insulation	PTFE	N/A
Washer	PH Bronze	Nickel
Gasket	SI Rubber	Rubber
Crimp Ring	Brass	Nickel
Insulator	PTFE	N/A
Cover	Brass	Nickel
Heat Shrink	Polyolefin	Black

REVISIONS			
REV	DESCRIPTION	DATE	APPV
B	Added new title block, heat shrink and instructions; updated cover and insulator drawings	2-JUL-12	SAH

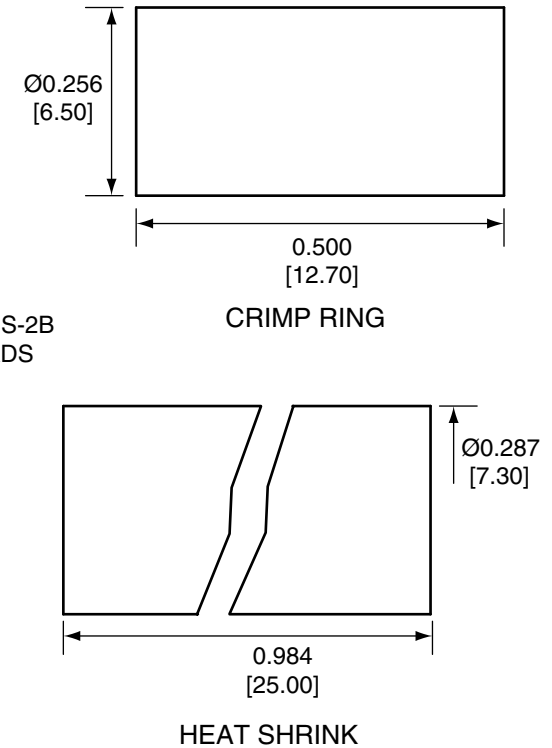
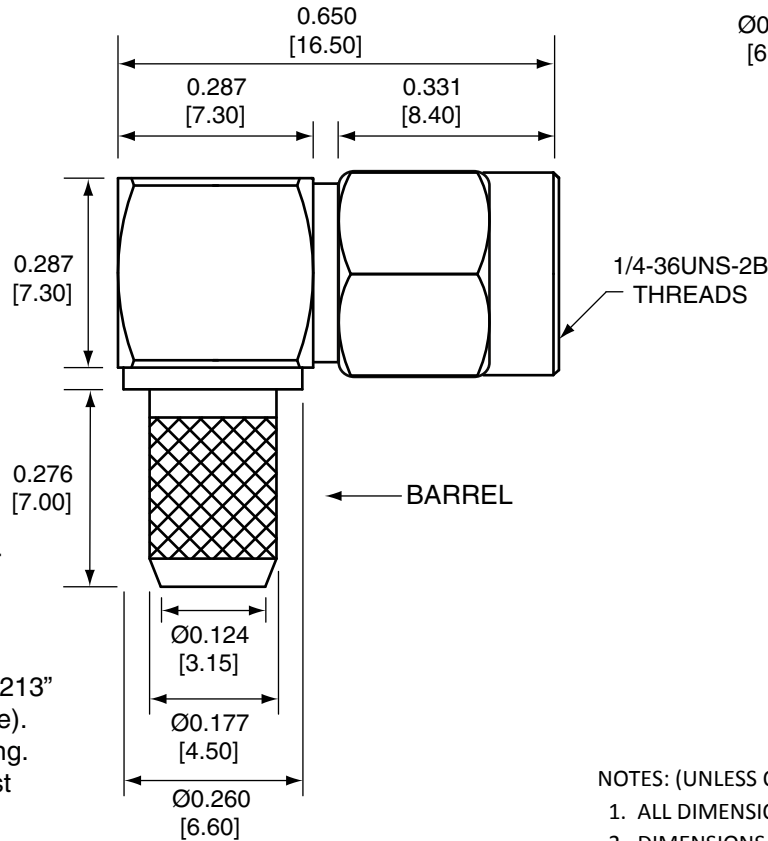
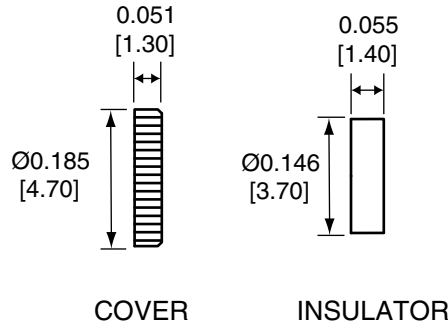

CONREVSMA012-R58 ASSEMBLY INSTRUCTIONS

- Strip cable to recommended dimensions.
- Slip heat shrink and crimp ring onto stripped cable.
- Slide the cable into the body until the center conductor is centered in the fork.
- Push the braided shield over the barrel.
- Solder the center conductor into the center of the fork.
- Slide the crimp ring over the shield and crimp with a 0.213" hex crimp tool (or one labeled for use with RG-58 cable).
- Trim off any excess shield wire sticking out from the ring.
- Slip the heat shrink over the crimp ring until it is against the body and shrink.
- Insert insulator into body.
- Push the cover into the opening.

NOTES: (UNLESS OTHERWISE SPECIFIED)

- ALL DIMENSIONS ARE IN INCHES [mm].
- DIMENSIONS APPLY AFTER FINISHING.
- MANUFACTURE TO BE COMPLIANT WITH EU RoHS DIRECTIVE.
- SAFETY BREAK ALL SHARP CORNERS AND EDGES .02 MAXIMUM.

SIDE VIEW

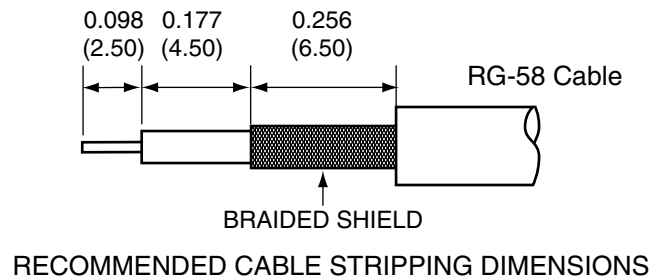

WARNING: THIS DRAWING CONTAINS PROPRIETARY INFORMATION THAT IS THE SOLE PROPERTY OF LINX TECHNOLOGIES, AND SHALL BE TREATED AS SUCH. NO DISCLOSURE OR REPRODUCTION OF THIS DOCUMENT IS PERMITTED, IN WHOLE OR IN PART, WITHOUT THE EXPRESS WRITTEN PERMISSION OF LINX TECHNOLOGIES OR ITS DESIGNATED AGENTS.

MATERIAL:	TOLERANCES: .020 [0.50]-.200 [5.00]= ±.008 [0.20] .200 [5.00]-1.200 [30.00]= ±.016 [0.40] 1.20 [30.0]-4.75 [120.0]= ±.024 [0.60] 4.75 [120.0]-12.40 [315.0]= ±.040 [1.0]	PROJECTION:
FINISH:	DRAWN: B.MURPHY	DT: 2-JUL-12
	ENGR: S.HOGAN	DT: 2-JUL-12

		159 ORT LANE MERLIN, OR 97532	
TITLE: RP-SMA MALE RIGHT ANGLE CABLE END CRIMP FOR RG58 CABLE			
SIZE A	DWG. NO. CONREVSMA012-R58	REV B	
SCALE: 2:1	DO NOT SCALE DRAWING	SHEET 1 OF 1	