



Chipsmall Limited consists of a professional team with an average of over 10 year of expertise in the distribution of electronic components. Based in Hongkong, we have already established firm and mutual-benefit business relationships with customers from,Europe,America and south Asia,supplying obsolete and hard-to-find components to meet their specific needs.

With the principle of “Quality Parts,Customers Priority,Honest Operation,and Considerate Service”,our business mainly focus on the distribution of electronic components. Line cards we deal with include Microchip,ALPS,ROHM,Xilinx,Pulse,ON,Everlight and Freescale. Main products comprise IC,Modules,Potentiometer,IC Socket,Relay,Connector.Our parts cover such applications as commercial,industrial, and automotives areas.

We are looking forward to setting up business relationship with you and hope to provide you with the best service and solution. Let us make a better world for our industry!



## Contact us

Tel: +86-755-8981 8866 Fax: +86-755-8427 6832

Email & Skype: info@chipsmall.com Web: www.chipsmall.com

Address: A1208, Overseas Decoration Building, #122 Zhenhua RD., Futian, Shenzhen, China



| DESCRIPTION | MATERIAL | FINISH |
|-------------|----------|--------|
| BODY        | BRASS    | NICKEL |
| SOCKET      | BeCu     | GOLD   |
| INSULATION  | PTFE     | N/A    |
| WASHER      | BRASS    | NICKEL |
| NUT         | BRASS    | NICKEL |

| REVISIONS |   |          |      |
|-----------|---|----------|------|
| REV       | DESCRIPTION   | DATE     | APPV |
| B         | ADDED NUT AND WASHER                                    | 2/18/10  | CJ   |
| C         | UPDATED FOOTPRINT AND DIMENSIONS; ADDED NEW TITLE BLOCK | 2-JUL-12 | SAH  |
| D         | ADDED DIMPLE TO PART                                    | 3-JUN-13 | SAH  |

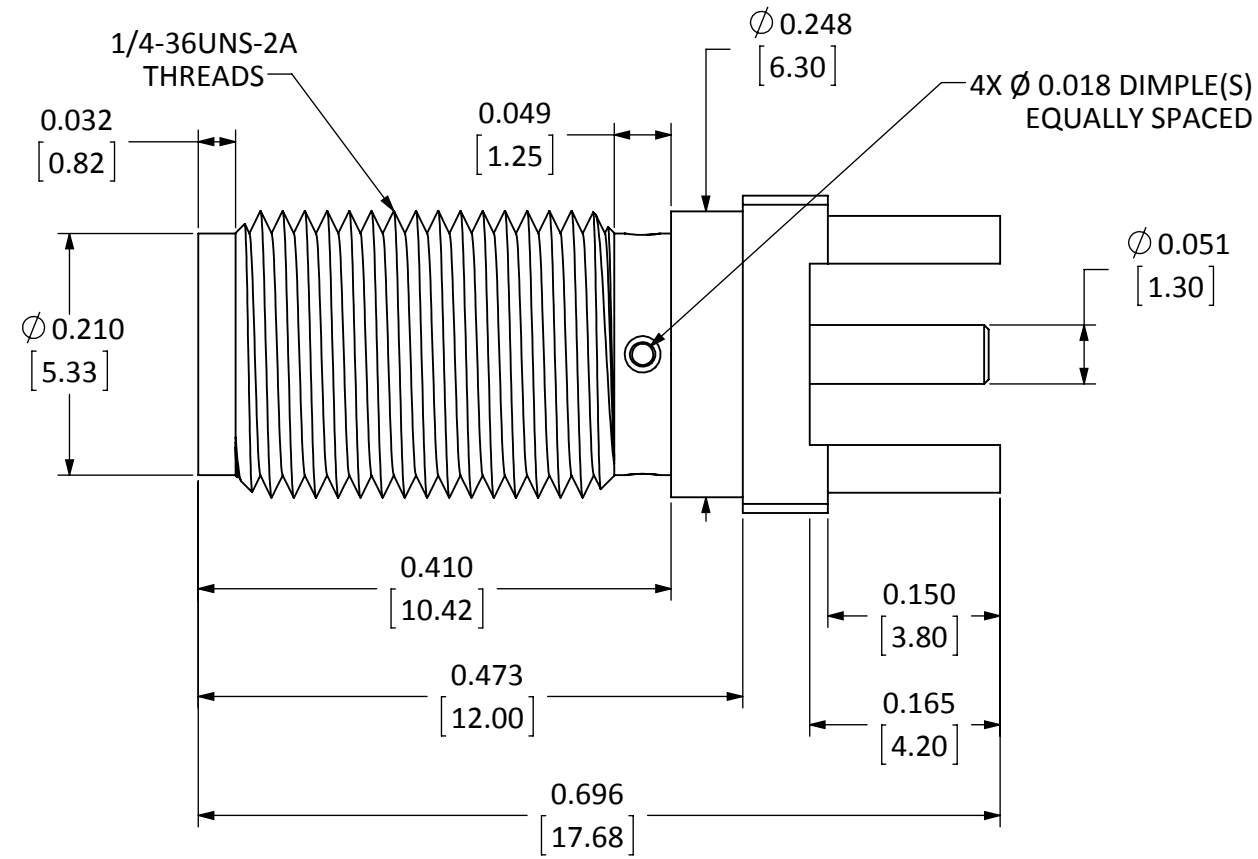

SIDE VIEW

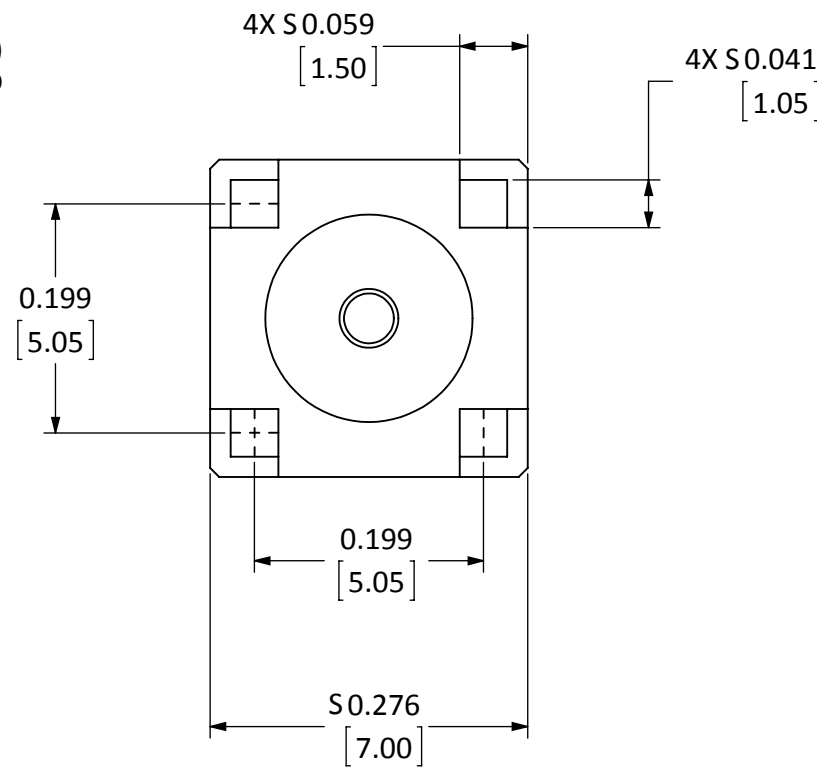

BACK VIEW

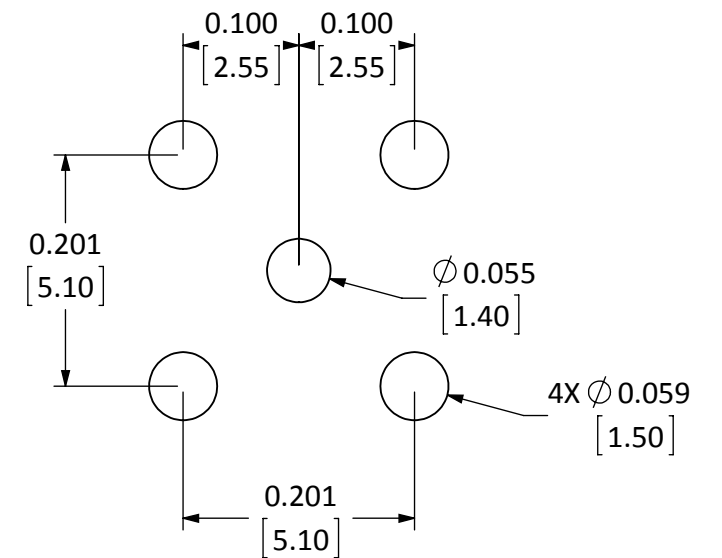

RECOMMENDED FOOTPRINT

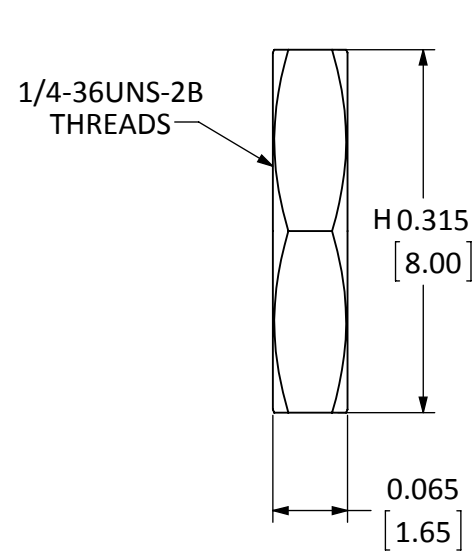

NUT

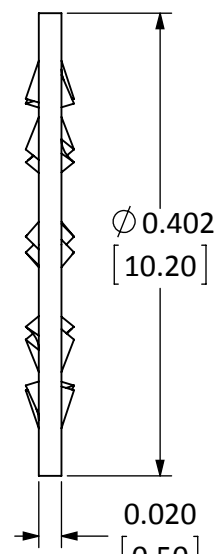

WASHER

- NOTES: (UNLESS OTHERWISE SPECIFIED)
1. ALL DIMENSIONS ARE IN INCHES [mm].
  2. DIMENSIONS APPLY AFTER FINISHING.
  3. MANUFACTURE TO BE COMPLIANT WITH EU RoHS DIRECTIVE.
  4. SAFETY BREAK ALL SHARP CORNERS AND EDGES .02 MAXIMUM.

**WARNING:** THIS DRAWING CONTAINS PROPRIETARY INFORMATION THAT IS THE SOLE PROPERTY OF LINX TECHNOLOGIES, AND SHALL BE TREATED AS SUCH. NO DISCLOSURE OR REPRODUCTION OF THIS DOCUMENT IS PERMITTED, IN WHOLE OR IN PART, WITHOUT THE EXPRESS WRITTEN PERMISSION OF LINX TECHNOLOGIES OR ITS DESIGNATED AGENTS.

**Linx**

159 ORT LANE  
MERLIN, OR 97532

TITLE:  
**SMA FEMALE PCB MOUNT  
EXTENDED**

|                 |   |             |
|-----------------|---|-------------|
| MATERIAL:       | INTERPRET DIMENSIONS AND TOLERANCES PER ASME Y14.5.     | PROJECTION: |
| FINISH:         | SURFACE FINISH: $\sqrt{\text{ }}$ ANGLES: $\pm 1^\circ$ |             |
|                 | TOLERANCES: .X $\pm .1$ .XX $\pm .01$ .XXX $\pm .005$   |             |
| DRAWN: B.MURPHY | DT: 8-MAR-13  |             |
| ENGR: S.HOGAN   | DT: 3-JUN-13  |             |

|            |                      |              |
|------------|----------------------|--------------|
| SIZE       | DWG. NO.             | REV          |
| <b>B</b>   | CONSMA008            | <b>D</b>     |
| SCALE: 6:1 | DO NOT SCALE DRAWING | SHEET 1 OF 1 |