



Chipsmall Limited consists of a professional team with an average of over 10 year of expertise in the distribution of electronic components. Based in Hongkong, we have already established firm and mutual-benefit business relationships with customers from,Europe,America and south Asia,supplying obsolete and hard-to-find components to meet their specific needs.

With the principle of “Quality Parts,Customers Priority,Honest Operation,and Considerate Service”,our business mainly focus on the distribution of electronic components. Line cards we deal with include Microchip,ALPS,ROHM,Xilinx,Pulse,ON,Everlight and Freescale. Main products comprise IC,Modules,Potentiometer,IC Socket,Relay,Connector.Our parts cover such applications as commercial,industrial, and automotives areas.

We are looking forward to setting up business relationship with you and hope to provide you with the best service and solution. Let us make a better world for our industry!



Contact us

Tel: +86-755-8981 8866 Fax: +86-755-8427 6832

Email & Skype: info@chipsmall.com Web: www.chipsmall.com

Address: A1208, Overseas Decoration Building, #122 Zhenhua RD., Futian, Shenzhen, China



Description

The CP-V413PS is a Video-Grade wall plate splitter designed to expedite the service delivery and improve the performance of digital subscriber line (xDSL) services over plain old telephone service (POTS).

The CP-V413PS is ideal for digital video applications. The splitter uses Enhanced Transient Signal Suppression (ETSS)[™] for short and long loops to minimize bit and frame errors during ringing and on/off-hook transitions. ETSS provides maximum data throughput and video quality for ADSL2+, VDSL and VDSL2 applications.

In addition, the CP-V413PS splitter filters all telephones, facsimile (fax) machines, answering machines, and other telephone equipment. Its design electronically isolates the high-speed xDSL data stream from voice-band frequencies to provide premium voice quality and optimal DSL data rates.

Applications

The CP-V413PS is installed as the first telephone jack in the subscribers' premises to isolate all voice-band equipment connected to that line. This product is also ideal for users and hotel operators who wish to eliminate the use of modular DSL filters.

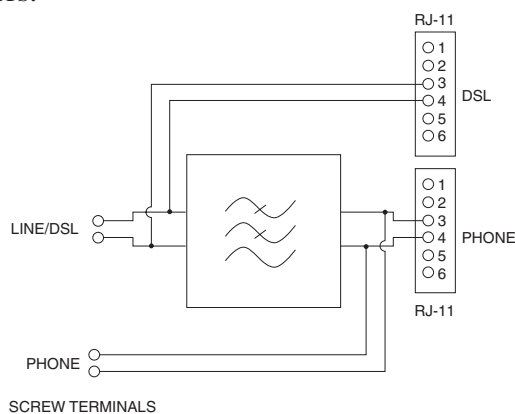

CP-V413PS Block Schematic



CP-V413PS VDSL2 Video-Grade CPE Splitter

The CP-V413PS Video-Grade CPE Splitter is one of many splitters and filters manufactured by Excelsus, a brand of Pulse, for digital services within homes, offices, and hotels. Excelsus is the number one selling brand of DSL filters and splitters worldwide.

Features

- Isolates telephone equipment impedances from DSL
- Blocks DSL signals from voice-band equipment
- Minimizes bit and frame error rates to maximize data throughput and video quality
- Compliant with ANSI T1.413-1998 Issue 2 Annex E and ITU-T G.992.1 E.2
- Environmentally hardened and sealed
- Compatible with ADSL, ADSL+2, VDSL VDSL2, V.90 and Metallic Loop Testing
- UL / CSA 60950, FCC CFR 47 Part 68, and IC CS-03

Z-BLOCKER® CP-V413PS VDSL2 Video-Grade NID Splitter Module

Electrical	
DC Loop Current	0 to 100 mA
DC Voltage (tip-to-ring)	-60 Vdc
Ringing Signals	103 Vrms, 20 to 30 Hz
DC Resistance (tip-to-ring)	< 25 Ω with line open
DC Resistance (tip-to-ground, ring-to-ground)	\geq 5 m Ω with line open
POTS Insertion Loss	< 1.0 dB @ 1004 Hz; Short Loop < 0.75 dB @ 1004 Hz; Long Loop
DSL to Line Insertion Loss	< 0.5 dB; 25 KHz to 30 MHz
Attenuation Distortion	+1.5 to -1.5 dB; 200 to 3400 Hz, Short Loop
	+2.0 to -2.0 dB; 3400 to 4000 Hz, Short Loop
	+0.5 to -1.5 dB; 200 to 3400 Hz, Long Loop
	+1.0 to -1.5 dB; 3400 to 4000 Hz, Long Loop
Delay Distortion	< 200 μ sec; 600 to 3200 Hz, Short and Long Loops
	< 250 μ sec; 200 to 4000 Hz, Short and Long Loops
Return Loss	> 6 dB ERL, > 5 dB SRL-L
	> 3 dB SRL-H across frequency spectrum
	> 2 dB SRL-H for single frequencies
Intermodulation Distortion	\geq 57 dB second order
	\geq 60 dB second order
Longitudinal Balance (PSTN to Line port and Line port to PSTN; 25mA DC bias with xDSL port shorted)	> 58 dB; 200 to 1000 Hz
tip-to-ring Capacitance (POTS or PSTN port)	< 300 nF; 20 to 30 Hz
Capacitance-to-Ground (POTS or PSTN port)	< 1.0 nF; 20 to 30 Hz
xDSL Band Attenuation (input level = 1 dBm)	> 55 dB; 25 KHz to 30 MHz
Input Impedance (input level = 10 dBm)	< 0.25 dB; 30 to 1104 KHz
Mechanical	
Connectors: screw terminals for LINE/DSL and PHONE RJ11 Jacks for DSL and PHONE	
Splitter Dimensions: Height: 4.6in. (116mm), Width: 2.8in. (71.3mm), Depth: 1.6in. (30mm)	
Splitter Weight:	2.4 oz. (68g)
Environmental	
Relative Humidity	0 to 95%, non-condensing
Video: Upstream and downstream CRC's	\leq 1
Safety and Compliance	UL / CSA 60950, FCC CFR 47 Part 68, IC CS-03
PULSE Certified to be Video-Grade and compliant to Broad Band Forum TR127	