



Chipsmall Limited consists of a professional team with an average of over 10 year of expertise in the distribution of electronic components. Based in Hongkong, we have already established firm and mutual-benefit business relationships with customers from,Europe,America and south Asia,supplying obsolete and hard-to-find components to meet their specific needs.

With the principle of “Quality Parts,Customers Priority,Honest Operation,and Considerate Service”,our business mainly focus on the distribution of electronic components. Line cards we deal with include Microchip,ALPS,ROHM,Xilinx,Pulse,ON,Everlight and Freescale. Main products comprise IC,Modules,Potentiometer,IC Socket,Relay,Connector.Our parts cover such applications as commercial,industrial, and automotives areas.

We are looking forward to setting up business relationship with you and hope to provide you with the best service and solution. Let us make a better world for our industry!



Contact us

Tel: +86-755-8981 8866 Fax: +86-755-8427 6832

Email & Skype: info@chipsmall.com Web: www.chipsmall.com

Address: A1208, Overseas Decoration Building, #122 Zhenhua RD., Futian, Shenzhen, China



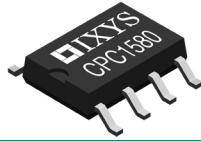

Features

- Drives External Power MOSFET
- Low LED Current (2.5mA)
- Requires No External Power Supply
- Load Voltages up to 65V
- High Reliability
- Small 8-pin Surface Mount Package
- 3750V_{rms} Input/Output Isolation

Applications

- Industrial Controls
- Instrumentation
- Medical Equipment Isolation
- Electronic Switching
- I/O Subsystems
- Appliances

Approvals

- UL recognized component: File # E76270

Description

The CPC1580 optical gate driver provides isolated control of a discrete power MOSFET transistor without the need of an external power supply. Control of the power MOSFET transistor is accomplished by the application of sufficient input LED current to activate the driver circuitry.

On the load side, an external storage capacitor and an internal bootstrap diode enable the internal photovoltaic and gate driver circuitry to provide fast output switching characteristics by supplying the charge necessary to satisfy the MOSFET's bias requirements.

Provided in a small 8-pin package, the CPC1580 provides 3750V_{rms} of input-to-output isolation.

Ordering Information

Part	Description
CPC1580P	8-Pin Flatpack (50/Tube)
CPC1580PTR	8-Pin Flatpack (1000/Reel)

Figure 1. CPC1580 DC Application Circuit Diagram

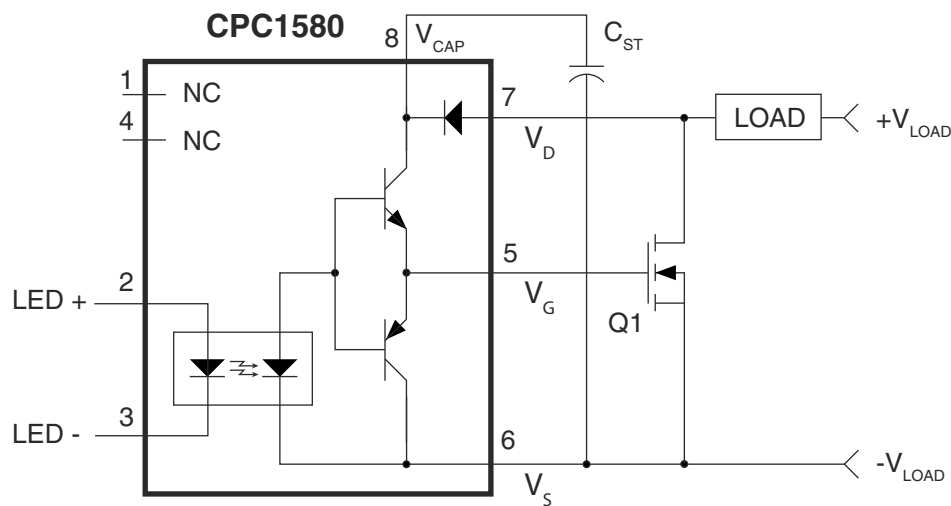

1. Specifications	3
1.1 Package Pinout	3
1.2 Pin Description	3
1.3 Absolute Maximum Ratings	3
1.4 ESD Rating	3
1.5 Recommended Operating Conditions	3
1.6 General Conditions	4
1.7 Electrical Specifications	4
1.8 Performance Data	5
2. Introduction	6
3. Functional Description	6
4. Device Configuration	6
4.1 LED Resistor	6
4.2 Storage Capacitor Selection	6
4.3 Transistor Selection	7
4.3.1 Transistor Switching Characteristics	7
5. CPC1580 Over-Voltage Protection	8
5.1 Other Protection Techniques	9
6. Application Switching Losses	9
6.1 Resistive Load Losses: The Ideal Case	10
6.2 Inductive/Resistive Loads	10
6.3 Capacitive Loads	10
6.4 dV/dt Characteristics	10
7. Design Switching Frequency	10
8. Manufacturing Information	12
8.1 Moisture Sensitivity	12
8.2 ESD Sensitivity	12
8.3 Reflow Profile	12
8.4 Board Wash	12
8.5 CPC1580P Package	13
8.6 CPC1580PTR Tape and Reel Specification	13

1. Specifications

1.1 Package Pinout

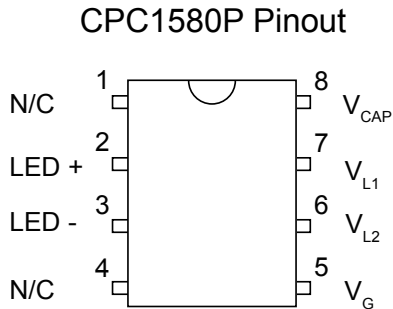

1.2 Pin Description

Pin#	Name	Description
1	N/C	Not connected
2	LED +	Positive input to LED
3	LED -	Negative input to LED
4	N/C	Not connected
5	V _G	Output, MOSFET Gate Control
6	V _{L2}	-Load Voltage DC, ± Load Voltage AC
7	V _{L1}	+Load Voltage DC, ± Load Voltage AC
8	V _{CAP}	Storage Capacitor

1.3 Absolute Maximum Ratings

Absolute maximum electrical ratings are at 25°C.

Parameter	Rating	Units
Blocking Voltage (V _{DS})	65	V _P
Reverse Input Voltage	5	V
Input Control Current	50	mA
Peak (10ms)	1	A
Input Power Dissipation ¹	150	mW
Output Power Dissipation ²	500	mW
Isolation Voltage (Input to Output)	3750	V _{rms}
Operational Temperature	-40 to +110	°C
Storage Temperature	-40 to +125	°C

¹ Derate linearly 1.33mW/°C

² Derate linearly 6.0mW/°C

Absolute maximum ratings are stress ratings. Stresses in excess of these ratings can cause permanent damage to the device. Functional operation of the device at conditions beyond those indicated in the operational sections of this data sheet is not implied.

1.4 ESD Rating

ESD Rating (Human Body Model)
1000 V

1.5 Recommended Operating Conditions

Parameter	Symbol	Min	Max	Units
Load Voltage	V _L	15	65	V
Input Control Current	I _F	2.5	10	mA
Forward Voltage Drop	V _F	1	1.4	V
Operating Temperature	T _A	-40	+110	°C

1.6 General Conditions

Unless otherwise specified, minimum and maximum values are guaranteed by production testing. Typical values are characteristic of the device at 25°C, and are the result of engineering evaluations. They are provided for informational purposes only, and are not part of the manufacturing testing requirements. Unless otherwise noted, all electrical specifications are listed for T_A=25°C.

1.7 Electrical Specifications

Parameter	Conditions	Symbol	Min	Typ	Max	Units
Load Side Characteristics						
Gate Voltage	I _F =2.5mA	V _{GS}	7.5	8.2	12	V
	I _F =5mA			8.7		
	I _F =10mA			9.1		
	I _F =2.5mA -40°C<T _A <110°C		4.2	-	14.4	
Capacitor Voltage	10V<V _{DS} <65V	V _{CAP}	V _{DS} -0.8	-	V _{DS} -0.2	V
Gate Drive Capability	I _F =2.5mA, V _{GS} =0V, V _{CAP} =15V	I _{G_source}	2	3.6	7	mA
	I _F =0mA, V _{GS} =8V, V _{CAP} =8V	I _{G_sink}	0.35	0.47	1	
	I _F =0mA, V _{GS} =4V, V _{CAP} =4V		0.16	0.22		
	I _F =0mA, V _{GS} =2V, V _{CAP} =2V		0.06	0.09		
Turn-On Delay	V _{DS} =48V, V _{GS} =4V, C _{VG} =4nF	t _{on}	1			μs
	I _F =2.5mA			48	140	
	I _F =5mA			16	40	
	I _F =10mA			7	20	
Turn-Off Delay	V _{DS} =48V, V _{GS} =2V, C _{VG} =4nF	t _{off1}	40			μs
	I _F =2.5mA			150	400	
	I _F =5mA			175		
	I _F =10mA			195		
	V _{DS} =48V, V _{GS} =1V, C _{VG} =4nF	t _{off2}	40			μs
	I _F =2.5mA			240	600	
	I _F =5mA			270		
	I _F =10mA			290		
Off-State Leakage Current	V _{DS} =65V	I _{DS}	-	-	1	μA
LED Characteristics						
Forward Voltage Drop	I _F =5mA	V _F	1	1.27	1.4	V
Input Dropout Current	V _{GS} =1V	I _F	0.2	0.7	1	mA
Reverse Bias Leakage Current	V _R =5V	I _R	-	-	10	μA
Common Characteristics						
Input to Output Capacitance	-	C _{I/O}	-	3	-	pF

1.8 Performance Data

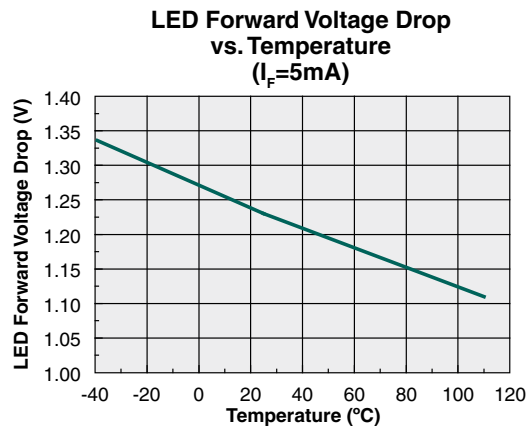
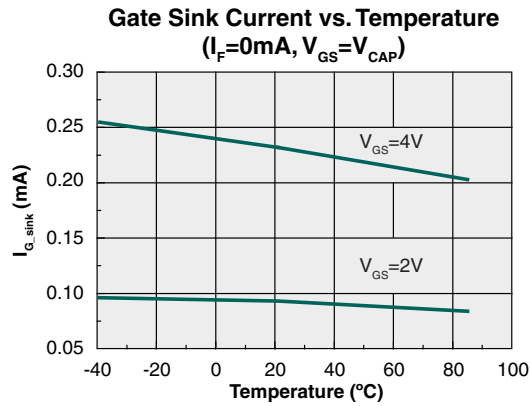
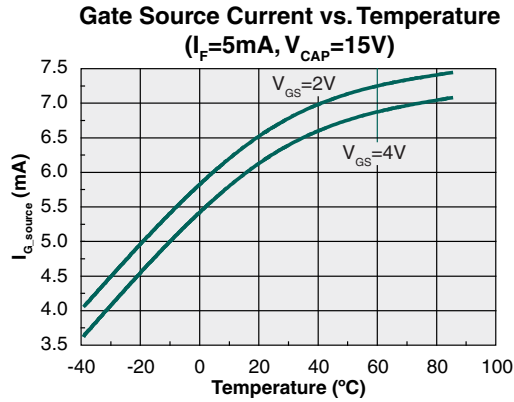

2. Introduction

The CPC1580 Isolated Gate Driver uses an efficient optocoupler design to provide remote gate drive current to a MOSFET, while providing 3750V_{rms} of isolation between the LED control current input and the MOSFET gate drive output. The CPC1580 is used in conjunction with a MOSFET transistor for remote switching of DC loads (Figure 1) and two MOSFETS and a diode at low-frequency AC rates (Figure 2) where isolated power is unavailable.

By selecting a few external components, the charge capacitor and resistors, the designer has control over the operating parameters of the CPC1580 circuit, and can customize the circuit to accommodate the requirements of a wide selection of MOSFETs.

The designer just needs to know the MOSFET total gate charge (Q_G), and with this information a capacitor can be chosen. The capacitance of the storage capacitor, C_{ST}, should be greater than or equal to Q_G.

3. Functional Description

The CPC1580 is operational when sufficient input control current is flowing, the LED is turned on, and the gate current is flowing. The LED illuminates the photovoltaics (converts light into electrical power, or photocurrent), which provides current to turn on the NPN bipolar transistor. The NPN transistor then allows for charge to go to the gate of the MOSFET. When an external storage capacitor is added to the CPC1580, the photocurrent that is produced turns on the NPN bipolar transistor and provides the charge (I x t = Q) plus the charge of the capacitor to turn on the MOSFET rapidly. If sufficient input control current is not flowing, the LED is turned off, and gate current is not flowing. The LED is off due to the V_F << the minimum forward voltage required and not enough current being applied. This turns on the PNP bipolar transistor, which provides a path for Q_G to discharge to V_S.

When V_L is first applied, the external storage capacitor begins to charge. The value of the storage capacitor should be equal to or greater than the MOSFET gate capacitance: this will ensure proper operation. The charge is sent through a bootstrap diode to prevent the charge from escaping and discharging through a turned-on MOSFET. The input control current is applied, then the charge is transferred from the storage capacitor through the NPN bipolar transistor,

along with the charge from the photovoltaics, to the MOSFET gate to accomplish a rapid turn-on. After the capacitor has discharged and the MOSFET has turned on, the photocurrent from the input optocoupler continues to flow into the gate to keep the MOSFET turned on.

When the input control current is removed, the gate current stops flowing and the PNP bipolar transistor is on and is discharging the MOSFET gate. The MOSFET is now off. At this point, the capacitor begins to recharge for the next turn-on cycle.

4. Device Configuration

4.1 LED Resistor

LED resistor selection should comply with the recommended operating conditions. This will provide reliability to the design, and should help with temperature. The CPC1580 is capable of being operated at up to the maximum ratings, but this is not recommended. It will shorten the life-span of the device and could cause temperature problems that will produce inaccuracies. The reason for using a higher I_F current is to provide for faster turn-on. Proper design will have to be used to decide on the needs of the application. The equation used to calculate the resistor value:

$$R_{LED} = \frac{V_{IN} - V_F}{I_F}$$

- I_F = Input Control Current
- V_{IN} = Input Power Source
- V_F = Forward Voltage Drop of LED
- R_{LED} = Input Resistor connected to LED

4.2 Storage Capacitor Selection

The storage capacitor (C_{ST}) enables the part to turn on quickly by holding a reservoir of charge to be transferred to the gate of the MOSFET. The turn-off cycle does not depend on the storage capacitor.

The equation used to calculate the value of the charge storage capacitor is:

$$C_{ST} \geq \frac{Q_G}{V_{LOAD} - V_{CAP}} \quad (\text{FARADS})$$

Where $V_{CAP} \geq 15V$ and Q_G is the total gate charge (listed in the MOSFET data sheet).

The storage capacitor needs to deliver enough charge to the gate without going below the 15V required for switching the MOSFET. This means that V_{LOAD} must equal, at a minimum, 15.7V. The part can operate at a lower voltage, but the MOSFETs will be turned on slowly.

The proper selection of a capacitor is important. The rated voltage should be at least two to three times the V_{CAP} . The extra margin is important because some capacitors lose capacitance when operated at their full rated voltages. When selecting a capacitor, be sure to add in their tolerance because of capacitor drift. For example:

- $C_{ST} = 1\mu F$, 20% tolerance; $V_{CAP} = 15V$
- $1\mu F \times 20\% = 0.2\mu F$
- $1\mu F + 0.2\mu F = \underline{1.2\mu F}$

Capacitance drift can also be due to temperature and the dielectrics used. Therefore, the required capacitor value is 1.2 μF or next higher value, and the capacitor voltage rating must be at least 30 volts. It is recommended to go higher in the voltage rating if engineering restraints permit, such as 50V. Temperature requirements for capacitors are application-specific. The designer must know the intended operating temperature when selecting capacitors. The information given above should be applied to other capacitors discussed in this data sheet.

The CPC1580 can deliver 32nC at the rated operating speed and will operate with much larger loads (>4 μF) with slower turn-on and turn-off times.

Note: Care must be taken to minimize any capacitor-to-ground leakage current path between pins 7 and 8 (MOSFET gate current) and between pins 5 and 6. Leakage currents will discharge the storage capacitor and, even though the device is already on, will become a load to the photocurrent, which keeps the gate voltage on. The gate voltage will be reduced if >500nA of leakage is present, therefore the combined impedance from pin 8 to pin 7, pin 5, and pin 6, capacitor current, and MOSFET current must be >20M Ω over the temperature rating of the part.

4.3 Transistor Selection

The CPC1580 charges and discharges an external MOSFET transistor. The selection of the MOSFET is determined by the user to meet the specific power requirements for the load. The CPC1580 output voltage is listed in the specifications, but as mentioned earlier, there must be little or no gate leakage.

Another parameter that plays a significant role in the selection of the transistor is the gate drive voltage available from the part. The CPC1580 uses photovoltaic cells to collect the optical energy generated by the LED; to generate more voltage, the photovoltaic diodes are stacked. The voltage change of the photovoltaic stack reduces with increased temperature. The user must select a transistor that will maintain the load current at the maximum temperature, given the V_{GS} in **Section 1.7**, the CPC1580 Table of Electrical Specifications.

The example circuits shown in **Figure 1** and **Figure 3** use “logic level” MOSFETs for each design to maintain the load described.

4.3.1 Transistor Switching Characteristics

The primary characteristics of the application switching are t_{on} , t_{off} , t_{RISE} , t_{FALL} , and the recovery time of the storage capacitor, t_{CHG} . These parameters are dependent on the MOSFET selection and need to be reviewed in light of the application requirements.

The CPC1580 turns on the MOSFET transistor to the specified V_{GS} after the t_{on} delay. Similarly the t_{off} delay is the amount of time until the LED is turned off and the capacitive load discharges to the level in the CPC1580 specification. For MOSFETs with larger or smaller required gate charge the t_{on} and t_{off} will be proportionately faster and slower, but it is not a linear relationship.

To calculate the nominal rise time of the transistor's drain voltage, V_D :

$$t_{RISE,VD} \approx \frac{V_{LOAD} \cdot C_{RSS}}{I_{G_SINK}} \quad (\text{SECONDS})$$

To calculate the nominal fall time of the transistor's drain voltage, V_D :

$$t_{FALL,VD} \approx \frac{V_{LOAD} \cdot C_{RSS}}{I_{G_SOURCE}} \quad (\text{SECONDS})$$

Where C_{RSS} is the MOSFET gate-drain capacitance (averaged over the switching voltage range) found in the MOSFET data sheet, I_{G_SINK} is the gate sinking current of the CPC1580, and I_{G_SOURCE} is the gate driving ability. The maximum value of t_{RISE} is limited by the CPC1580 unloaded discharge characteristic and should be reviewed in light of the final application component selections if critical.

The value for the charge time, t_{CHG} , is due to external component selection. The storage capacitor charge recovery time (seconds) is computed as:

$$t_{CHG} \approx - (400 + R_{OVP}) \cdot (C_{ST} + C_{OVP}) \cdot \ln \left(\frac{(V_{LOAD} - V_{FINAL}) \cdot C_{ST}}{Q_G} \right)$$

Which reduces to:

$$t_{CHG} \approx - (400 + R_{OVP}) \cdot (C_{ST} + C_{OVP}) \cdot 3$$

R_{OVP} and C_{OVP} are optional over-voltage protection elements that are present in the application circuit diagram (see **Figure 3**).

The term inside the logarithm reflects the discharge and recharge voltage on C_{ST} . For practical circuit component selection, this can be simplified as described above.

Use this information to calculate the maximum switching frequency in **Section 7** below.

Note: *The CPC1580 is ideal to use where remote power is otherwise unavailable. If the LED is also powered remotely, care must be taken to ensure that parasitic transient signals are reliably filtered from the input control signal. Large transient currents will mutually couple energy between cables and a simple R-C filtering of the CPC1580 input may be sufficient to suppress false turn-on.*

Figure 2. CPC1580 AC Application Circuit

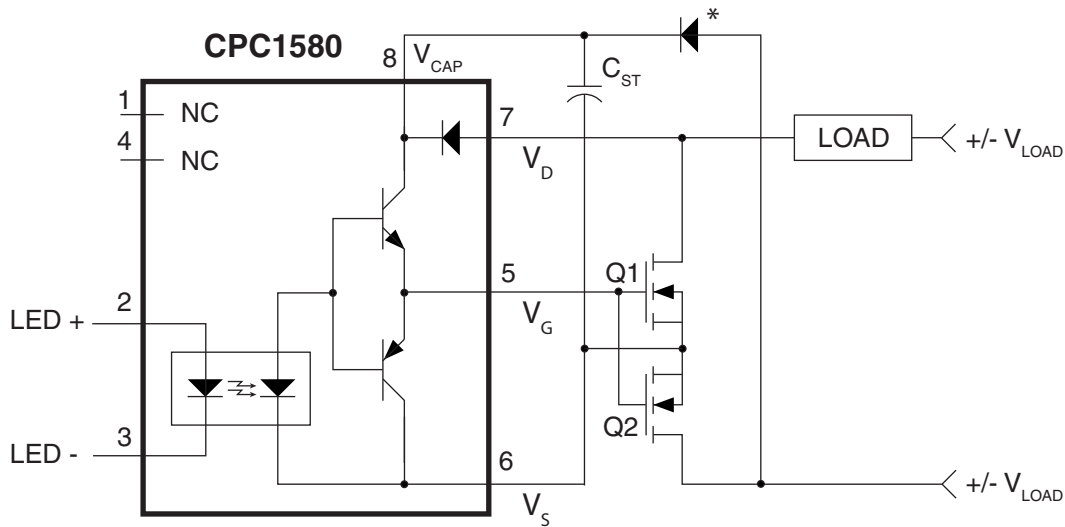

* Minimum Blocking Voltage = 100V

5. CPC1580 Over-Voltage Protection

Over-voltage protection is generally required for the CPC1580 because of parasitic inductance in the load, wires, board traces, and axial leads of protectors. Purely resistive loads or loads with low voltage switching may be able to rely on the transistor to handle any parasitic energy and thereby not require

protection for the CPC1580. For very low inductance loads and traces, over-voltage suppression may be handled with a simple R-C filter consisting of R_{OVP} and C_{OVP} or by use of a free-wheeling diode (see **Figure 3**). For more moderate load inductance, or remote switching of a load (i.e. through a long cable) a voltage suppressor can be used. For heavily inductive loads only a free-wheeling diode, D_{OVP} connected

across the load element is recommended, see **Figure 3**.

The energy not consumed in switching losses must be absorbed by the over-voltage protection element. Most protective devices are designed to withstand certain peak power, in the case of a Transient Voltage Suppressor (TVS); or maximum avalanche energy, in the case of a MOSFET. Understanding the switching losses and load dynamics is absolutely essential.

One simple way to reduce the amount of stored inductive energy is to increase the energy dissipated in the switch. This can be accomplished by adding a larger capacitor in parallel with the gate-drain connection of the MOSFET, however care must be taken so that the rise time and peak current do not exceed the Safe Operating Area (SOA) rating of the transistor.

The consequence of increasing the gate-drain effective capacitance is reduced dV/dt tolerance.

When used in a circuit with an inductive load, precautions must be taken to prevent damage to the circuit from inductively generated voltage spikes. The circuit shown in **Figure 3** includes such protection across the inductive load.

5.1 Other Protection Techniques

Switching loads with higher inductance characteristics requires consideration of other circuit protection techniques, device ratings, or protector types. Of paramount importance is that the designer know the characteristics of the load being switched.

Figure 3. CPC1580 Over-Voltage Protection for Inductive Loads

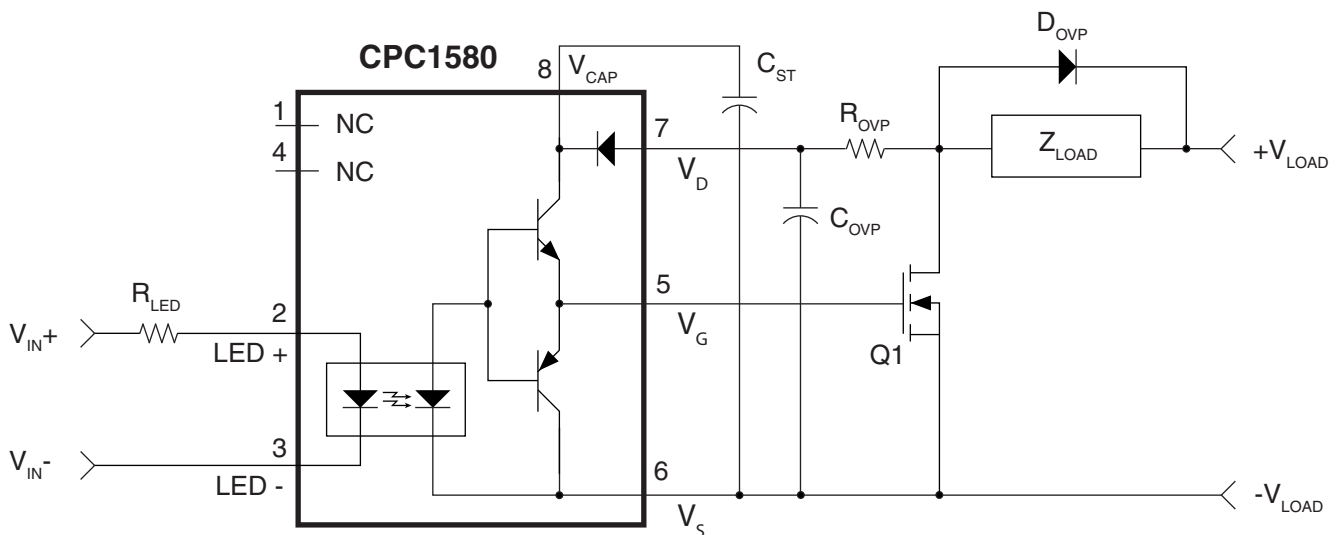

6. Application Switching Losses

During the transition intervals, the application and load components change energy states and, in the process, incur switching losses. The switching losses are manifested as heat in the application circuit and must be addressed by the designer to ensure that no one component exceeds its power rating. The designer must understand the details of the load behavior in order to adequately size and protect the application circuit. There are three general cases to observe: (1) purely resistive loads,

(2) inductive/resistive loads, and (3) loads with significant capacitance. Inductors and capacitors are energy storage elements that require special consideration for switching.

During the switching periods, energy is conserved. Inductors turning off transfer their stored energy to MOSFET switching losses, to the capacitance of the load and application circuit, and to the protector.

During the turn-on interval, the inductor energy is zero, and so the capacitive energy in the load and parasitic elements of the switching application must be

dissipated by the MOSFET, in order for the load to change state.

To calculate the stored inductive energy in Joules:

$$E_L = \frac{1}{2} \cdot L \cdot I_{LOAD}^2$$

6.1 Resistive Load Losses: The Ideal Case

For purely resistive loads, the energy dissipated by changing states occurs primarily in the MOSFET.

The equation describing MOSFET energy dissipation during rise time, in Joules, is:

$$E_{RISE} \geq V_{LOAD}^2 \cdot \frac{C_{RSS}}{I_{G_SINK}} \cdot \frac{I_{LOAD}}{6} = \frac{P_{LOAD}}{6} \cdot t_{RISE}$$

The average power of the MOSFET for any load type in Watts is:

$$P_{AVG} = I_{LOAD}^2 \cdot R_{DSAT} \cdot D + f_{SWITCH} \cdot (E_{RISE} + E_{FALL})$$

Where f_{SWITCH} is the application switching frequency; R_{DSAT} is the MOSFET's on-resistance; D is the switch's operational duty cycle: $D = t_{on}/(t_{on}+t_{off})$; and E_{FALL} is MOSFET energy dissipation during fall time, in Joules.

6.2 Inductive/Resistive Loads

If the load is resistive and inductive, and the inductance doesn't saturate, the load current during turn off, t_{RISE} , in Amps is:

$$I_{LOAD}(t) = \frac{V_{LOAD}}{R_{LOAD}} - \frac{I_{G_SINK}}{L_{LOAD} \cdot C_{RSS}} \cdot \left(\frac{L_{LOAD}}{R_{LOAD}} \right)^2 \cdot \left[\frac{R_{LOAD}}{L_{LOAD}} \cdot t - 1 + e^{-\frac{R_{LOAD}}{L_{LOAD}} \cdot t} \right]$$

and the MOSFET drain voltage during turn off, t_{RISE} , in Volts is:

$$V_{DRAIN}(t) = \frac{I_{G_SINK}}{C_{RSS}} \cdot t$$

The instantaneous power in the MOSFET will be the product of the two equations and the energy will be the integral of the power over time.

6.3 Capacitive Loads

The energy absorbed by the MOSFET for loads that are more capacitive in nature occurs during the MOSFET turn-on as opposed to the turn-off. The energy absorbed by the MOSFET will be a function of the load, the TVS (or other protector), and the MOSFET drain capacitance. The MOSFET energy, E_{FALL} , in Joules is:

$$E_{FALL} = \frac{1}{2} \cdot (C_{TVS} + C_{OSS} + C_{LOAD}) \cdot V_{LOAD}^2$$

C_{OSS} is the MOSFET output capacitance found in the data sheet. As mentioned earlier, the MOSFET switching losses occur at different times, either rising or falling, so loads with a combination of inductance and capacitance can also be calculated by the energy equations described above.

6.4 dV/dt Characteristics

The application circuit shown in **Figure 1** dissipates significant energy caused by large dV/dt events. Fault voltages across the MOSFET will turn it on for the same reason the part turns off slowly. For dV/dt events $> I_{G_SINK}/C_{RSS}$ (from Equation 2) the application circuit will dissipate energy proportional to the C_{RSS} and g_{FS} (forward conductance) of the selected transistor. C_{RSS} is a function of the transistor's on-resistance and current/power capability, so higher load designs are more sensitive.

The CPC1580 provides an internal clamp to protect the gate of the MOSFET from damage in such an event. The part can withstand 100mA for short periods, like dV/dt transients.

7. Design Switching Frequency

The maximum switching frequency is the last design value to be calculated, because the over-voltage protection and the storage capacitor play a significant role in determining the result. Inasmuch as those factors are already determined, the following gives a good approximation for the maximum switching frequency. The maximum switching frequency is a function of the gate charge of the MOSFET, the storage capacitor (C_{ST}), and R_{OVP} . The maximum switching frequency relationship in Hz is:

Where:

$$f_{\text{MAX}} \leq \frac{1}{M} \cdot (t_{\text{on}} + t_{\text{off}} + (t_{\text{RISE,VD}} \mid t_{\text{CHG}}) + t_{\text{FALL,VD}})^{-1}$$

- M=3 (multiplication factor for temperature and process variations)
- t_{on} and t_{off} are CPC1580 data sheet parameters
- $t_{\text{RISE,VD}}$ is the rise time of the drain voltage and t_{CHG} is the charge time of the storage capacitor and the over-voltage protection circuitry as derived in **Section 4.3**: choose the greater of $t_{\text{RISE,VD}}$ or t_{CHG} for the calculation
- $t_{\text{FALL,VD}}$ is the fall time across the transistor

There is no minimum switching frequency since the CPC1580 uses photovoltaic diodes to keep the output charged while LED current flows.

8. Manufacturing Information

8.1 Moisture Sensitivity



All plastic encapsulated semiconductor packages are susceptible to moisture ingress. IXYS Integrated Circuits Division classified all of its plastic encapsulated devices for moisture sensitivity according to the latest version of the joint industry standard, **IPC/JEDEC J-STD-020**, in force at the time of product evaluation. We test all of our products to the maximum conditions set forth in the standard, and guarantee proper operation of our devices when handled according to the limitations and information in that standard as well as to any limitations set forth in the information or standards referenced below.

Failure to adhere to the warnings or limitations as established by the listed specifications could result in reduced product performance, reduction of operable life, and/or reduction of overall reliability.

This product carries a **Moisture Sensitivity Level (MSL) rating** as shown below, and should be handled according to the requirements of the latest version of the joint industry standard **IPC/JEDEC J-STD-033**.

Device	Moisture Sensitivity Level (MSL) Rating
CPC1580	MSL 1

8.2 ESD Sensitivity



This product is **ESD Sensitive**, and should be handled according to the industry standard **JESD-625**.

8.3 Reflow Profile

This product has a maximum body temperature and time rating as shown below. All other guidelines of **J-STD-020** must be observed.

Device	Maximum Temperature x Time
CPC1580	260°C for 30 seconds

8.4 Board Wash

IXYS Integrated Circuits Division recommends the use of no-clean flux formulations. However, board washing to remove flux residue is acceptable. Since IXYS Integrated Circuits Division employs the use of silicone coating as an optical waveguide in many of its optically isolated products, the use of a short drying bake could be necessary if a wash is used after solder reflow processes. Chlorine- or Fluorine-based solvents or fluxes should not be used. Cleaning methods that employ ultrasonic energy should not be used..



8.5 CPC1580P Package

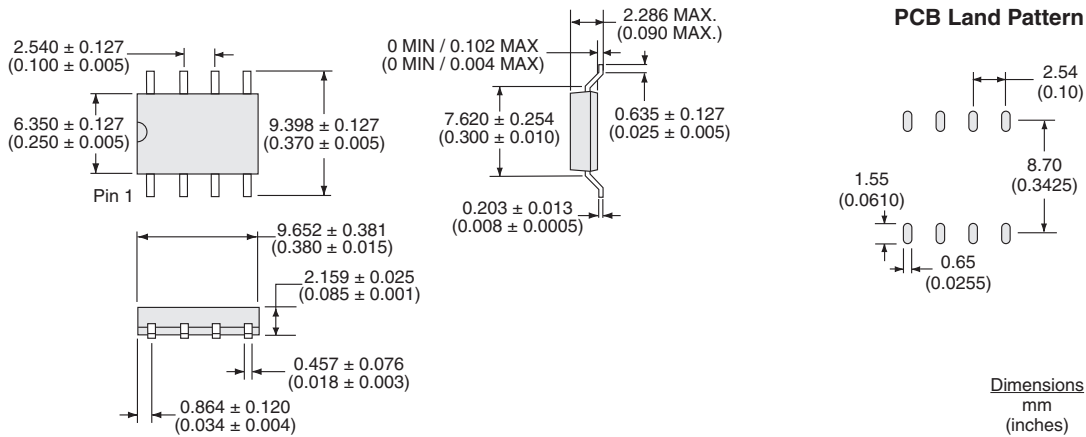

8.6 CPC1580PTR Tape and Reel Specification

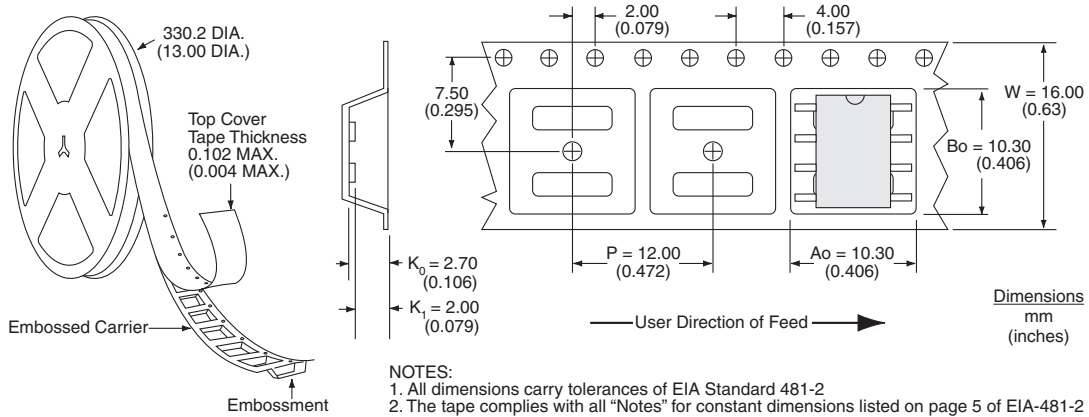

For additional information please visit our website at: www.ixysic.com

IXYS Integrated Circuits Division makes no representations or warranties with respect to the accuracy or completeness of the contents of this publication and reserves the right to make changes to specifications and product descriptions at any time without notice. Neither circuit patent licenses nor indemnity are expressed or implied. Except as set forth in IXYS Integrated Circuits Division's Standard Terms and Conditions of Sale, IXYS Integrated Circuits Division assumes no liability whatsoever, and disclaims any express or implied warranty, relating to its products including, but not limited to, the implied warranty of merchantability, fitness for a particular purpose, or infringement of any intellectual property right.

The products described in this document are not designed, intended, authorized or warranted for use as components in systems intended for surgical implant into the body, or in other applications intended to support or sustain life, or where malfunction of IXYS Integrated Circuits Division's product may result in direct physical harm, injury, or death to a person or severe property or environmental damage. IXYS Integrated Circuits Division reserves the right to discontinue or make changes to its products at any time without notice.

Specification: DS-CPC1580-R01
©Copyright 2013, IXYS Integrated Circuits Division
All rights reserved. Printed in USA.
7/11/2013