



Chipsmall Limited consists of a professional team with an average of over 10 year of expertise in the distribution of electronic components. Based in Hongkong, we have already established firm and mutual-benefit business relationships with customers from,Europe,America and south Asia,supplying obsolete and hard-to-find components to meet their specific needs.

With the principle of “Quality Parts,Customers Priority,Honest Operation,and Considerate Service”,our business mainly focus on the distribution of electronic components. Line cards we deal with include Microchip,ALPS,ROHM,Xilinx,Pulse,ON,Everlight and Freescale. Main products comprise IC,Modules,Potentiometer,IC Socket,Relay,Connector.Our parts cover such applications as commercial,industrial, and automotives areas.

We are looking forward to setting up business relationship with you and hope to provide you with the best service and solution. Let us make a better world for our industry!



Contact us

Tel: +86-755-8981 8866 Fax: +86-755-8427 6832

Email & Skype: info@chipsmall.com Web: www.chipsmall.com

Address: A1208, Overseas Decoration Building, #122 Zhenhua RD., Futian, Shenzhen, China



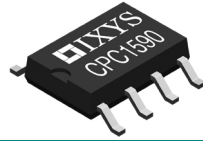

Driver Characteristics

Parameter	Rating	Units
Input Current	2.5	mA
Switching Speed ($I_F=5\text{mA}$, MOS Input Capacitance=4nF)		
$t_{d(on)}$	12	μs
$t_{d(off1)}$ ($V_{GS}=2\text{V}$)	125	
$t_{d(off2)}$ ($V_{GS}=1\text{V}$)	210	

Features

- 3750V_{rms} Input-to-Output Isolation
- Drives External Power MOSFET
- Low LED Current (2.5mA)
- Requires No External Power Supply
- Load Voltages up to 200V
- High Reliability
- Small 8-pin Surface Mount Flatpack Package
- Machine Insertable, Wave Solderable
- Tape and Reel Version Available

Applications

- Industrial Controls
- Instrumentation
- Medical Equipment Isolation
- Electronic Switching
- I/O Subsystems
- Appliances



Description

The CPC1590 is a MOSFET Gate Driver that requires no external power supply: it regulates the input voltage drawn from the load (up to 200V), down to 12.2V for internal use. It is specifically designed for low duty cycle switching applications that drive up to 4nF of gate capacitance.

The CPC1590 accomplishes very fast MOSFET turn-on by supplying stored charge, from an external capacitor, to the MOSFET gate when input control current is applied to the device's LED. After the MOSFET is turned on, photocurrent from the input optocoupler keeps it on for as long as sufficient input control current flows, so there is no low-frequency operating limit. When the MOSFET is turned off, the storage capacitor charges from the device's regulated internal voltage in preparation for the next turn-on.

Because it is provided in a small, 8-pin Flatpack package and requires no separate power supply, the CPC1590 provides a flexible design solution that consumes the least amount of PCB land area.

Approvals

- UL Recognized Component: File E76270

Ordering Information

Part	Description
CPC1590P	8-Pin Flatpack (50/Tube)
CPC1590PTR	8-Pin Flatpack (1000/Reel)

Figure 1. CPC1590 Block Diagram

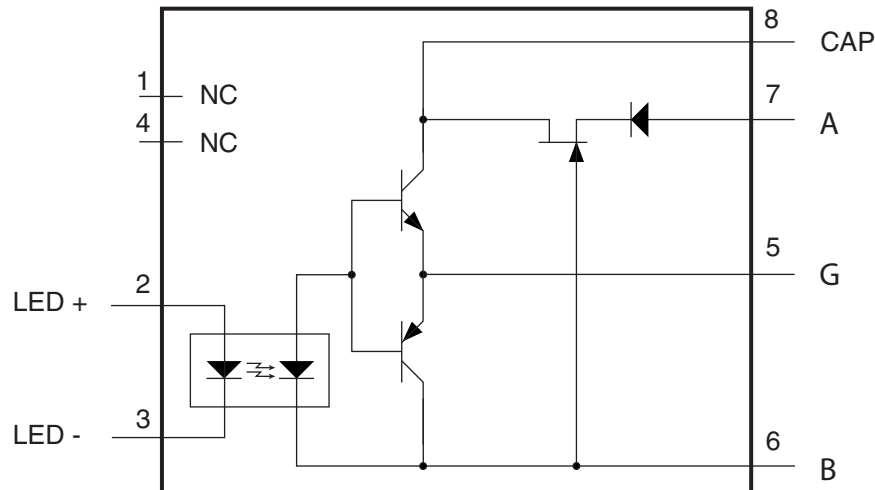

1. Specifications	3
1.1 Package Pinout	3
1.2 Pin Description	3
1.3 Absolute Maximum Ratings	3
1.4 ESD Rating	3
1.5 Recommended Operating Conditions	3
1.6 General Conditions	4
1.7 Electrical Specifications	4
1.8 Performance Data	5
2. Introduction	6
3. Functional Description	6
4. Device Configuration	7
4.1 LED resistor	7
4.2 Storage Capacitor	7
4.3 Transistor Selection	8
5. CPC1590 Used as an AC Switch	8
6. Conclusion	8
7. Manufacturing Information	9
7.1 Moisture Sensitivity	9
7.2 ESD Sensitivity	9
7.3 Reflow Profile	9
7.4 Board Wash	9
7.5 Mechanical Dimensions	10

1. Specifications

1.1 Package Pinout

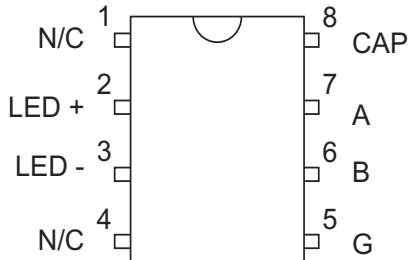

1.2 Pin Description

Pin#	Name	Description
1	-	Not connected
2	LED +	Positive input to LED
3	LED -	Negative input to LED
4	-	Not connected
5	V _G	Output, MOSFET Gate Control
6	V _{L2}	-Load Voltage DC, ±Load Voltage AC
7	V _{L1}	+Load Voltage DC, ±Load Voltage AC
8	V _{CAP}	Storage Capacitor Voltage

1.3 Absolute Maximum Ratings

Parameter	Rating	Units
Blocking Voltage (V _{DS})	200	V _P
Reverse Input Voltage	5	V
Input Control Current	50	mA
Peak (10ms)	1	A
Input Power Dissipation	20	mW
Total Package Dissipation	200	mW
Isolation Voltage (Input to Output)	3750	V _{rms}
Operational Temperature	-40 to +110	°C
Storage Temperature	-40 to +125	°C

Absolute maximum electrical ratings are at 25°C

Absolute maximum ratings are stress ratings. Stresses in excess of these ratings can cause permanent damage to the device. Functional operation of the device at conditions beyond those indicated in the operational sections of this data sheet is not implied.

1.4 ESD Rating

ESD Rating (Human Body Model)
1000 V

1.5 Recommended Operating Conditions

Parameter	Symbol	Min	Max	Units
Load Voltage	V _L	15	200	V
Input Control Current	I _F	2.5	10	mA
Forward Voltage Drop	V _F	1	1.4	V
Operating Temperature	T _A	-40	+110	°C

1.6 General Conditions

Unless otherwise specified, minimum and maximum values are guaranteed by production testing.

Typical values are characteristic of the device at 25°C and are the result of engineering evaluations. They are provided for informational purposes only and are not part of the manufacturing testing requirements.

Unless otherwise noted, all electrical specifications are listed for $T_A=25^\circ\text{C}$.

1.7 Electrical Specifications

Parameter	Conditions	Symbol	Min	Typ	Max	Units
Load Side Characteristics						
Gate Voltage	$I_F=2.5\text{mA}$	V_{GS}	7.0	7.3	12	V
	$I_F=5\text{mA}$		7.5	8.0		
	$I_F=10\text{mA}$			8.4		
	$I_F=2.5\text{mA}$ $-40^\circ\text{C}<T_A<110^\circ\text{C}$		4.2	-	14.4	
Capacitor Voltage	$10\text{V}<V_{DS}<200\text{V}$	V_{CAP}	10	12.2	16	V
Gate Drive Capability	$I_F=2.5\text{mA}, V_{GS}=0\text{V}, V_{CAP}=15\text{V}$	I_{G_source}	2	3.3	7	mA
	$I_F=0\text{mA}, V_{GS}=8\text{V}, V_{CAP}=8\text{V}$	I_{G_sink}	4.0	9.0	14	
	$I_F=0\text{mA}, V_{GS}=4\text{V}, V_{CAP}=4\text{V}$		1.5	3.3	6	
	$I_F=0\text{mA}, V_{GS}=2\text{V}, V_{CAP}=2\text{V}$		0.5	1.2	2	
Turn-On Delay	$V_{DS}=48\text{V}, V_{GS}=4\text{V}, C_{VG}=4\text{nF}$	t_{on}	1			μs
	$I_F=2.5\text{mA}$			40	140	
	$I_F=5\text{mA}$			12	40	
	$I_F=10\text{mA}$			5	20	
Turn-Off Delay	$V_{DS}=48\text{V}, V_{GS}=2\text{V}, C_{VG}=4\text{nF}$	t_{off1}	40			μs
	$I_F=2.5\text{mA}$			110	400	
	$I_F=5\text{mA}$			125		
	$I_F=10\text{mA}$			130		
	$V_{DS}=48\text{V}, V_{GS}=1\text{V}, C_{VG}=4\text{nF}$	t_{off2}	40			μs
	$I_F=2.5\text{mA}$			200	600	
	$I_F=5\text{mA}$			210		
	$I_F=10\text{mA}$			220		
Off-State Leakage Current	$V_{DS}=200\text{V}$	I_{DS}	-	-	1	μA
LED Characteristics						
Forward Voltage Drop	$I_F=5\text{mA}$	V_F	1	1.27	1.4	V
Input Dropout Current	$V_{GS}=1\text{V}$	I_F	0.2	0.75	1	mA
Reverse Bias Leakage Current	$V_R=5\text{V}$	I_R	-	-	10	μA
Common Characteristics						
Input to Output Capacitance	-	$C_{I/O}$	-	3	-	pF

1.8 Performance Data

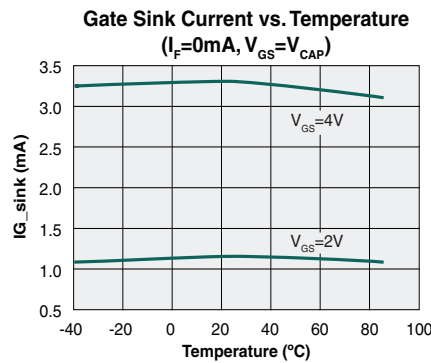
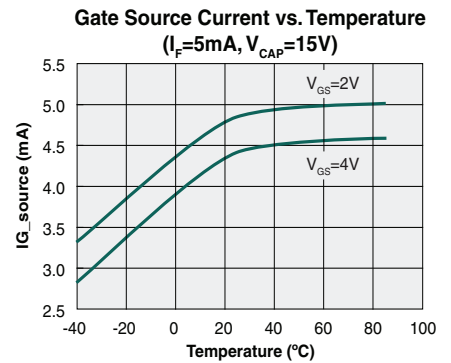
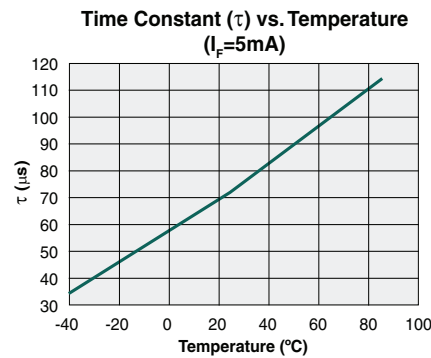
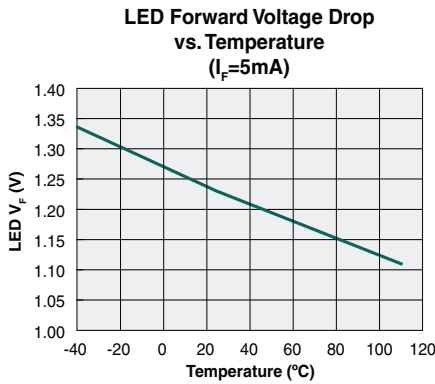
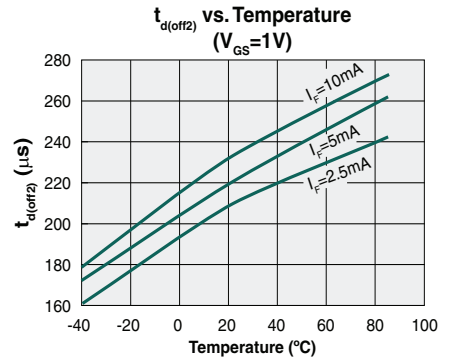
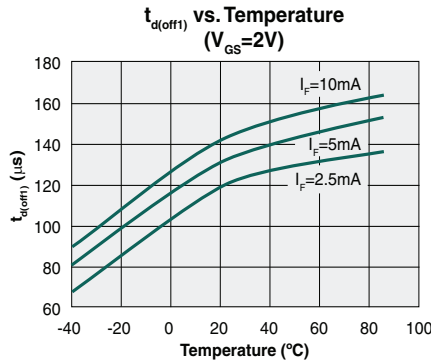
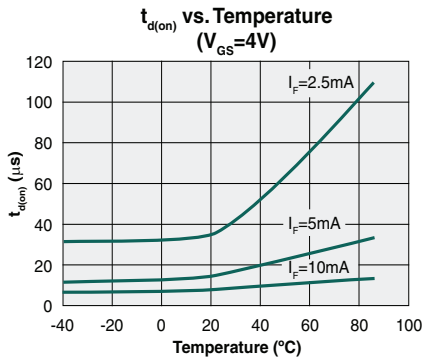

The Performance data shown in the graphs above is typical of device performance. For guaranteed parameters not indicated in the written specifications, please contact our application department.

2. Introduction

The CPC1590 is a MOSFET Gate Driver that requires no external power supply. It can regulate an input voltage, up to 200V, down to 12.2V for internal use. It is specifically designed for low-duty-cycle switching frequencies that drive 4nF of gate capacitance.

3. Functional Description

The CPC1590 is used in conjunction with a single MOSFET transistor for remote switching of DC loads (**Figure 2**), and two MOSFETs and a diode for remote switching of low-frequency AC loads (**Figure 3**) where isolated power is unavailable.

The device uses external components, most notably a charge storage capacitor, to satisfy design switching and over-voltage protection requirements. Because of this design flexibility, the designer may choose a great number of MOSFETs for use in a wide variety of applications. The designer simply needs to know the MOSFET total gate charge (Q_G), and with this information a capacitor can be chosen. The capacitance of the storage capacitor should be greater than, or equal to, $Q_G/0.5V$.

The CPC1590 has two states of operation:
 (1) sufficient input control current is flowing, the LED is turned on, and the gate current is being applied. The light from the LED is being reflected onto the photovoltaic, which then produces a photocurrent that

turns on the NPN bipolar transistor and provides the charge ($I \times t = Q$), or the gate current that is being applied to turn on the MOSFET. (2) Sufficient input control current is not flowing, the LED is turned off, and gate current is not flowing. The LED is off because $V_F \ll$ the minimum forward voltage required, and not enough current is being applied. This turns on the PNP bipolar transistor, providing a path for gate current to discharge to V_{L2} .

When V_{LOAD} is first applied, the external storage capacitor begins to charge. The charge is sent through a bootstrap diode to prevent the charge from escaping and discharging through a turned-on MOSFET. The J-FET then regulates the voltage between 10V and 16V. The input control current is applied, then the charge is transferred from the storage capacitor through the NPN bipolar transistor, along with the charge from the photovoltaic, to the MOSFET gate to accomplish a rapid turn-on. After the capacitor has discharged and the MOSFET has turned on, the photocurrent from the input optocoupler continues to flow into the gate to keep the MOSFET turned on.

When the input control current is removed, the gate current stops flowing and the PNP bipolar transistor is on and is discharging the MOSFET gate. The MOSFET is now off. At this point the capacitor begins to recharge for the next turn on cycle.

The circuit below does not include over-voltage protection.

Figure 2. CPC1590 DC Application Circuit

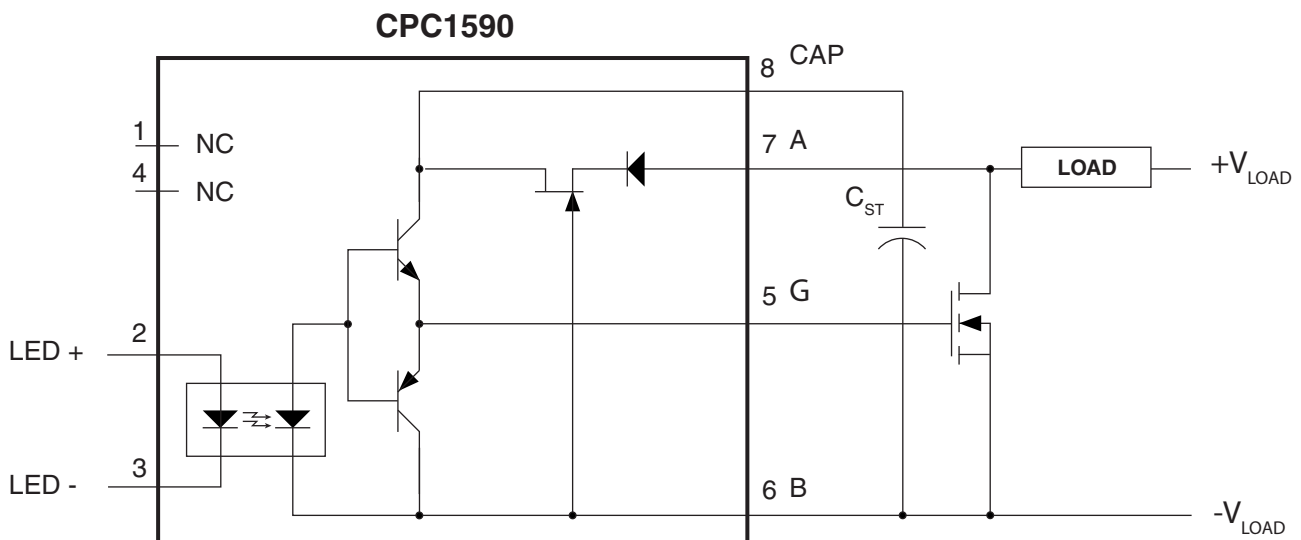

4. Device Configuration

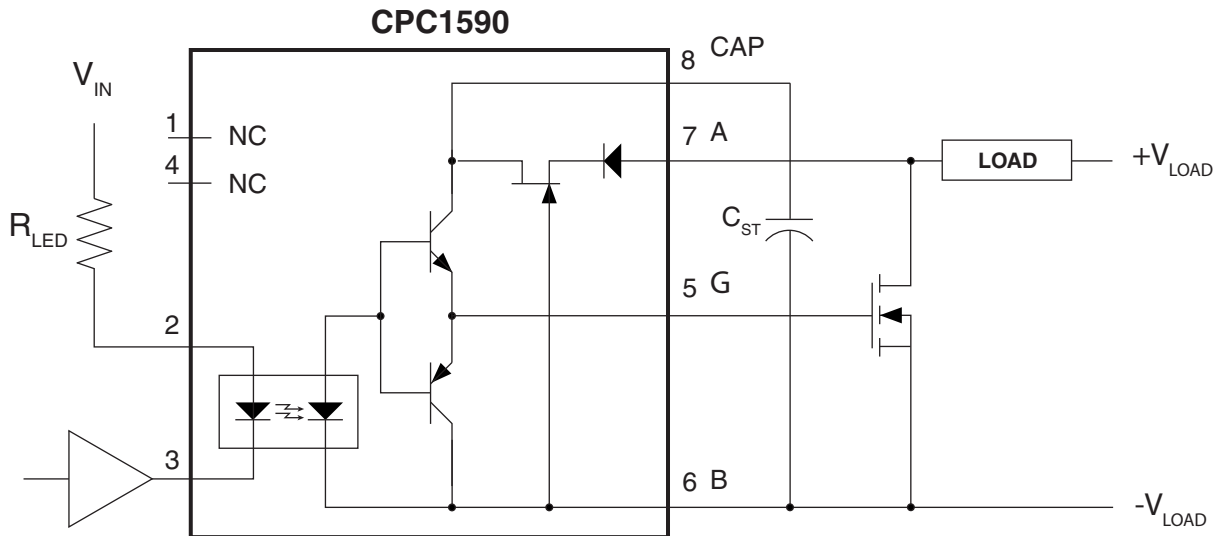

4.1 LED resistor

The input resistor is required to limit LED current to a value set by Recommended Operating Conditions in “Recommended Operating Conditions” on page 3. In some cases, higher LED operating current would improve driver speed; however, this higher current could also reduce LED lifespan, which would cause reliability issues.

The general equation used to calculate the resistor value is:

$$R_{LED} = \frac{V_{IN} - (V_F + V_{OL})}{I_F}$$

- I_F = Input Control Current
- V_{OL} = Low-level output of the driving logic gate or the collector-emitter voltage of the driving logic transistor. (This parameter is provided in the manufacturer’s data sheet.)
- V_{IN} = Input Power Source
- V_F = Forward Voltage Drop of LED
- R_{LED} = Input Resistor

When calculating the resistor value, the designer should take into consideration power-supply variations, which can range about $\pm 10\%$, temperature variations from -40°C to $+85^\circ\text{C}$, LED forward voltage drop over the temperature range, and the resistor’s tolerance and temperature stability rating.

When the LED resistor value is selected by the above formula, the R_{LED} power dissipation, P_D , can be obtained from the following equation:

$$P_D = I_F^2 \cdot R_{LED}$$

With power dissipation calculated, it is now possible to select an appropriate resistor size that can be used in the particular application circuit. It is recommended that a resistor with at least twice the calculated power rating should be selected.

4.2 Storage Capacitor

The storage capacitor (C_{ST}) enables the gate driver to turn on a power MOSFET faster by delivering a reservoir of charge to the gate. Selection of the storage capacitor is given by the following equation:

$$C_{ST} \geq Q_G / 0.5V$$

This equation shows that the storage capacitor needs to deliver enough charge to the gate while only dropping 0.5V. The CPC1590 can deliver 32nC of charge at rated operating speed, and will operate with much larger loads, $>4\text{nF}$, with slower turn-on and turn-off times.

The CPC1590 has an internal J-FET, which is used to regulate the voltage applied to the storage capacitor. The voltage applied to the storage capacitor will be

between 10V and 16V. The capacitor's voltage rating should be two to three times this range.

The designer should select the storage capacitor based on the particular application requirements. If the final product requires operating at a higher ambient temperature range of -40°C to $+110^{\circ}\text{C}$, then it is better to select COG/NPO capacitors in order to meet minimum capacitance requirements.

4.3 Transistor Selection

The CPC1590 charges and discharges an external MOSFET transistor. The selection of the MOSFET is determined by the user to meet the specific power

requirements for the load. The CPC1590 output voltage is listed in the specification, but, as mentioned earlier, there must be little or no gate leakage.

Another parameter that plays a significant role in the selection of the transistor is the gate drive voltage available from the part. The CPC1590 uses photovoltaic cells to collect the optical energy generated by the internal LED; to generate more voltage, the photovoltaic diodes are stacked. As such, the voltage of the photovoltaic stack reduces with increased temperature. The user must select a transistor that will maintain the load current at the maximum temperature, given the V_{GS} in the CPC1590 specifications.

5. CPC1590 Used as an AC Switch

The CPC1590 can be used in other configurations. One typical configuration is shown in **Figure 3**, which is called an AC Switch. This simply means that either terminal can be positive or negative. This configuration requires a second MOSFET (Q2) and two rectifying diodes (D1 and D2).

The design considerations are identical for this application. Diodes D1 and D2 must have voltage ratings greater than the breakdown voltage of the MOSFETs.

Figure 3. Application Circuit for Using the CPC1590 as an AC Switch

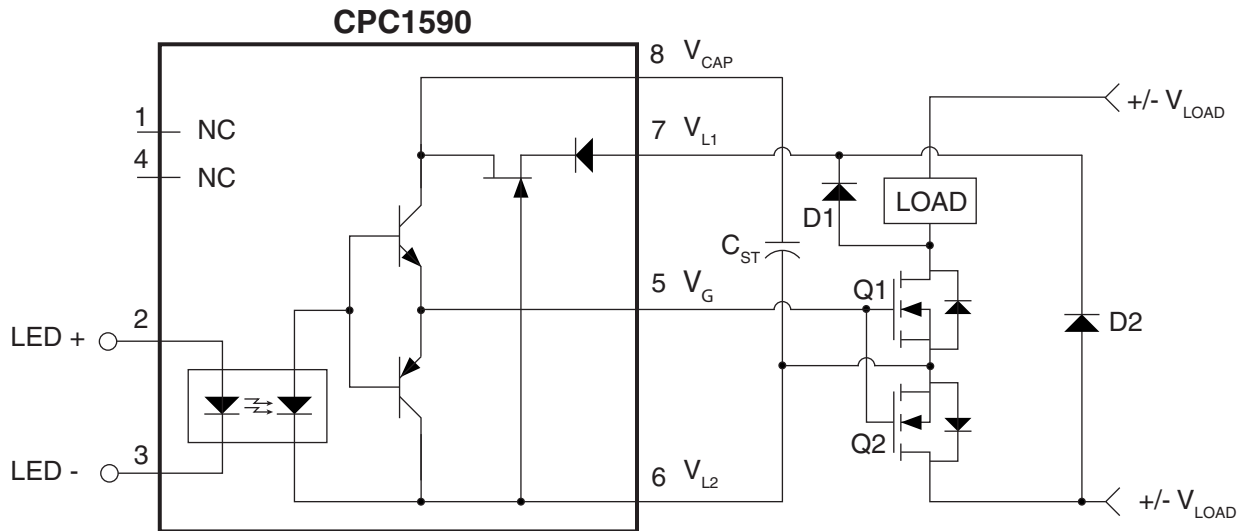

6. Conclusion

See IXYS Integrated Circuits Division's Application Note, AN-202, for a thorough discussion, and for examples of device usage, component selection, and over-voltage protection circuitry.

7. Manufacturing Information

7.1 Moisture Sensitivity



All plastic encapsulated semiconductor packages are susceptible to moisture ingress. IXYS Integrated Circuits Division classified all of its plastic encapsulated devices for moisture sensitivity according to the latest version of the joint industry standard, **IPC/JEDEC J-STD-020**, in force at the time of product evaluation. We test all of our products to the maximum conditions set forth in the standard, and guarantee proper operation of our devices when handled according to the limitations and information in that standard as well as to any limitations set forth in the information or standards referenced below.

Failure to adhere to the warnings or limitations as established by the listed specifications could result in reduced product performance, reduction of operable life, and/or reduction of overall reliability.

This product carries a **Moisture Sensitivity Level (MSL) rating** as shown below, and should be handled according to the requirements of the latest version of the joint industry standard **IPC/JEDEC J-STD-033**.

Device	Moisture Sensitivity Level (MSL) Rating
CPC1590P	MSL 1

7.2 ESD Sensitivity



This product is **ESD Sensitive**, and should be handled according to the industry standard **JESD-625**.

7.3 Reflow Profile

This product has a maximum body temperature and time rating as shown below. All other guidelines of **J-STD-020** must be observed.

Device	Maximum Temperature x Time
CPC1590P	260°C for 30 seconds

7.4 Board Wash

IXYS Integrated Circuits Division recommends the use of no-clean flux formulations. However, board washing to remove flux residue is acceptable. Since IXYS Integrated Circuits Division employs the use of silicone coating as an optical waveguide in many of its optically isolated products, the use of a short drying bake may be necessary if a wash is used after solder reflow processes. Chlorine-based or Fluorine-based solvents or fluxes should not be used. Cleaning methods that employ ultrasonic energy should not be used.



7.5 Mechanical Dimensions

7.5.1 CPC1590P 8-Pin Flatpack Package

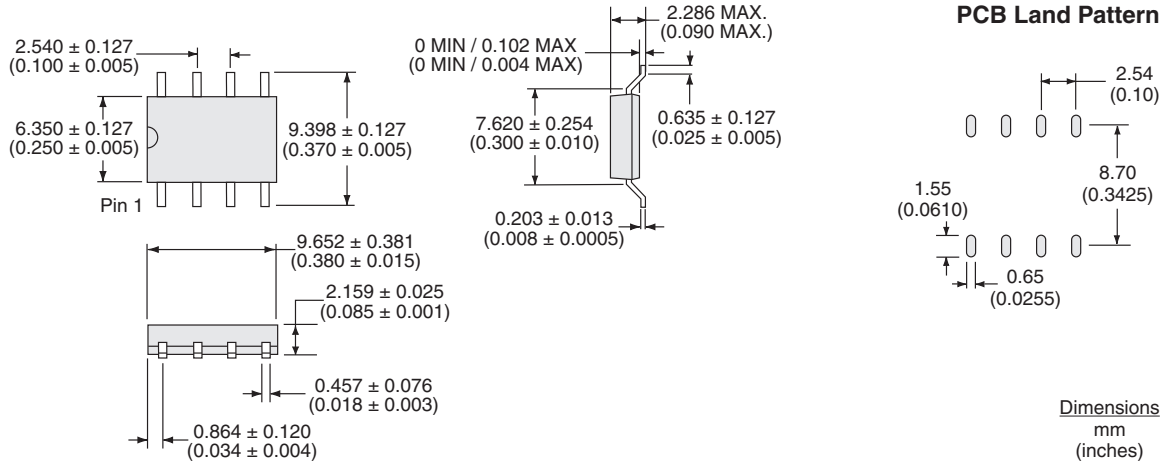

7.5.2 CPC1590PTR Tape & Reel

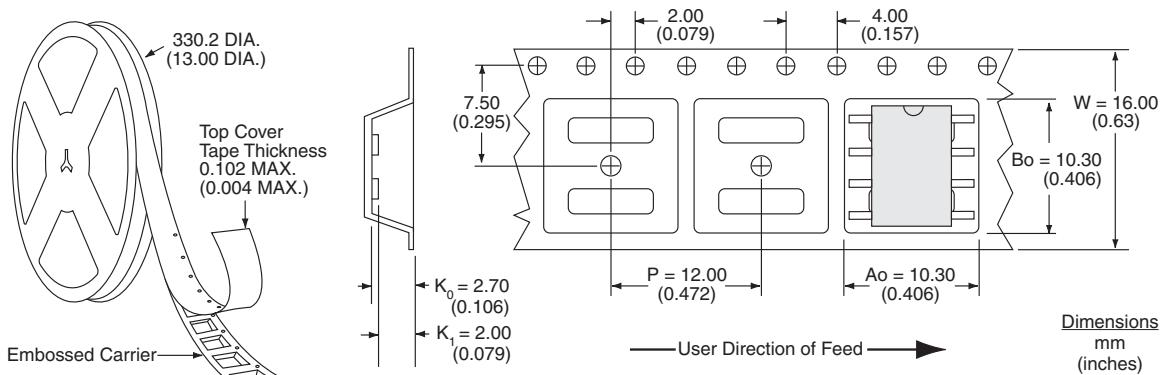

- NOTES:
 1. All dimensions carry tolerances of EIA Standard 481-2
 2. The tape complies with all "Notes" for constant dimensions listed on page 5 of EIA-481-2

For additional information please visit www.ixysic.com

IXYS Integrated Circuits Division makes no representations or warranties with respect to the accuracy or completeness of the contents of this publication and reserves the right to make changes to specifications and product descriptions at any time without notice. Neither circuit patent licenses or indemnity are expressed or implied. Except as set forth in IXYS Integrated Circuits Division's Standard Terms and Conditions of Sale, IXYS Integrated Circuits Division assumes no liability whatsoever, and disclaims any express or implied warranty relating to its products, including, but not limited to, the implied warranty of merchantability, fitness for a particular purpose, or infringement of any intellectual property right.

The products described in this document are not designed, intended, authorized, or warranted for use as components in systems intended for surgical implant into the body, or in other applications intended to support or sustain life, or where malfunction of IXYS Integrated Circuits Division's product may result in direct physical harm, injury, or death to a person or severe property or environmental damage. IXYS Integrated Circuits Division reserves the right to discontinue or make changes to its products at any time without notice.

Specification: DS-CPC1590-R01
 ©Copyright 2013, IXYS Integrated Circuits Division
 All rights reserved. Printed in USA.
 7/11/2013