



Chipsmall Limited consists of a professional team with an average of over 10 year of expertise in the distribution of electronic components. Based in Hongkong, we have already established firm and mutual-benefit business relationships with customers from,Europe,America and south Asia,supplying obsolete and hard-to-find components to meet their specific needs.

With the principle of “Quality Parts,Customers Priority,Honest Operation,and Considerate Service”,our business mainly focus on the distribution of electronic components. Line cards we deal with include Microchip,ALPS,ROHM,Xilinx,Pulse,ON,Everlight and Freescale. Main products comprise IC,Modules,Potentiometer,IC Socket,Relay,Connector.Our parts cover such applications as commercial,industrial, and automotives areas.

We are looking forward to setting up business relationship with you and hope to provide you with the best service and solution. Let us make a better world for our industry!



Contact us

Tel: +86-755-8981 8866 Fax: +86-755-8427 6832

Email & Skype: info@chipsmall.com Web: www.chipsmall.com

Address: A1208, Overseas Decoration Building, #122 Zhenhua RD., Futian, Shenzhen, China





Features

- Processed with BCDMOS on SOI (Silicon on Insulator)
- Flexible High Voltage Supplies up to $V_{PP}-V_{NN}=200V$
- Internal Output Bleeder Resistors
- DC to 10MHz Analog Signal Frequency
- -60dB Minimum Output-Off Isolation at 5MHz
- Low Quiescent Power Dissipation ($< 1\mu A$ Typical)
- Output Switch On-Resistance Typically 20Ω
- TTL I/Os for 3.3V Interface
- Surface Mount Package

Applications

- Ultrasound Imaging
- Printers
- Industrial Controls and Measurement
- Piezoelectric Transducer Drivers

Figure 1. Block Diagram

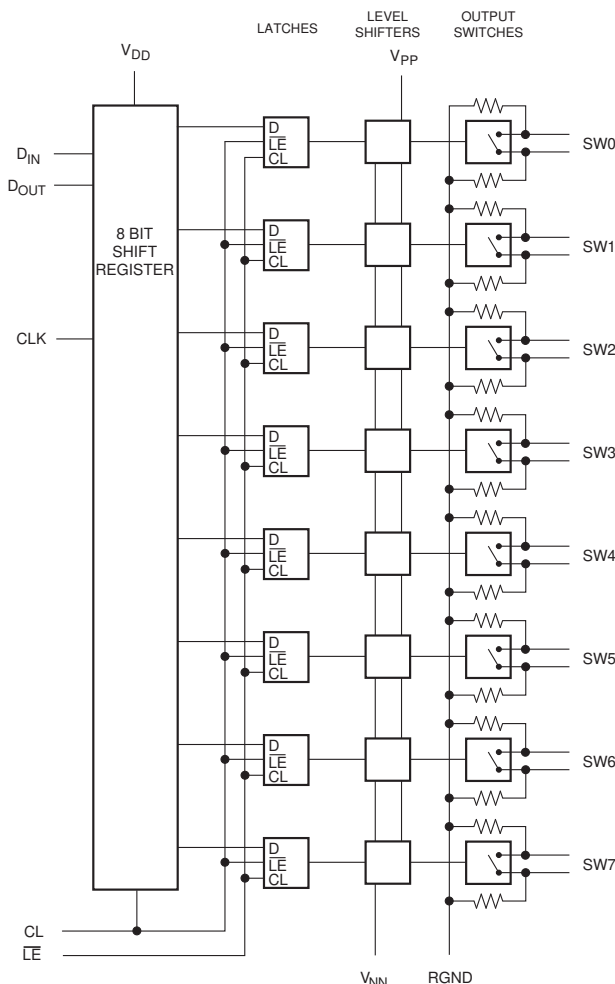

Description

The CPC7232 is a low charge injection 8-channel high-voltage analog switch integrated circuit (IC) for use in applications requiring high voltage switching. Bleeder resistors are incorporated into both terminals of each output switch. Control of the high voltage switching is via low voltage TTL logic level compatible inputs for direct connectivity to the system controller.

Switch manipulation is managed by an 8-bit serial to parallel shift register whose outputs are buffered and stored by an 8-bit transparent latch. Level shifters buffer the latch outputs and operate the high voltage switches.

Because the CPC7232 is capable of switching high load voltages and has a flexible load voltage range, e.g. V_{PP}/V_{NN} : +40V/160V or +100V/100V, it is well suited for many medical and industrial applications such as medical ultrasound imaging, printers, and industrial measurement equipment. The bleeder resistors enable the discharge of capacitive loads, such as piezoelectric transducers, connected to the output switches of the CPC7232.

Construction of the high voltage switches using IXYS Integrated Circuits Division's reliable BCDMOS process technology on SOI (Silicon On Insulator) allow the switches to be organized as solid state switches with direct gate drive.

Ordering Information

Part Number	Description
CPC7232W	28-Lead PLCC in Tubes (37/Tube)
CPC7232WTR	28-Lead PLCC Tape & Reel (500/Reel)
CPC7232K	48-Lead LQFP in Trays (250/Tray)
CPC7232KTR	48-Lead LQFP Tape & Reel (2000/Reel)



1. Specifications	3
1.1 Package Pinout, PLCC-28	3
1.2 Pin Description	3
1.3 Package Pinout, LQFP-48	4
1.4 Pin Description	4
1.5 Absolute Maximum Ratings	5
1.6 Operating Conditions	5
1.7 Electrical Characteristics	6
2. Functional Description	9
2.1 Truth Table	10
2.2 Logic Timing Waveforms	11
3. Manufacturing Information	12
3.1 Moisture Sensitivity	12
3.2 ESD Sensitivity	12
3.3 Soldering Profile	12
3.4 Board Wash	12
3.5 Mechanical Dimensions	13
3.5.1 CPC7232W 28-Pin PLCC Package	13
3.5.2 CPC7232K 48-Pin LQFP Package	13
3.6 Tape and Reel Specifications	14
3.6.1 CPC7232WTR PLCC-28 Tape & Reel	14
3.6.2 CPC7232KTR LQFP-48 Tape & Reel	14

1. Specifications

1.1 Package Pinout, PLCC-28

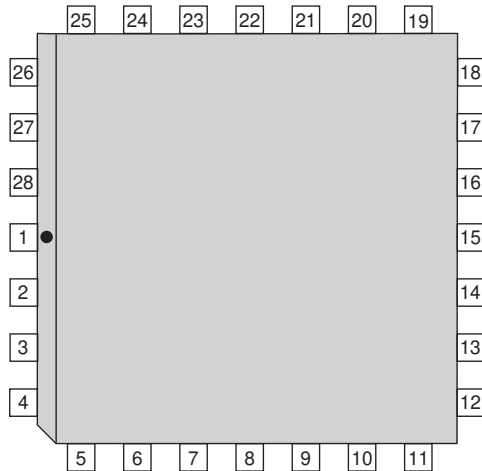

1.2 Pin Description

Pin	Name	Description
1	SW3	SW3 Output
2	SW3	SW3 Output
3	SW2	SW2 Output
4	SW2	SW2 Output
5	SW1	SW1 Output
6	SW1	SW1 Output
7	SW0	SW0 Output
8	SW0	SW0 Output
9	N/C	No connection
10	V _{PP}	Switch positive high voltage supply
11	R _{GND}	Ground for bleed resistors
12	V _{NN}	Switch negative high voltage supply
13	GND	Ground
14	V _{DD}	Logic positive voltage supply
15	N/C	No connection
16	D _{IN}	Serial data input
17	CLK	Clock input, positive edge trigger
18	\overline{LE}	Latch enable, active low
19	CL	Latch clear, active high clears latches and opens switches
20	D _{OUT}	Serial data output
21	SW7	SW7 Output
22	SW7	SW7 Output
23	SW6	SW6 Output
24	SW6	SW6 Output
25	SW5	SW5 Output
26	SW5	SW5 Output
27	SW4	SW4 Output
28	SW4	SW4 Output

1.3 Package Pinout, LQFP-48

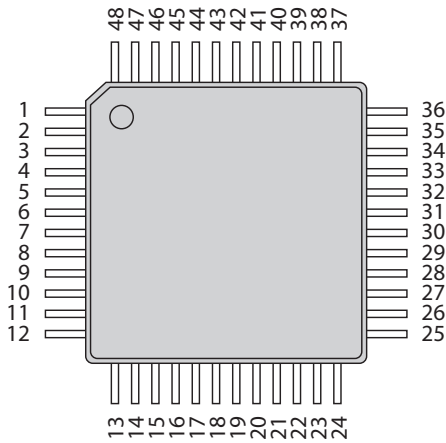

1.4 Pin Description

Pin	Name	Description
1	SW5	SW5 Output
2	N/C	No connection
3	SW4	SW4 Output
4	N/C	No connection
5	SW4	SW4 Output
6	N/C	No connection
7	N/C	No connection
8	SW3	SW3 Output
9	N/C	No connection
10	SW3	SW3 Output
11	N/C	No connection
12	SW2	SW2 Output
13	N/C	No connection
14	SW2	SW2 Output
15	N/C	No connection
16	SW1	SW1 Output
17	N/C	No connection
18	SW1	SW1 Output
19	N/C	No connection
20	SW0	SW0 Output
21	N/C	No connection
22	SW0	SW0 Output
23	N/C	No connection
24	V _{PP}	Switch positive high voltage supply
25	V _{NN}	Switch negative high voltage supply
26	N/C	No connection
27	R _{GND}	Ground for bleed resistors
28	GND	Ground
29	V _{DD}	Logic positive supply voltage
30	N/C	No connection
31	N/C	No connection
32	N/C	No connection
33	D _{IN}	Serial data input
34	CLK	Clock input, positive edge trigger
35	LE	Latch enable, active low
36	CL	Latch clear, active high clears latches and opens switches
37	D _{OUT}	Serial data output
38	N/C	No connection
39	SW7	SW7 Output
40	N/C	No connection
41	SW7	SW7 Output
42	N/C	No connection
43	SW6	SW6 Output
44	N/C	No connection
45	SW6	SW6 Output
46	N/C	No connection
47	SW5	SW5 Output
48	N/C	No connection

1.5 Absolute Maximum Ratings

Parameter	Min	Max	Units
V _{DD} Logic Power Supply Voltage	-0.5	6	V
V _{PP} - V _{NN} Supply Voltage	-	220	V
V _{PP} Positive High Voltage Supply	-0.5	V _{NN} +200	V
V _{NN} Negative High Voltage Supply	-0.5	V _{PP} -200	V
Logic input voltages	-0.5	V _{DD} +0.3	V
Analog signal range	V _{NN}	V _{PP}	V
Peak analog signal current per channel	-	1	A
Power dissipation			
28-Lead PLCC	-	2.5	W
48-Lead LQFP	-	2.3	
Thermal Resistance, Junction to Ambient			°C/W
28-Lead PLCC	-	50	
48-Lead LQFP	-	53	
Storage temperature	-60	+150	°C

Absolute maximum electrical ratings are at 25°C.

Absolute Maximum Ratings are stress ratings. Stresses in excess of these ratings can cause permanent damage to the device. Functional operation of the device at conditions beyond those indicated in the operational sections of this data sheet is not implied.

1.6 Operating Conditions

Parameter	Symbol	Value
Logic power supply voltage ^{1,3}	V _{DD}	4.5V to 6V
Positive high voltage supply ^{1,3}	V _{PP}	40V to V _{NN} + 200V
Negative high voltage supply ^{1,3}	V _{NN}	-40V to -160V
Analog signal voltage, peak-to-peak ²	V _{SW}	V _{NN} +10V to V _{PP} -10V
Operating temperature	T _A	0°C to 70°C

¹ Power up/down sequence is arbitrary except that GND must be powered-up first and powered-down last.

² V_{SW} must be V_{NN} ≤ V_{SW} ≤ V_{PP} or floating during power up/down transition.

³ Rise and fall times of power supplies, V_{DD}, V_{PP}, and V_{NN}, should not be less than 1ms.

1.7 Electrical Characteristics

1.7.1 Switch Characteristics (over recommended operating conditions unless otherwise noted)

Parameter	Symbol	Test Conditions	0°C		+25°C			+70°C		Units
			min	max	min	typ	max	min	max	
Small signal switch on-resistance	R _{ONS}	V _{PP} =40V, V _{NN} =-160V, I _{SW} =5mA	-	30	-	21	38	-	48	Ω
		V _{PP} =40V, V _{NN} =-160V, I _{SW} =200mA	-	25	-	-	27	-	32	
		V _{PP} =100V, V _{NN} =-100V, I _{SW} =5mA	-	25	-	21	27	-	30	
		V _{PP} =100V, V _{NN} =-100V, I _{SW} =200mA	-	18	-	16	24	-	27	
		V _{PP} =160V, V _{NN} =-40V, I _{SW} =5mA	-	23	-	21	25	-	30	
		V _{PP} =160V, V _{NN} =-40V, I _{SW} =200mA	-	22	-	-	25	-	27	
Small signal switch on-resistance matching	ΔR _{ONS}	I _{SW} =5mA, V _{PP} =100V, V _{NN} =-100V	-	20	-	4	20	-	20	%
Large signal switch on-resistance	R _{ONL}	V _{SW} =V _{PP} -10V, I _{SW} =0.8A	-	-	-	16	-	-	-	Ω
Output bleed resistors	R _{INT}	Output switch to R _{GND} , I _{RINT} =0.5mA	-	-	20	28	50	-	-	kΩ
Switch off leakage per switch	I _{SOL}	V _{SW} =V _{PP} -10V and V _{NN} +10V	-	5	-	0.4	10	-	15	μA
DC offset, switch off	-	R _L =100kΩ	-	100	-	0.2	100	-	100	mV
DC offset, switch on	-	R _L =100kΩ	-	100	-	0.2	100	-	100	
Switch output peak current	-	V _{SW} duty cycle = 0.1%	-	-	-	-	0.8	-	-	A
Output switch frequency	f _{SW}	Duty cycle = 50%	-	-	-	-	50	-	-	kHz
Maximum V _{SW} slew rate	dV/dt	V _{PP} =160V, V _{NN} =-40V	-	20	-	-	20	-	20	V/ns
		V _{PP} =100V, V _{NN} =-100V								
		V _{PP} =40V, V _{NN} =-160V								
Off isolation	K _O	f=5MHz, 1kΩ/15pF load	-30	-	-30	-	-	-30	-	dB
		f=5MHz, 50Ω load	-58	-	-58	-	-	-58	-	
Switch crosstalk	K _{CR}	f=5MHz, 50Ω load	-60	-	-60	-	-	-60	-	dB
Output switch isolation diode current	I _{ID}	300ns pulse width, 2.0% duty cycle	-	300	-	-	300	-	300	mA
Off capacitance, SW to GND	C _{SG(OFF)}	V _{SW} =0V, 1MHz	5	17	5	-	25	5	20	pF
On capacitance, SW to GND	C _{SG(ON)}	V _{SW} =0V, 1MHz	25	40	20	-	40	25	50	
Output voltage spike	+V _{SPK}	V _{PP} =40V, V _{NN} =-160V, R _L =50Ω	-	-	-	37	150	-	-	mV
	-V _{SPK}									
	+V _{SPK}	V _{PP} =100V, V _{NN} =-100V, R _L =50Ω				35				
	-V _{SPK}					80				
	+V _{SPK}	V _{PP} =160V, V _{NN} =-40V, R _L =50Ω				46				
	-V _{SPK}					72				
Charge injection	Q	V _{PP} =100V, V _{NN} =-100V, V _{SW} =0V	-	-	-	880	-	-	-	pC

1.7.2 Logic DC Characteristics (over recommended operating conditions unless otherwise noted)

Parameter	Symbol	Test Conditions	0°C		+25°C			+70°C		Units
			min	max	min	typ	max	min	max	
D _{OUT} source capability	V _{OH}	I _{OUT} = -400μA	-	-	V _{DD} -0.7	V _{DD} -0.1	-	-	-	V
D _{OUT} sink capability	V _{OL}	I _{OUT} = +400μA	-	-	-	0.04	0.7	-	-	
Logic input capacitance	C _{IN}	-	-	10	-	-	10	-	10	pF
Logic input high	V _{IH}	4.75V < V _{DD} < 5.25V	2	-	2	-	-	2	-	V
Logic input low	V _{IL}	4.75V < V _{DD} < 5.25V	-	0.8	-	-	0.8	-	0.8	

1.7.3 Logic Timing Characteristics (over recommended operating conditions unless otherwise noted)

Parameter	Symbol	Test Conditions	0°C		+25°C			70°C		Units
			min	max	min	typ	max	min	max	
Setup time before \overline{LE} rises	t _{SD}	-	150	-	150	-	-	150	-	ns
Time width of \overline{LE}	t _{WLE}	-	150	-	150	-	-	150	-	
Clock delay time to Data Out	t _{DO}	-	-	150	-	62	150	-	150	
Time width of CL	t _{WCL}	-	150	-	150	-	-	150	-	
Setup time, data to clock	t _{SU}	-	15	-	15	8	-	20	-	
Hold time, data from clock	t _H	-	35	-	35	-	-	35	-	
Clock frequency	f _{CLK}	50% duty cycle, f _{DATA} =f _{CLK} /2	-	5	-	-	5	-	5	MHz
Clock rise and fall times	t _R , t _F	-	-	50	-	-	50	-	50	ns
Turn-on time	t _{ON}	V _{SW} =V _{PP} -10V, RL=10kΩ	-	5	-	2	5	-	5	μs
Turn-off time	t _{OFF}					3				

1.7.4 Supply DC Characteristics (over recommended operating conditions unless otherwise noted)

Parameter	Symbol	Test Conditions	0°C		+25°C			+70°C		Units	
			min	max	min	typ	max	min	max		
V_{PP} quiescent supply current	I_{PPQ}	All switches off All switches on, $I_{SW}=5mA$	-	-	-	0.1	10	-	-	μA	
V_{NN} quiescent supply current	I_{NNQ}	All switches off All switches on, $I_{SW}=5mA$	-	-	-	-0.1	-10	-	-		
V_{PP} operating supply current	I_{PP}	$V_{PP}=40V$, $V_{NN}=-160V$	50kHz output switching frequency with no load	-	6.5	-	-	7	-	8	mA
		$V_{PP}=100V$, $V_{NN}=-100V$		-	5	-	-	5.5	-	5.5	
		$V_{PP}=160V$, $V_{NN}=-40V$		-	5	-	-	5	-	5.5	
V_{NN} operating supply current	I_{NN}	$V_{PP}=40V$, $V_{NN}=-160V$	50kHz output switching frequency with no load	-	6.5	-	-	7	-	8	mA
		$V_{PP}=100V$, $V_{NN}=-100V$		-	5	-	-	5.5	-	5.5	
		$V_{PP}=160V$, $V_{NN}=-40V$		-	5	-	-	5	-	5.5	
V_{DD} average supply current	I_{DD}	$f_{CLK}=5MHz$, $V_{DD}=5V$	-	4	-	-	4	-	4	mA	
V_{DD} quiescent supply current	I_{DDQ}	-	-	10	-	0.03	10	-	10	μA	

2. Functional Description

The CPC7232 takes a serial stream of input data along with a synchronous clock signal. As the clock transits from low to high, the data at the input of each shift register is shifted through from SR(n) to SR(n+1). A high data bit, a "1," represents an ON switch; a low data bit, a "0," represents an OFF switch. Data is input and shifted through the internal shift register until all eight shift register positions, SR0 through SR7, are in the desired state.

D_{IN}: The data-in line presents data bits to the CPC7232 to be shifted through the internal shift register.

CLK: The clock signal's rising edge is associated only with shifting data into and through the shift register.

CL: The clear line overrides all other inputs. When CL is high, the shift register is cleared to all 0s and all latches are set low, which causes all output switches to be turned OFF immediately. When CL is low, all output switches remain in whatever state they are in, ON or OFF, in response to CLK, latch inputs, and the LE signal.

\overline{LE} : latch enable controls the state of the latches and thus the state of the eight switches. If LE is high, then the latches do not change states, but retain their most recent status: either ON or OFF. With LE high, input data and CLK have no effect on the state of the output switches. If LE is low, then all latch outputs and their switch states follow the inputs from the shift register. LE is overridden by CL: no matter what state LE is in, CL clears the latches. See **"Truth Table" on page 10**.

D_{OUT}: The data-out pin is the output of SR7. After eight clock pulses, the first bit of eight input data bits is shifted to SR7 and appears on D_{OUT}.

SW0 - SW7: The CPC7232 provides eight high-voltage SPST output switches with a typical on-resistance of 20Ω. The two connections of each switch are not polarity-sensitive.

V_{PP} and V_{NN}: Voltage inputs to the level shifters for each switch channel that translate the voltage level of the latch output signals to an appropriate level for the voltages being switched.

The high-voltage output switches are turned on and off in response to the data sent into the latches from the shift register: data 0 turns a switch OFF, data 1 turns a switch ON.

Two or more CPC7232 devices can be cascaded to form an n-switch arrangement. The D_{OUT} pin of the first is connected to the D_{IN} pin of the next in the series. All devices are connected to the same clock (CLK) signal. LE of all devices would normally be connected, as would CL, but this is not necessary.

The first data bit applied to D_{IN} of the CPC7232, whether it's a single device or several cascaded devices, ripples through to the last switch output in line after the application of a full clocking sequence of 8 clock pulses per CPC7232. Setting the serial I/O device to output the most significant bit (MSB) first, results in the MSB appearing on SW7 of the last device in line after a full clocking sequence.

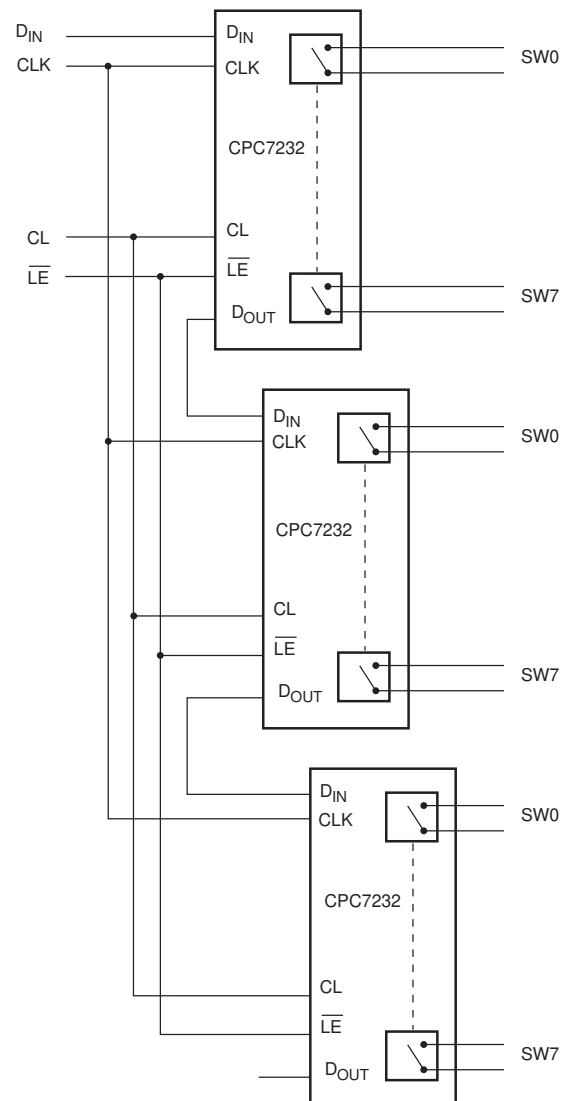

2.1 Truth Table

D0	D1	D2	D3	D4	D5	D6	D7	LE	CL	SW0	SW1	SW2	SW3	SW4	SW5	SW6	SW7
L								L	L	OFF							
H								L	L	ON							
	L							L	L		OFF						
	H							L	L		ON						
		L						L	L			OFF					
		H						L	L			ON					
			L					L	L				OFF				
			H					L	L				ON				
				L				L	L					OFF			
				H				L	L					ON			
					L			L	L						OFF		
					H			L	L						ON		
						L		L	L							OFF	
						H		L	L							ON	
							L	L	L								OFF
							H	L	L								ON
X	X	X	X	X	X	X	X	H	L	HOLD PREVIOUS STATE							
X	X	X	X	X	X	X	X	X	H	OFF	OFF	OFF	OFF	OFF	OFF	OFF	OFF

Notes:

1. The eight switches operate independently.
2. Serial data is clocked in on the rising edge of the CLOCK signal.
3. The switches go to a state retaining their present condition at the rising edge of \overline{LE} . When \overline{LE} is low the shift register data flows through the latch.
4. D_{OUT} is high when switch 7 is on.
5. Shift register clocking has no effect on the switch states if \overline{LE} is H.
6. The clear input overrides all other inputs.

2.2 Logic Timing Waveforms

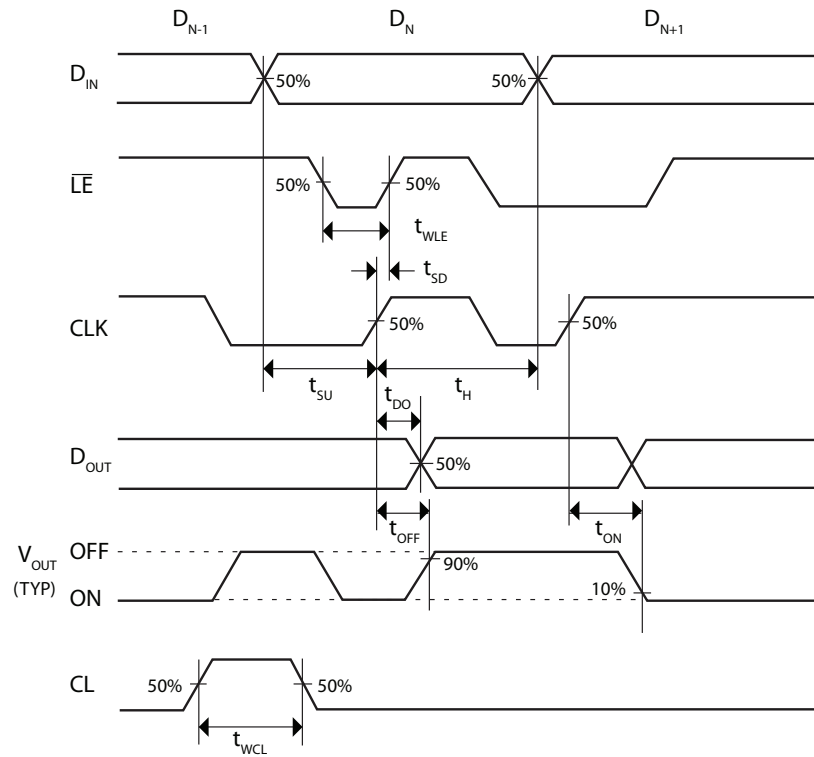

3 Manufacturing Information

3.1 Moisture Sensitivity



All plastic encapsulated semiconductor packages are susceptible to moisture ingress. IXYS Integrated Circuits Division classified all of its plastic encapsulated devices for moisture sensitivity according to the latest version of the joint industry standard, **IPC/JEDEC J-STD-020**, in force at the time of product evaluation. We test all of our products to the maximum conditions set forth in the standard, and guarantee proper operation of our devices when handled according to the limitations and information in that standard as well as to any limitations set forth in the information or standards referenced below.

Failure to adhere to the warnings or limitations as established by the listed specifications could result in reduced product performance, reduction of operable life, and/or reduction of overall reliability.

This product carries a **Moisture Sensitivity Level (MSL) rating** as shown below, and should be handled according to the requirements of the latest version of the joint industry standard **IPC/JEDEC J-STD-033**.

Device	Moisture Sensitivity Level (MSL) Rating
CPC7232W	MSL 1
CPC7232K	MSL 3

3.2 ESD Sensitivity



This product is **ESD Sensitive**, and should be handled according to the industry standard **JESD-625**.

3.3 Soldering Profile

This product has a maximum body temperature and time rating as shown below. All other guidelines of **J-STD-020** must be observed.

Device	Maximum Temperature x Time
CPC7232W	245°C for 30 seconds
CPC7232K	260°C for 30 seconds

3.4 Board Wash

IXYS Integrated Circuits Division recommends the use of no-clean flux formulations. However, board washing to remove flux residue is acceptable, and the use of a short drying bake may be necessary. Chlorine-based or Fluorine-based solvents or fluxes should not be used. Cleaning methods that employ ultrasonic energy should not be used.



3.5 Mechanical Dimensions

3.5.1 CPC7232W 28-Pin PLCC Package

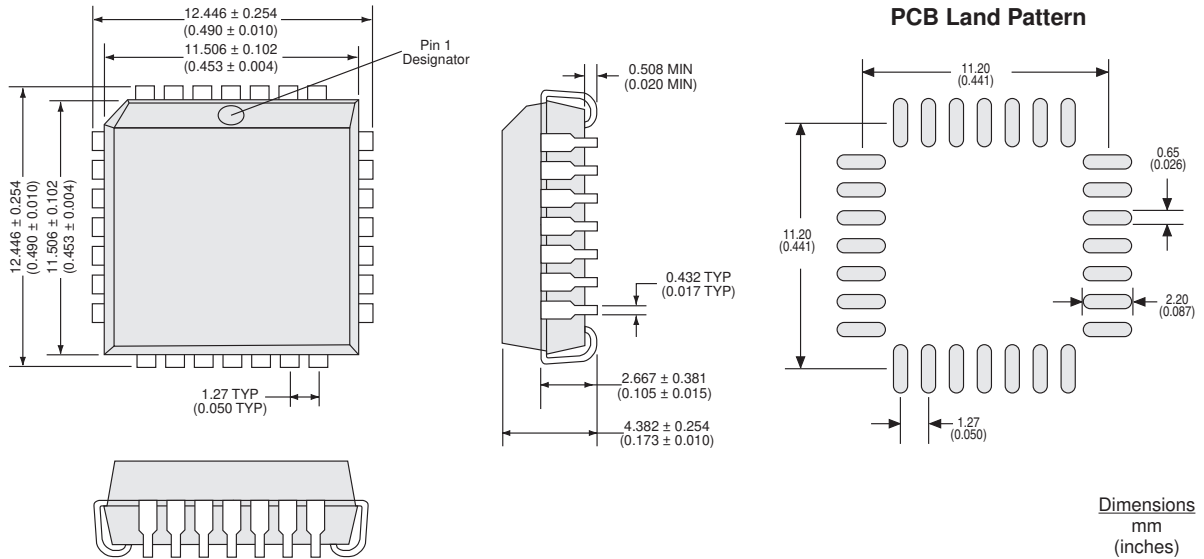

3.5.2 CPC7232K 48-Pin LQFP Package

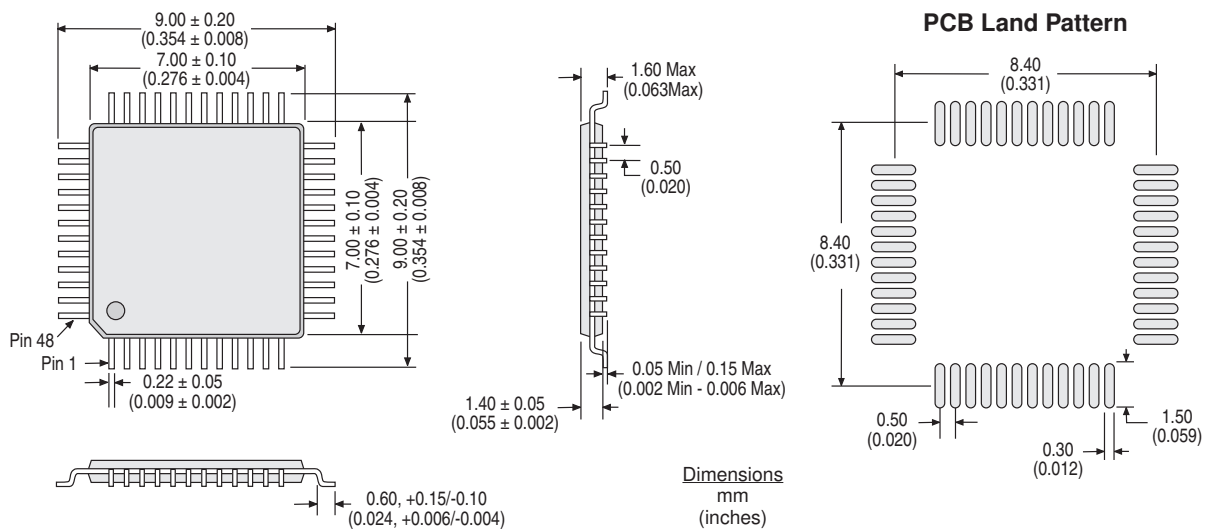

3.6 Tape and Reel Specifications

3.6.1 CPC7232WTR PLCC-28 Tape & Reel

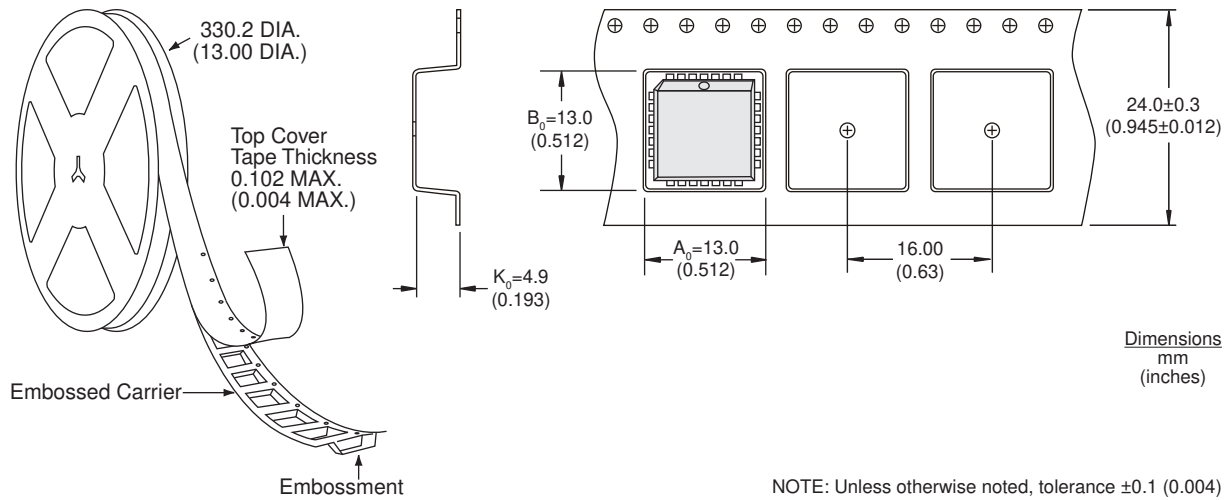

3.6.2 CPC7232KTR LQFP-48 Tape & Reel

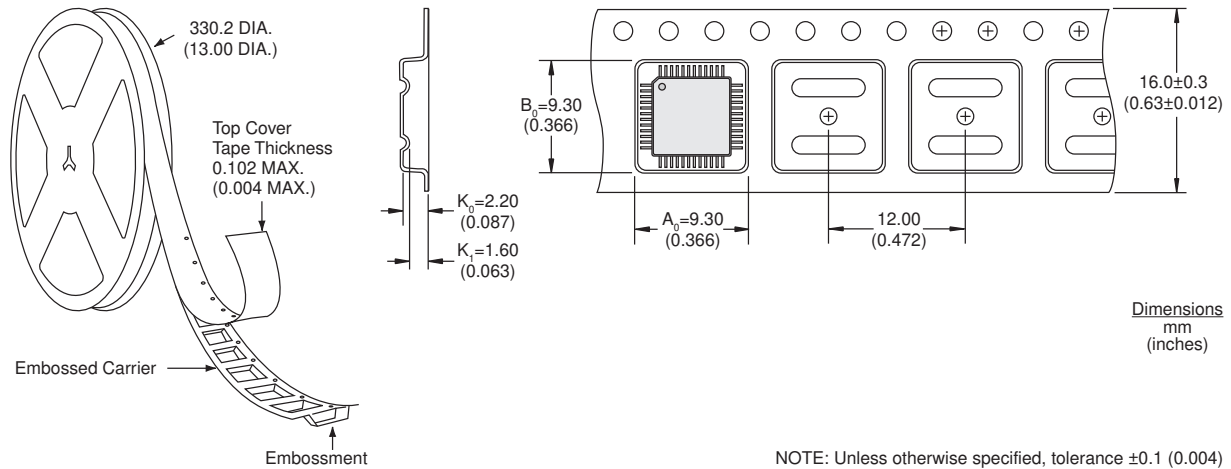

For additional information please visit www.ixysic.com

IXYS Integrated Circuits Division makes no representations or warranties with respect to the accuracy or completeness of the contents of this publication and reserves the right to make changes to specifications and product descriptions at any time without notice. Neither circuit patent licenses nor indemnity are expressed or implied. Except as set forth in IXYS Integrated Circuits Division's Standard Terms and Conditions of Sale, IXYS Integrated Circuits Division assumes no liability whatsoever, and disclaims any express or implied warranty, relating to its products including, but not limited to, the implied warranty of merchantability, fitness for a particular purpose, or infringement of any intellectual property right.

The products described in this document are not designed, intended, authorized or warranted for use as components in systems intended for surgical implant into the body, or in other applications intended to support or sustain life, or where malfunction of IXYS Integrated Circuits Division's product may result in direct physical harm, injury, or death to a person or severe property or environmental damage. IXYS Integrated Circuits Division reserves the right to discontinue or make changes to its products at any time without notice.

Specification: DS-DS-CPC7232-R02
 © Copyright 2015, IXYS Integrated Circuits Division
 All rights reserved. Printed in USA.
 5/15/2015