



Chipsmall Limited consists of a professional team with an average of over 10 year of expertise in the distribution of electronic components. Based in Hongkong, we have already established firm and mutual-benefit business relationships with customers from,Europe,America and south Asia,supplying obsolete and hard-to-find components to meet their specific needs.

With the principle of “Quality Parts,Customers Priority,Honest Operation,and Considerate Service”,our business mainly focus on the distribution of electronic components. Line cards we deal with include Microchip,ALPS,ROHM,Xilinx,Pulse,ON,Everlight and Freescale. Main products comprise IC,Modules,Potentiometer,IC Socket,Relay,Connector.Our parts cover such applications as commercial,industrial, and automotives areas.

We are looking forward to setting up business relationship with you and hope to provide you with the best service and solution. Let us make a better world for our industry!



Contact us

Tel: +86-755-8981 8866 Fax: +86-755-8427 6832

Email & Skype: info@chipsmall.com Web: www.chipsmall.com

Address: A1208, Overseas Decoration Building, #122 Zhenhua RD., Futian, Shenzhen, China



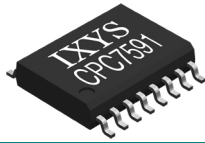

Features

- TTL Logic Level Inputs for 3.3V Logic Interfaces
- Smart Logic for Power Up / Hot Plug State Control
- Improved Switch dV/dt Immunity of 500 V/ μ s
- Monolithic IC Reliability
- Low, Matched R_{ON}
- Eliminates the Need for Zero-Cross Switching
- Flexible Switch Timing for Transition from Ringing Mode to Idle/Talk Mode.
- Clean, Bounce-Free Switching
- Tertiary Protection Consisting of Integrated Current Limiting, Voltage Clamping, and Thermal Shutdown for SLIC Protection
- 5V Operation with Power Consumption < 10 mW
- Intelligent Battery Monitor
- Latched Logic-Level Inputs, no External Drive Circuitry
- Small 16-pin SOIC

Applications

- VoIP Gateways
- Central office (CO)
- Digital Loop Carrier (DLC)
- PBX Systems
- Digitally Added Main Line (DAML)
- Hybrid Fiber Coax (HFC)
- Fiber in the Loop (FITL)
- Pair Gain System
- Channel Banks

Description

The CPC7591 is a member of IXYS Integrated Circuits Division's next generation Line Card Access Switch (LCAS) family. This monolithic 4-pole solid state switch is available in a 16-pin SOIC package. It provides the necessary functions to replace the 2-Form-C electromechanical ringing relay and it's associated snubber circuitry on traditional analog line cards or contemporary integrated voice and data (IVD) line cards found in Central Office (CO), Access, and PBX equipment. Because this device contains solid state switches for tip and ring line break and for ringing injection/return, it requires only a +5 V supply for operation and TTL logic-level inputs for control. The CPC7591 provides stable start-up conditioning during system power up and for hot plug insertion applications. Once active, the inputs respond to traditional TTL logic levels, enabling the CPC7591 to be used with 3.3V-only logic.

For negative transient voltage protection the CPC7591BA version includes SCRs to provide voltage fold-back protection for the SLIC and subsequent circuitry, while the CPC7591BB version utilizes clamping diodes to the V_{BAT} pin. For positive transient voltage protection all versions provide clamping diodes to the F_{GND} pin.

Ordering Information

Part #	Description
CPC7591BA	16-Pin SOIC, with Protection SCR, 50/Tube
CPC7591BATR	16-Pin SOIC, with Protection SCR, 1000/Reel
CPC7591BB	16-Pin SOIC, without Protection SCR, 50/Tube
CPC7591BBTR	16-Pin SOIC, without Protection SCR, 1000/Reel



Figure 1. CPC7591 Block Diagram

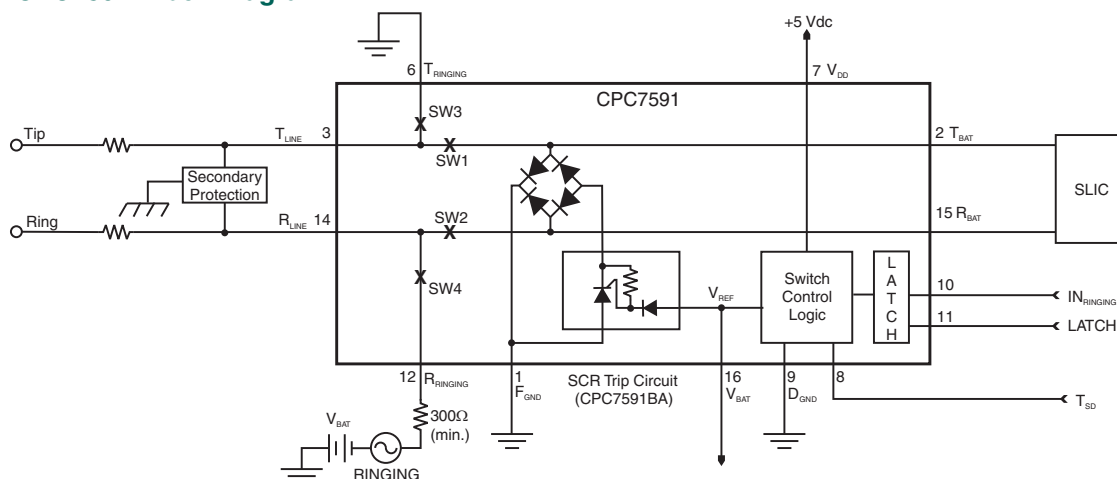

1. Specifications	3
1.1 Package Pinout	3
1.2 Pinout	3
1.3 Absolute Maximum Ratings	4
1.4 ESD Rating	4
1.5 General Conditions	4
1.6 Switch Specifications	5
1.6.1 Break Switches, SW1 and SW2	5
1.6.2 Ringing Return Switch, SW3	6
1.6.3 Ringing Switch, SW4	7
1.7 Digital I/O Electrical Specifications	8
1.8 Voltage and Power Specifications	8
1.9 Protection Circuitry Electrical Specifications	9
1.10 Truth Table	9
2. Functional Description	10
2.1 Introduction	10
2.2 Under Voltage Switch Lock Out Circuitry	10
2.2.1 Introduction	10
2.2.2 Hot Plug and Power Up Circuit Design Considerations	11
2.3 Switch Logic	11
2.3.1 Start-up	11
2.3.2 Switch Timing	11
2.3.3 Make-Before-Break Operation	11
2.3.4 Break-Before-Make Operation	12
2.4 Data Latch	13
2.5 T _{SD} Pin Description	13
2.6 Ringing Switch Zero-Cross Current Turn Off	13
2.7 Power Supplies	13
2.8 Battery Voltage Monitor	13
2.9 Protection	14
2.9.1 Diode Bridge/SCR	14
2.9.2 Current Limiting function	14
2.10 Thermal Shutdown	14
2.11 External Protection Elements	15
3. Manufacturing Information	16
3.1 Moisture Sensitivity	16
3.2 ESD Sensitivity	16
3.3 Reflow Profile	16
3.4 Board Wash	16
3.5 Mechanical Dimensions	17
3.5.1 CPC7591BA, CPC7591BB	17
3.5.2 CPC7591BATR, CPC7591BBTR Tape & Reel	17

1. Specifications

1.1 Package Pinout

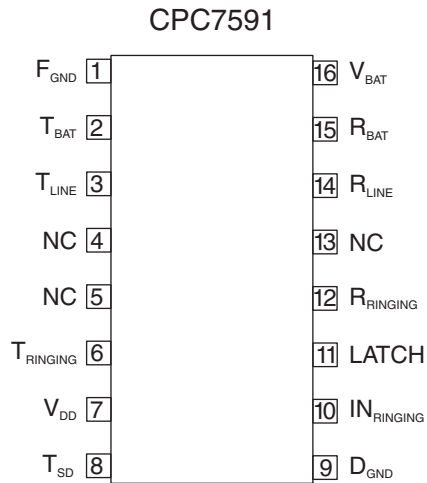

1.2 Pinout

Pin	Name	Description
1	F _{GND}	Fault ground.
2	T _{BAT}	Tip lead to the SLIC.
3	T _{LINE}	Tip lead of the line side.
4	NC	No connection.
5	NC	No connection.
6	T _{RINGING}	Ringing generator return.
7	V _{DD}	+5 V supply.
8	T _{SD}	Temperature shutdown pin.
9	D _{GND}	Digital ground.
10	IN _{RINGING}	Logic control input.
11	LATCH	Data latch enable control input.
12	R _{RINGING}	Ringing generator source.
13	NC	No connection.
14	R _{LINE}	Ring lead of the line side.
15	R _{BAT}	Ring lead to the SLIC.
16	V _{BAT}	Battery supply.

1.3 Absolute Maximum Ratings

Parameter	Minimum	Maximum	Unit
+5 V power supply (V_{DD})	-0.3	7	V
Battery Supply	-	-85	V
D_{GND} to F_{GND} Separation	-5	+5	V
Logic input voltage	-0.3	$V_{DD} + 0.3$	V
Logic input to switch output isolation	-	320	V
Switch open-contact isolation (SW1, SW2, SW3)	-	320	V
Switch open-contact isolation (SW4)	-	465	V
Operating relative humidity	5	95	%
Operating temperature	-40	+110	°C
Storage temperature	-40	+150	°C

Absolute maximum electrical ratings are at 25°C.

Absolute maximum ratings are stress ratings. Stresses in excess of these ratings can cause permanent damage to the device. Functional operation of the device at conditions beyond those indicated in the operational sections of this data sheet is not implied.

1.4 ESD Rating

ESD Rating (Human Body Model)
1000 V

1.5 General Conditions

Unless otherwise specified, minimum and maximum values are guaranteed by production testing requirements.

Typical values are characteristic of the device at +25°C and are the result of engineering evaluations. They are provided for information purposes only and are not part of the manufacturing testing requirements.

Specifications cover the operating temperature range $T_A = -40^{\circ}\text{C}$ to $+85^{\circ}\text{C}$. Also, unless otherwise specified all testing is performed with $V_{DD} = 5V_{dc}$, logic low input voltage is $0V_{dc}$ and logic high voltage is $5V_{dc}$.

1.6 Switch Specifications

1.6.1 Break Switches, SW1 and SW2

Parameter	Test Conditions	Symbol	Minimum	Typical	Maximum	Unit	
Off-State Leakage Current	V_{SW1} (differential) = T_{LINE} to T_{BAT} V_{SW2} (differential) = R_{LINE} to R_{BAT} All-Off state.						
	+25° C, V_{SW} (differential) = -320 V to gnd V_{SW} (differential) = +260 V to -60 V	I_{SW}	-	0.1	1	μA	
	+85° C, V_{SW} (differential) = -330 V to gnd V_{SW} (differential) = +270 V to -60 V			0.3			
	-40° C, V_{SW} (differential) = -310 V to gnd V_{SW} (differential) = +250 V to -60 V			0.1			
On Resistance	$I_{SW(on)}$ = ± 10 mA, ± 40 mA, R_{BAT} and T_{BAT} = -2 V						
	+25° C	R_{ON}	-	14.5	-	Ω	
	+85° C			20.5	28		
	-40° C			10.5	-		
On Resistance Matching	Per SW1 & SW2 On Resistance test conditions.	ΔR_{ON}	-	0.15	0.8	Ω	
DC current limit	$V_{SW(on)}$ = ± 10 V						
	+25° C	I_{SW}	-	300	-	mA	
	+85° C			80			160
	-40° C			-			400
Dynamic current limit ($t \leq 0.5 \mu s$)	Break switches on, all other switches off. Apply ± 1 kV 10x1000 μs pulse with appropriate protection in place.	I_{SW}	-	2.5	-	A	
Logic input to switch output isolation	Logic Inputs = GND						
	+25° C, V_{SW} (T_{LINE} , R_{LINE}) = ± 320 V	I_{SW}	-	0.1	1	μA	
	+85° C, V_{SW} (T_{LINE} , R_{LINE}) = ± 330 V			0.3			
	-40° C, V_{SW} (T_{LINE} , R_{LINE}) = ± 310 V			0.1			
dV/dt sensitivity	100VPP Square Wave, 100Hz (Not production tested - limits are guaranteed by design and quality control sampling audits.)	-	-	500	-	V/ μs	

1.6.2 Ringing Return Switch, SW3

Parameter	Test Conditions	Symbol	Minimum	Typical	Maximum	Unit	
Off-State Leakage Current	V_{SW3} (differential) = T_{LINE} to $T_{RINGING}$ All-Off state.						
	+25° C, V_{SW} (differential) = -320 V to gnd V_{SW} (differential) = +260 V to -60 V	I_{SW}	-	0.1	1	μA	
	+85° C, V_{SW} (differential) = -330 V to gnd V_{SW} (differential) = +270 V to -60 V			0.3			
	-40° C, V_{SW} (differential) = -310 V to gnd V_{SW} (differential) = +250 V to -60 V			0.1			
On Resistance	$I_{SW(on)}$ = ± 0 mA, ± 10 mA						
	+25° C	R_{ON}	-	60	-	Ω	
	+85° C			85	100		
	-40° C			45	-		
DC current limit	V_{SW} (on) = ± 10 V						
	+25° C	I_{SW}	-	135	-	mA	
	+85° C			70			85
	-40° C			-			210
Dynamic current limit ($t \leq 0.5 \mu s$)	Ring switches on, all other switches off. Apply ± 1 kV $10 \times 1000 \mu s$ pulse with appropriate protection in place.	I_{SW}	-	2.5	-	A	
Logic input to switch output isolation	Logic inputs = GND						
	+25° C, V_{SW} ($T_{RINGING}$, T_{LINE}) = $\pm 320V$	I_{SW}	-	0.1	1	μA	
	+85° C, V_{SW} ($T_{RINGING}$, T_{LINE}) = $\pm 330V$			0.3			
	-40° C, V_{SW} ($T_{RINGING}$, T_{LINE}) = $\pm 310 V$			0.1			
dV/dt sensitivity	100VPP Square Wave, 100Hz (Not production tested - limits are guaranteed by design and quality control sampling audits.)	-	-	500	-	V/ μs	

1.6.3 Ringing Switch, SW4

Parameter	Test Conditions	Symbol	Minimum	Typical	Maximum	Unit
Off-State Leakage Current	V_{SW4} (differential) = R_{LINE} to $R_{RINGING}$ All-Off state.					
	+25° C V_{SW} (differential) = -255 V to +210 V V_{SW} (differential) = +255 V to -210 V	I_{SW}	-	0.05	1	μA
	+85° C V_{SW} (differential) = -270 V to +210 V V_{SW} (differential) = +270 V to -210 V			0.1		
	-40° C V_{SW} (differential) = -245 V to +210 V V_{SW} (differential) = +245 V to -210 V			0.05		
On Resistance	I_{SW} (on) = ± 70 mA, ± 80 mA	R_{ON}	-	10	15	Ω
On Voltage	I_{SW} (on) = ± 1 mA	V_{ON}	-	1.5	3	V
On-State Leakage Current	Inputs set for ringing -Measure ringing generator current to ground.	$I_{RINGING}$	-	0.1	0.25	mA
Steady-State Current*	Inputs set for ringing mode.	I_{SW}	-	-	150	mA
Surge Current*	Ringing switches on, all other switches off. Apply ± 1 kV 10x1000 μs pulse with appropriate protection in place.	I_{SW}	-	-	2	A
Release Current	SW4 transition from on to off.	$I_{RINGING}$	-	300	-	μA
Logic input to switch output isolation	Logic inputs = GND					
	+25° C, V_{SW} ($R_{RINGING}$, R_{LINE}) = $\pm 320V$	I_{SW}	-	0.1	1	μA
	+85° C, V_{SW} ($R_{RINGING}$, R_{LINE}) = $\pm 330V$			0.3		
-40° C, V_{SW} ($R_{RINGING}$, R_{LINE}) = $\pm 310 V$	0.1					
dV/dt sensitivity	100VPP Square Wave, 100Hz (Not production tested - limits are guaranteed by design and quality control sampling audits.)	-	-	500	-	V/ μs

*Secondary protection and current limiting must prevent exceeding this parameter.

1.7 Digital I/O Electrical Specifications

Parameter	Test Conditions	Symbol	Minimum	Typical	Maximum	Unit
Input Characteristics						
Input voltage, Logic low	Input voltage falling	V_{IL}	0.8	1.1		V
Input voltage, Logic high	Input voltage rising	V_{IH}		1.7	2.0	
Input leakage current, $I_{NRINGING}$, Logic high	$V_{DD} = 5.5\text{ V}$, $V_{BAT} = -75\text{ V}$, $V_{IH} = 2.4\text{ V}$	I_{IH}	-	0.1	1	μA
Input leakage current, $I_{NRINGING}$, Logic low	$V_{DD} = 5.5\text{ V}$, $V_{BAT} = -75\text{ V}$, $V_{IL} = 0.4\text{ V}$	I_{IL}	-	0.1	1	μA
Input leakage current, LATCH Logic high	$V_{DD} = 4.5\text{ V}$, $V_{BAT} = -75\text{ V}$, $V_{IH} = 2.4\text{ V}$	I_{IH}	7	19	-	μA
LATCH Pull-up Minimum Load	$V_{DD} = 4.5\text{ V}$, $V_{BAT} = -75\text{ V}$, $I_{IN} = -10\ \mu\text{A}$ Latch input transitions to logic high.	Logic = High	True			
Input leakage current, LATCH Logic low	$V_{DD} = 5.5\text{ V}$, $V_{BAT} = -75\text{ V}$, $V_{IL} = 0.4\text{ V}$	I_{IL}	-	46	125	μA
Input leakage current, T_{SD} Logic high	$V_{DD} = 5.5\text{ V}$, $V_{BAT} = -75\text{ V}$, $V_{IH} = 2.4$	I_{IH}	10	16	30	μA
Input leakage current, T_{SD} Logic low	$V_{DD} = 5.5\text{ V}$, $V_{BAT} = -75\text{ V}$, $V_{IL} = 0.4\text{ V}$	I_{IL}	10	16	30	μA
Output Characteristics						
Output voltage, T_{SD} Logic high	$V_{DD} = 5.5\text{ V}$, $V_{BAT} = -75\text{ V}$, $I_{TSD} = 10\ \mu\text{A}$	V_{TSD_off}	2.4	V_{DD}	-	V
Output voltage, T_{SD} Logic low	$V_{DD} = 5.5\text{ V}$, $V_{BAT} = -75\text{ V}$, $I_{TSD} = 1\text{ mA}$	V_{TSD_on}	-	0	0.4	V

1.8 Voltage and Power Specifications

Parameter	Test Conditions	Symbol	Minimum	Typical	Maximum	Unit
Voltage Requirements						
V_{DD}	-	V_{DD}	4.5	5.0	5.5	V
V_{BAT}^1	-	V_{BAT}	-19	-48	-72	V
¹ V_{BAT} is used only for internal protection circuitry. If V_{BAT} goes more positive than -10 V, the device will enter the all-off state, and will remain in the all-off state until the battery goes more negative than -15 V						
Power Specifications						
Power consumption	$V_{DD} = 5\text{ V}$, $V_{BAT} = -48\text{ V}$, Measure I_{DD} and I_{BAT}					
	Talk and All-Off states	P	-	5.5	10.5	mW
	Ringing state	P	-	6.5	10.5	mW
V_{DD} current	$V_{DD} = 5\text{ V}$, $V_{BAT} = -48\text{ V}$					
	Talk and All-Off states	I_{DD}	-	1.1	2.0	mA
	Ringing state	I_{DD}	-	1.3	2.0	mA
V_{BAT} current	$V_{DD} = 5\text{ V}$, $V_{BAT} = -48\text{ V}$, All states	I_{BAT}	-	0.1	10	μA

1.9 Protection Circuitry Electrical Specifications

Parameter	Conditions	Symbol	Minimum	Typical	Maximum	Unit
Protection Diode Bridge						
Forward Voltage drop, continuous current (50/60 Hz)	Apply ± dc current limit of break switches	V_F	-	2.1	3.0	V
Forward Voltage drop, surge current	Apply ± dynamic current limit of break switches	V_F	-	5	-	V
Protection SCR (CPC7591xA)						
Surge current	-	-	-	-	*	A
Trigger current: Current into V_{BAT} pin.	SCR activates, +25° C	I_{TRIG}	-	65	-	mA
	SCR activates, +85° C			45		
Hold current: Current through protection SCR	SCR remains active, +25° C	I_{HOLD}	-	195	-	mA
	SCR remains active, +85° C		110	130		
Gate trigger voltage	$I_{GATE} = I_{TRIGGER}^{\S}$	V_{TBAT} or V_{RBAT}	$V_{BAT} - 4$	-	$V_{BAT} - 2$	V
Reverse leakage current	$V_{BAT} = -48 V$	I_{VBAT}	-	0.2	1.0	μA
On-state voltage	0.5 A, t = 0.5 μs	V_{TBAT} or V_{RBAT}	-	-3	-	V
	2.0 A, t = 0.5 μs			-5		
Temperature Shutdown Specifications						
Shutdown activation temperature	Not production tested - limits are guaranteed by design and Quality Control sampling audits.	T_{TSD_on}	110	125	150	°C
Shutdown circuit hysteresis		T_{TSD_off}	10	-	25	°C
*Passes GR1089 and ITU-T K.20 with appropriate secondary protection in place.						
$\S V_{BAT}$ must be capable of sourcing $I_{TRIGGER}$ for the internal SCR to activate.						

1.10 Truth Table

State	$I_{RINGING}$	Latch	T_{SD}	Break Switches	Ringing Switches
Talk	0	0	Z ¹	On	Off
Ringing	1			Off	On
Latched	X	1		Unchanged	
All-Off	X	X	0	Off	Off

¹ Z = High Impedance. Because T_{SD} has an internal pull up at this pin, it should be controlled with an open-collector or open-drain type device.

2. Functional Description

2.1 Introduction

The CPC7591 has three states:

- **Talk.** Line break switches SW1 and SW2 closed, ringing switches SW3 and SW4 open.
- **Ringing.** Ringing switches SW3 and SW4 closed, line break switches SW1 and SW2 open.
- **All-off.** All switches open.

See “[Truth Table](#)” on [page 9](#) for more information.

The CPC7591 offers break-before-make and make-before-break switching from the ringing state to the talk state with simple TTL level logic input control. Solid-state switch construction means no impulse noise is generated when switching during ringing cadence or ring trip, eliminating the need for external zero-cross switching circuitry. State-control is via TTL logic-level input so no additional driver circuitry is required. The linear line break switches SW1 and SW2 have exceptionally low R_{ON} and excellent matching characteristics. The ringing switch, SW4, has a minimum open contact breakdown voltage of 465 V at +25°C, sufficiently high with proper protection to prevent breakdown in the presence of a transient fault condition (i.e., passing the transient on to the ringing generator).

Integrated into the CPC7591 is an over-voltage clamping circuit, active current limiting, and a thermal shutdown mechanism to provide protection to the SLIC during a fault condition. Positive and negative lightning surge currents are reduced by the current limiting circuitry and hazardous potentials are diverted away from the SLIC via the protection diode bridge or the optional integrated protection SCR. Power-cross potentials are also reduced by the current limiting and thermal shutdown circuits.

To protect the CPC7591 from an overvoltage fault condition, the use of a secondary protector is required. The secondary protector must limit the voltage seen at the T_{LINE} and R_{LINE} terminals to a level below the maximum breakdown voltage of the switches. To minimize the stress on the solid-state contacts, use of

a foldback or crowbar type secondary protector is highly recommended. With proper selection of the secondary protector, a line card using the CPC7591 will meet all relevant ITU, LSSGR, TIA/EIA and IEC protection requirements.

The CPC7591 operates from a single +5 V supply only. This gives the device extremely low idle and active power consumption with virtually any range of battery voltage. The battery voltage used by the CPC7591 has a two fold function. For protection purposes it is used as a fault condition current source for the internal integrated protection circuitry. Secondly, it is used as a reference so that in the event of battery voltage loss, the CPC7591 will enter the all-off state.

2.2 Under Voltage Switch Lock Out Circuitry

2.2.1 Introduction

Smart logic in the CPC7591 now provides for switch state control during both power up and power loss transitions. An internal detector is used to evaluate the V_{DD} supply to determine when to de-assert the under voltage switch lock out circuitry with a rising V_{DD} and when to assert the under voltage switch lock out circuitry with a falling V_{DD} . Any time unsatisfactory low V_{DD} conditions exist, the lock out circuit overrides user switch control by blocking the information at the external input pins and conditioning internal switch commands to the all-off state. Upon restoration of V_{DD} , the switches will remain in the all-off state until the LATCH input is pulled low.

The rising V_{DD} switch lock-out release threshold is internally set to ensure all internal logic is properly biased and functional before accepting external switch commands from the inputs to control the switch states. For a falling V_{DD} event, the lock-out threshold is set to assure proper logic and switch behavior up to the moment the switches are forced off and external inputs are suppressed.

To facilitate hot plug insertion and system power up state control, the LATCH pin has an integrated weak pull up resistor to the V_{DD} power rail that will hold a non-driven LATCH pin at a logic high state. This enables board designers to use the CPC7591 with FPGAs and other devices that provide high impedance outputs during power up and logic configuration. The weak pull up allows a fan out of up to 32 when the system's LATCH control driver has a logic low minimum sink capability of 4mA.

2.2.2 Hot Plug and Power Up Circuit Design Considerations

There are six possible start up scenarios that can occur during power up. They are:

1. All inputs defined at power up & LATCH = 0
2. All inputs defined at power up & LATCH = 1
3. All inputs defined at power up & LATCH = Z
4. All inputs not defined at power up & LATCH = 0
5. All inputs not defined at power up & LATCH = 1
6. All inputs not defined at power up & LATCH = Z

Under all of the start up situations listed above the CPC7591 will hold all of its switches in the all-off state during power up. When V_{DD} requirements have been satisfied the LCAS will complete its start up procedure in one of three conditions.

For start up scenario 1 the CPC7591 will transition from the all-off state to the state defined by the inputs when V_{DD} is valid.

For start up scenarios 2, 3, 5, and 6 the CPC7591 will power up in the all-off state and remain there until the LATCH pin is pulled low. This allows for an indefinite all-off state for boards inserted into a powered system but are not configured for service or boards that need to wait for other devices to be configured first.

Start up scenario 4 will start up with all switches in the all-off state but upon the acceptance of a valid V_{DD} the LCAS will revert to either the talk state or the ringing state and there after may randomly change states based on input pin leakage currents and loading. Because the LCAS state after power up can not be predicted with this start up condition it should never be utilized.

On designs that do not wish to individually control the LATCH pins of multiple-port cards it is possible to bus many (or all) of the LATCH pins together to create a single board level input enable control.

2.3 Switch Logic

2.3.1 Start-up

The CPC7591 uses smart logic to monitor the V_{DD} supply. Any time the V_{DD} is below an internally set threshold, the smart logic places the control logic to the all-off state. An internal pullup on the LATCH pin locks the CPC7591 in the all-off state following start-up until the LATCH pin is pulled down to a logic low. Prior to the assertion of a logic low at the LATCH pin, the switch control inputs must be properly conditioned.

2.3.2 Switch Timing

The CPC7591 provides, when switching from the ringing state to the talk state, the ability to control the release timing of the ringing switches SW3 and SW4 relative to the state of the break switches SW1 and SW2 using simple TTL logic-level inputs. The two available techniques are referred to as make-before-break and break-before-make operation. When the switch contacts of SW1 and SW2 are closed (made) before the ringing switch contacts of SW3 and SW4 are opened (broken), this is referred to as make-before-break operation. Break-before-make operation occurs when the ringing contacts of SW3 and SW4 are opened (broken) before the switch contacts of SW1 and SW2 are closed (made). With the CPC7591, make-before-break and break-before-make operations can easily be accomplished by applying the proper sequence of TTL logic-level inputs to the device.

2.3.3 Make-Before-Break Operation

To use make-before-break operation, change the logic inputs from the ringing state directly to the talk state. Application of the talk state opens the ringing return switch, SW3, as the break switches SW1 and SW2 close. The ringing switch, SW4, remains closed until the next zero-crossing of the ringing current. While in the make-before-break state, ringing potentials in excess of the CPC7591 protection circuitry thresholds will be diverted away from the SLIC. This operational sequence is shown below in the **“Make-Before-Break Ringing to Talk Transition Logic Sequence” on page 12.**

Make-Before-Break Ringing to Talk Transition Logic Sequence

State	INRINGING	Latch	TSD	Timing	Break Switches	Ringing Return Switch (SW3)	Ringing Switch (SW4)
Ringing	1	0	Z	-	Off	On	On
Make-Before-Break	0			SW4 waiting for next zero-current crossing to turn off. Maximum time is one-half of the ringing cycle. In this transition state, current that is limited to the dc break switch current limit value will be sourced from the ring node of the SLIC.	On	Off	On
Talk	0			Zero-cross current has occurred	On	Off	Off

2.3.4 Break-Before-Make Operation

Break-before-make ringing switch release timing is performed via the bidirectional TSD interface. As an input, the TSD can disable all of the CPC7591 switches when pulled to a logic low. Although logically disabled, an active (closed) ringing switch (SW4) will remain closed until the next current zero crossing event. This operational sequence is shown below in the **“Break-Before-Make Ringing to Talk Transition Logic Sequence” on page 12.**

1. Pull TSD to a logic low to end the ringing state. This opens the ringing return switch (SW3) and prevents any other switches from closing.
2. Keep TSD low for at least one-half the duration of

the ringing cycle period to allow sufficient time for a zero crossing current event to occur and for the circuit to enter the break before make state.

3. During the TSD low period, clear the INRINGING input for the talk state (logic low).
4. Release TSD allowing the internal pull-up to activate the break switches.

When using TSD as an input, the two recommended states are “0” which overrides the logic input pins and forces an all-off state and “Z” which allows normal switch control via the logic input pins. This requires the use of an open-collector or open-drain type buffer.

Break-Before-Make Ringing to Talk Transition Logic Sequence

State	INRINGING	Latch	TSD	Timing	Break Switches	Ringing Return Switch (SW3)	Ringing Switch (SW4)
Ringing	1	0	Z	-	Off	On	On
All-off	1		0	Hold this state for one-half of the ringing cycle. SW4 waiting for zero current to turn off.	Off	Off	On
All-off	0		Zero current has occurred. SW4 has opened	Off	Off	Off	
Talk	0		Z	Close break switches	On	Off	Off

Logic states and explanations are provided in the **“Truth Table” on page 9.**

2.4 Data Latch

The CPC7591 has an integrated transparent data latch. The latch enable operation is controlled by TTL logic input levels at the LATCH pin. Data input to the latch is via the input pin $IN_{RINGING}$, while the output of the data latch are internal nodes used for state control. When the LATCH enable control pin is at logic 0 the data latch is transparent and the $IN_{RINGING}$ input data control signal flows directly through the data latch to the state control circuitry. A change in $IN_{RINGING}$ input will be reflected by a change in switch state.

Whenever the LATCH enable control pin is at logic 1, the data latch is active and data is locked. Subsequent $IN_{RINGING}$ input changes will not result in a change to the control logic or affect the existing switch state.

The switches will remain in the state they were in when the LATCH pin changes from logic 0 to logic 1 and will not respond to changes in input as long as the LATCH is at logic 1. However, neither the T_{SD} input nor the T_{SD} output control functions are affected by the latch function. Since internal thermal shutdown control and external “All-off” control is not affected by the state of the LATCH enable input, T_{SD} will override state control.

2.5 T_{SD} Pin Description

The T_{SD} pin is a bi-directional I/O structure with an internal pull-up current source with a nominal value of $16\ \mu\text{A}$ biased from V_{DD} .

As an output, this pin indicates the status of the thermal shutdown circuitry. Typically, during normal operation, this pin will be pulled up to V_{DD} but under fault conditions that create excess thermal loading the CPC7591 will enter thermal shutdown and a logic low will be output.

As an input, the T_{SD} pin is utilized to place the CPC7591 into the “All-Off” state by simply pulling the input low. For applications using low-voltage logic devices (lower than V_{DD}), IXYS IC Division recommends the use of an open-collector or an open-drain type output to control T_{SD} . This avoids sinking the T_{SD} pull up bias current to ground during normal operation when the all-off state is not required. An open-collector or open-drain type device is recommended to drive this pin.

2.6 Ringing Switch Zero-Cross Current Turn Off

After the application of a logic input to turn SW4 off, the ringing switch is designed to delay the change in state until the next zero-crossing. Once on, the switch requires a zero-current cross to turn off, and therefore should not be used to switch a pure DC signal. The switch will remain in the on state no matter the logic input until the next zero crossing. These switching characteristics will reduce and possibly eliminate overall system impulse noise normally associated with ringing switches. See IXYS IC Division’s application note [AN-144, Impulse Noise Benefits of Line Card Access Switches](#) for more information. The attributes of ringing switch SW4 may make it possible to eliminate the need for a zero-cross switching scheme. A minimum impedance of $300\ \Omega$ in series with the ringing generator is recommended.

2.7 Power Supplies

Both a +5 V supply and battery voltage are connected to the CPC7591. Switch state control is powered exclusively by the +5 V supply. As a result, the CPC7591 exhibits extremely low power consumption during active and idle states.

Although battery power is not used for switch control, it is required to supply trigger current for the integrated internal protection circuitry SCR during fault conditions. This integrated SCR is designed to activate whenever the voltage at T_{BAT} or R_{BAT} drops 2 to 4 V below the applied voltage on the V_{BAT} pin. Because the battery supply at this pin is required to source trigger current during negative overvoltage fault conditions at tip and ring, it is important that the net supplying this current be a low impedance path for high speed transients such as lightning. This will permit trigger currents to flow enabling the SCR to activate and thereby prevent a fault induced negative overvoltage event at the T_{BAT} or R_{BAT} nodes.

2.8 Battery Voltage Monitor

The CPC7591 also uses the V_{BAT} pin to monitor battery voltage. If system battery voltage is lost, the CPC7591 immediately enters the all-off state. It remains in this state until the battery voltage is restored. The device also enters the all-off state if the system battery voltage goes more positive than $-10\ \text{V}$,

and remains in the all-off state until the battery voltage goes more negative than -15 V . This battery monitor feature draws a small current from the battery (less than $1\ \mu\text{A}$ typical) and will add slightly to the device's overall power dissipation.

This monitor function performs properly if the CPC7591 and SLIC share a common battery supply origin. Otherwise, if battery is lost to the CPC7591 but not to the SLIC, then the V_{BAT} pin will be internally biased by the potential applied at the T_{BAT} or R_{BAT} pins via the internal protection circuitry SCR trigger current path.

2.9 Protection

2.9.1 Diode Bridge/SCR

The CPC7591 uses a combination of current limited break switches, a diode bridge/SCR clamping circuit, and a thermal shutdown mechanism to protect the SLIC device or other associated circuitry from damage during line transient events such as lightning. During a positive transient condition, the fault current is conducted through the diode bridge to ground via F_{GND} . Voltage is clamped to a diode drop above ground. During a negative transient of 2 to 4 V more negative than the voltage source at V_{BAT} , the SCR conducts and faults are shunted to F_{GND} via the SCR or the diode bridge.

In order for the SCR to crowbar (or foldback), the SCR's on-voltage (see **“Protection Circuitry Electrical Specifications” on page 9**) must be less than the applied voltage at the V_{BAT} pin. If the V_{BAT} voltage is less negative than the SCR on-voltage, or if the V_{BAT} supply is unable to source the trigger current, the SCR will not crowbar.

For power induction or power-cross fault conditions, the positive cycle of the transient is clamped to a diode drop above ground and the fault current is directed to ground. The negative cycle of the transient will cause the SCR to conduct when the voltage exceeds the V_{BAT} reference voltage by two to four volts, steering the fault current to ground.

Note: The CPC7591xB does not contain the protection SCR but instead uses diodes to clamp both polarities of a transient fault. These diodes direct the negative potential's fault current to the V_{BAT} pin.

2.9.2 Current Limiting function

If a lightning strike transient occurs when the device is in the talk state, the current is passed along the line to the integrated protection circuitry and restricted by the dynamic current limit response of the active switches. During the talk state when a $1000\text{V } 10\times 1000\ \mu\text{s}$ lightning pulse (GR-1089-CORE) is applied to the line through a properly clamped external protector, the current seen at T_{LINE} or R_{LINE} will be a pulse with a typical magnitude of 2.5 A and a duration less than $0.5\ \mu\text{s}$.

If a power-cross fault occurs with the device in the talk state, the current is passed through the break switches SW1 and SW2 on to the integrated protection circuit but is limited by the dynamic DC current limit response of the two break switches. The DC current limit specified over temperature is between 80 mA and 425 mA and the circuitry has a negative temperature coefficient. As a result, if the device is subjected to extended heating due to a power cross fault condition, the measured current into T_{LINE} or R_{LINE} will decrease as the device temperature increases. If the device temperature rises sufficiently, the temperature shutdown mechanism will activate and the device will enter the all-off state.

2.10 Thermal Shutdown

The thermal shutdown mechanism activates when the device die temperature reaches a minimum of 110° C , placing the device in the all-off state regardless of logic input. During thermal shutdown events the T_{SD} pin will output a logic low with a nominal 0 V level. A logic high is output from the T_{SD} pin during normal operation with a typical output level equal to V_{DD} .

If presented with a short duration transient such as a lightning event, the thermal shutdown feature will typically not activate. But in an extended power-cross event, the device temperature will rise and the thermal shutdown mechanism will activate forcing the switches to the all-off state. At this point the current measured into T_{LINE} or R_{LINE} will drop to zero. Once the device enters thermal shutdown it will remain in the all-off state until the temperature of the device drops below the de-activation level of the thermal shutdown circuit. This permits the device to autonomously return to normal operation. If the transient has not passed, current will again flow up to the value allowed by the dynamic DC current limiting of the switches and heating will resume, reactivating the thermal shutdown

mechanism. This cycle of entering and exiting the thermal shutdown mode will continue as long as the fault condition persists. If the magnitude of the fault condition is great enough, the external secondary protector will activate shunting the fault current to ground.

2.11 External Protection Elements

The CPC7591 requires only over voltage secondary protection on the loop side of the device. The integrated protection feature described above negates the need for additional external protection on the SLIC side. The secondary protector must limit voltage transients to levels that do not exceed the breakdown voltage or input-output isolation barrier of the CPC7591. A foldback or crowbar type protector is recommended to minimize stresses on the CPC7591.

Consult IXYS IC Division's application note, AN-100, "[Designing Surge and Power Fault Protection Circuits for Solid State Subscriber Line Interfaces](#)" for equations related to the specifications of external secondary protectors, fused resistors and PTCs.

3 Manufacturing Information

3.1 Moisture Sensitivity



All plastic encapsulated semiconductor packages are susceptible to moisture ingress. IXYS Integrated Circuits Division classified all of its plastic encapsulated devices for moisture sensitivity according to the latest version of the joint industry standard, **IPC/JEDEC J-STD-020**, in force at the time of product evaluation. We test all of our products to the maximum conditions set forth in the standard, and guarantee proper operation of our devices when handled according to the limitations and information in that standard as well as to any limitations set forth in the information or standards referenced below.

Failure to adhere to the warnings or limitations as established by the listed specifications could result in reduced product performance, reduction of operable life, and/or reduction of overall reliability.

This product carries a **Moisture Sensitivity Level (MSL) rating** as shown below, and should be handled according to the requirements of the latest version of the joint industry standard **IPC/JEDEC J-STD-033**.

Device	Moisture Sensitivity Level (MSL) Rating
CPC7591BA / CPC7591BB	MSL 1

3.2 ESD Sensitivity



This product is **ESD Sensitive**, and should be handled according to the industry standard **JESD-625**.

3.3 Reflow Profile

This product has a maximum body temperature and time rating as shown below. All other guidelines of **J-STD-020** must be observed.

Device	Maximum Temperature x Time
CPC7591BA / CPC7591BB	260°C for 30 seconds

3.4 Board Wash

IXYS Integrated Circuits Division recommends the use of no-clean flux formulations. However, board washing to remove flux residue is acceptable, and the use of a short drying bake may be necessary. Chlorine-based or Fluorine-based solvents or fluxes should not be used. Cleaning methods that employ ultrasonic energy should not be used.



3.5 Mechanical Dimensions

3.5.1 CPC7591BA, CPC7591BB

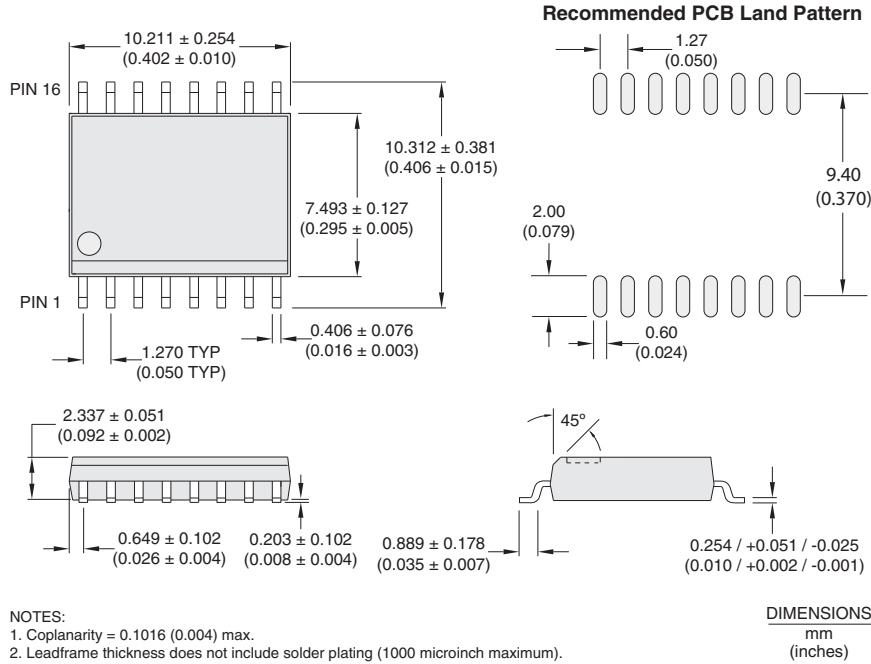

3.5.2 CPC7591BATR, CPC7591BBTR Tape & Reel

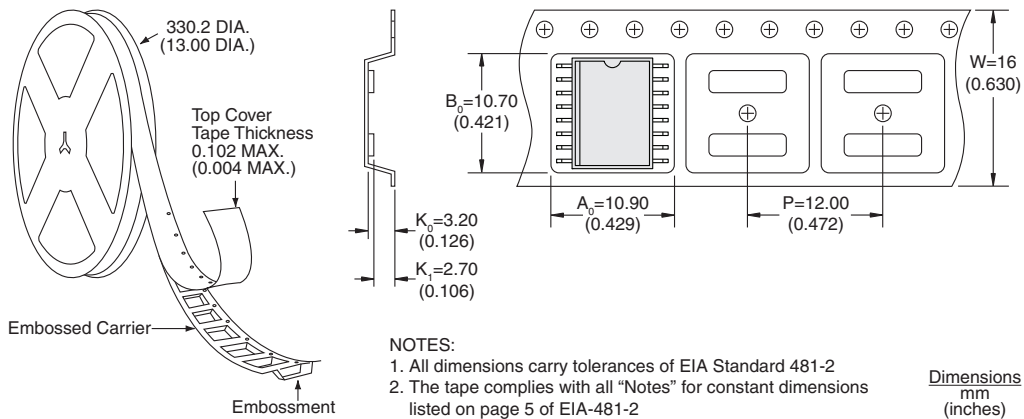

For additional information please visit www.ixysic.com

IXYS Integrated Circuits Division makes no representations or warranties with respect to the accuracy or completeness of the contents of this publication and reserves the right to make changes to specifications and product descriptions at any time without notice. Neither circuit patent licenses or indemnity are expressed or implied. Except as set forth in IXYS Integrated Circuits Division's Standard Terms and Conditions of Sale, IXYS Integrated Circuits Division assumes no liability whatsoever, and disclaims any express or implied warranty relating to its products, including, but not limited to, the implied warranty of merchantability, fitness for a particular purpose, or infringement of any intellectual property right.

The products described in this document are not designed, intended, authorized, or warranted for use as components in systems intended for surgical implant into the body, or in other applications intended to support or sustain life, or where malfunction of IXYS Integrated Circuits Division's product may result in direct physical harm, injury, or death to a person or severe property or environmental damage. IXYS Integrated Circuits Division reserves the right to discontinue or make changes to its products at any time without notice.

Specification: DS-CPC7591-R06
© Copyright 2012, IXYS Integrated Circuits Division
All rights reserved. Printed in USA.
12/18/2012