



Chipsmall Limited consists of a professional team with an average of over 10 year of expertise in the distribution of electronic components. Based in Hongkong, we have already established firm and mutual-benefit business relationships with customers from,Europe,America and south Asia,supplying obsolete and hard-to-find components to meet their specific needs.

With the principle of “Quality Parts,Customers Priority,Honest Operation,and Considerate Service”,our business mainly focus on the distribution of electronic components. Line cards we deal with include Microchip,ALPS,ROHM,Xilinx,Pulse,ON,Everlight and Freescale. Main products comprise IC,Modules,Potentiometer,IC Socket,Relay,Connector.Our parts cover such applications as commercial,industrial, and automotives areas.

We are looking forward to setting up business relationship with you and hope to provide you with the best service and solution. Let us make a better world for our industry!



Contact us

Tel: +86-755-8981 8866 Fax: +86-755-8427 6832

Email & Skype: info@chipsmall.com Web: www.chipsmall.com

Address: A1208, Overseas Decoration Building, #122 Zhenhua RD., Futian, Shenzhen, China



PART NUMBER: CPE-267

DESCRIPTION: piezo audio transducer

SPECIFICATONS

operating frequency	2.8 ± 0.5 kHz	
rated voltage	12 V dc	
operating voltage range	6 ~ 14 V dc	
current consumption	35 mA max.	at 12 V dc
sound pressure level	85 dB min.	at 30 cm/12 V dc
tone	continuous	at 12 V dc
operating temperature	-30 ~ +85° C	
storage temperature	-40 ~ +95° C	
dimensions	ø25 x H16 mm	
weight	41 g max.	
material	ABS UL-94 1/16" HB high heat (black)	
terminal	wire type	
RoHS	yes	
dustproof/waterproof level	IP67	IEC standard 529 edition 2.0(1989)

APPEARANCE DRAWING

tolerance: ±0.5

units: mm

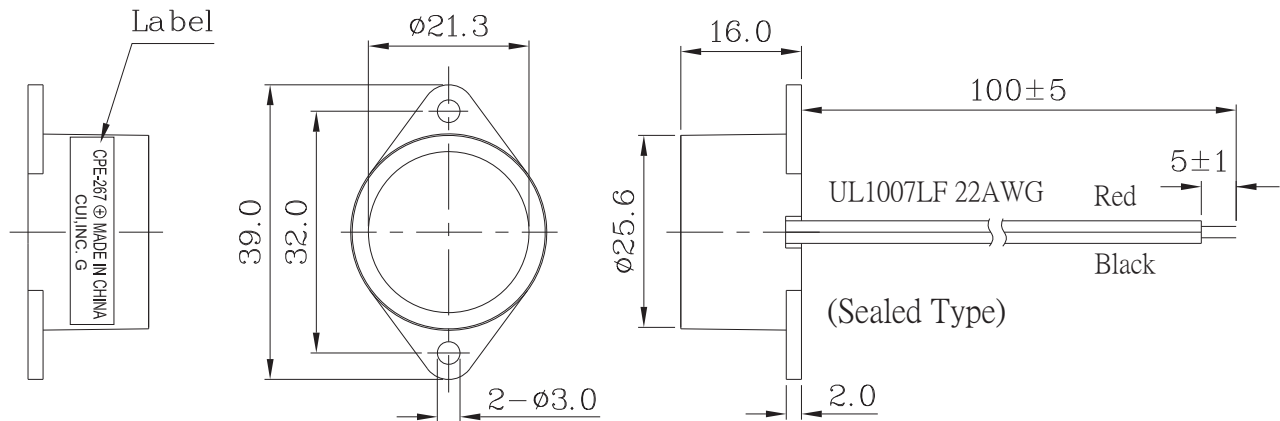

PART NUMBER: CPE-267

DESCRIPTION: piezo audio transducer

VOLTAGE: SOUND PRESSURE LEVEL / CURRENT CONSUMPTION CHARACTERISTICS

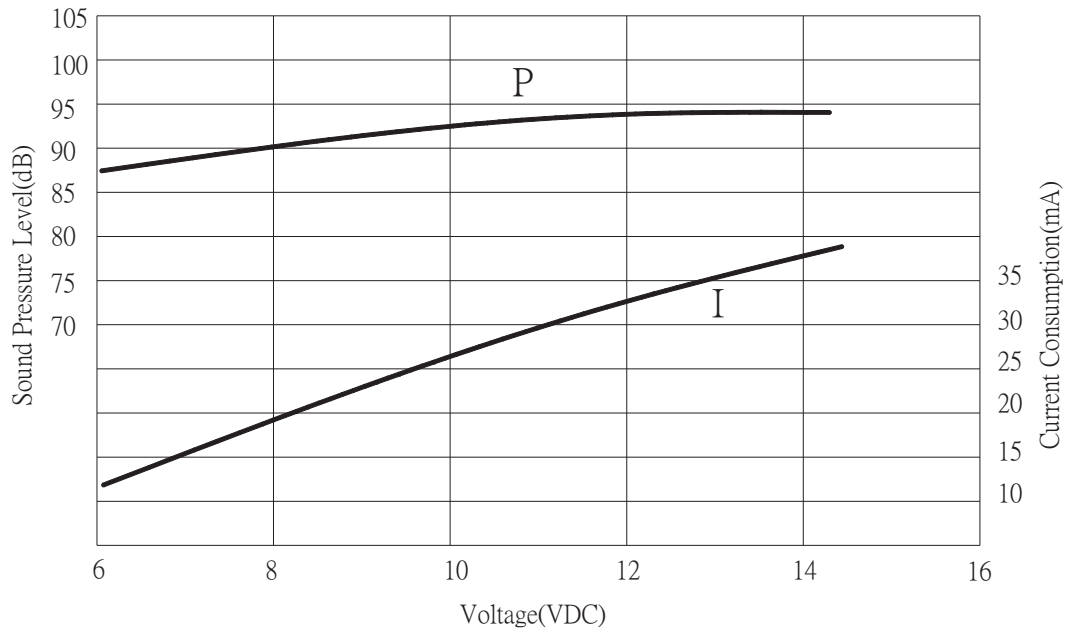

MEASUREMENT METHOD

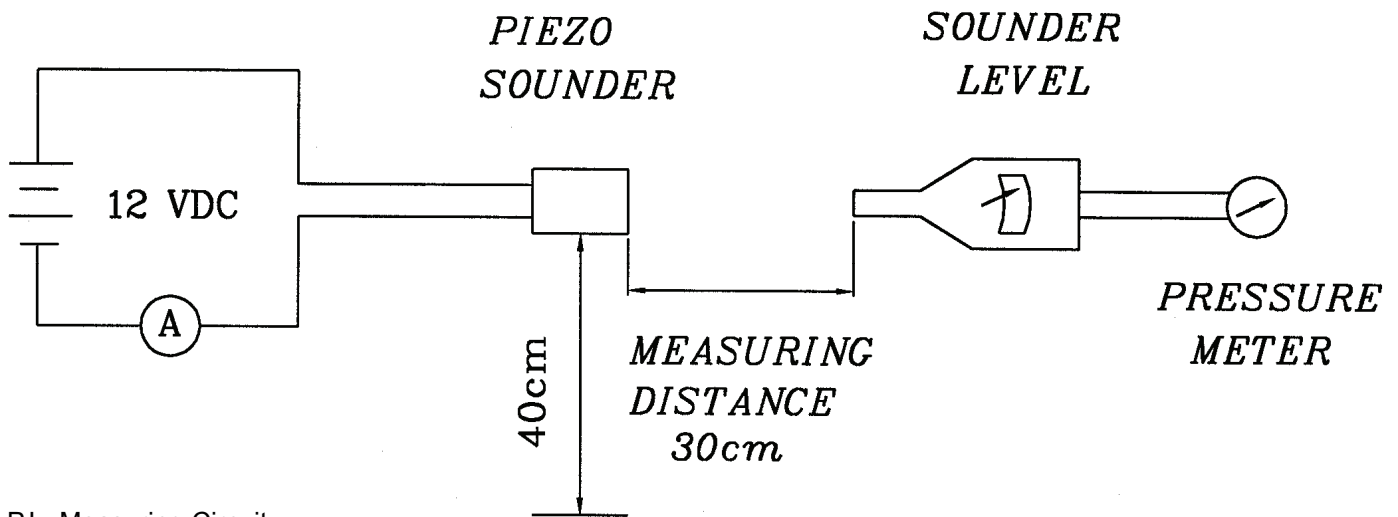

S.P.L. Measuring Circuit
 Mic: RION S.P.L. meter UC30 or equivalent
 S.G.: Hewlett Packard 33120A function generator or equivalent



PART NUMBER: CPE-267

DESCRIPTION: piezo audio transducer

MECHANICAL CHARACTERISTICS

item	test condition	evaluation standard
solderability (connector excepted)	Lead terminals are immersed in rosin for 5 seconds and then immersed in solder bath of 270 ±5°C for 3 ±0.5 seconds.	90% min. of the lead terminals will be wet with solder (except the edge of the terminal).
lead wire pull strength	The pull force shall be applied to double lead wire: Horizontal 3.0N (0.306 kg) for 30 seconds Vertical 2.0N (0.204 kg) for 30 seconds	No damage or cutting off.
vibration	The buzzer shall be measured after applying a vibration amplitude of 1.5 mm with 10 to 55 Hz band of vibration frequency to each of the 3 perpendicular directions for 2 hours.	The value of oscillation frequency/current consumption should be ±10% of the initial measurements. The SPL should be within ±10dB compared with the initial measurement.
drop test	The part will be dropped from a height of 75 cm onto a 40 mm thick wooden board 3 times in 3 axes (X, Y, Z) for a total of 9 drops.	

ENVIRONMENT TEST

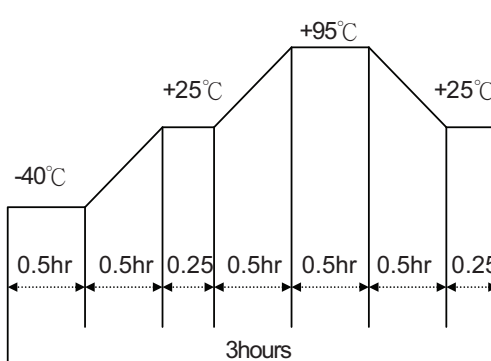
item	test condition	evaluation standard
high temp. test	After being placed in a chamber at +95°C for 240 hours.	The buzzer will be measured after being placed at +25°C for 4 hours. The value of the oscillation frequency/current consumption should be ±10% compared to the initial measurements. The SPL should be within ±10dB compared to the initial measurements.
low temp. test	After being placed in a chamber at -40°C for 240 hours.	
humidity test	After being placed in a chamber at +40°C and 90±5% relative humidity for 240 hours.	
temp. cycle test	The part shall be subjected to 5 cycles. One cycle will consist of: 	

**PART NUMBER:** CPE-267**DESCRIPTION:** piezo audio transducer**RELIABILITY TEST**

item	test condition	evaluation standard
operating (life test)	1. Continuous life test: The part will be subjected to 48 hours of continuous operation at +70°C with rated voltage applied. 2. Intermittent life test: A duty cycle of 1 minute on, 1 minute off, a minimum of 5,000 times at room temp (+25 ±2°C) with rated voltage applied.	The buzzer will be measured after being placed at +25°C for 4 hours. The value of the oscillation frequency/current consumption should be ±10% compared to the initial measurements. The SPL should be within ±10dB compared to the initial measurements.

TEST CONDITIONS

standard test condition	a) temperature: +5 ~ +35°C	b) humidity: 45 - 85%	c) pressure: 860-1060 mbar
judgement test condition	a) temperature: +25 ±2°C	b) humidity: 60 - 70%	c) pressure: 860-1060 mbar

PART NUMBER: CPE-267

DESCRIPTION: piezo audio transducer

PACKAGING

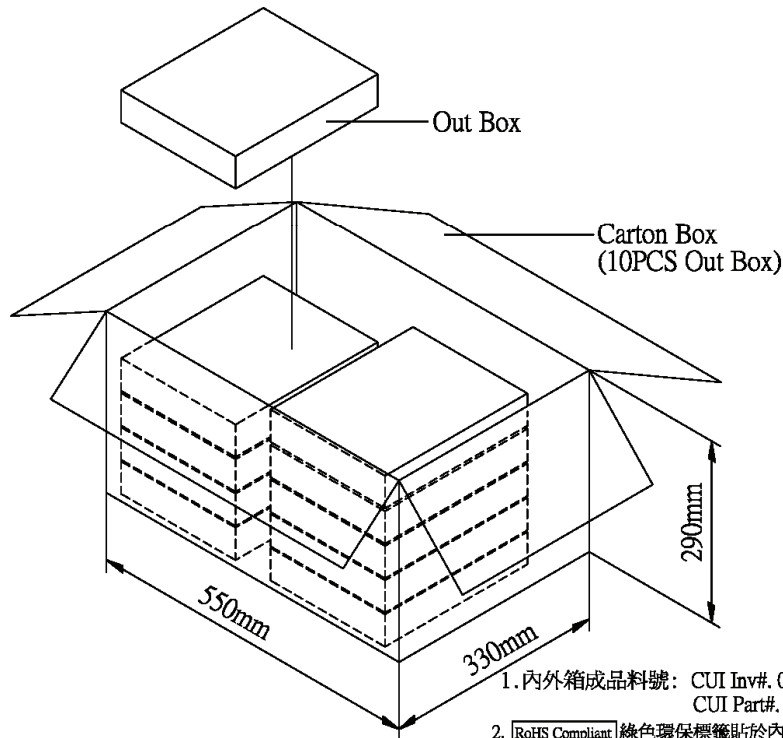
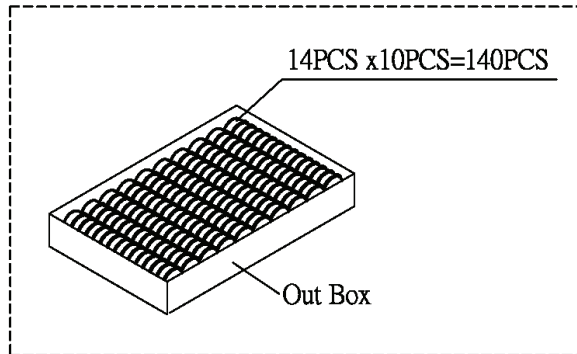

Out Box	310mmx248mmx49mm	1x140PCS=140PCS
Carton Box	550mmx330mmx290mm	100PCSx10=1,400PCS