



Chipsmall Limited consists of a professional team with an average of over 10 year of expertise in the distribution of electronic components. Based in Hongkong, we have already established firm and mutual-benefit business relationships with customers from,Europe,America and south Asia,supplying obsolete and hard-to-find components to meet their specific needs.

With the principle of “Quality Parts,Customers Priority,Honest Operation,and Considerate Service”,our business mainly focus on the distribution of electronic components. Line cards we deal with include Microchip,ALPS,ROHM,Xilinx,Pulse,ON,Everlight and Freescale. Main products comprise IC,Modules,Potentiometer,IC Socket,Relay,Connector.Our parts cover such applications as commercial,industrial, and automotives areas.

We are looking forward to setting up business relationship with you and hope to provide you with the best service and solution. Let us make a better world for our industry!



Contact us

Tel: +86-755-8981 8866 Fax: +86-755-8427 6832

Email & Skype: info@chipsmall.com Web: www.chipsmall.com

Address: A1208, Overseas Decoration Building, #122 Zhenhua RD., Futian, Shenzhen, China



Reference Design for CS42L51

Features

- ◆ Ultra Small Layout
- ◆ Single AAA Battery Source
- ◆ 1/8" Stereo Input Allows up to 2 Vrms Signals
- ◆ On-Board MIC
- ◆ 1/8" Stereo Headphone Output Jack
- ◆ S/PDIF Input (CS8416 Receiver)
- ◆ Flexible User Interface
 - 2 Pushbuttons Enable, Disable and Navigate between Reset, Standby, Input Source and Effects Options
 - 2 Pushbuttons Adjust Volume and Effects

CRD42L51 Actual Size

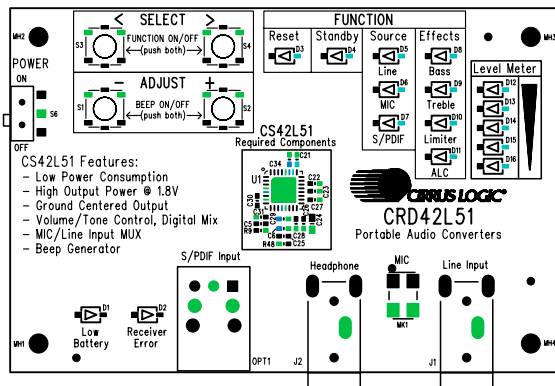

Description

The CRD42L51 evaluation board provides a quick and easy evaluation of select features in the CS42L51 Low Power, Stereo CODEC. Four pushbuttons and sixteen LED's comprise the user interface, allowing manipulation of the CS42L51's registers and control clock/data routing between the CODEC, crystal oscillator, and S/PDIF Receiver.

Two 1/8" stereo jacks provide analog input and output connections, and a S/PDIF optical receiver provides a digital input connection. An on-board microphone demonstrates the high dynamic range of the CS42L51's Programmable Gain Amplifier (PGA) and MIC pre-amplifier.

Power is derived from a single AAA battery boosted up to 3.3 V for the interface and control logic, then regulated down to 1.8 V for the CS42L51's analog/digital core and headphone supply.

The CRD42L51 highlights the ultra small layout required for the CS42L51. Required components include only a few small ceramic capacitors and resistors.

ORDERING INFORMATION

CRD42L51

Reference Design

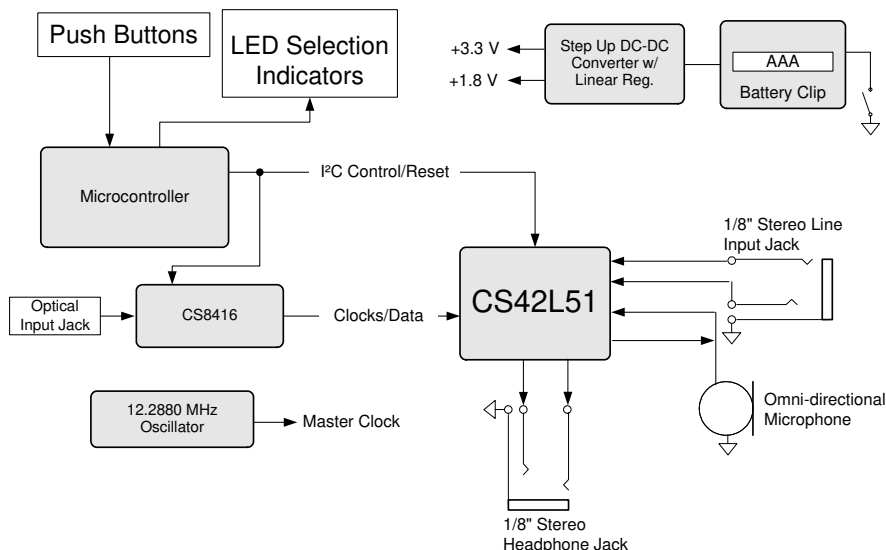

TABLE OF CONTENTS

1. QUICK-START GUIDE	3
2. FUNCTION & LEVEL DETAILS	4
3. SYSTEM OVERVIEW	5
3.1 Power (U2)	5
3.2 Microcontroller (U5)	5
3.3 CS42L51 Audio CODEC (U1)	5
3.4 CS8416 Digital Audio Receiver (U4)	5
3.5 Oscillator (Y1)	5
3.6 Analog Input	5
3.7 Analog Outputs	5
3.8 Switch & Pushbutton	6
3.9 LEDs	6
3.10 Error Indicators	6
3.11 Layout	6
4. SYSTEM CONNECTIONS & INTERFACE	7
5. CRD42L51 SCHEMATICS	9
6. CRD42L51 LAYOUT	13
7. REVISION HISTORY	19

LIST OF FIGURES

Figure 1. Block Diagram.....	8
Figure 2. CS42L51 and Analog I/O (Schematic Sheet 1)	9
Figure 3. S/PDIF Input (Schematic Sheet 2).....	10
Figure 4. Microcontroller, Pushbuttons and LED Indicators (Schematic Sheet 3)	11
Figure 5. DC-DC Converter and AAA Battery Clip (Schematic Sheet 4)	12
Figure 6. Silk Screen Top.....	13
Figure 7. Silk Screen Bottom	14
Figure 8. Top-Side Layer	15
Figure 9. Internal Layer (Ground Plane)	16
Figure 10. Internal Layer (Power Plane)	17
Figure 11. Bottom-Side Layer	18

1. QUICK-START GUIDE

4. Push both SELECT buttons simultaneously to turn off the Reset function.
The board will enter Standby for a moment and then automatically activate the Line function.

5. Use any one of the SELECT buttons to navigate between and shift the focus to select functions.
To turn selected functions on or off, push both SELECT buttons simultaneously. The associated LED will turn on or off.

3. Switch the power switch to the ON position. (NOTE: 1 AAA battery, installed on the back side, is required.) The Reset Function will activate. No selections or adjustments can be made while Reset is on.

6. Use any one of the ADJUST buttons to control the volume/ threshold level of each Source/Effects that receives focus.
The Level Meter will briefly display a pre-defined gradient that represents the volume/ threshold level in dBs. The optimal/default level flashes for a few seconds.

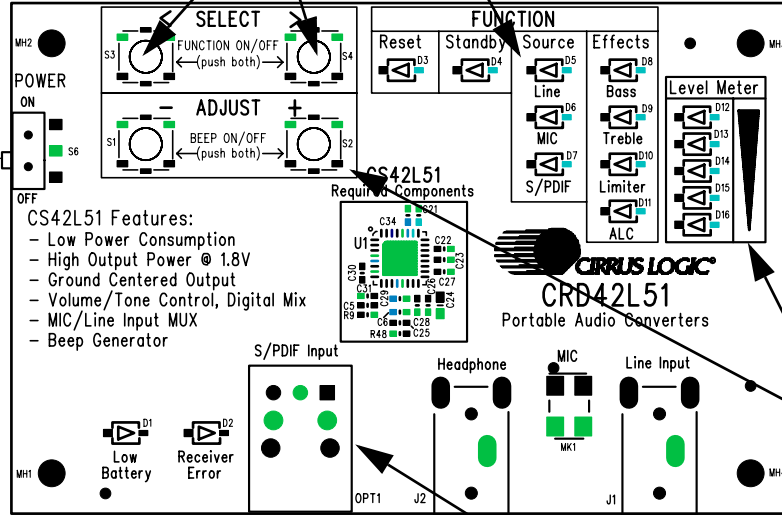

1. Begin by connecting 16 Ω or 32 Ω headphones.

2. Connect the desired interface. Apply up to 2 Vrms to the Line Input. For smaller signals, enable the ALC function for automatic level control (up to +12 dB analog gain). For digital source, connect optical cable to S/PDIF Input

7. Speak into the microphone or activate the external S/PDIF or Line player to begin evaluation.

Pushbutton Control	Key Press	Description
SELECT	< (only)	Left/Up Navigation - Shifts the focus between functions. A blinking LED indicates which function has received focus.
	> (only)	Right/Down Navigation - Shifts the focus between functions. A blinking LED indicates which function has received focus.
	< AND > (simultaneously)	Enables/Disables the function that is in-focus. When the selected function is enabled AND in-focus, the associated LED blinks ON, periodically, with a longer duty cycle.
ADJUST	- (only)	Decreases the volume level of the function that is in-focus. Increases the threshold level of the ALC/Limiter when either is in-focus.
	+ (only)	Increases the volume level of the function that is in-focus. Decreases the threshold level of the ALC/Limiter when either is in-focus.
	- AND + (simultaneously)	Enables/Disables confirmation/error beeps.

2. FUNCTION & LEVEL DETAILS

Function	State/LED Illumination	Description
Reset	ON	CS42L51, CS8416, optical receiver, oscillator held in reset and disabled.
	OFF	CS42L51, oscillator out of reset. CS8416 and optical receiver controlled by S/PDIF function. The Line function is enabled automatically.
Standby	ON	CS8416, optical receiver, oscillator held in reset and disabled; CS42L51 soft powered down.
	OFF	All devices out of reset; CS42L51 powered up, register settings restored.
Line	ON	Stereo Line Input selected, unmuted; MIC powered down.
	OFF	Stereo Line Input muted.
MIC	ON	Mono MIC selected, powered up, unmuted; Line disabled.
	OFF	MIC muted.
S/PDIF	ON	S/PDIF Input selected, unmuted; CS8416 and optical receiver powered up. (Line or MIC mixed with S/PDIF if enabled.)
	OFF	S/PDIF Input muted; CS8416 and optical receiver powered down.
Bass	ON	Tone Control enabled, Bass corner frequency set to 200 Hz, Treble corner frequency set to 7 kHz.
	OFF	Tone Control (Bass and Treble) disabled.
Treble	ON	Tone Control enabled, Bass corner frequency set to 200 Hz, Treble corner frequency set to 7 kHz.
	OFF	Tone Control (Bass and Treble) disabled.
Limiter	ON	Limiter enabled, attack rate set to 0x02, release rate set to 0x3D.
	OFF	Limiter disabled.
ALC	ON	ALC enabled, attack rate set to 0x02, release rate set to 0x3D.
	OFF	ALC disabled.

Level Meter (LED Luminosity)	Level (dB)			ALC/Limiter Threshold (dB)	
	Line/SPDIF	MIC	Bass/Treble	MAX	MIN/Cushion
LED12_ON	+6.0	+44.0	+12.0	-18.0	-24.0
LED12_75%	+4.0	+42.5	+10.5	-	-
LED12_50%	+2.0	+41.0	-	-	-
LED12_25%	+0.0	+39.5	+9.0	-	-
LED13_ON	-1.5	+38.0	+7.5	-12.0	-18.0
LED13_75%	-3.0	+36.5	+6.0	-	-
LED13_50%	-4.5	+35.0	-	-	-
LED13_25%	-6.0 (default)	+33.5	+4.5	-	-
LED14_ON	-7.5	+32.0 (default)	+3.0	-9.0	-12.0
LED14_75%	-9.0	+30.5	+1.5	-	-
LED14_50%	-11.0	+29.0	-	-	-
LED14_25%	-13.0	+27.5	+0.0 (default)	-	-
LED15_ON	-16.0	+26.0	-1.5	-6.0 (default)	-9.0 (default)
LED15_75%	-19.0	+24.5	-3.0	-	-
LED15_50%	-22.0	+23.0	-	-	-
LED15_25%	-26.0	+21.5	-4.5	-	-
LED16_ON	-30.0	+20.0	-6.0	-3.0	-6.0
LED16_75%	-35.0	+18.5	-7.5	-	-
LED16_50%	-40.0	+17.0	-	-	-
LED16_25%	-45.0	+15.5	-9.0	-	-
LED16_OFF	-51.5	+14.0	-10.5	+0.0	-3.0

3. SYSTEM OVERVIEW

The CRD42L51 reference design provides a quick and general overview of the features in the CS42L51 CODEC and provides a reference of an ultra small layout design. Line, MIC and S/PDIF sources are accommodated, and a microcontroller automatically configures the board and the CODEC's internal registers for straightforward operation.

The CRD42L51 schematic-set has been partitioned into four pages and is shown in [Figures 2](#) through [5](#).

3.1 Power (U2)

Power is supplied to the board through a single AAA battery. A DC-DC Converter boosts the battery's voltage to 3.3 V which is then regulated down to 1.8 V. The CS42L51 is powered from 1.8 V, demonstrating its internal ground-centered amplifier's ability to deliver ample power into headphone loads even at low supply voltages. The interface logic between the CS8416, oscillator and CS42L51 operates at 3.3 V.

3.2 Microcontroller (U5)

The microcontroller controls digital signal routing between the CS42L51, CS8416 and oscillator in response to user input via four pushbuttons. It automatically initializes the board to predefined settings once power is applied.

3.3 CS42L51 Audio CODEC (U1)

A complete description of the CS42L51 ([Figure 2 on page 9](#)) is included in the CS42L51 product data sheet. The CS42L51 is automatically configured by the microcontroller to the default settings following a power-on condition and later modified based on user input via four pushbuttons. See [Section 2](#) for a description of each functional mode and the associated configuration setting for the CS42L51.

3.4 CS8416 Digital Audio Receiver (U4)

A complete description of the CS8416 receiver ([Figure 3 on page 10](#)) and a discussion of the digital audio interface are included in the CS8416 data sheet.

The CS8416 converts the input S/PDIF data stream from the optical connector into PCM data for the CS42L51. The S/PDIF input may be mixed with the Line or MIC input. In this case, the CODEC clock source comes from the CS8416. Should the S/PDIF source become unavailable, causing a Receiver Error, the microcontroller will automatically switch the system master clock to the oscillator for uninterrupted operation of the Line or MIC input.

3.5 Oscillator (Y1)

The on-board oscillator provides the system master clock when the digital audio receiver is powered down or when a Receiver Error occurs. Selections are automatically determined based on user input and system status.

3.6 Analog Input

An 1/8" jack supplies the line-level analog inputs through an AC-coupled passive filter. Voltage dividers before the inputs to the CS42L51 allow up to 2 V_{rms} signals (NOTE: To amplify smaller signals, enable the Automatic Level Control (ALC). The CS42L51 applies up to +12 dB analog gain, as needed, using the ALC together with the integrated Programmable Gain Amplifier (PGA)). A surface-mount microphone connects to one of the inputs of the CS42L51 and is mux'd with the Line input. Either the Line or MIC input may be mixed with the S/PDIF input.

3.7 Analog Outputs

An 1/8" jack outputs the signal from the CS42L51's ground-centered headphone amplifier. The load stabilizer circuitry made up of a resistor/capacitor pair allow the amplifier to drive headphone in addition to line-level loads.

3.8 Switch & Pushbutton

The POWER switch engages the AAA battery when switched to the ON position. Power is applied to the board and the microcontroller initializes. The SELECT pushbutton switches allow the user to navigate back and forth between the FUNCTION options. When both SELECT buttons are pushed simultaneously, the state of the function that receives focus (indicated by a blinking LED) is toggled. The ADJUST buttons allow the user to apply gain, attenuation and move the threshold levels of the ALC and Limiter (the level of each is shown in the Level Meter LED's). When both ADJUST buttons are pushed simultaneously, the state of the CS42L51's internal beep generator is toggled.

3.9 LEDs

The FUNCTION LEDs provide a visual indication of which functions are presently ON (constant illumination) or OFF (no illumination) and which has received focus (periodic illumination). The Level Meter LEDs provide a visual indication of the Line, MIC, S/PDIF, Bass and Treble volume levels as well as the Limiter and ALC threshold levels (see [Section 2](#) for LED luminosity decode). When the selected function receives focus, the Level Meter LEDs are illuminated for a brief moment, reflecting the volume/threshold level, and flash when the adjustment reaches the default level.

3.10 Error Indicators

Low Battery: When the battery voltage level in the AAA battery drops below approximately 0.96 V, this LED will illuminate. Operation will continue until the level drops to approximately 0.70 V; but after a power cycle, the DC-DC converter will only start up when the level is at least 1.1 V.

Receiver Error: If the S/PDIF function is enabled and the CS8416 loses its PLL lock (triggered by unplugging the cable from the optical connector, OPT1, or turning off the S/PDIF audio source), this LED will illuminate. If the Line or MIC function is presently enabled, the CRD will automatically switch from the CS8416's master clock to the on-board oscillator and configure the CS42L51 accordingly for uninterrupted operation of the Line or MIC input.

3.11 Layout

The CS42L51 requires only a minimal set of components to achieve specified performance results. Its integrated ground-centered amplifier eliminates the need for bulky DC-blocking capacitors and only requires two tiny ceramic capacitors for the charge pump. Additional components include load-stabilization circuitry and power supply decoupling. See the CS42L51 data sheet for further details.

[Figure 1 on page 8](#) provides an overview of the connections to the CS42L51. [Figure 6 on page 13](#) and [Figure 7 on page 14](#) show the component placement. [Figure 8 on page 15](#) shows the top layout; [Figure 9 on page 16](#) and [Figure 10 on page 17](#) show the inner layers, and [Figure 11 on page 18](#) shows the bottom layout. The decoupling capacitors are located as close to the CS42L51 as possible. Extensive use of ground plane fill in the reference design yields large reductions in radiated noise.

4. SYSTEM CONNECTIONS & INTERFACE

Connector/ Interface	Reference Designator	Input/Output	Description
AAA	BT1	Input	Battery Power Supply.
< SELECT	S3	Input	Pushbutton for navigating to the left or upwards. On/Off (function enable/disable) control when pushed simultaneously with SELECT >.
SELECT >	S4	Input	Pushbutton for navigating to the right or downwards. On/Off (function enable/disable) control when pushed simultaneously with < SELECT.
- ADJUST	S1	Input	Pushbutton for decreasing volume levels and increasing threshold levels. On/Off (beep enable/disable) control when pushed simultaneously with ADJUST +.
ADJUST +	S2	Input	Pushbutton for increasing volume levels and decreasing threshold levels. On/Off (beep enable/disable) control when pushed simultaneously with ADJUST +.
Line Input	J1	Input	1/8" jack for analog input signal to CS42L51. Up to 2 Vrms signals allowed.
MIC	MK1	Input	Microphone for analog input signal to CS42L51.
Headphone	J2	Output	Headphone or Line-level jack for analog outputs.
S/PDIF IN	OPT1	Input	CS8416 digital audio input via optical cable.

CRD42L51 BLOCK DIAGRAM

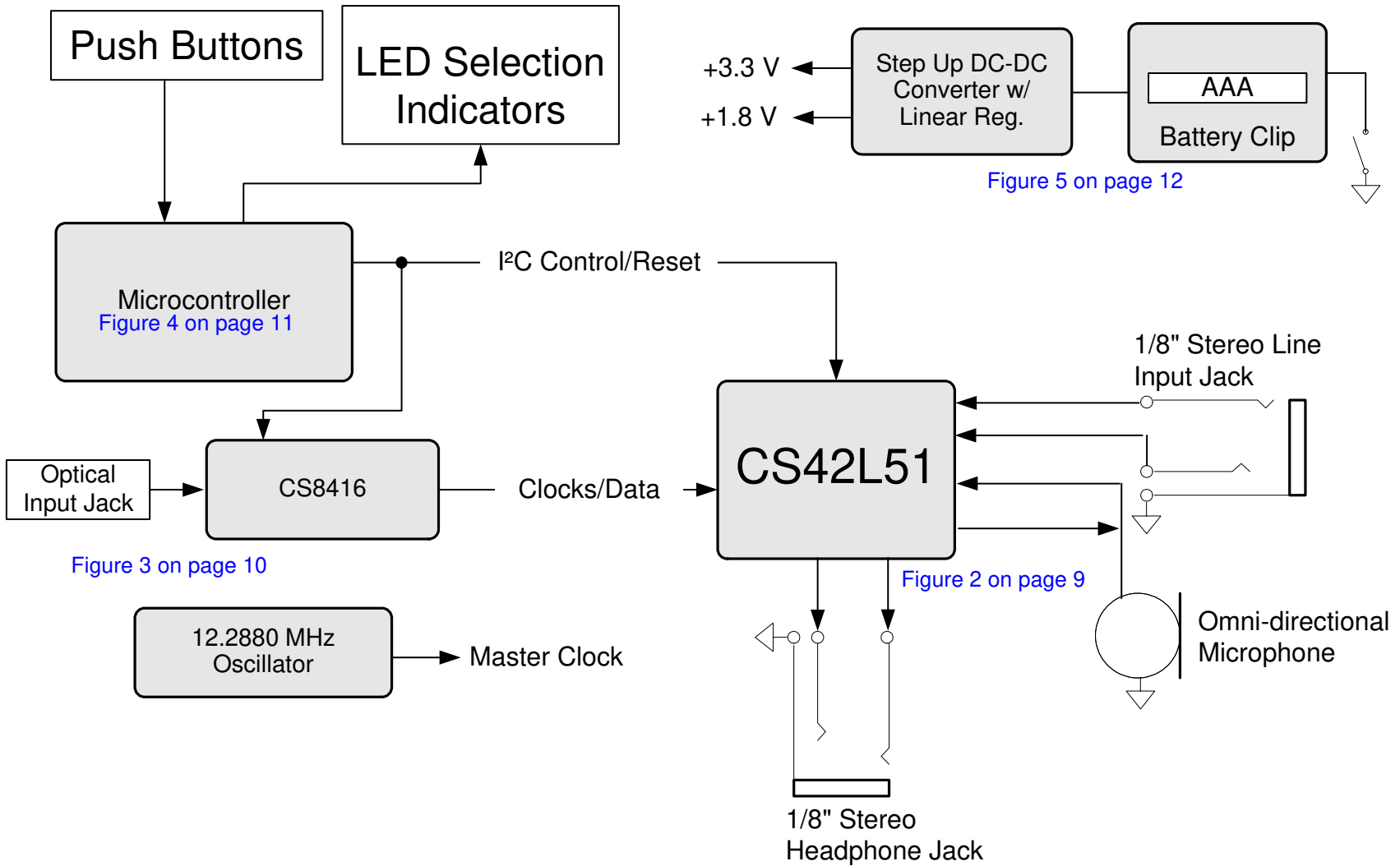
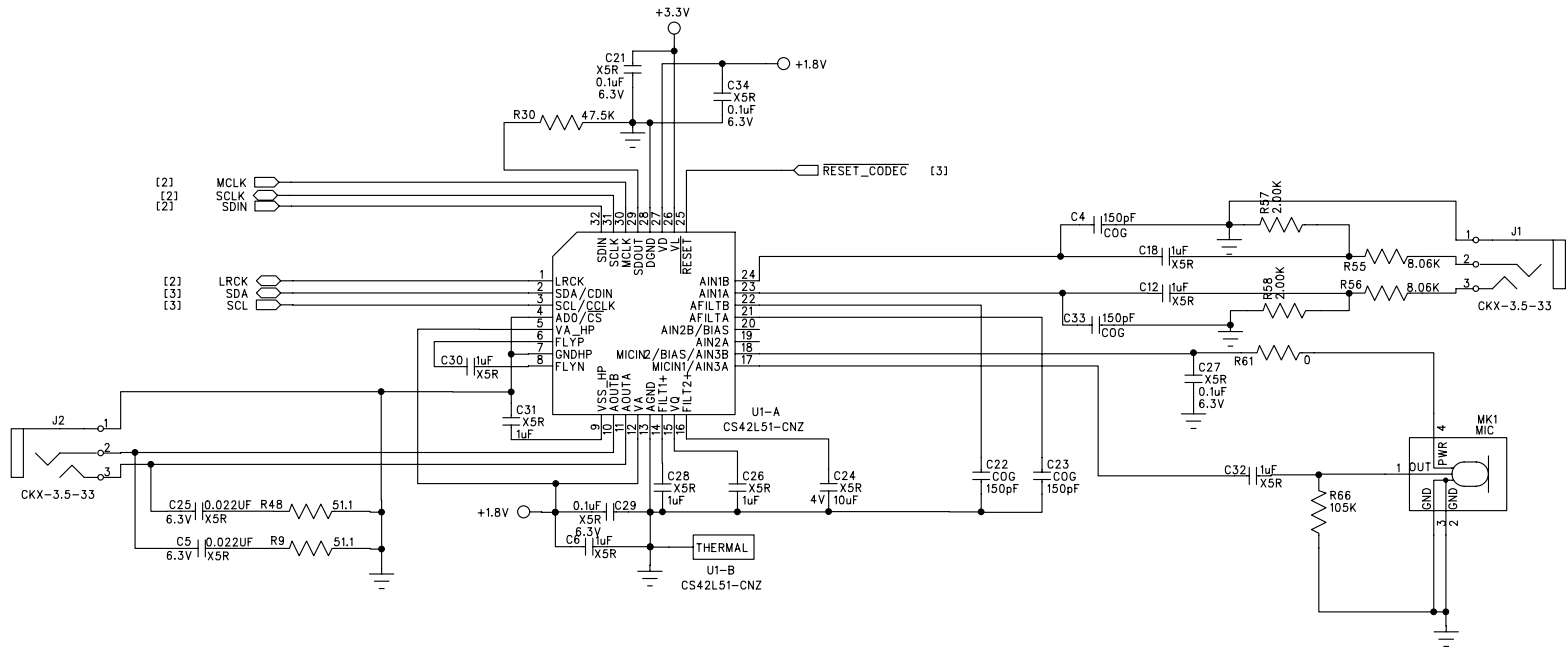

Figure 1. Block Diagram



5. CRD42L51 SCHEMATICS



NOTES: UNLESS OTHERWISE SPECIFIED;
 1. ALL RESISTOR VALUES ARE IN OHMS.

Figure 2. CS42L51 and Analog I/O (Schematic Sheet 1)



CIRRUS LOGIC

CRD42L51

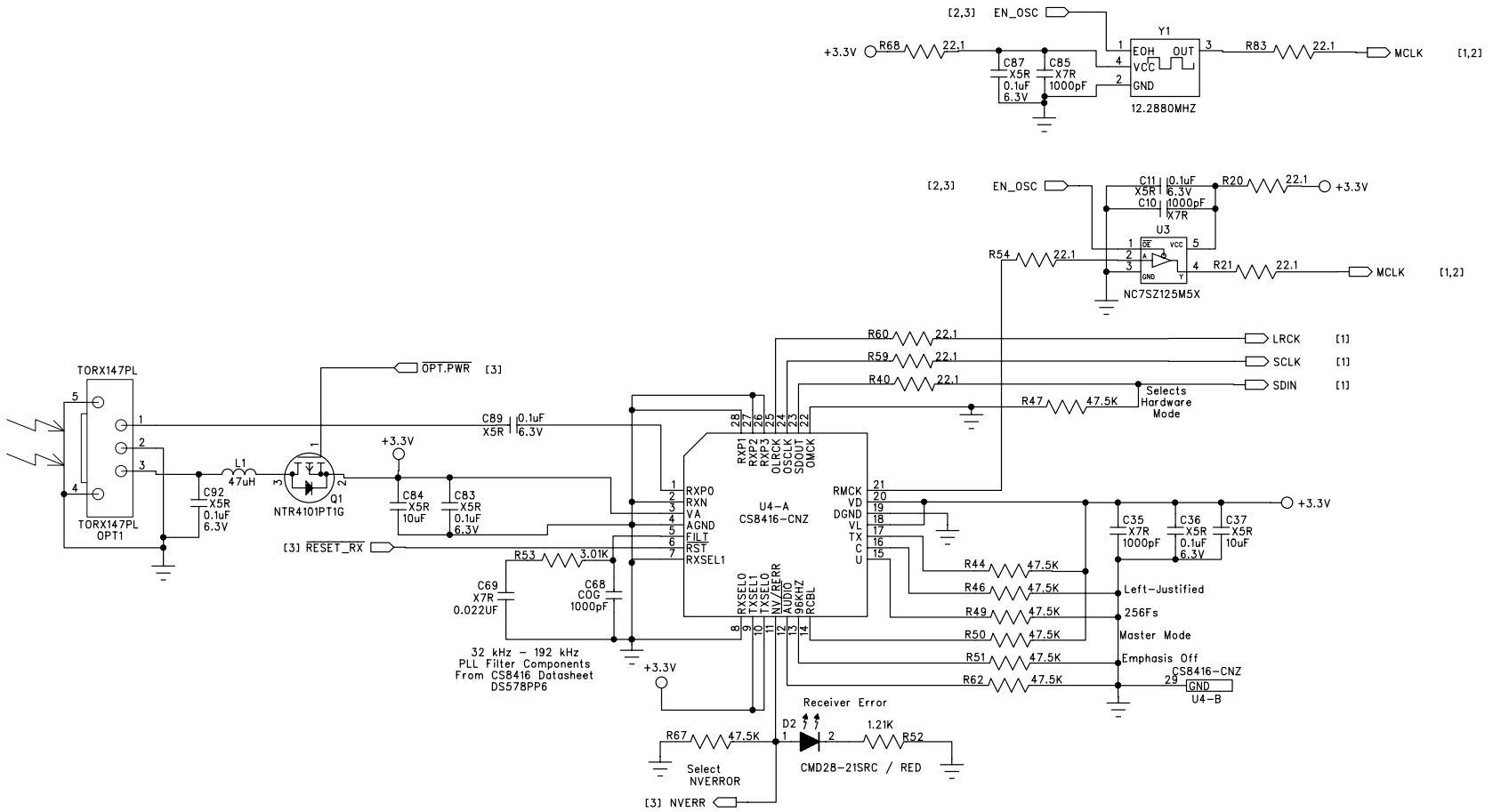

Figure 3. S/PDIF Input (Schematic Sheet 2)



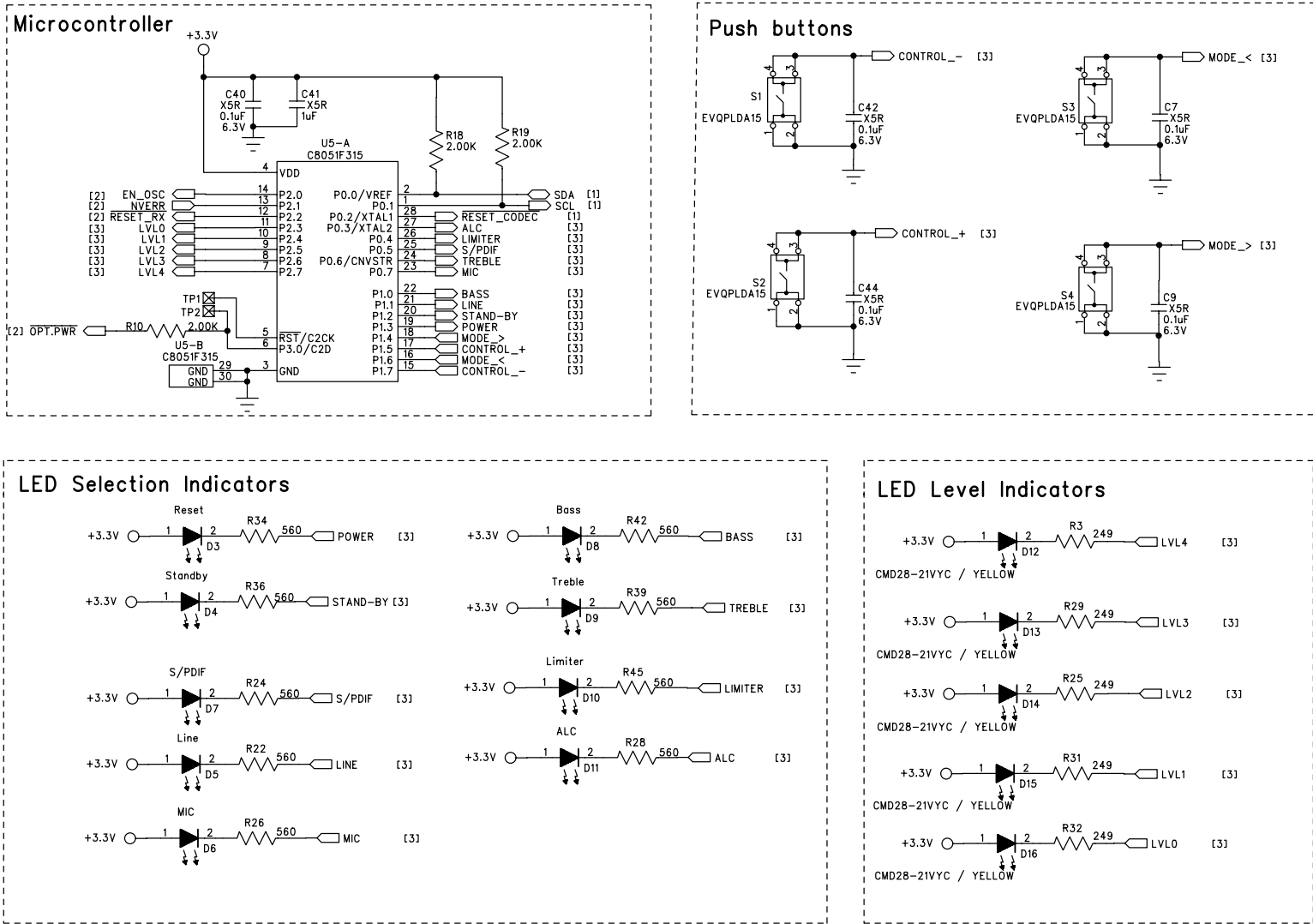
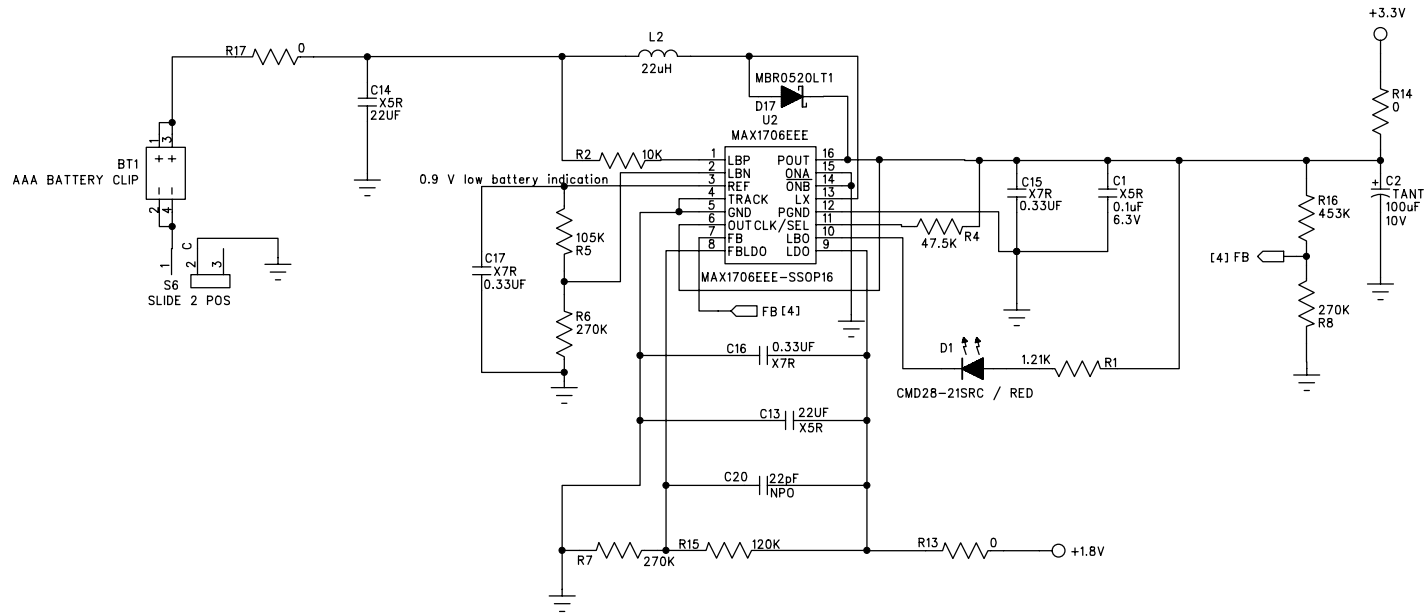

Figure 4. Microcontroller, Pushbuttons and LED Indicators (Schematic Sheet 3)



STANDOFFS

- ⊗ MH1
- ⊗ MH2
- ⊗ MH3
- ⊗ MH4

Figure 5. DC-DC Converter and AAA Battery Clip (Schematic Sheet 4)



CIRUS LOGIC

6. CRD42L51 LAYOUT

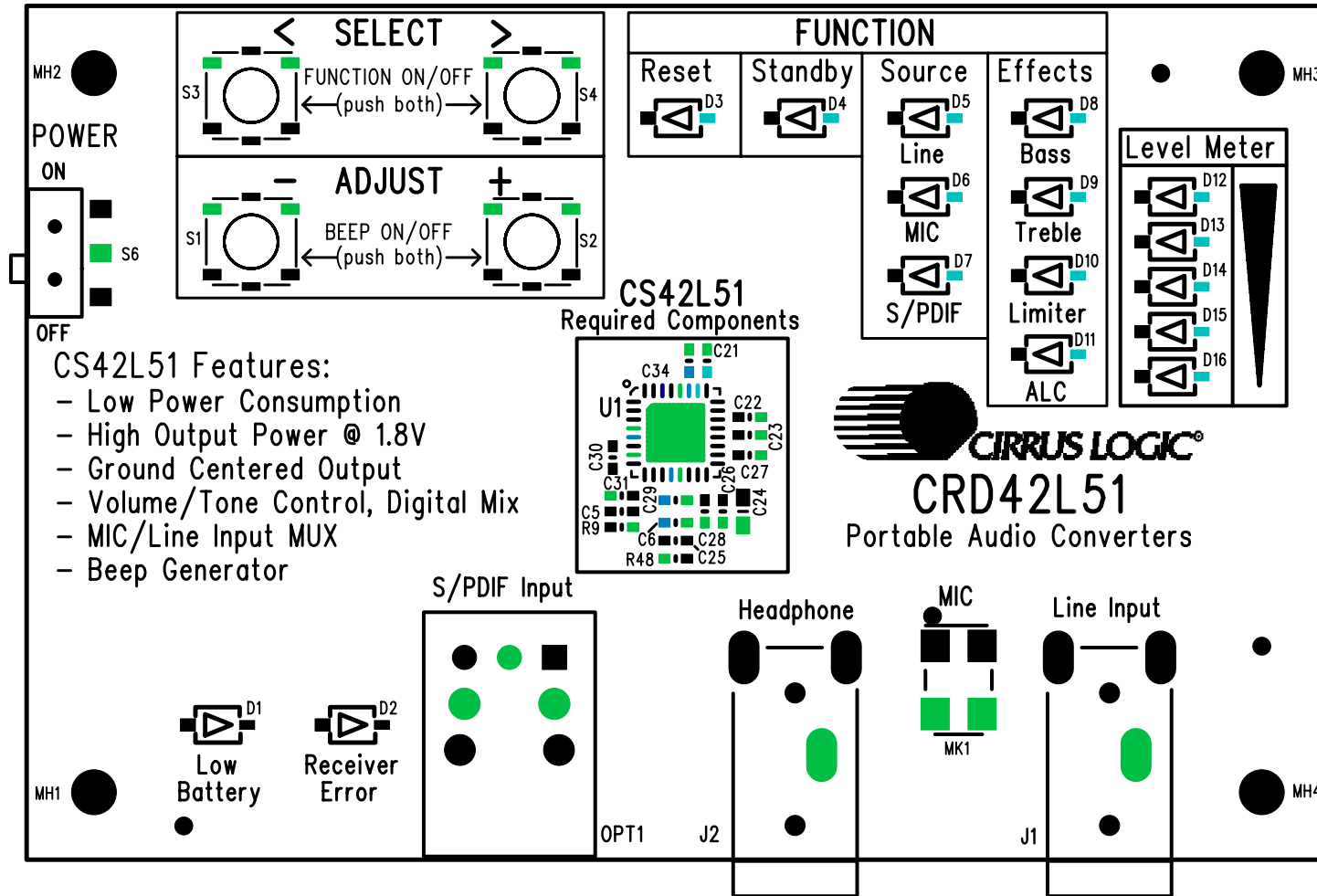

Figure 6. Silk Screen Top

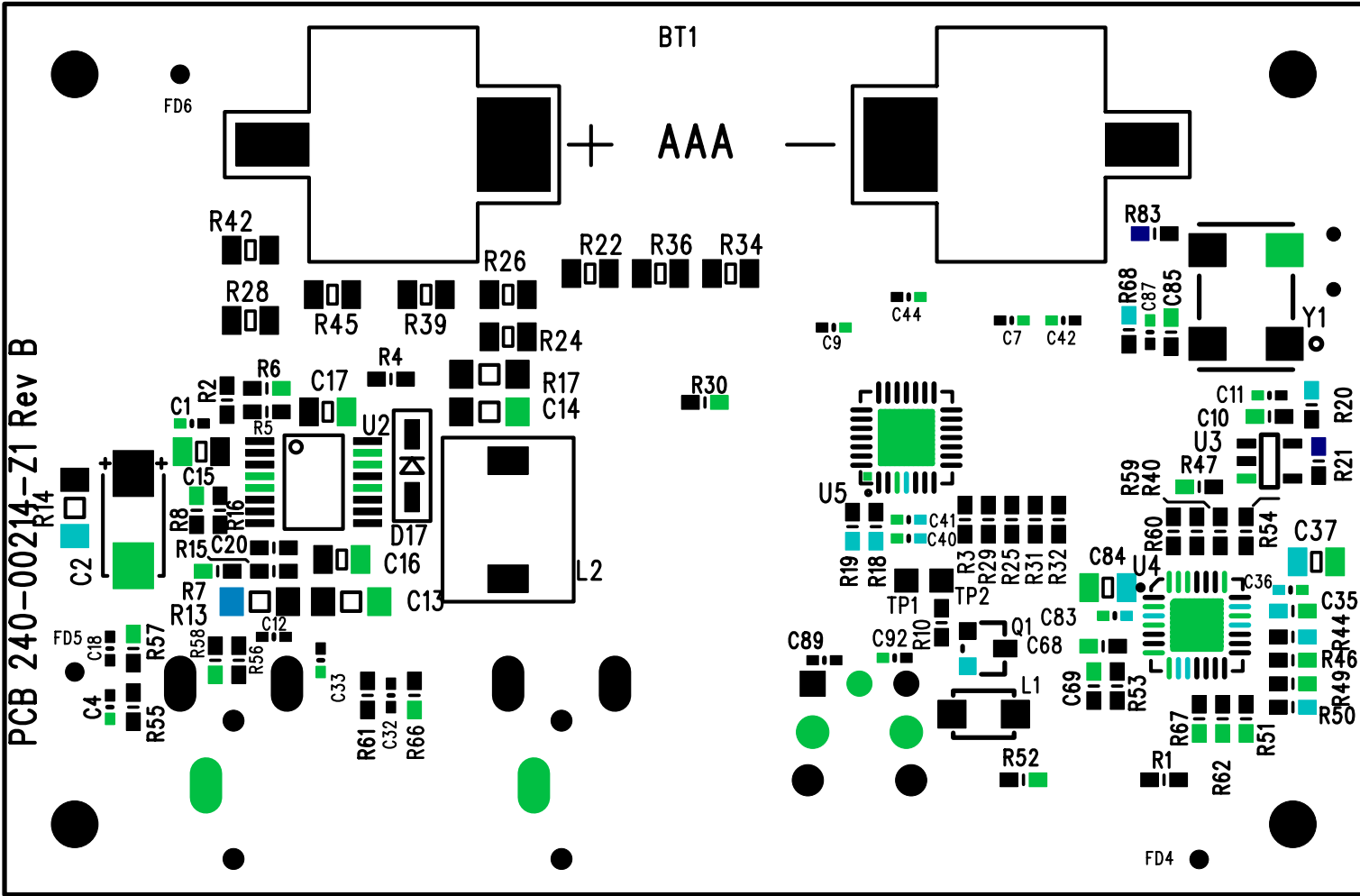

Figure 7. Silk Screen Bottom

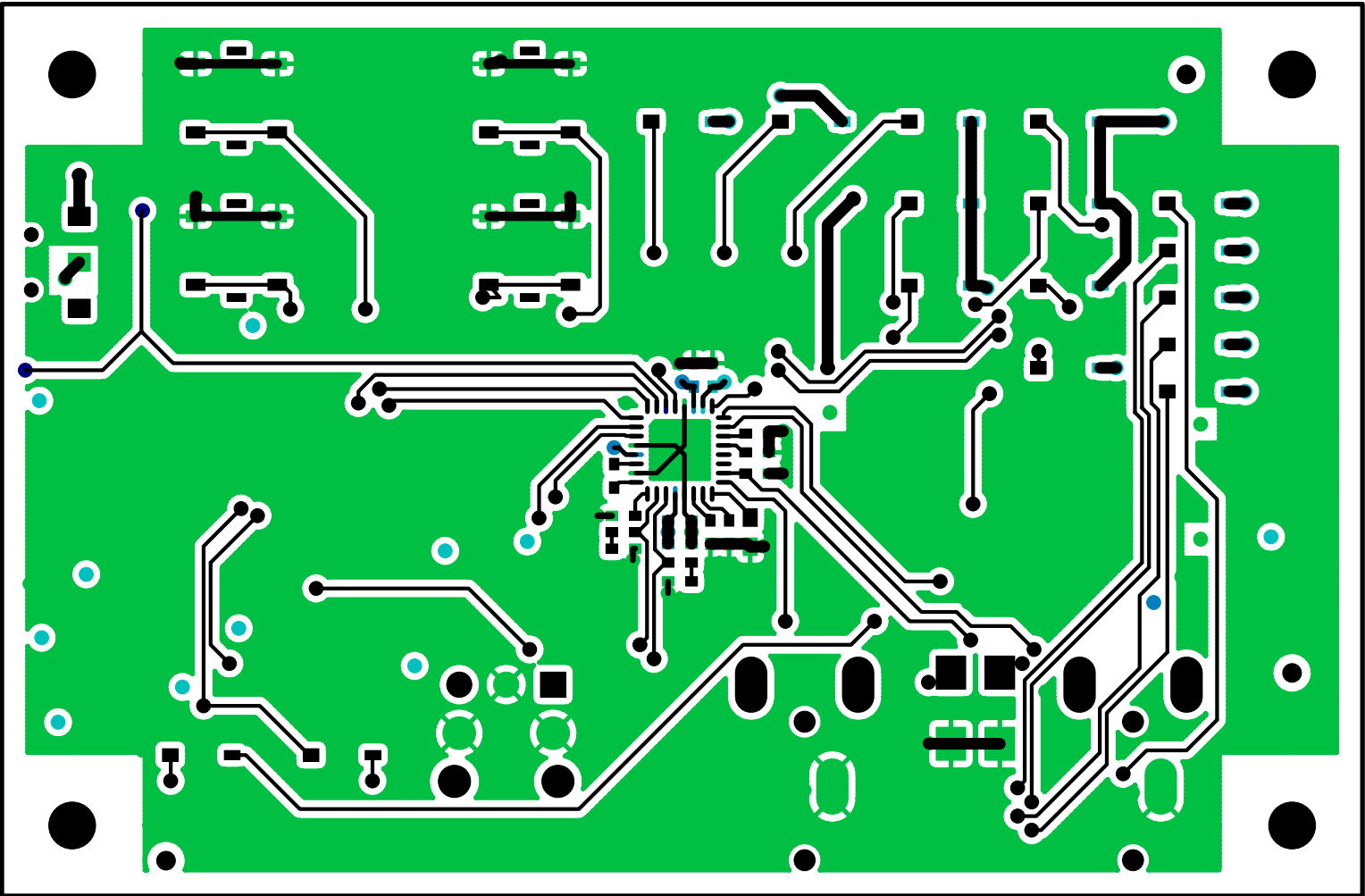

Figure 8. Top-Side Layer

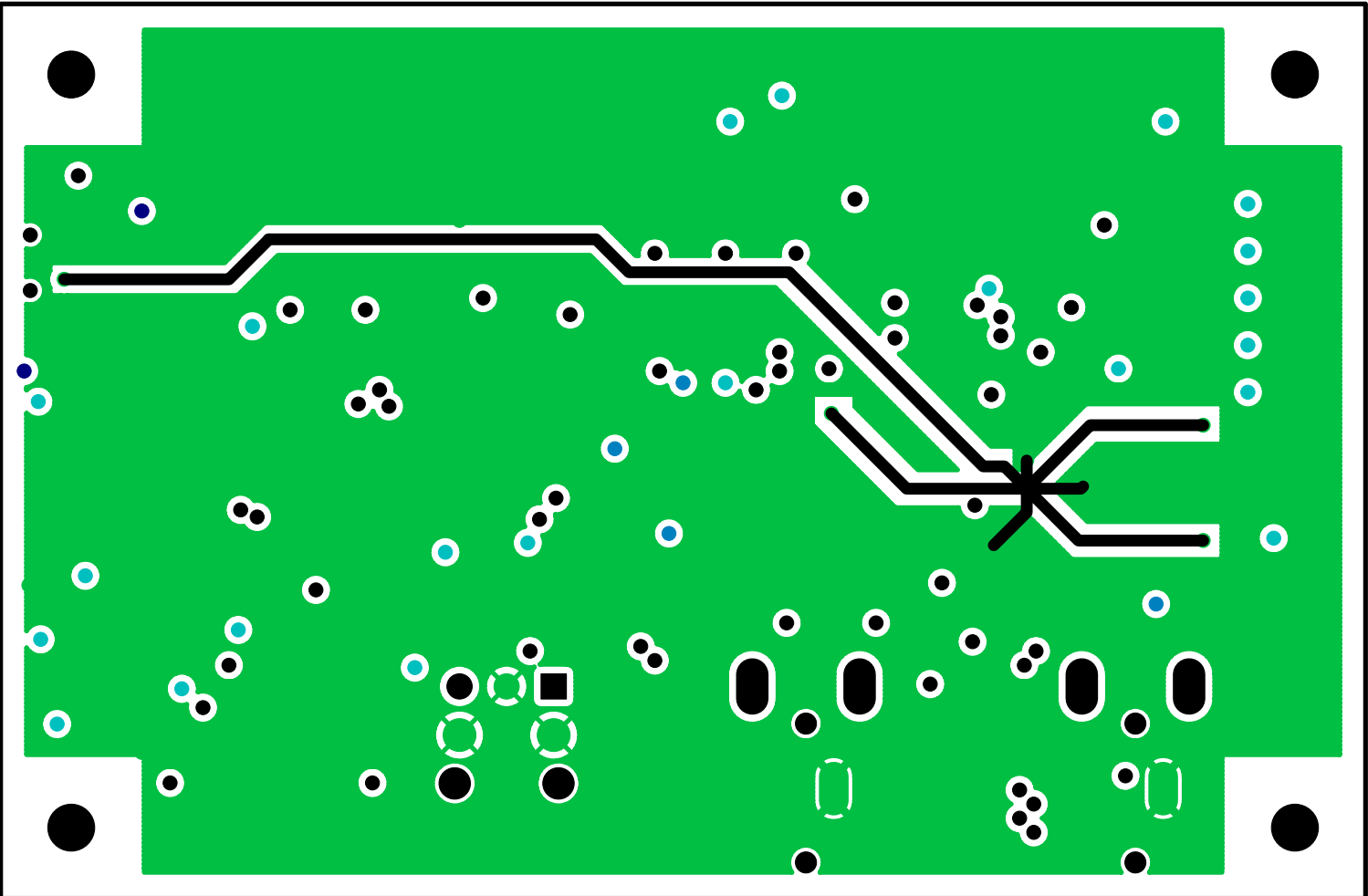

Figure 9. Internal Layer (Ground Plane)

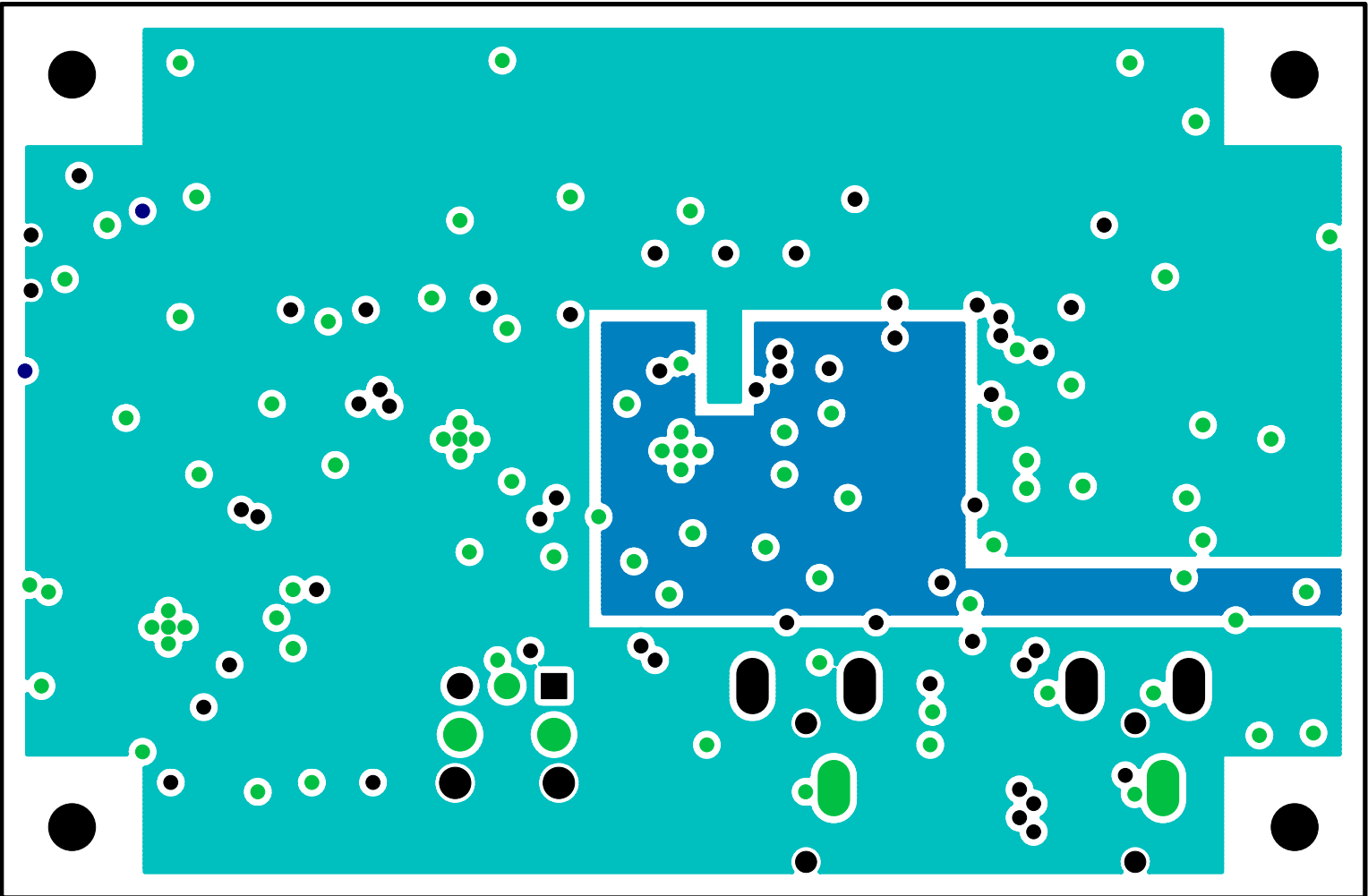

Figure 10. Internal Layer (Power Plane)

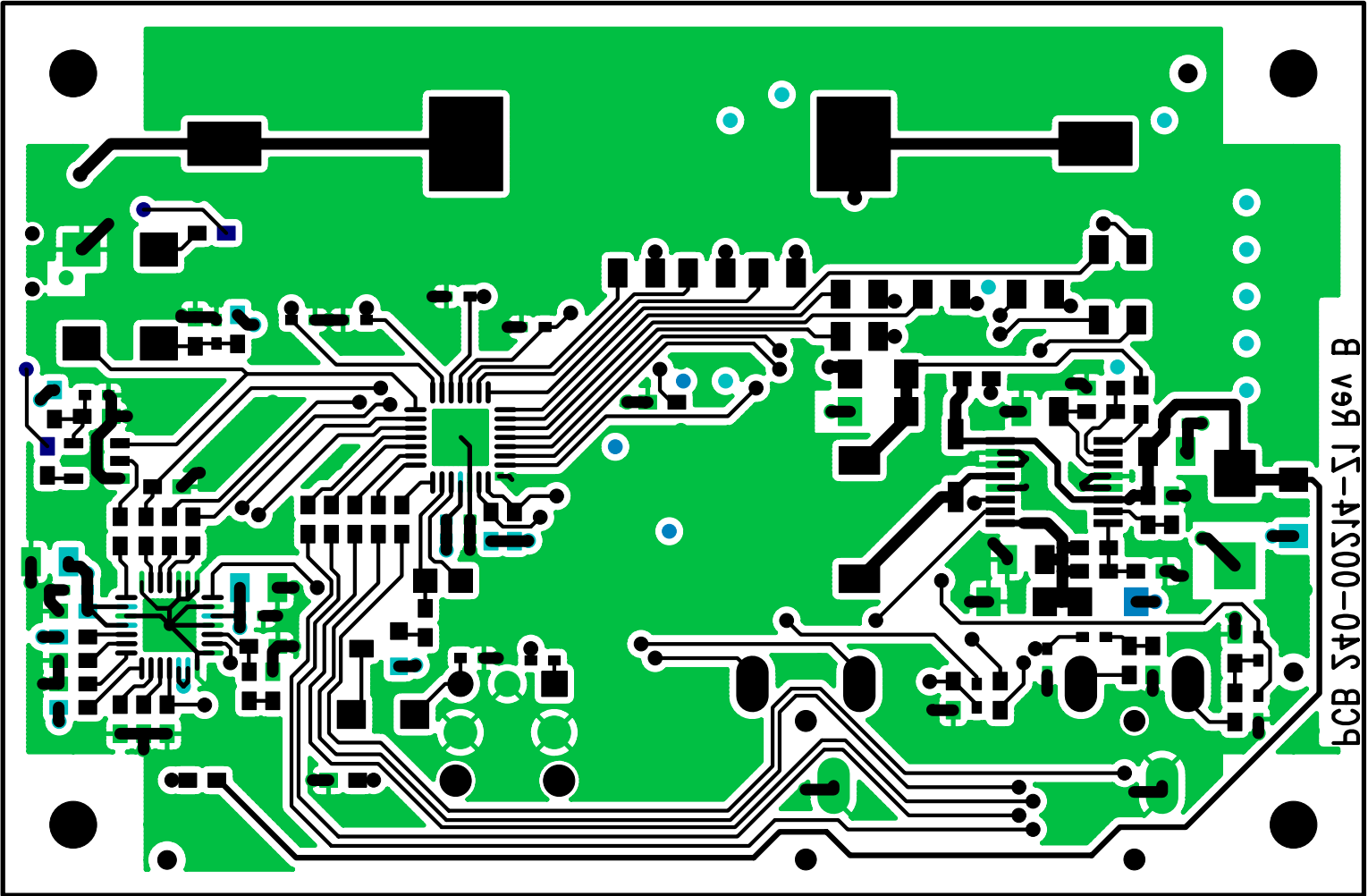

Figure 11. Bottom-Side Layer

7. REVISION HISTORY

Release	Changes
RD1	Initial Release

Contacting Cirrus Logic Support

For all product questions and inquiries contact a Cirrus Logic Sales Representative.

To find the one nearest to you go to www.cirrus.com/corporate/contacts/sales.cfm

IMPORTANT NOTICE

Cirrus Logic, Inc. and its subsidiaries ("Cirrus") believe that the information contained in this document is accurate and reliable. However, the information is subject to change without notice and is provided "AS IS" without warranty of any kind (express or implied). Customers are advised to obtain the latest version of relevant information to verify, before placing orders, that information being relied on is current and complete. All products are sold subject to the terms and conditions of sale supplied at the time of order acknowledgment, including those pertaining to warranty, indemnification, and limitation of liability. No responsibility is assumed by Cirrus for the use of this information, including use of this information as the basis for manufacture or sale of any items, or for infringement of patents or other rights of third parties. This document is the property of Cirrus and by furnishing this information, Cirrus grants no license, express or implied under any patents, mask work rights, copyrights, trademarks, trade secrets or other intellectual property rights. Cirrus owns the copyrights associated with the information contained herein and gives consent for copies to be made of the information only for use within your organization with respect to Cirrus integrated circuits or other products of Cirrus. This consent does not extend to other copying such as copying for general distribution, advertising or promotional purposes, or for creating any work for resale.

CERTAIN APPLICATIONS USING SEMICONDUCTOR PRODUCTS MAY INVOLVE POTENTIAL RISKS OF DEATH, PERSONAL INJURY, OR SEVERE PROPERTY OR ENVIRONMENTAL DAMAGE ("CRITICAL APPLICATIONS"). CIRRUS PRODUCTS ARE NOT DESIGNED, AUTHORIZED OR WARRANTED FOR USE IN AIRCRAFT SYSTEMS, MILITARY APPLICATIONS, PRODUCTS SURGICALLY IMPLANTED INTO THE BODY, AUTOMOTIVE SAFETY OR SECURITY DEVICES, LIFE SUPPORT PRODUCTS OR OTHER CRITICAL APPLICATIONS. INCLUSION OF CIRRUS PRODUCTS IN SUCH APPLICATIONS IS UNDERSTOOD TO BE FULLY AT THE CUSTOMER'S RISK AND CIRRUS DISCLAIMS AND MAKES NO WARRANTY, EXPRESS, STATUTORY OR IMPLIED, INCLUDING THE IMPLIED WARRANTIES OF MERCHANTABILITY AND FITNESS FOR PARTICULAR PURPOSE, WITH REGARD TO ANY CIRRUS PRODUCT THAT IS USED IN SUCH A MANNER. IF THE CUSTOMER OR CUSTOMER'S CUSTOMER USES OR PERMITS THE USE OF CIRRUS PRODUCTS IN CRITICAL APPLICATIONS, CUSTOMER AGREES, BY SUCH USE, TO FULLY INDEMNIFY CIRRUS, ITS OFFICERS, DIRECTORS, EMPLOYEES, DISTRIBUTORS AND OTHER AGENTS FROM ANY AND ALL LIABILITY, INCLUDING ATTORNEYS' FEES AND COSTS, THAT MAY RESULT FROM OR ARISE IN CONNECTION WITH THESE USES.

Cirrus Logic, Cirrus, and the Cirrus Logic logo designs are trademarks of Cirrus Logic, Inc. All other brand and product names in this document may be trademarks or service marks of their respective owners.