



Chipsmall Limited consists of a professional team with an average of over 10 year of expertise in the distribution of electronic components. Based in Hongkong, we have already established firm and mutual-benefit business relationships with customers from,Europe,America and south Asia,supplying obsolete and hard-to-find components to meet their specific needs.

With the principle of “Quality Parts,Customers Priority,Honest Operation,and Considerate Service”,our business mainly focus on the distribution of electronic components. Line cards we deal with include Microchip,ALPS,ROHM,Xilinx,Pulse,ON,Everlight and Freescale. Main products comprise IC,Modules,Potentiometer,IC Socket,Relay,Connector.Our parts cover such applications as commercial,industrial, and automotives areas.

We are looking forward to setting up business relationship with you and hope to provide you with the best service and solution. Let us make a better world for our industry!



Contact us

Tel: +86-755-8981 8866 Fax: +86-755-8427 6832

Email & Skype: info@chipsmall.com Web: www.chipsmall.com

Address: A1208, Overseas Decoration Building, #122 Zhenhua RD., Futian, Shenzhen, China



Stereo 100 W PWM Amplifier Reference Design

Features

- Two full-bridge channels, 100 W each
- 106 dB Dynamic Range - both channels
- 0.015% THD+N at 1 W
- Power Supply Rejection (PSR) feedback allowing amplifier to operate from low cost linear unregulated power supplies
- Spread Spectrum Modulation - Reduces Modulation Energy
- Passes CISPR and FCC requirements for radiated and power line conducted emissions
- Independent peak signal limiting per channel
- Thermal and over-current protection
- > 85% amplifier efficiency
- Works with GUI to configure the board
- Demonstrates recommended layout and grounding arrangements

Description

The CRD44600-PH-FB PWM Amplifier demonstrates the CS44600, Cirrus' multi-channel pure digital PWM

controller. This reference design implements a two-channel amplifier which delivers 100 W per full-bridge channel into 8 Ω loads using a single +50 V supply (at 1% THD+N). A 155 W unregulated linear power supply is used to power the CRD44600-PH-FB.

As shown below, the CS44600 IC takes two stereo digital audio PCM inputs and converts them to PWM outputs. This 64-pin LQFP PWM controller provides an integrated sample rate converter for 32 kHz-192 kHz input sample rate support, volume up/down, speaker load compensation, peak limiting to prevent amplifier clipping, power supply ripple compensation, and AM frequency interference elimination.

This reference design uses the the Philips TDA8939, an integrated power stage back end for digital amplifiers (two TDA8939 parts configured as full-bridges are used for this two-channel design). Current limiting and thermal protection are provided by the TDA8939.

The inductor/capacitor 2nd order low pass filter (LPF) removes high frequency components from the output signal effectively converting it from digital to analog.

ORDERING INFORMATION

CRD44600-PH-FB

Reference Design

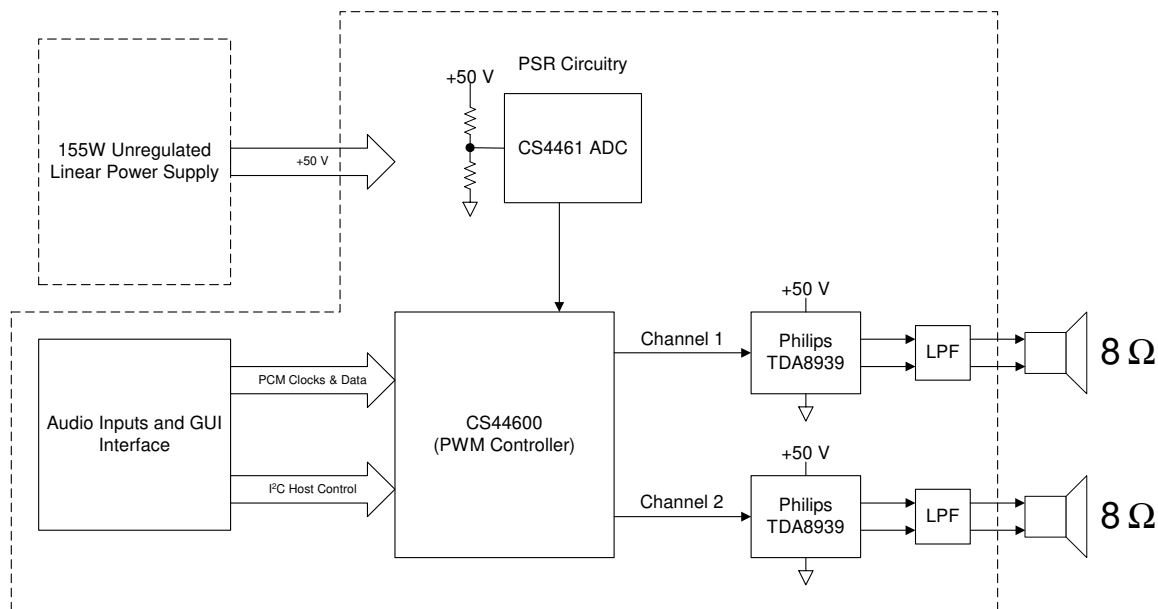

TABLE OF CONTENTS

1. SYSTEM OVERVIEW	3
1.1 CS44600 PWM Modulator	3
1.2 CS4461 PSR Feedback ADC	3
1.3 TDA8939 Power Stage	3
1.4 CS8416 Digital Audio Receiver	3
1.5 CS5341 Analog to Digital Converter	3
1.6 Control Port Interface and GUI	4
1.7 Unregulated Linear Power Supply	4
2. GUI CONTROL	5
2.1 CS44600 Dialog Tab	5
2.2 Advanced Register Debug Tab	6
3. POWER SUPPLY	8
3.1 Power Supply Ratings	8
3.2 Power Supply Decoupling	8
4. ELECTROMAGNETIC INTERFERENCE (EMI)	9
4.1 Suppression of EMI at the Source	9
4.2 EMI Testing	9
5. CRD44600-PH-FB SCHEMATICS	14
6. CRD44600-PH-FB POWER SUPPLY SCHEMATICS	19
7. CRD44600-PH-FB LAYOUT	20
8. CRD44600-PH-FB BILL OF MATERIALS	23
9. TYPICAL PERFORMANCE PLOTS	25
10. REVISION HISTORY	30

LIST OF FIGURES

Figure 1. CS44600 Dialog Tab.....	5
Figure 2. Advanced Register Debug Tab - CS44600.....	6
Figure 3. Advanced Register Debug Tab - CS8416.....	7
Figure 4. EMI Testing Setup.....	11
Figure 5. EMI Testing Setup, Close-up	11
Figure 6. Radiated EMI Testing Results- 30 MHz to 200 MHz.....	12
Figure 7. Radiated EMI Testing Results- 200 MHz to 1 GHz.....	12
Figure 8. Conducted Power Line Testing Results	13
Figure 9. Audio Inputs	14
Figure 10. CS44600	15
Figure 11. PSR Feedback.....	16
Figure 12. Left/Right Channels.....	17
Figure 13. Control Port and Power.....	18
Figure 14. Power Supply	19
Figure 15. Silk Screen Top.....	20
Figure 16. Topside Layer	21
Figure 17. Bottomside Layer	22
Figure 18. Frequency Response	25
Figure 19. THD+N vs. Frequency at 1 W, 10 W, and 50 W	26
Figure 20. THD+N vs. Power at 1 kHz	27
Figure 21. FFT at -60 dBFS and 1 kHz	28
Figure 22. FFT at -1 dBFS and 1 kHz. Red = PSR Feedback Off. Blue = PSR Feedback On	29

LIST OF TABLES

Table 1. Bill of Materials.....	23
Table 2. Revision History	30

1. SYSTEM OVERVIEW

The CRD44600-PH-FB reference design is an excellent means for evaluating the CS44600 six-channel Class-D PWM modulator. It incorporates a digital Class-D PWM modulator, two full-bridge power stages, and power supply rejection (PSR) circuitry, all on a two-layer board.

The CRD44600-PH-FB schematic set is shown in Figures 9 through 13 and the board layout is shown in Figures 15 through 17.

1.1 CS44600 PWM Modulator

A complete description of the CS44600 is included in the CS44600 product data sheet.

The CS44600 converts linear PCM data to pulse width modulated (PWM) output. It uses a Sample Rate Converter (SRC) to eliminate serial audio interface jitter effects and maintains a constant PWM switch rate of 384 kHz, resulting in high-quality sound output.

PCM data and clocks are input from either the CS8416 (S/PDIF Receiver), CS5341 (Stereo ADC), or J19 (PCM Input Header).

1.2 CS4461 PSR Feedback ADC

A complete description of the CS4461 is included in the CS4461 product data sheet.

The CS4461 is connected to the CS44600 to provide power supply rejection (PSR) for the VP supply voltage connected to J17. Resistors R41 and R42 are set for VP = +50 V. See the CS4461 data sheet for equations to determine the resistor values.

1.3 TDA8939 Power Stage

A complete description of the Philips TDA8939 is included in the TDA8939 product data sheet.

The TDA8939 is a high-voltage PWM amplifier power stage. It integrates two half-bridge drivers and fault protection. For the CRD44600-PH-FB, each of the two TDA8939's are configured as full-bridges. Care should be taken to not connect the full bridge black speaker connectors to ground as these outputs are driven.

1.4 CS8416 Digital Audio Receiver

The operation of the CS8416 receiver and a discussion of the digital audio interface are described in the CS8416 data sheet.

The CS8416 converts the input S/PDIF data stream into PCM data for the CS44600. The CS8416 operates in master mode with $RMCK = 256 \cdot F_s$. The digital Interface format is set to Left Justified (24-bit).

D20 (RERR) indicates a receiver error, such as loss of lock.

S/PDIF input is through OPT1 or J33.

1.5 CS5341 Analog to Digital Converter

The operation of the CS5341 ADC is described in the CS5341 data sheet.

The CS5341 converts analog audio into PCM data for the CS44600. The CS5341 operates in slave mode and the digital Interface format is set to Left Justified (24-bit).

Analog input is through J5 and J6.

1.6 Control Port Interface and GUI

The CS44600 and CS8416 are controlled through the provided control port interface. Connection to the control port is made through J37 (RS-232 Serial). A Windows based GUI provides control over all the individual registers of the CS44600 and the CS8416.

1.7 Unregulated Linear Power Supply

The power supply used for the CRD44600-PH-FB is a linear 155 W supply. The supply provides an unregulated +50 V for the TDA8939 power stages. The power supply consists of a transformer, diode bridge rectifier, and bulk capacitor. Schematics are shown in Figure 14.

2. GUI CONTROL

The CRD44600-PH-FB is shipped with a Microsoft Windows® based GUI, which allows control over the CS8416 and CS44600 registers. Interface to the CDB44600 control port is provided using an RS-232 serial cable. The GUI requires no installation and can be run directly from the CD or copied to a local directory and run from there. Once the serial port cable is connected between the CRD44600-PH-FB and the host PC, load the FlexLoader.exe from the CRD44600-PH-FB directory. Once loaded, all registers are set to their default reset state. The GUI File menu provides the ability to save and restore (load) register settings. Sample script files are provided for basic functionality. The GUI serial port interface is setup by default for 115.2 Kbps operation on COM1. To change these settings, edit the “CRD44600-PH-FBCommunications” section of the flexconfig.ini file or change the system communications setting in the Windows® control panel.

2.1 CS44600 Dialog Tab

The CS44600 Dialog tab provides high level control over the CS44600’s registers. Controls are provided to change volume, mute, enable PSR, enable the power stages, limiter control.

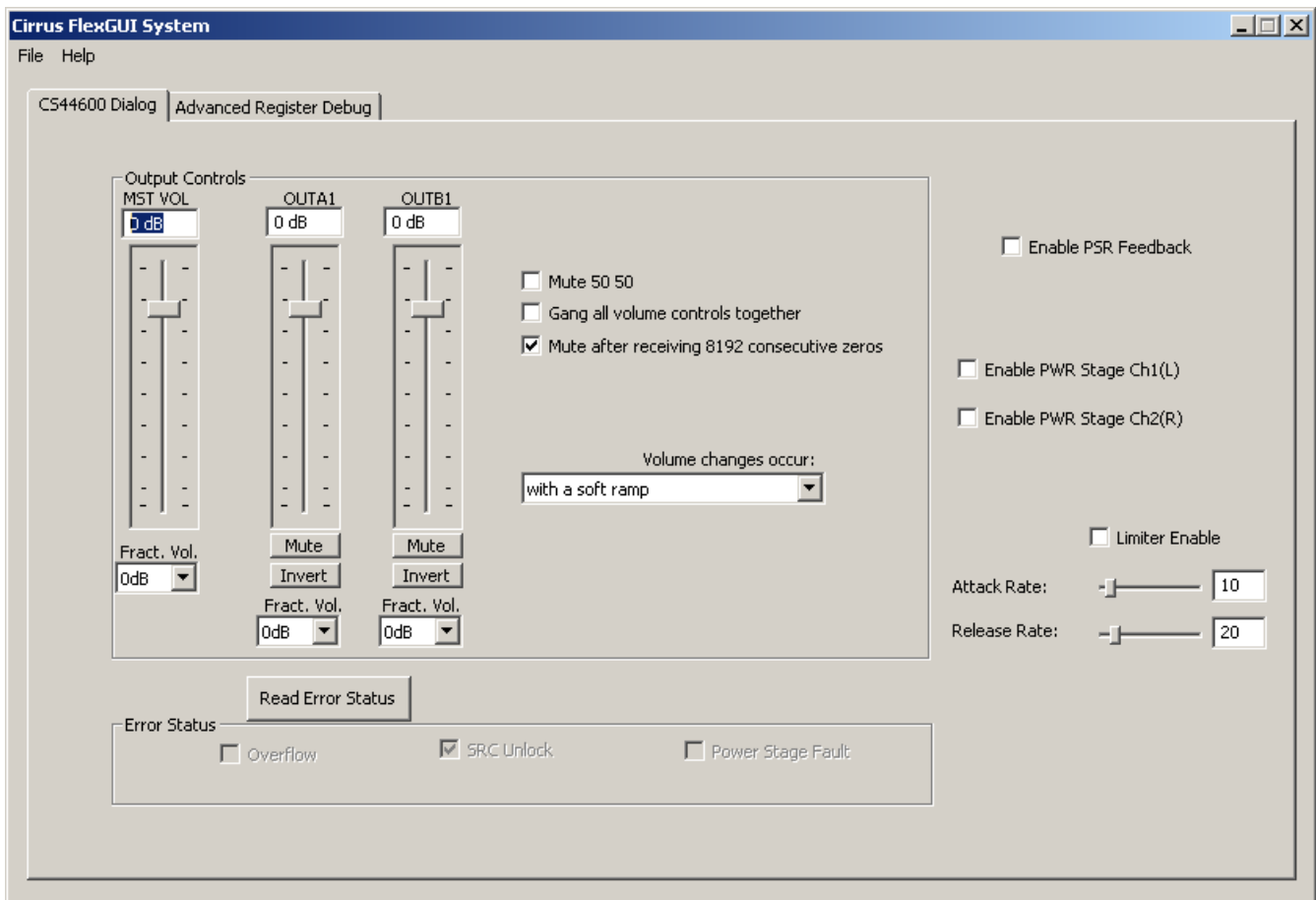

Figure 1. CS44600 Dialog Tab

2.2 Advanced Register Debug Tab

The Advanced Register Debug tab provides low level control over the CS44600 and CS8416 individual register settings. Each device is displayed on a separate tab. Register values can be modified bitwise or byte-wise. For bitwise, click the appropriate push button for the desired bit. For byte-wise, the desired hex value can be typed directly in the register address box in the register map.

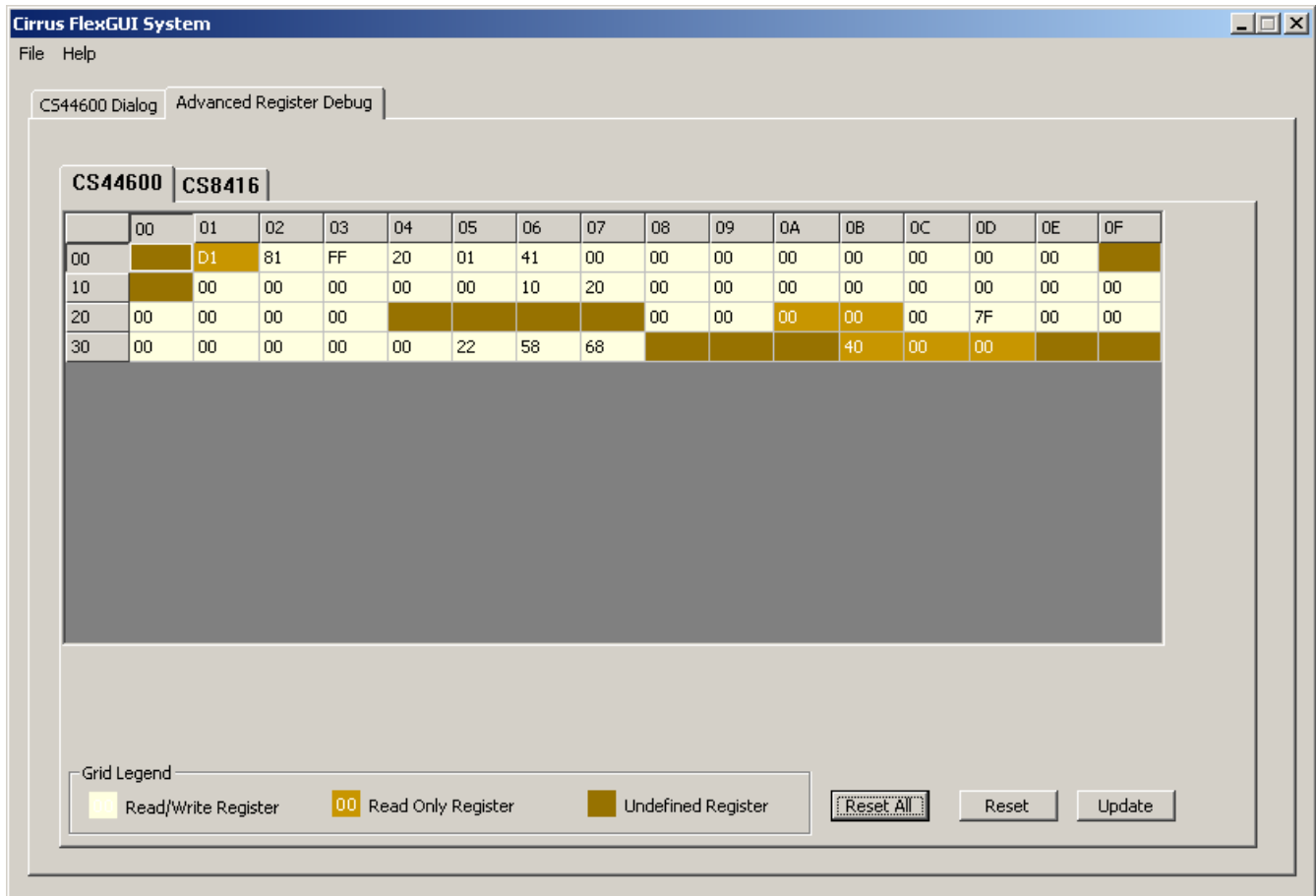

Figure 2. Advanced Register Debug Tab - CS44600

Cirrus FlexGUI System

File Help

CS44600 Dialog Advanced Register Debug

CS44600 CS8416

	00	01	02	03	04	05	06	07	08	09	0A	0B	0C	0D	0E	0F
00	00	00	00	00	01	00	00	00	00	00	00	01	00	00	00	00
10	00	00	00	00	00	00	00	00	00	00	00	00	00	00	00	00
20	00	00	00	00	00	00	00									
30																
40																
50																
60																
70																2F

Reg: 00 Control0

0 0 0 0 0 0 0 0

FSWCLK PDUR TRUNC

Grid Legend

- Read/Write Register
- 00 Read Only Register
- Undefined Register

Reset All Reset Update

Figure 3. Advanced Register Debug Tab - CS8416

3. POWER SUPPLY

3.1 Power Supply Ratings

The required power supply current rating can be estimated as follows. 95 W is used as the reference output power per channel because this represents the typical full scale output with no clipping. Assume the efficiency, η , is approximately 85% (this accounts for power to supply control electronics and overhead), then for 95 W x 2 channels:

$$P_{Total} = \frac{P_{Out}}{\eta} = \frac{190 W}{0.85} = 224 W$$

$$P_{Supply} = \frac{P_{Total}}{2} = \frac{224 W}{2} = 112 W$$

Consequently the supply current is:

$$I_{Supply} = \frac{P_{Supply}}{V_{Supply}} = \frac{112 W}{50 V} = 2.24 A$$

The factor of 2 in the denominator of the P_{Supply} calculation arises from the fact that for typical consumer applications in A/V or DVD receivers, the power supply should be capable of providing $\frac{1}{2}$ the total requirement for all channels operating at full power. This design guide is still quite conservative, and gives more than adequate headroom in real applications.

3.2 Power Supply Decoupling

Proper power supply decoupling is one key to maximizing the performance of a Class-D amplifier. Because the design uses an open loop output stage, noise on the power supply rail will be coupled to the output. While the PSR functionality of the CS44600 helps reduce power supply noise feedthrough to the output, careful decoupling of the power stage supply rails is essential. Referring to Figure 15, the top side of the CRD44600-PH-FB PWM amplifier board, good decoupling practice is shown. Notice that the 0.1 μ F ceramic capacitors are as close as physically possible to the power pins of the TDA8939. The ground side of the capacitors is connected directly to top side ground plane, which is also used by the power supply return pins. This keeps the high frequency current loop small to minimize power supply variations and EMI. 470 μ F electrolytic capacitors are also located in close proximity to the power supply pins to supply the current locally for each channel. These are not required to be expensive low ESR capacitors. General purpose electrolytic capacitors that are specified to handle the ripple current can be used. The real time PSR feedback of the CS44600/CS4461 can greatly attenuate the induced voltages due to the power supply ripple current.

4. ELECTROMAGNETIC INTERFERENCE (EMI)

This reference design from Cirrus Logic is a board level solution which is meant to control emissions by minimizing and suppressing them at the source in contrast to containing them in an enclosure. Utilizing spread spectrum modulation techniques to reduce the overall switching energy, along with a low internal modulator clock frequency of 24.576 MHz, the radiated emissions are greatly reduced. These features allow for the use of very low cost components to couple the high frequency noise to chassis ground. No common mode chokes, inductors, or power line filters were required.

The EMI requirements for an amplifier have added dimensions beyond those imposed on power supplies. Audio amplifiers are usually located in close proximity to radio receivers, particularly AM receivers which are notoriously sensitive to interference. Amplifiers also need to operate with speaker leads of unpredictable length and construction which make it possible for any high frequency currents that appear on the outputs to generate nuisance emissions.

4.1 Suppression of EMI at the Source

Several techniques are used in the circuit design and board layout to minimize high frequency fields in the immediate vicinity of the high power components. Specific techniques include the following:

- As was mentioned in Section 3.2, effective power supply decoupling of high frequency currents, and minimizing the loop area of the decoupling loop is one aspect of minimizing EMI.
- Each output of the TDA8939 includes “snubbing” components. For example, OUT1 of U1 includes snubber components R18/R30 (5.6 Ω) and C34/C46 (560 pF). These components serve to damp ringing on the switching outputs in the 30-50 MHz range. The snubbing components should be as close as practical to the output pins to maximize their effectiveness. Again, refer to Figure 15 for the preferred component layout.
- A separate ground plane with a capacitively coupled electrical connection to the chassis and which surrounds the speaker output connector should be implemented. This allows the speaker outputs to be AC coupled to the chassis just before they exit the chassis from the speaker connector. Again, refer to Figure 15 for the preferred component layout.
- Make use of source termination resistors on all digital signals whose traces are longer than approximately 25 mm.

It is extremely critical that the layout of the power amplifier section of the Cirrus Logic CS44600 Reference Design be copied as exactly as possible to assure best RF/EMI performance.

4.2 EMI Testing

The CRD44600-PH-FB has been tested to CISPR and FCC Class B limits for radiated and power line conducted emissions. The same test setup and test signal were used for all tests. The setup consisted of an unregulated linear power supply, CRD44600-PH-FB board, 5m of speaker cable, and two 8- Ω resistive loads. This setup is shown in Figure 4

and Figure 5. The power supply earth ground was connected to the board chassis ground at a single point.

A CD-player with an optical fiber connection was used a signal source. A constant 0-dBFS, 1-kHz sine wave was used as the test signal and the board volume was set so that the output to the resistive loads was 1/8th of the full scale output level, or 12.5 W.

The test results shown in Figure 6 and Figure 7 are pre-screened radiated EMI test results from an antenna placement of 3 m in an anechoic chamber. The test results shown in Figure 8 are preliminary power line conducted test results.

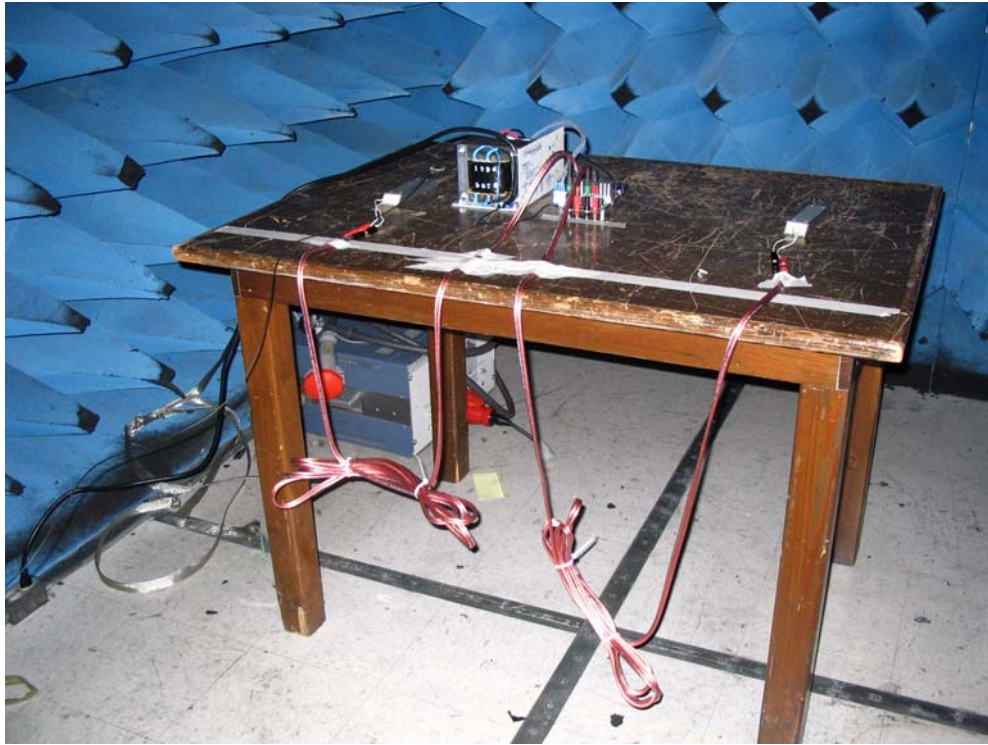

Figure 4. EMI Testing Setup

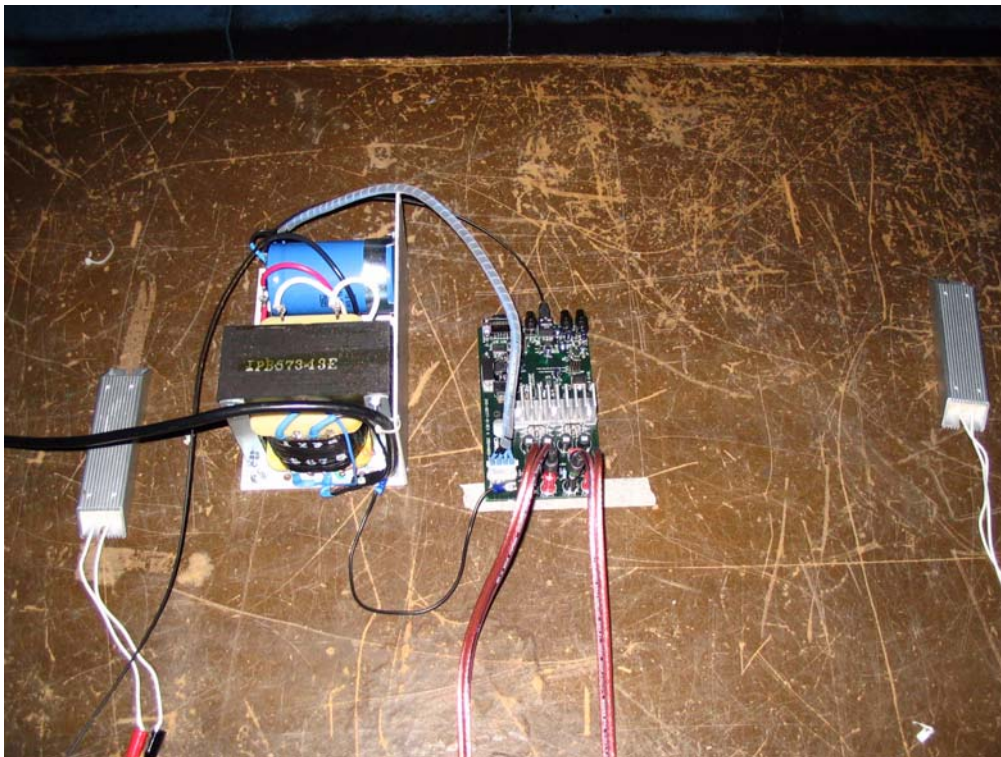

Figure 5. EMI Testing Setup, Close-up

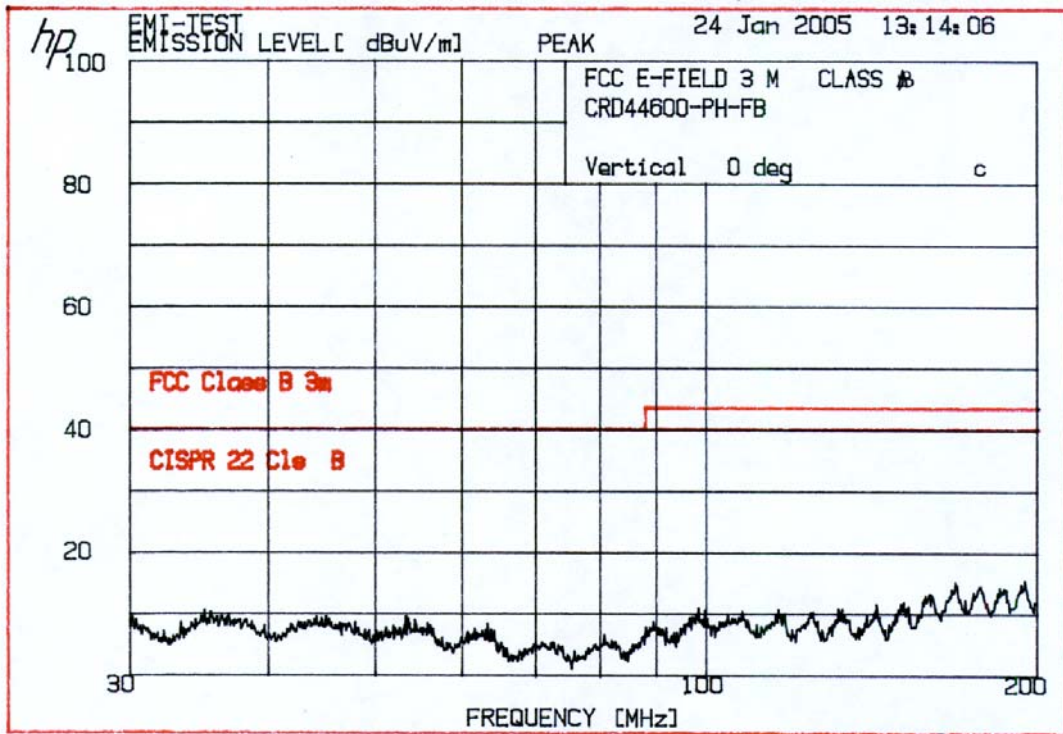

Figure 6. Radiated EMI Testing Results- 30 MHz to 200 MHz

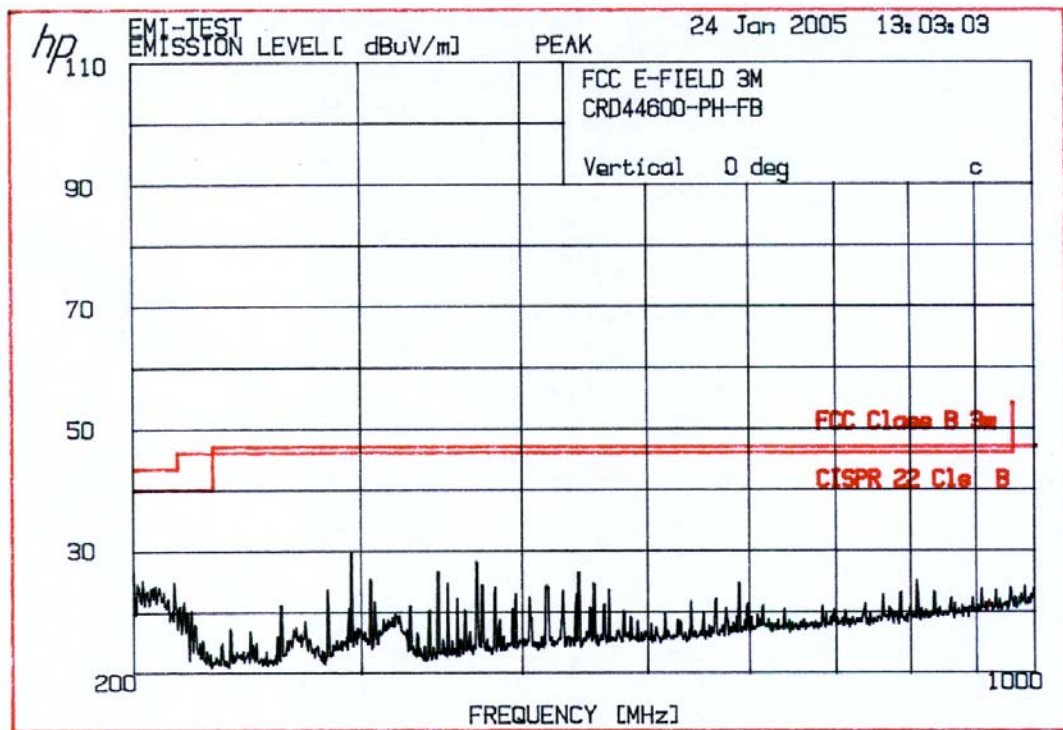

Figure 7. Radiated EMI Testing Results- 200 MHz to 1 GHz

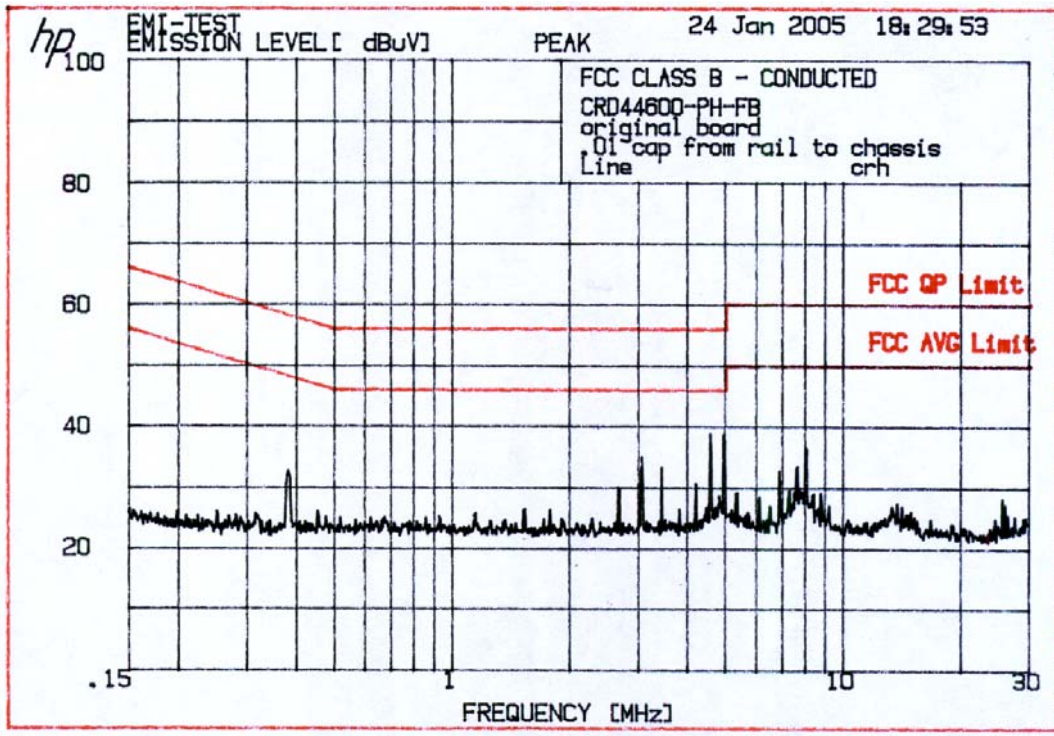

Figure 8. Conducted Power Line Testing Results

***Output Filter Optimized for 8 ohm Load.**

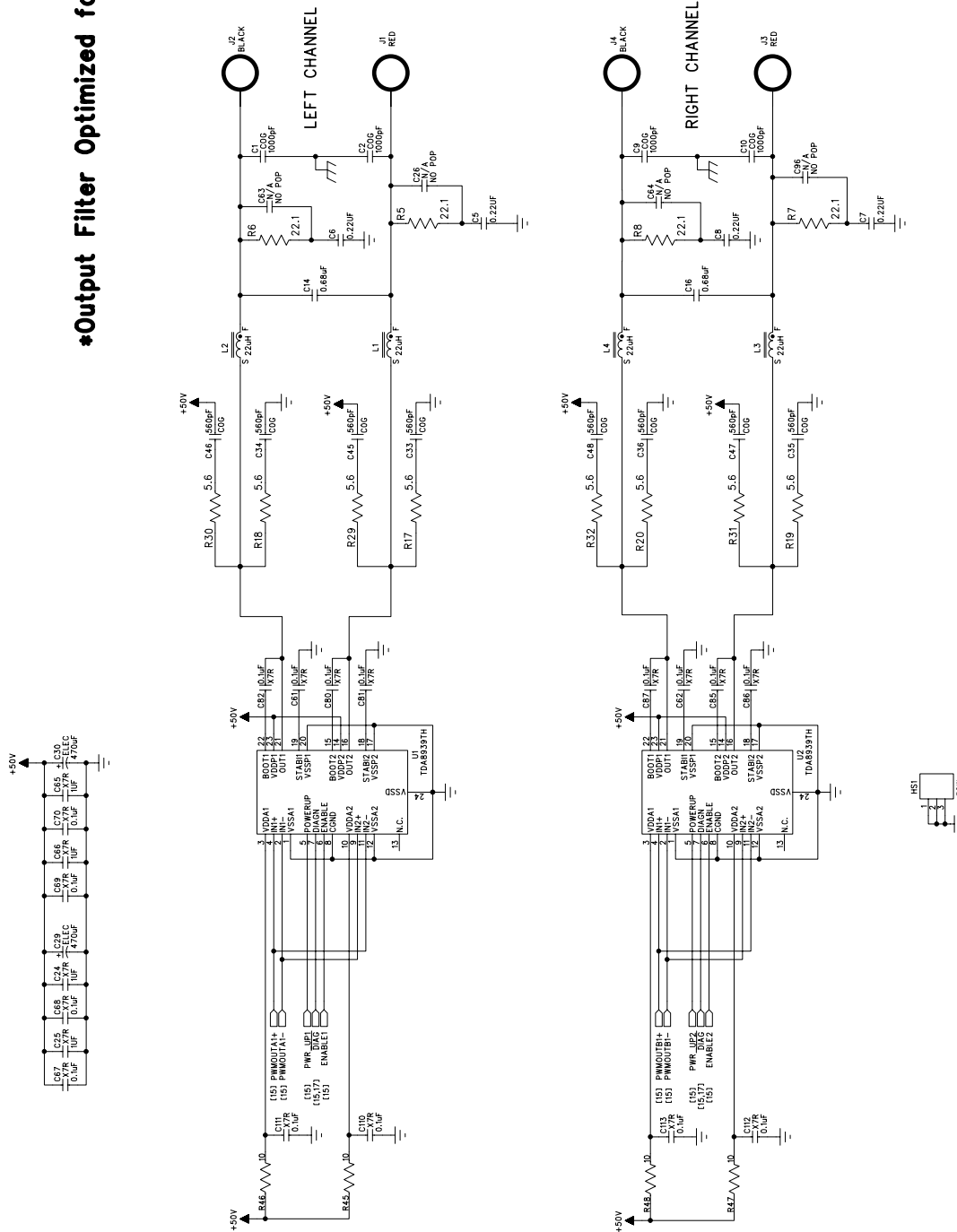
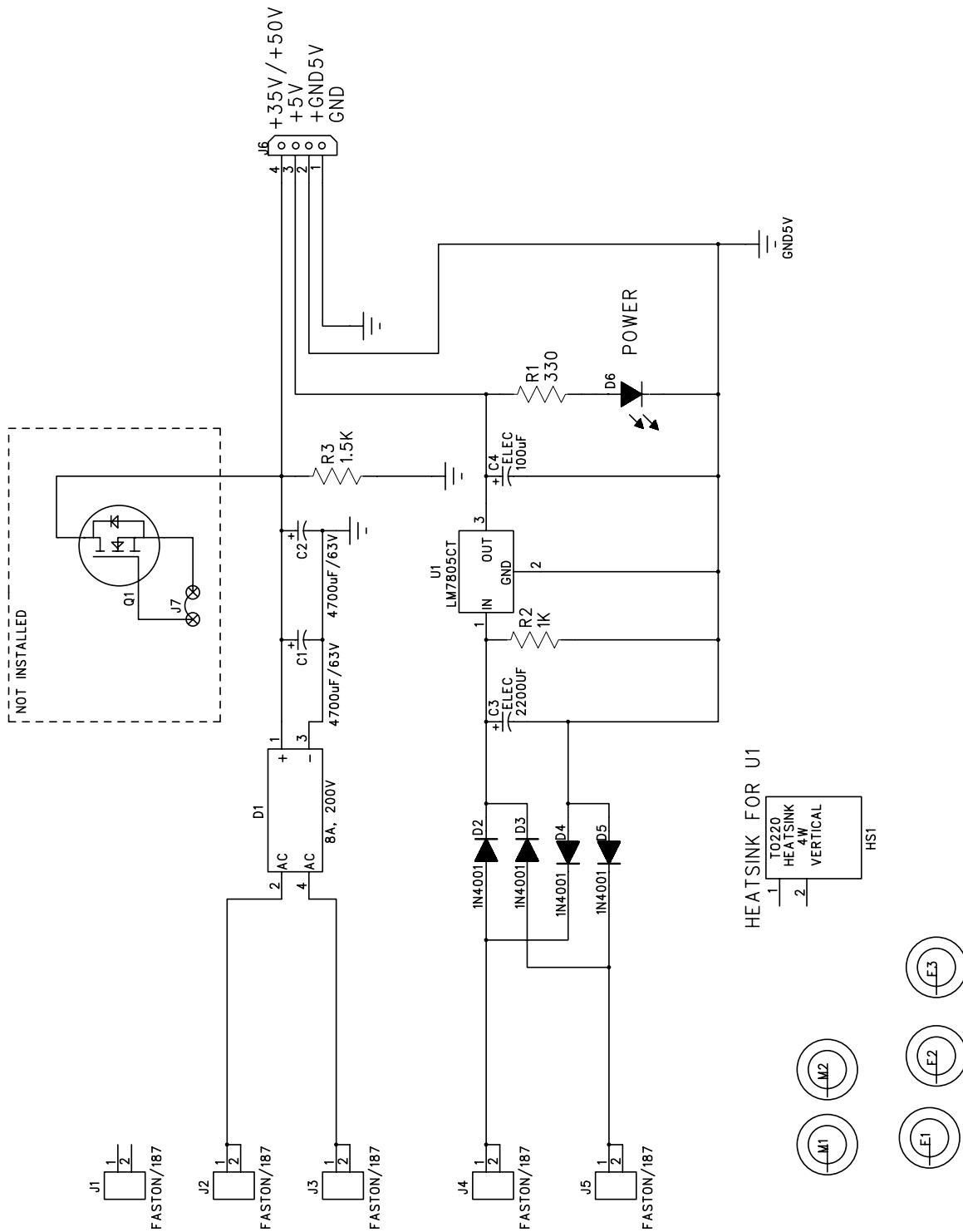
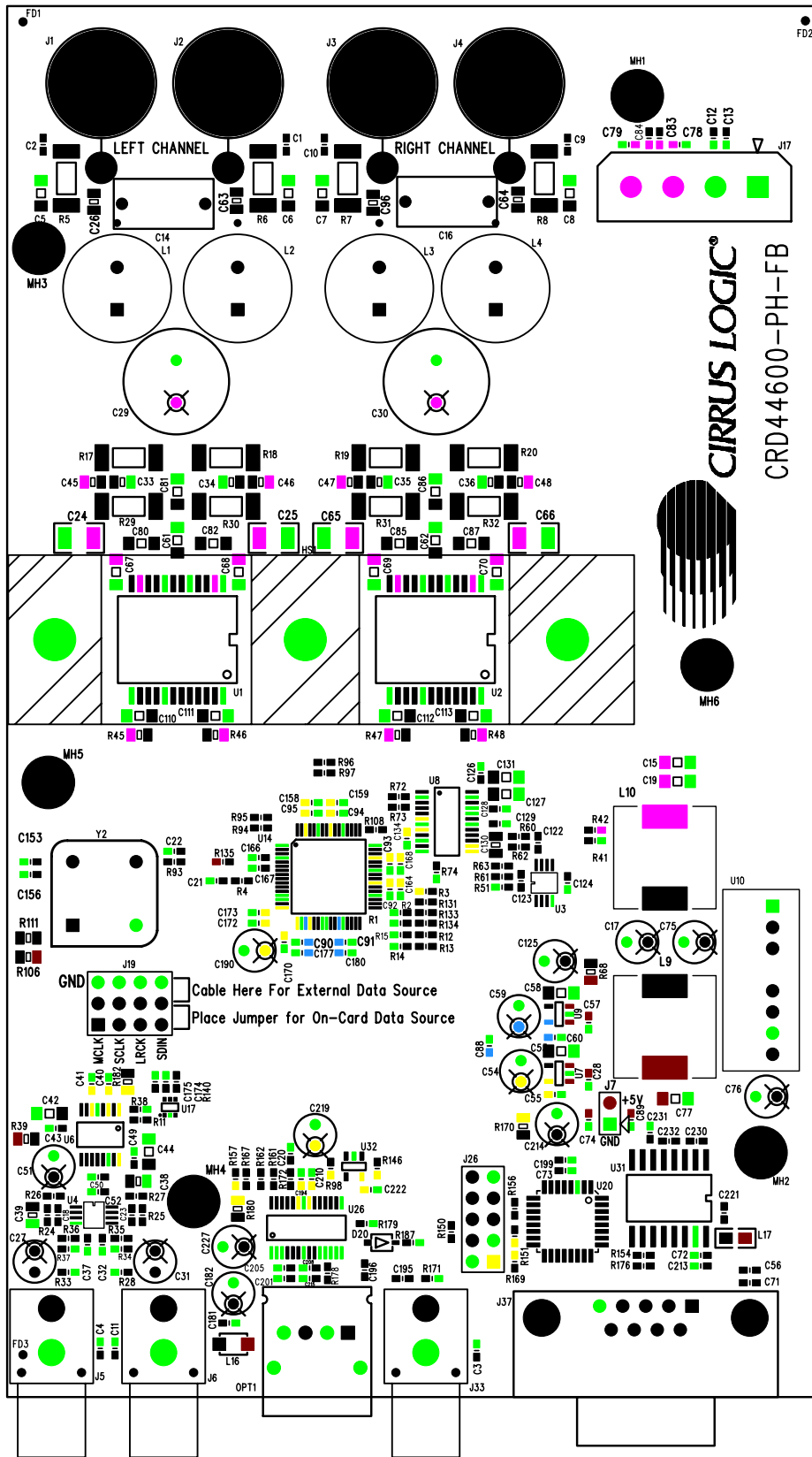

Figure 12. Left/Right Channels

6. CRD44600-PH-FB POWER SUPPLY SCHEMATICS

Figure 14. Power Supply

7. CRD44600-PH-FB LAYOUT

Figure 15. Silk Screen Top

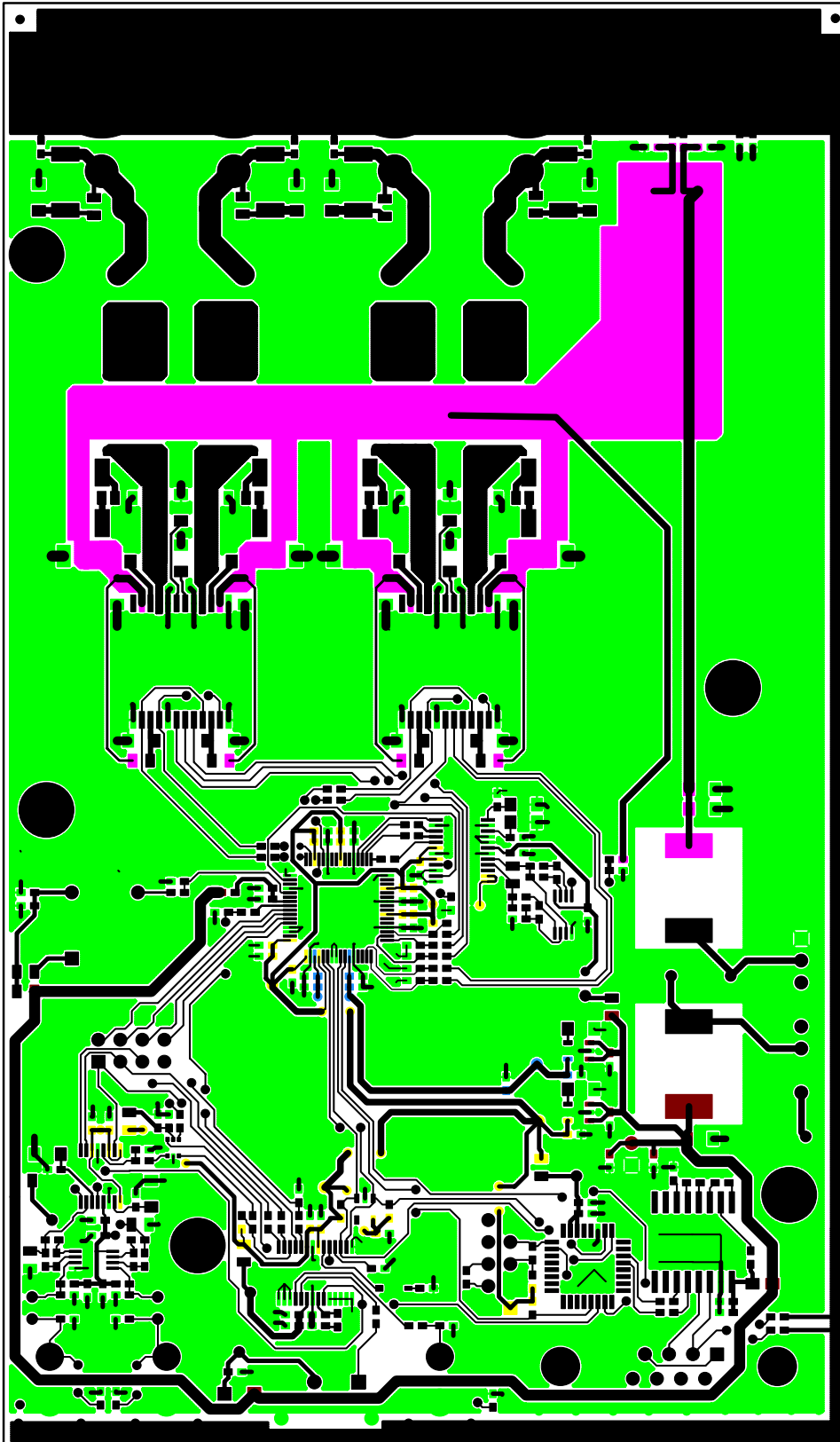

Figure 16. Topside Layer

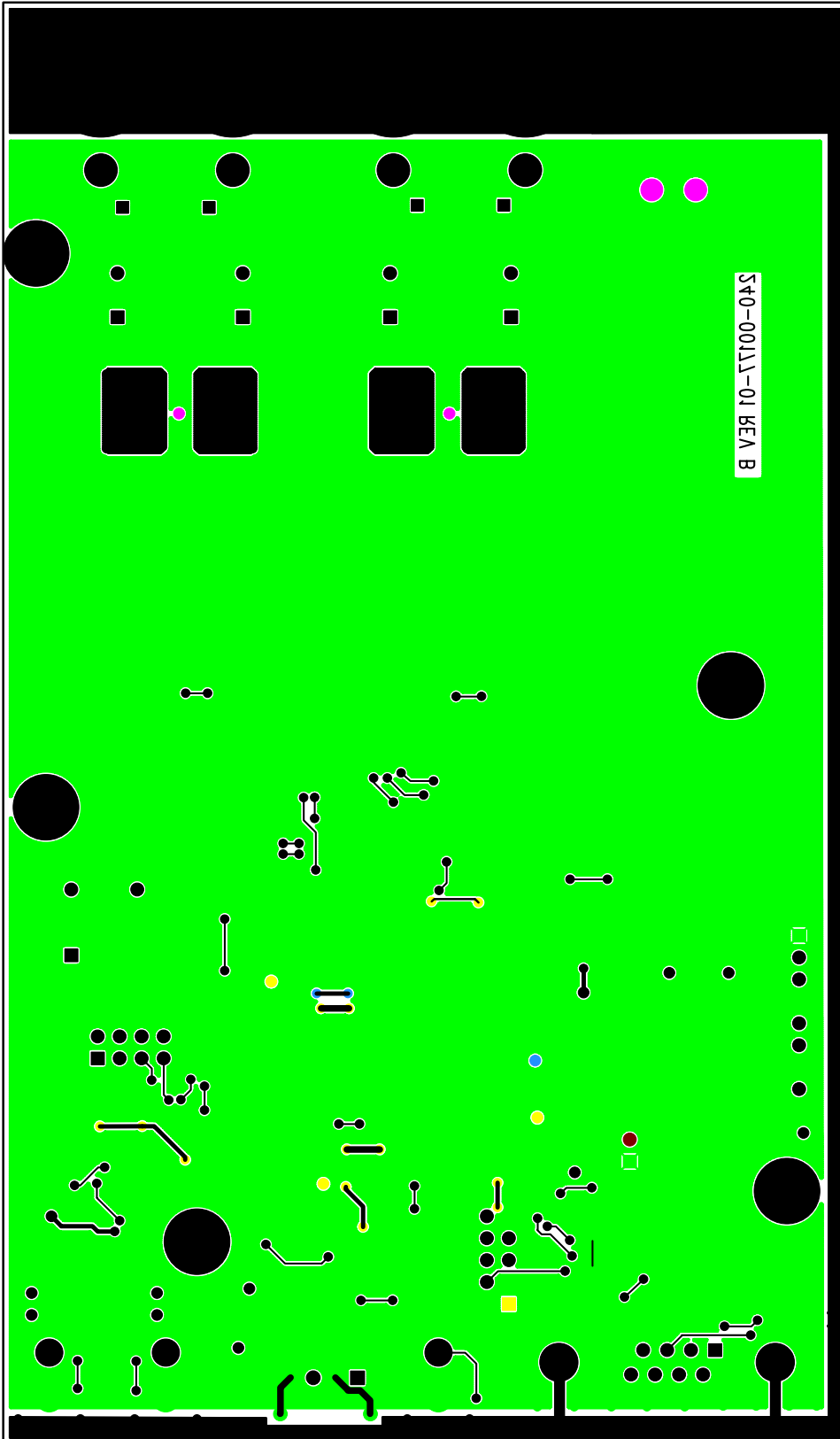

Figure 17. Bottomside Layer

Item	Description	Qty	Reference Designator	MFG	MFG P/N
1	CAP 1000pF ±5% 50V C0G 0603	21	C1 C2 C4 C9 C10 C11 C12 C56 C71 C72 C73 C83 C88 C89 C153 C167 C173 C174 C205 C208 C210	PANASONIC	ECJ1VC1H102J
2	NO POP CAP 0603	0	C3 C20 C21 C22 C78 C79	NO POP	NP-CAP-0603
3	CAP 0.22uF ±5% 50V X7R 1206	4	C5 C6 C7 C8	KEMET	C1206C224J5RAC
4	CAP 0.01uF ±10% 50V X7R 0603	10	C13 C84 C90 C91 C92 C93 C94 C95 C195 C196	KEMET	C0603C103K5RAC
5	CAP 0.68uF ±10% 100V POLY RAD	2	C14 C16	PANASONIC	ECQE1684KF
6	CAP 0.1uF ±10% 100V X7R 1206	18	C15 C19 C61 C62 C67 C68 C69 C70 C80 C81 C82 C85 C86 C87 C110 C111 C112 C113	KEMET	C1206C104K1RAC
7	CAP 100uF ±20% 10V ELEC RAD 5X11	6	C17 C51 C76 C125 C214 C227	PANASONIC	ECA1AM101
8	CAP 470pF ±5% 50V C0G 0603	2	C18 C23	KEMET	C0603C471J5GAC
9	CAP 1uF ±10% 100V X7R 1210	4	C24 C25 C65 C66	MURATA	GRM32ER72A105KA01 L
10	NO POP CAP 0805	0	C26 C63 C64 C96	NO POP	NP-CAP-0805
11	CAP 10uF ±20% 50V ELEC RAD	7	C27 C31 C54 C59 C182 C190 C219	PANASONIC	ECA1HM100I
12	CAP 0.1uF ±10% 16V X7R 0603	39	C28 C32 C37 C40 C41 C43 C49 C50 C52 C55 C57 C60 C74 C124 C126 C128 C129 C134 C156 C158 C159 C164 C166 C168 C170 C172 C175 C177 C180 C181 C194 C199 C201 C213 C221 C222 C230 C231 C232	KEMET	C0603C104K4RAC
13	CAP 470uF ±20% 63V ELEC RAD	2	C29 C30	PANASONIC	ECA1JM471B
14	CAP 560pF ±5% 100V C0G 0805	8	C33 C34 C35 C36 C45 C46 C47 C48	KEMET	C0805C561J1GAC
15	CAP 2200pF ±5% 50V C0G 0805	3	C38 C39 C130	KEMET	C0805C222J5GAC
16	CAP 1uF ±10% 25V X7R 1206	5	C42 C44 C77 C127 C131	KEMET	C1206C105K3RAC
17	CAP 0.01uF ±5% 25V C0G 1206	2	C53 C58	KEMET	C1206C103J3GAC
18	CAP 10uF ±20% 63V ELEC RAD 5x11	1	C75	PANASONIC	ECA1JM100I
19	CAP 120pF ±5% 50V C0G 0603	2	C122 C123	KEMET	C0603C121J5GAC
20	CAP 0.022uF ±5% 50V X7R 0603	1	C215	KEMET	C0603C223J5RAC
21	LED CLR SUP RED 1.7V 1mA 1.6MCD SMD	1	D20	CHICAGO MINIATURE	CMD28-21SRC/TR8/T1
22	HTSNK 30W DUAL SITE	1	HS1	SUMMIT HEAT SINKS CO LTD	311-00005-01
23	CON BPOST 2" SILV NYLON INS RED	2	J1 J3	JOHNSON COMPONENTS	111-0102-001
24	CON BPOST 2" SILV NYLON INS BLK	2	J2 J4	JOHNSON COMPONENTS	111-0103-001
25	JACK RCA, RA-BLK, PHONO, GLD TABS	3	J5 J6 J33	A/D ELECTRONICS	ARJ-2018-NIL-1-NIL
26	HDR 2x1 ML .1"CTR 062BD ST GLD TH	1	J7	SAMTEC	TSW-102-07-G-S
27	CON PWR SHIELDED 4PIN	1	J17	MOLEX	15-24-4049
28	HDR 4x3 MLE .1"CTR S GLD	1	J19	SAMTEC	TSW-104-07-G-T
29	HDR 5x2 MLE .1"CTR S GLD	1	J26	SAMTEC	TSW-105-07-G-D
30	CON DSUB 9P FML .318"W W/ BDLCCK RA	1	J37	AMP	747844-6
31	IND 22uH 6A ±10% 400 DIA TH	4	L1 L2 L3 L4	TRANSTEK MAGNETICS	TMP50627CT
32	IND 47uH 20% CDRH125 SERIES SMT	1	L9	SUMIDA	CDRH125-470MC
33	IND 680uH 20% CDRH125 SERIES SMT	1	L10	SUMIDA	CDRH125-681MC
34	IND 47uH ±10% 1210	1	L16	PANASONIC	ELJFA470KF
35	IND 4.7uH ±10% 0805	1	L17	PANASONIC	ELJFD4R7KF
36	SPCR, STANDOFF 4-40 THR, 0.875"L	6	MH1 MH2 MH3 MH4 MH5 MH6	KEYSTONE	1809
37	OPTICAL RCVR 6Mb/s 7V 20MA 10M	1	OPT1	TOSHIBA	TORX173
38	RES 10k OHM 1/10W ±1% 0603 FILM	10	R1 R2 R3 R14 R15 R38 R74 R157 R169 R179	DALE	CRCW06031002F

Table 1. Bill of Materials

8. CRD44600-PH-FB BILL OF MATERIALS



CIRRUS LOGIC®

CRD44600-PH-FB

Item	Description	Qty	Reference Designator	MFG	MFG P/N
39	RES 22.1 OHM 1/10W ±1% 0603 FILM	12	R4 R11 R72 R73 R93 R108 R154 R161 R162 R167 R172 R176	DALE	CRCW060322R1F
40	RES 22.1 OHM 1W ±1% 2512 FILM	4	R5 R6 R7 R8	DALE	CRCW251222R1F
41	RES 90.9 OHM 1/10W ±1% 0603 FILM	15	R12 R13 R26 R27 R62 R63 R94 R95 R96 R97 R131 R133 R134 R135 R140	DALE	CRCW060390R9F
42	RES 5.6 OHM 1W ±5% 2512 FILM	8	R17 R18 R19 R20 R29 R30 R31 R32	DALE	CRCW25125R6J
43	RES 649 OHM 1/10W ±1% 0603 FILM	4	R24 R25 R60 R187	DALE	CRCW06036490F
44	RES 100k OHM 1/10W ±1% 0603 FILM	6	R28 R33 R34 R35 R36 R37	DALE	CRCW06031003F
45	RES 10 OHM 1/8W ±5% 0805 FILM	10	R39 R45 R46 R47 R48 R68 R106 R170 R180 R182	DALE	CRCW0805100J
46	RES 2k OHM 1/10W ±1% 0603 FILM	5	R41 R51 R61 R98 R146	DALE	CRCW06032001F
47	RES 54.9k OHM 1/10W ±1% 0603 FILM	1	R42	DALE	CRCW06035492F
48	NO POP RES 0805	0	R111	NO POP	NP-RES-0805
49	RES 1k OHM 1/10W ±5% 0603 FILM	3	R150 R151 R156	DALE	CRCW0603102J
50	RES 75 OHM 1/10W ±1% 0603 FILM	1	R171	DALE	CRCW060375R0F
51	RES 3.01k OHM 1/10W ±1% 0603 FILM	1	R178	DALE	CRCW06033011F
52	IC LOG CLASS D PWR COMP HSOP24	2	U1 U2	PHILIPS	TDA8939TH
53	IC LNR DUAL OP AMP LOW V RRO VSP8	2	U3 U4	NJR	NJM2140R
54	IC CRUS, 105dB 192kHz M-BIT AUD ADC	1	U6	CIRRUS LOGIC	CS5341-CZZ/E
55	IC LNR VREG μPWR 150mA 3.3V SOT23-5	1	U7	NATIONAL SEMICONDUCTOR	LP2985IM5-3.3
56	IC CRUS A/D PSR FEEDBACK TSSOP24	1	U8	CIRRUS LOGIC	CS4461-CZZ/D
57	IC LNR VREG μPWR 150MA 2.5V SOT23-5	1	U9	NATIONAL SEMICONDUCTOR	LP2985IM5-2.5
58	IC LNR ISO 2W SINGLE OUT DC-DC CONV	1	U10	C&D TECHNOLOGIES	NDL4805S
59	IC CRUS 6-CH DIG AMP CTRL LQFP64	1	U14	CIRRUS LOGIC	CS44600-CQZ/A
60	IC LOG, UHS 2IN NON INV MUX SC70-6	1	U17	FAIRCHILD SEMICONDUCTOR	NC7SZ157P6X
61	IC PGM USB 16kB FLASH MCU LQFP32	1	U20	CYGNAL	C8051F320
62	IC CRUS 192kHz DIG AUD RCVR TSSOP28	1	U26	CRYSTAL SEMICONDUCTOR	CS8416-CZ/E
63	IC LNR 5V RS-232 DRV/RCVR SO16-300	1	U31	MAXIM	MAX232ACWE
64	IC PGM 128 BIT SER EEPROM SOT23-5	1	U32	MICROCHIP	24LC00-I/OT
65	OSC 24.576MHz 50PPM 5V HALF DIP8	1	Y2	CAL CRYSTAL	CX21AH-24.576MHZ
66	WIRE, HOOK-UP 12AWG 65/30 RED 100ft	4	XJ1 XJ2 XJ3 XJ4	ALPHA WIRE COMPANY	3080 RD005
66	SCREW 4-40X5/16" PH STEEL	6	XMH1 XMH2 XMH3 XMH4 XMH5 XMH6	BUILDING FASTENERS	PMS 440 0031 PH
67	SCREW 4-40X1/4" L PH STEEL	3	XHS1	McMASTER-CARR	90190A106
68	WASHER LOCK INTERNAL #4	3	XHS1	BUILDING FASTENERS	INT LWZ 004

