



Chipsmall Limited consists of a professional team with an average of over 10 year of expertise in the distribution of electronic components. Based in Hongkong, we have already established firm and mutual-benefit business relationships with customers from,Europe,America and south Asia,supplying obsolete and hard-to-find components to meet their specific needs.

With the principle of "Quality Parts,Customers Priority,Honest Operation,and Considerate Service",our business mainly focus on the distribution of electronic components. Line cards we deal with include Microchip,ALPS,ROHM,Xilinx,Pulse,ON,Everlight and Freescale. Main products comprise IC,Modules,Potentiometer,IC Socket,Relay,Connector.Our parts cover such applications as commercial,industrial, and automotives areas.

We are looking forward to setting up business relationship with you and hope to provide you with the best service and solution. Let us make a better world for our industry!



Contact us

Tel: +86-755-8981 8866 Fax: +86-755-8427 6832

Email & Skype: info@chipsmall.com Web: www.chipsmall.com

Address: A1208, Overseas Decoration Building, #122 Zhenhua RD., Futian, Shenzhen, China



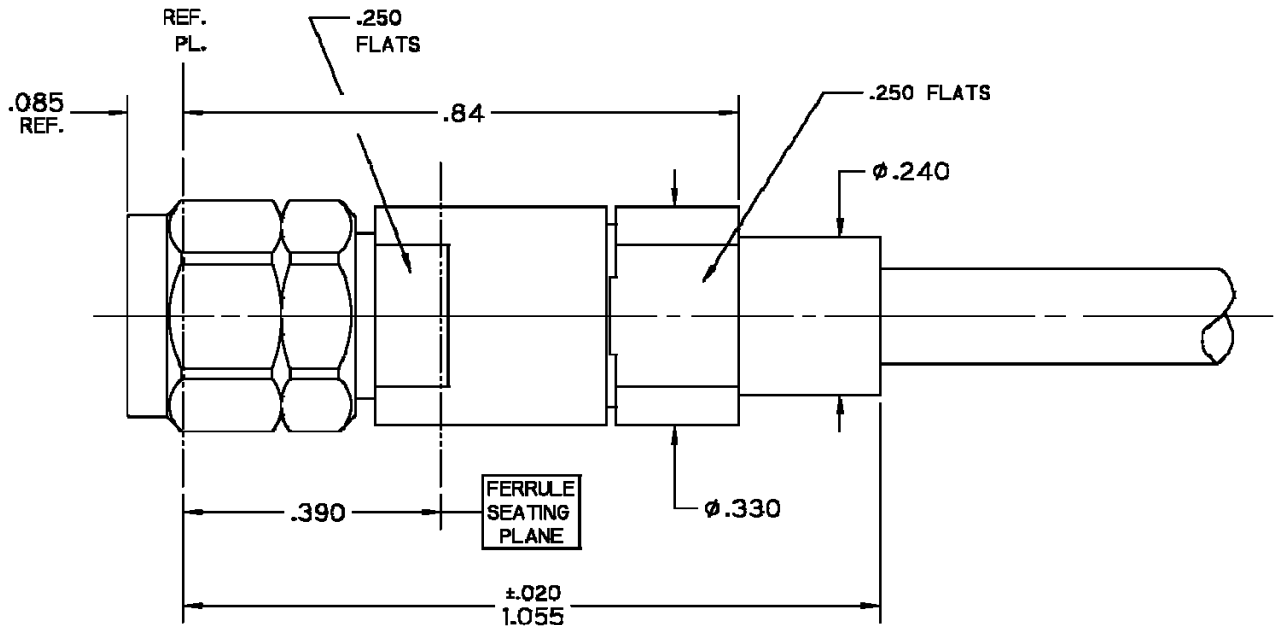

NOTES:

1.0 Materials

- 1.1 Body, Coupling, and Clamp Nuts: Steel. Corrosion Resistant per ASTM-A582. UNS No. S30300.
- 1.2 Center Conductor: Beryllium Copper per ASTM-B196. UNS C17300.
- 1.3 Solder Ferrule: Brass per ASTM-B16. UNS C36000.
- 1.4 Lock Ring: Beryllium Copper per ASTM-B197. UNS C17200.
- 1.5 Gasket and O-Ring: Silicone Rubber per A-A-59588.
- 1.6 Dielectric Bead: Polyphenylene Oxide (NORYL) per ASTM-D4349.
- 1.7 Cable Stop: Polyetherimide Thermoplastic (ULTEM 1000) per ASTM-D5205.

2.0 Finishes

- 2.1 Center Contact and Solder Ferrule: Gold Plate per ASTM-B488 50 Microinches Min. thickness over Electrolytic Nickel Plate per ASTM-B689 50 Microinches Min. thickness.
- 2.2 Body, Coupling, and Clamp Nuts: Passivated per SAE-AMS-2700.
- 2.3 Gasket, O-Ring, Lock Ring, and Dielectrics: None.

3.0 Interface: per CC-2.4mm-Pin.



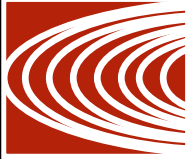

2.4mm Plug, Solder Clamp for IW1501 Cable

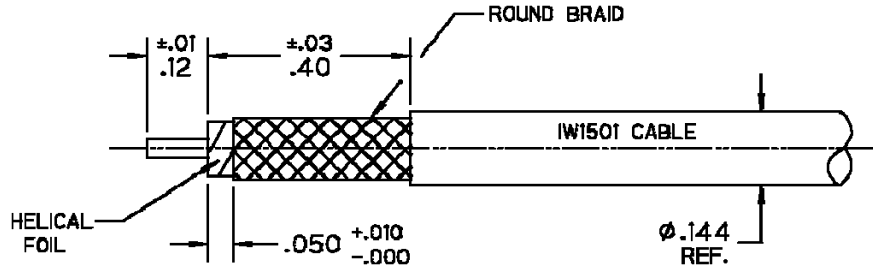

Step 1 1.1 Trim Cable as shown.

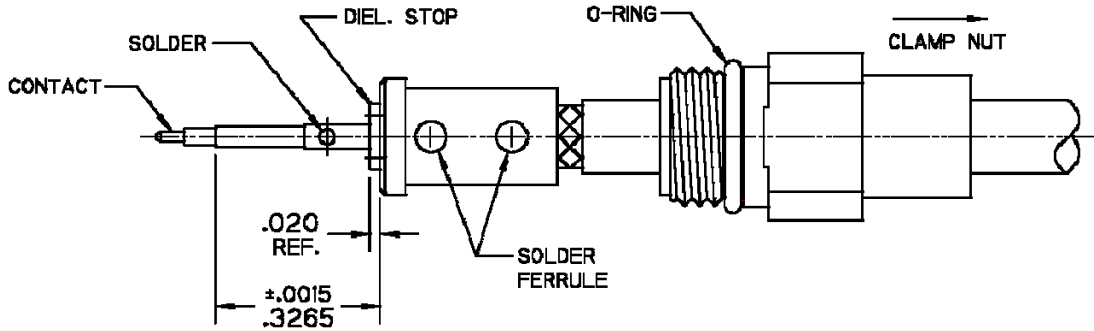

- 2.1 Install O-ring onto clamp nut where shown and slide clamp nut over cable in orientation shown.
- 2.2 Insert cable into solder ferrule until dielectric and foil are flush with solder ferrule face and solder cable braids where shown.
- 2.3 Slide dielectric stop over cable center conductor and solder contact flush to stop to dimension shown.

Step 2

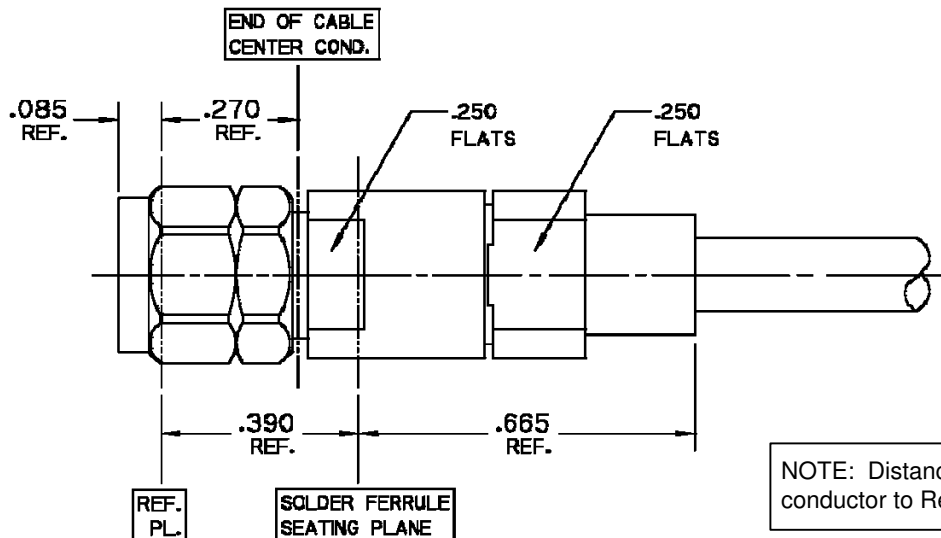

NOTE: Distance from end of cable center conductor to Ref. Pl. is 0.270 (Ref)

- 3.1 Insert cable/contact sub-assembly into connector until seated and tighten clamp nut to 25-35 in-lbs.

Step 3

Product Control:

Crystek Part Number:	CS-DM-MJB	Release Date:	04-Jan-11
Revision Level:	A	Responsible:	K. Piotrowicz

