



Chipsmall Limited consists of a professional team with an average of over 10 year of expertise in the distribution of electronic components. Based in Hongkong, we have already established firm and mutual-benefit business relationships with customers from,Europe,America and south Asia,supplying obsolete and hard-to-find components to meet their specific needs.

With the principle of "Quality Parts,Customers Priority,Honest Operation,and Considerate Service",our business mainly focus on the distribution of electronic components. Line cards we deal with include Microchip,ALPS,ROHM,Xilinx,Pulse,ON,Everlight and Freescale. Main products comprise IC,Modules,Potentiometer,IC Socket,Relay,Connector.Our parts cover such applications as commercial,industrial, and automotives areas.

We are looking forward to setting up business relationship with you and hope to provide you with the best service and solution. Let us make a better world for our industry!



Contact us

Tel: +86-755-8981 8866 Fax: +86-755-8427 6832

Email & Skype: info@chipsmall.com Web: www.chipsmall.com

Address: A1208, Overseas Decoration Building, #122 Zhenhua RD., Futian, Shenzhen, China



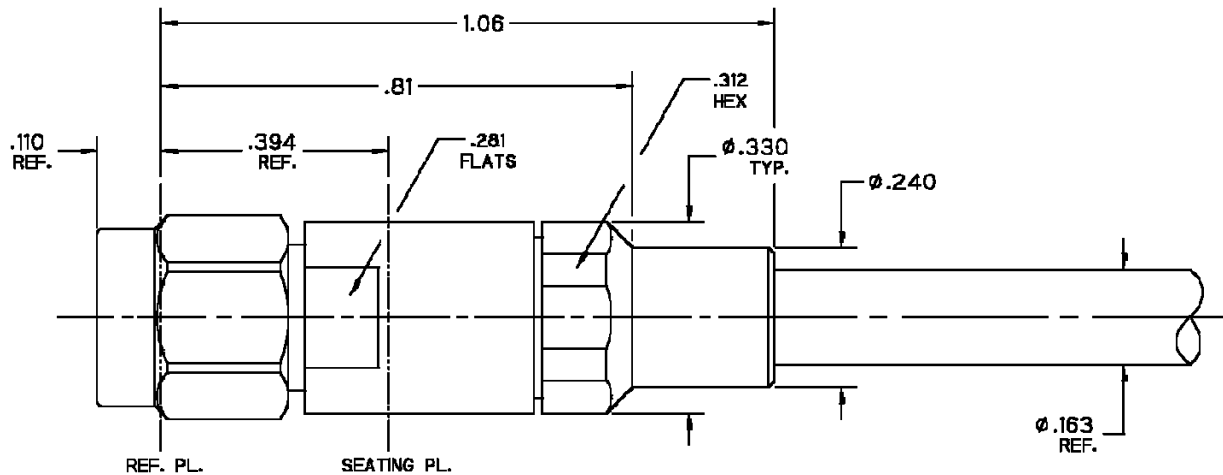

NOTE: Distance from end of cable center conductor to Ref. Pl. is 0.289

NOTES:

1.0 Materials

- 1.1 Body, Coupling, and Clamp Nuts: Steel. Corrosion Resistant per ASTM-A582. UNS No. S30300.
- 1.2 Center Conductor: Beryllium Copper per ASTM-B196. UNS C17300.
- 1.3 Solder Ferrule: Brass per ASTM-B16. UNS C36000.
- 1.4 Lock Ring: Beryllium Copper per ASTM-B197. UNS C17200.
- 1.5 Gasket and O-Ring: Silicone Rubber per A-A-59588.
- 1.6 Insulators: PTFE Fluorocarbon per ASTM-D1710.

2.0 Finishes

- 2.1 Center Contact and Solder Ferrule: Gold Plate per ASTM-B488 50 Microinches Min. thickness over Electrolytic Nickel Plate per ASTM-B689 50 Microinches Min. thickness.
- 2.2 Body, Coupling, and Clamp Nuts: Passivated per SAE-AMS-2700.
- 2.3 Gasket, O-Ring, and Dielectric Bead: None.

3.0 Interface: Type SMA Plug per Crystek Interface Specification CC-SMAP (Meets MIL-STD-348. Figure 310-1).

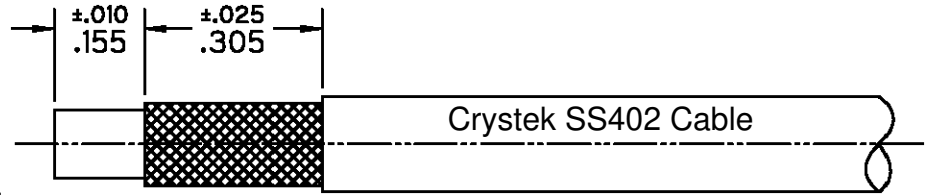

Step 1 1.1 Trim Cable as shown.

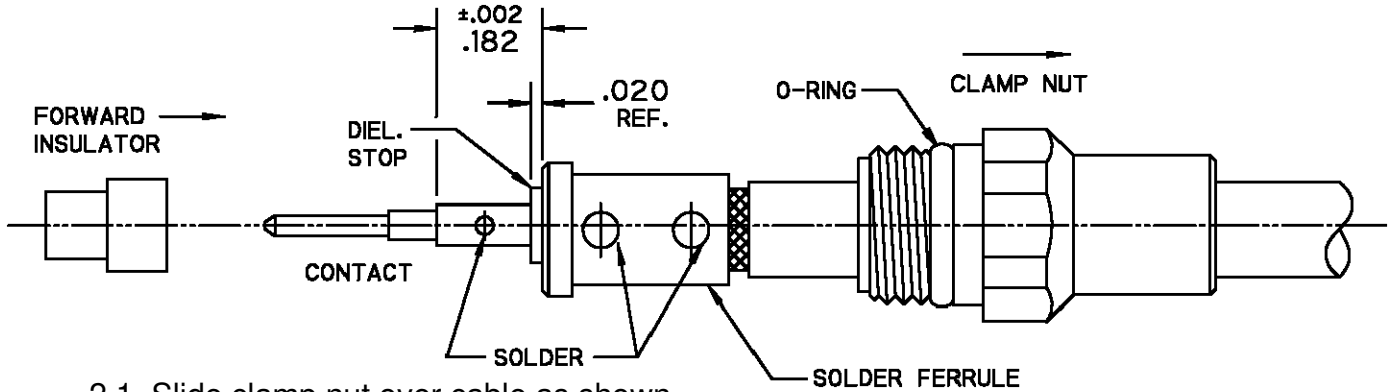

- 2.1 Slide clamp nut over cable as shown.
- 2.2 Insert cable into solder ferrule as shown then solder braids to ferrule where indicated.
- 2.3 Trim exposed cable dielectric flush with solder ferrule face.
- 2.4 Slide dielectric stop over cable center conductor against ferrule face and solder contact flush against stop to dimension shown.
- 2.5 Slide forward insulator onto contact.

Step 2

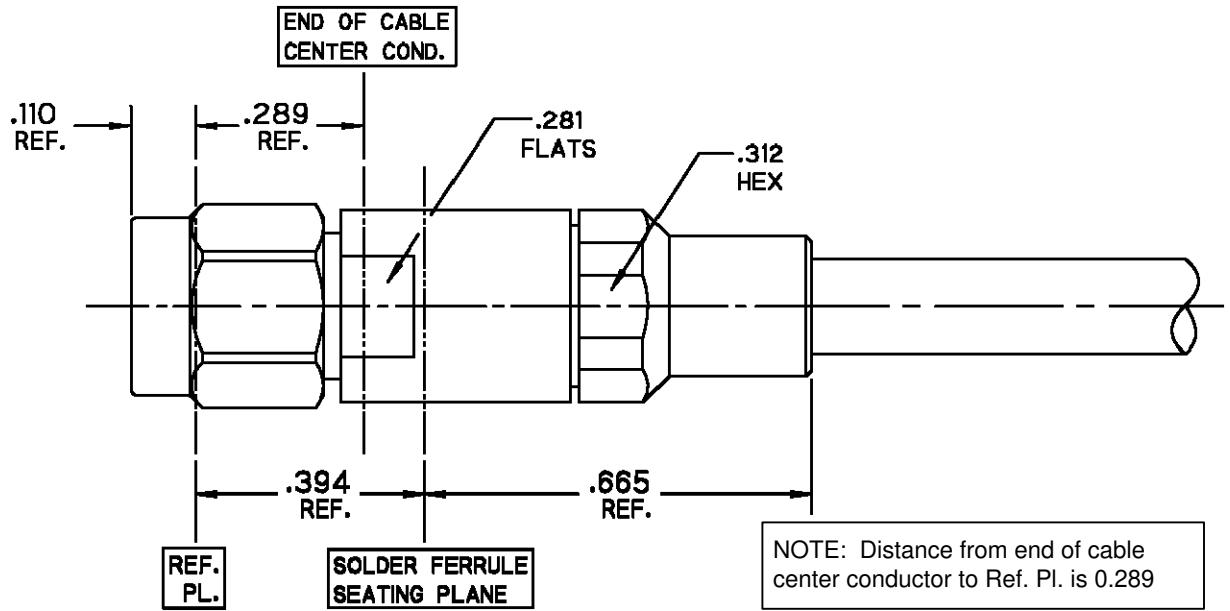

- 3.1 Insert cable/contact sub-assembly into connector until seated and tighten clamp nut to 25-35 in-lbs.

Step 3

Product Control:

Crystek Part Number:	CS-SM-MCA	Release Date:	03-Feb-11
Revision Level:	A	Responsible:	K. Piotrowicz

