



Chipsmall Limited consists of a professional team with an average of over 10 year of expertise in the distribution of electronic components. Based in Hongkong, we have already established firm and mutual-benefit business relationships with customers from,Europe,America and south Asia,supplying obsolete and hard-to-find components to meet their specific needs.

With the principle of “Quality Parts,Customers Priority,Honest Operation,and Considerate Service”,our business mainly focus on the distribution of electronic components. Line cards we deal with include Microchip,ALPS,ROHM,Xilinx,Pulse,ON,Everlight and Freescale. Main products comprise IC,Modules,Potentiometer,IC Socket,Relay,Connector.Our parts cover such applications as commercial,industrial, and automotives areas.

We are looking forward to setting up business relationship with you and hope to provide you with the best service and solution. Let us make a better world for our industry!



Contact us

Tel: +86-755-8981 8866 Fax: +86-755-8427 6832

Email & Skype: info@chipsmall.com Web: www.chipsmall.com

Address: A1208, Overseas Decoration Building, #122 Zhenhua RD., Futian, Shenzhen, China



CS1108

Single Lamp Driver IC

This ASIC provides up to 350 mA of drive current for powering bulbs. The typical application for this part is for use in airbag systems using a type 194 bulb. On-chip diagnostics provide open circuit and short circuit detection in the output on mode. In addition, the output driver will turn on (sink current) when V_{CC} is low. Fault is an active-low output which reports in the output-on mode. Internal pull-up circuitry is provided to ensure the output pin turns on when the Control pin is floating.

Features

- Fault Detection
 - Open Circuit
 - Short Circuit
 - Overtemperature
- V_{CC} Sense: Output Turns On with Loss of V_{CC}
- Low Standby Current
- Internally Fused Leads in SO-8 Package

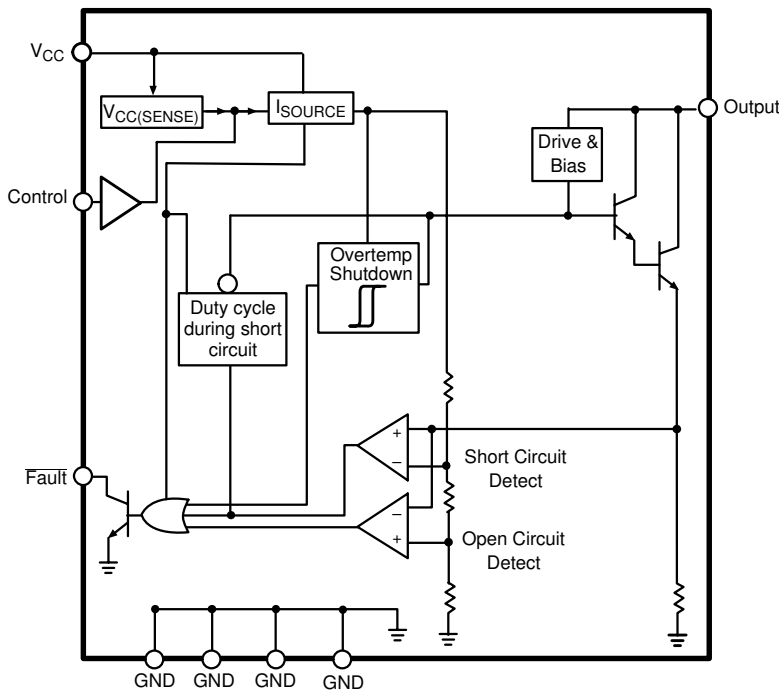

Figure 1. Block Diagram



ON Semiconductor™

<http://onsemi.com>



SO-8
DF SUFFIX
CASE 751

PIN CONNECTIONS AND MARKING DIAGRAM

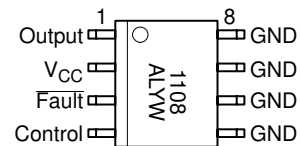

A = Assembly Location
WL, L = Wafer Lot
YY, Y = Year
WW, W = Work Week

ORDERING INFORMATION

Device	Package	Shipping
CS1108EDF8	SO-8	95 Units/Rail
CS1108EDFR8	SO-8	2500 Tape & Reel

MAXIMUM RATINGS*

Rating	Value	Unit
Storage Temperature	-65 to +150	°C
V _{CC} , Fault, Control	-0.5 to 6.0	V
ESD Capability (Human Body Model)	2.0	kV
Peak Transient Voltage (output off mode, output pin only)	(26 V Load Dump @ 14 V V _{BAT})	40
Lead Temperature Soldering:	Reflow: (SMD styles only) (Note 1)	230 peak

1. 60 second maximum above 183°C.

*The maximum package power dissipation must be observed.

ELECTRICAL CHARACTERISTICS (4.75 ≤ V_{CC} ≤ 5.25 V, -40°C ≤ T_A ≤ 85°C, -40°C ≤ T_J ≤ 150°C; unless otherwise specified.)

Characteristic	Test Conditions	Min	Typ	Max	Unit
----------------	-----------------	-----	-----	-----	------

Supply Requirements

V _{CC} Quiescent Current	Output ON	-	3.0	6.0	mA
V _{CC} Quiescent Current	Output OFF	-	100	250	μA

Output

Leakage Current	V _{BAT} = 14 V	-	16	100	μA
Saturation Voltage	I _{OUTPUT} = 350 mA	-	1.1	1.5	V
	I _{OUTPUT} = 180 mA	-	0.9	1.3	V
V _{OUTPUT} (self-bias)	V _{CC} < 4.5 V, I _{OUTPUT} < 200 mA	-	-	3.5	V

Current Sense

Short Circuit Current	-	350	500	650	mA
Open Circuit Current	Output in the ON state	20	40	60	mA

Control-Input

Input Voltage	Logic = High	2.0	-	-	V
	Logic = Low	-	-	0.8	V
Input Current	Logic = V _{CC}	-	20	40	μA
	Logic = 0 V	-50	-20	-	μA

Fault Output – (Open Collector)

Output Low Voltage	I _{FAULT} = 250 μA (sink)	-	0.24	0.40	V
--------------------	------------------------------------	---	------	------	---

Overtemperature Shutdown

T _J Output Disable Threshold	(Guaranteed by Design)	150	180	-	°C
T _J Hysteresis	(Guaranteed by Design)	5.0	-	-	°C

Note: A fault signal will be shown (at the fault pin) during inrush as the short circuit threshold is exceeded.

PACKAGE PIN DESCRIPTION

PACKAGE PIN #	PIN SYMBOL	FUNCTION
8 Lead SO Narrow		
1	Output	Open collector output.
2	V _{CC}	5.0 V regulated supply input.
3	Fault	Open collector diagnostic output low during open load, short circuit and overtemperature conditions.
4	Control	TTL compatible input.
5, 6, 7, 8	Ground	Signal ground.

CS1108

CIRCUIT DESCRIPTION

The CS1108 lamp driver IC provides up to 350 mA of drive current in a low-side configuration. The Output driver pin is controlled through the TTL compatible Control input pin. A high condition on the Control pin turns the output pin on.

The $\overline{\text{Fault}}$ pin reports short circuit, open circuit, and overtemperature conditions on the IC. If a fault is present, the open collector output $\overline{\text{Fault}}$ pin will be low. Typical numbers for faults are: exceeding 500 mA of drive current will report a short circuit. Less than 40 mA (typical) will report an open circuit. A temperature fault will be reported when the die temperature exceeds 180°C (typical). Faults are only reported when the Control pin is high, due to the low quiescent current when the Control pin is low and the output device is turned off.

The CS1108 is designed to provide overcurrent protection by duty cycle control. When the lamp current exceeds the internally programmed current limit threshold (typically 500 mA), the output enters duty cycle mode to reduce power dissipation of the IC to a safe level.

Typical lamps have a low resistance when off and the current will exceed the current limit threshold during the initial inrush period. During this inrush time, the IC will be operating in the duty cycle mode. Due to characteristics of lamps in this mode, they may appear dimly lit. This condition will persist for a brief time until the lamp resistance has increased enough to reduce its current below the threshold. Once this occurs the lamp will appear at full brightness. During the inrush period the Fault pin will be forced low indicating that duty cycle mode is in operation.

Thermal protection has been designed into this IC. Should duty cycle mode operate for an extended amount of time and the power limitations of the IC are exceeded the IC die temperature will rise. Once the die temperature reaches the thermal temperature limit, the internal circuitry will shutoff the output and the lamp will turn off. Once the die temperature lowers below the thermal threshold, the output will be allowed to turn back on.

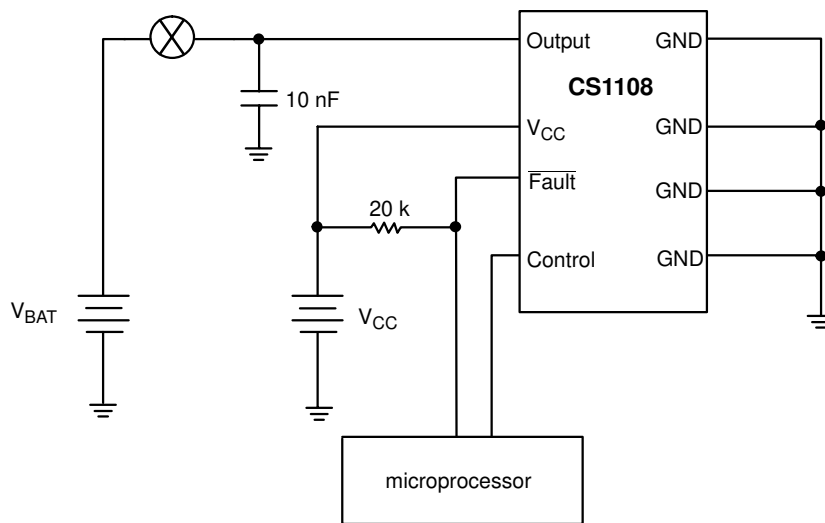
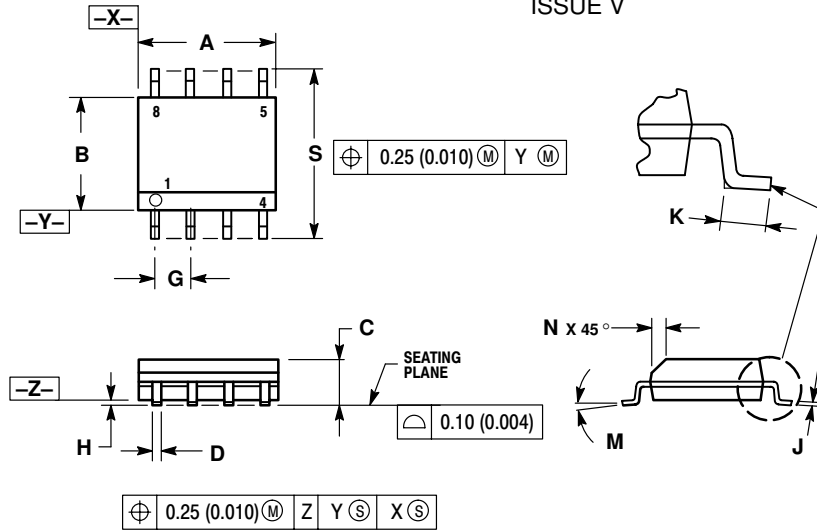

Figure 2. Applications Diagram

CS1108

PACKAGE DIMENSIONS

SO-8
DF SUFFIX
CASE 751-07
ISSUE V



DIM	MILLIMETERS		INCHES	
	MIN	MAX	MIN	MAX
A	4.80	5.00	0.189	0.197
B	3.80	4.00	0.150	0.157
C	1.35	1.75	0.053	0.069
D	0.33	0.51	0.013	0.020
G	1.27 BSC		0.050 BSC	
H	0.10	0.25	0.004	0.010
J	0.19	0.25	0.007	0.010
K	0.40	1.27	0.016	0.050
M	0°	8°	0°	8°
N	0.25	0.50	0.010	0.020
S	5.80	6.20	0.228	0.244

PACKAGE THERMAL DATA

Parameter		SO-8	Unit
R _{θJC}	Typical	25	°C/W
R _{θJA}	Typical	110	°C/W

ON Semiconductor and  are trademarks of Semiconductor Components Industries, LLC (SCILLC). SCILLC reserves the right to make changes without further notice to any products herein. SCILLC makes no warranty, representation or guarantee regarding the suitability of its products for any particular purpose, nor does SCILLC assume any liability arising out of the application or use of any product or circuit, and specifically disclaims any and all liability, including without limitation special, consequential or incidental damages. "Typical" parameters which may be provided in SCILLC data sheets and/or specifications can and do vary in different applications and actual performance may vary over time. All operating parameters, including "Typicals" must be validated for each customer application by customer's technical experts. SCILLC does not convey any license under its patent rights nor the rights of others. SCILLC products are not designed, intended, or authorized for use as components in systems intended for surgical implant into the body, or other applications intended to support or sustain life, or for any other application in which the failure of the SCILLC product could create a situation where personal injury or death may occur. Should Buyer purchase or use SCILLC products for any such unintended or unauthorized application, Buyer shall indemnify and hold SCILLC and its officers, employees, subsidiaries, affiliates, and distributors harmless against all claims, costs, damages, and expenses, and reasonable attorney fees arising out of, directly or indirectly, any claim of personal injury or death associated with such unintended or unauthorized use, even if such claim alleges that SCILLC was negligent regarding the design or manufacture of the part. SCILLC is an Equal Opportunity/Affirmative Action Employer.

PUBLICATION ORDERING INFORMATION

Literature Fulfillment:

Literature Distribution Center for ON Semiconductor
P.O. Box 5163, Denver, Colorado 80217 USA
Phone: 303-675-2175 or 800-344-3860 Toll Free USA/Canada
Fax: 303-675-2176 or 800-344-3867 Toll Free USA/Canada
Email: ONlit@hibbertco.com

N. American Technical Support: 800-282-9855 Toll Free USA/Canada

JAPAN: ON Semiconductor, Japan Customer Focus Center
4-32-1 Nishi-Gotanda, Shinagawa-ku, Tokyo, Japan 141-0031
Phone: 81-3-5740-2700
Email: r14525@onsemi.com

ON Semiconductor Website: <http://onsemi.com>

For additional information, please contact your local Sales Representative.