



Chipsmall Limited consists of a professional team with an average of over 10 year of expertise in the distribution of electronic components. Based in Hongkong, we have already established firm and mutual-benefit business relationships with customers from,Europe,America and south Asia,supplying obsolete and hard-to-find components to meet their specific needs.

With the principle of “Quality Parts,Customers Priority,Honest Operation,and Considerate Service”,our business mainly focus on the distribution of electronic components. Line cards we deal with include Microchip,ALPS,ROHM,Xilinx,Pulse,ON,Everlight and Freescale. Main products comprise IC,Modules,Potentiometer,IC Socket,Relay,Connector.Our parts cover such applications as commercial,industrial, and automotives areas.

We are looking forward to setting up business relationship with you and hope to provide you with the best service and solution. Let us make a better world for our industry!



## Contact us

Tel: +86-755-8981 8866 Fax: +86-755-8427 6832

Email & Skype: info@chipsmall.com Web: www.chipsmall.com

Address: A1208, Overseas Decoration Building, #122 Zhenhua RD., Futian, Shenzhen, China



# CS51411DEMO/D

## Demonstration Note for CS51411/3 5.0 V-16 V to 3.3 V/1.0 A Buck Regulator



ON Semiconductor™

<http://onsemi.com>

### DEMONSTRATION NOTE

#### Description

The CS51411 demonstration board is a 1.0 A/3.3 V buck regulator running at 260 kHz (CS51411) or 520 kHz (CS51413). The switching frequency can be synchronized to a higher frequency through feeding clock signals to the SYNC input. Driving SHDNB input low shuts down the converter output and minimizes the power consumption. The regulator has superior line and load regulation due to the use of V<sup>2</sup>™ control. This control method also enhances the load transient response.

#### Features

- V<sup>2</sup> Control for Superior Line and Load Regulation
- Small Board Space Requiring Only 1.0 × 0.7 in.<sup>2</sup>
- Total of 11 Components Including IC
- Shutdown Mode Disables the Output and Reduces the Operating Current
- Frequency Synchronization to Higher Frequency
- 1.5 A Peak Current Protection which Folds Back 30% During Overload Conditions
- Built-In Soft Start to Eliminate Any In-Rush Current
- High Energy Transfer Efficiency of 83% at 1.0 A Load
- Line Regulation Better Than 0.1%
- Load Regulation Better Than 0.4%



Figure 1. CS51411/3 Demonstration Board

# CS51411DEMO/D

## ABSOLUTE MAXIMUM RATINGS

Pin Name	Maximum Voltage	Maximum Current
V <sub>IN</sub>	16 V	2.0 A
V <sub>O</sub>	16 V	2.0 A
SHDNB	7.0 V	1.0 mA
SYNC	7.0 V	1.0 mA

## ELECTRICAL CHARACTERISTICS (T<sub>A</sub> = 25°C, 5.0 V ≤ V<sub>IN</sub> ≤ 16 V, 0.1 A ≤ I<sub>OUT</sub> ≤ 1.0 A, unless otherwise specified.)

Characteristic	Test Conditions	Typ	Unit
----------------	-----------------	-----	------

### Output Voltage

Voltage Accuracy	–	4.0	%
Line Regulation	I <sub>OUT</sub> = 1.0 A	0.1	%
Load Regulation	V <sub>IN</sub> = 5.0 V	0.3	%
Minimum Load	–	0.1	A
Transient Response	–	3.0	%
Transient Response Time	Load toggle between 0.1 A and 1.0 A	10	μs
Startup Time	–	5.0	ms

### Input Voltage

Start Threshold	–	3.3	V
-----------------	---	-----	---

### Sync and Shutdown

Sync Frequency	CS51411 CS51413	290 to 470 575 to 900	kHz kHz
Minimum Sync Threshold Voltage	–	1.0	V
Minimum Shutdown Threshold Voltage	–	0.3	V
Maximum Shutdown Bias Current	–	12	μA

### General

Switching Frequency	CS51411 CS51413	260 520	kHz kHz
Efficiency	I <sub>LOAD</sub> = 100 mA I <sub>LOAD</sub> = 1.0 A	77.5 83	% %
Shutdown Current	–	100	μA

## CS51411DEMO/D

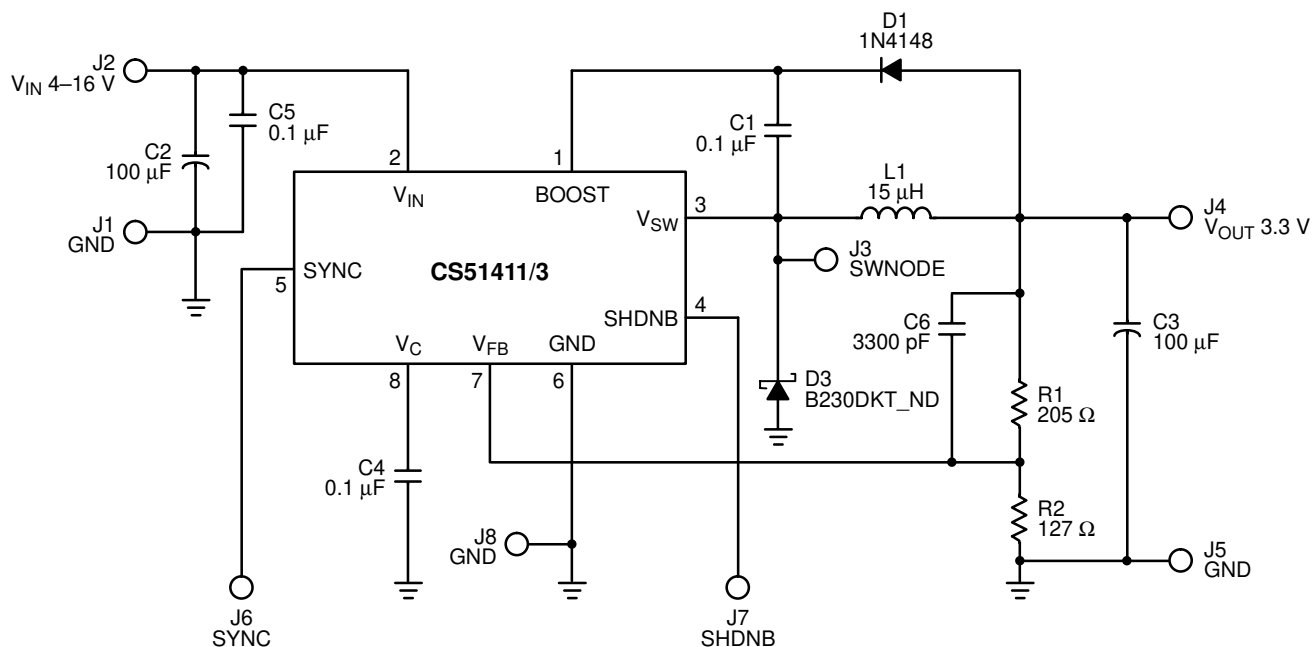

Figure 2. Application Diagram

### Operation Guidelines

1. Connect input voltage between J2 and J1 on the left side of the board. The maximum input voltage is limited by the voltage rating of the input capacitor.
2. Connect the load between J4 and J5. The regulator requires 100 mA as minimum load. Without this minimum load, the output may exceed the regulation voltage.
3. Connect shutdown signal between J7 and J8. When the voltage on this input is below 0.3 V, the regulator enters a sleep mode. Pull this input high or leave it open if not used.
4. The sync signal can be applied between J6 and J8. The amplitude of the sync pulses needs to be greater than 1.0 V. The duty cycle can vary from 10% to 90%. Leave it open if not used.

### Theory Of Operation

1. **Boost Strapping Circuit:** The boost strapping circuit, made of C1 and D1, provides a voltage higher than the input voltage to drive the power transistor (inside IC) into saturation. The operation of the boost strapping circuit works as follows. When the power transistor turns off, diode D3 turns on and pulls the V<sub>SW</sub> node to ground. Diode D1 is forward biased, and the output voltage charges C1 to V<sub>O</sub>. When the power transistor turns on, the V<sub>SW</sub> node is pulled high and is

approximately equal to V<sub>IN</sub>. Now the voltage of the Boost pin, which connects to C1, is equal to V<sub>IN</sub> + V<sub>O</sub>. Diode D1 is reverse biased. The Boost pin voltage provides adequate base current to the power transistor, which lowers V<sub>CE(SAT)</sub> and improves the energy transfer efficiency.

2. **Soft Start:** The soft-start is implemented on the V<sub>C</sub> pin. During the startup, the limited source current (25 μA) of the error amplifier charges the V<sub>C</sub> pin capacitor. The rising slope of the V<sub>C</sub> pin voltage clamps the duty cycle through the PWM comparator. The V<sub>C</sub> pin voltage eventually settles down to a voltage roughly equal to the reference voltage 1.27 V. Therefore, the startup time can be easily calculated.
3. **Feedback Network:** V<sup>2</sup> control relies on the output ripple to provide pulse width modulation. When the output ripple is inadequate, pulse skipping or instability may be observed. Adding a capacitor C6 in parallel with R1 provides a low impedance pass for the output ripple. Therefore, the output ripple is not attenuated by the resistor divider. The use of this capacitor is optional.

Please see data sheet for more description on regulator operation and component selection (document number CS51411/D available through the Literature Distribution Center or via our website at <http://www.onsemi.com>).

# CS51411DEMO/D

## TYPICAL PERFORMANCE CHARACTERISTICS

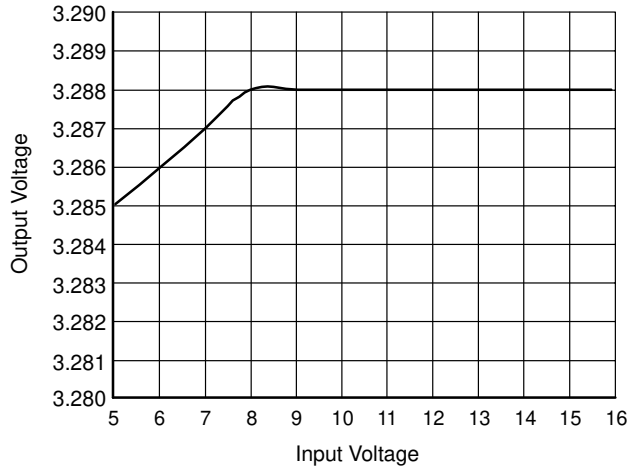

Figure 3. Line Regulation

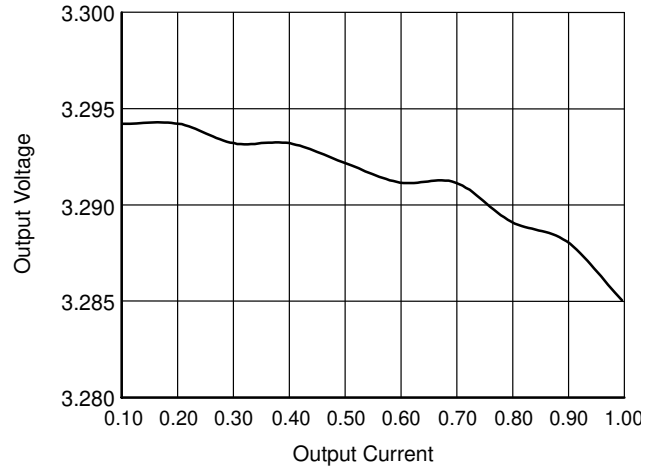

Figure 4. Load Regulation

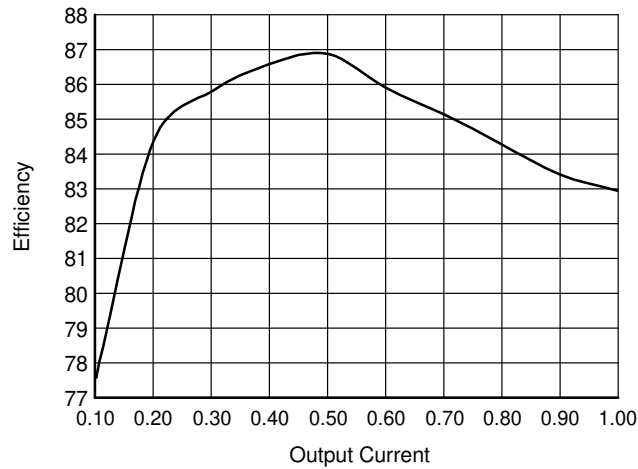

Figure 5. Efficiency vs. Output Current

### BILL OF MATERIALS

Ref. Designator	Vendor	Part Number	Type	PC/Board
C1, C4, C5	DIGIKEY	PCC1762CT-ND	0.1 $\mu$ F CERAMIC	3
C2, C3	AVX	TAJE107K016R	100 $\mu$ F TANTALUM	2
C6	DIGIKEY	PCC1778CT-ND	3300 pF CERAMIC	1
D1	DIGIKEY	LL4148CT-ND	DIODE	1
D3	DIGIKEY	B230DICT-ND	2.0 A SCHOTTKY	1
J1-J8	DIGIKEY	V1055	TEST POINT	8
L1	COILTRONICS	UP2.8B150	15 $\mu$ H INDUCTOR	1
R1	DIGIKEY	P205CTRND	205 $\Omega$ RESISTOR	1
R2	DIGIKEY	P127CTRND	127 $\Omega$ RESISTOR	1
U1	ON SEMICONDUCTOR	CS51411/3	CONTROLLER	1

# CS51411DEMO/D

## DRAWINGS OF LAYERS

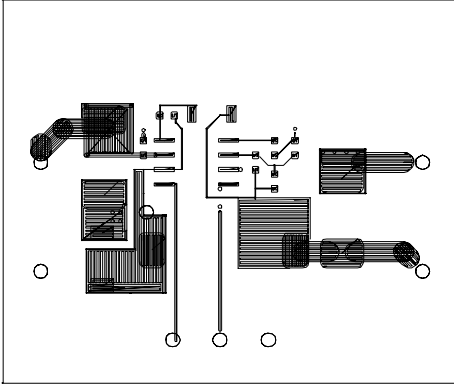

Figure 6. Top Copper

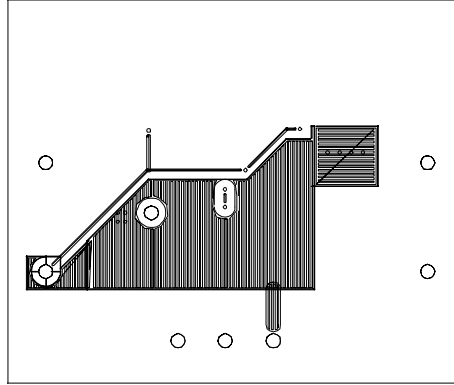

Figure 7. Bottom Copper

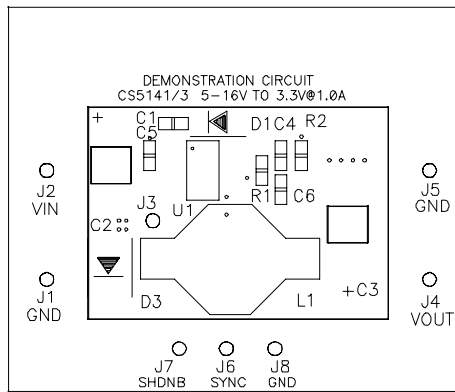



Figure 8. Top Silk

# Notes

# Notes



V<sup>2</sup> is a trademark of Switch Power, Inc.

**ON Semiconductor** and  are trademarks of Semiconductor Components Industries, LLC (SCILLC). SCILLC reserves the right to make changes without further notice to any products herein. SCILLC makes no warranty, representation or guarantee regarding the suitability of its products for any particular purpose, nor does SCILLC assume any liability arising out of the application or use of any product or circuit, and specifically disclaims any and all liability, including without limitation special, consequential or incidental damages. "Typical" parameters which may be provided in SCILLC data sheets and/or specifications can and do vary in different applications and actual performance may vary over time. All operating parameters, including "Typicals" must be validated for each customer application by customer's technical experts. SCILLC does not convey any license under its patent rights nor the rights of others. SCILLC products are not designed, intended, or authorized for use as components in systems intended for surgical implant into the body, or other applications intended to support or sustain life, or for any other application in which the failure of the SCILLC product could create a situation where personal injury or death may occur. Should Buyer purchase or use SCILLC products for any such unintended or unauthorized application, Buyer shall indemnify and hold SCILLC and its officers, employees, subsidiaries, affiliates, and distributors harmless against all claims, costs, damages, and expenses, and reasonable attorney fees arising out of, directly or indirectly, any claim of personal injury or death associated with such unintended or unauthorized use, even if such claim alleges that SCILLC was negligent regarding the design or manufacture of the part. SCILLC is an Equal Opportunity/Affirmative Action Employer.

## PUBLICATION ORDERING INFORMATION

### Literature Fulfillment:

Literature Distribution Center for ON Semiconductor  
P.O. Box 5163, Denver, Colorado 80217 USA  
**Phone:** 303-675-2175 or 800-344-3860 Toll Free USA/Canada  
**Fax:** 303-675-2176 or 800-344-3867 Toll Free USA/Canada  
**Email:** ONlit@hibbertco.com

**N. American Technical Support:** 800-282-9855 Toll Free USA/Canada

**JAPAN:** ON Semiconductor, Japan Customer Focus Center  
4-32-1 Nishi-Gotanda, Shinagawa-ku, Tokyo, Japan 141-0031  
**Phone:** 81-3-5740-2700  
**Email:** r14525@onsemi.com

**ON Semiconductor Website:** <http://onsemi.com>

For additional information, please contact your local Sales Representative.