



Chipsmall Limited consists of a professional team with an average of over 10 year of expertise in the distribution of electronic components. Based in Hongkong, we have already established firm and mutual-benefit business relationships with customers from,Europe,America and south Asia,supplying obsolete and hard-to-find components to meet their specific needs.

With the principle of “Quality Parts,Customers Priority,Honest Operation,and Considerate Service”,our business mainly focus on the distribution of electronic components. Line cards we deal with include Microchip,ALPS,ROHM,Xilinx,Pulse,ON,Everlight and Freescale. Main products comprise IC,Modules,Potentiometer,IC Socket,Relay,Connector.Our parts cover such applications as commercial,industrial, and automotives areas.

We are looking forward to setting up business relationship with you and hope to provide you with the best service and solution. Let us make a better world for our industry!



Contact us

Tel: +86-755-8981 8866 Fax: +86-755-8427 6832

Email & Skype: info@chipsmall.com Web: www.chipsmall.com

Address: A1208, Overseas Decoration Building, #122 Zhenhua RD., Futian, Shenzhen, China



CS5203A-1, CS5203A-2, CS5203A-3, CS5203A-5



ON Semiconductor®

<http://onsemi.com>

3.0 A Adjustable, and Fixed 1.5 V, 3.3 V and 5.0 V Linear Regulators

The CS5203A series of linear regulators provides 3.0 A at adjustable and fixed voltages with an accuracy of $\pm 1.0\%$ and $\pm 2.0\%$ respectively. The adjustable version uses two external resistors to set the output voltage within a 1.25 V to 13 V range.

The regulators are intended for use as post regulators and microprocessor supplies. The fast loop response and low dropout voltage make these regulators ideal for applications where low voltage operation and good transient response are important.

The circuit is designed to operate with dropout voltages as low as 1.0 V depending on the output current level. The maximum quiescent current is only 10 mA at full load.

The regulators are fully protected against overload conditions with protection circuitry for Safe Operating Area (SOA), overcurrent and thermal shutdown.

The CS5203A is pin compatible with the LT1085 family of linear regulators but has lower dropout voltage.

The regulators are available in TO-220-3 and surface mount D²PAK-3 packages.

Features

- Pb-Free Package is Available
- Output Current to 3.0 A
- Output Trimmed to $\pm 1.0\%$
- Dropout Voltage 1.05 V @ 3.0 A
- Fast Transient Response
- Fault Protection Circuitry
 - ◆ Thermal Shutdown
 - ◆ Overcurrent Protection
 - ◆ Safe Area Protection

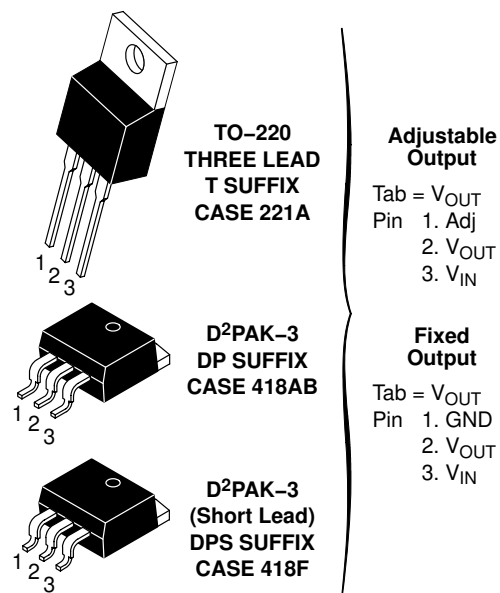

ORDERING INFORMATION

See detailed ordering and shipping information in the package dimensions section on page 8 of this data sheet.

DEVICE MARKING INFORMATION

See general marking information in the device marking section on page 8 of this data sheet.

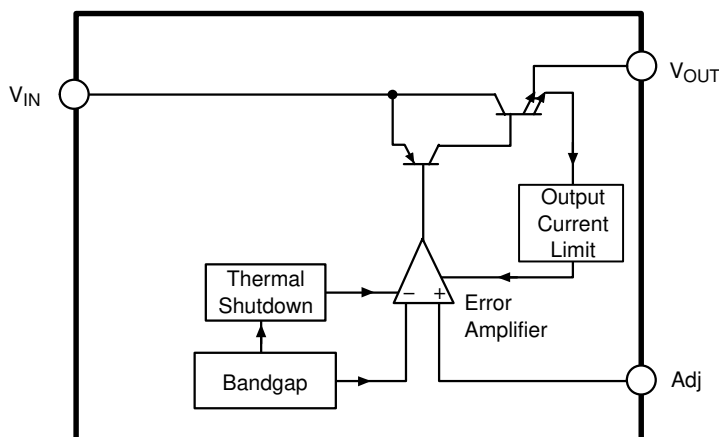

Figure 1. Block Diagram – CS5203A-1

CS5203A-1, CS5203A-2, CS5203A-3, CS5203A-5

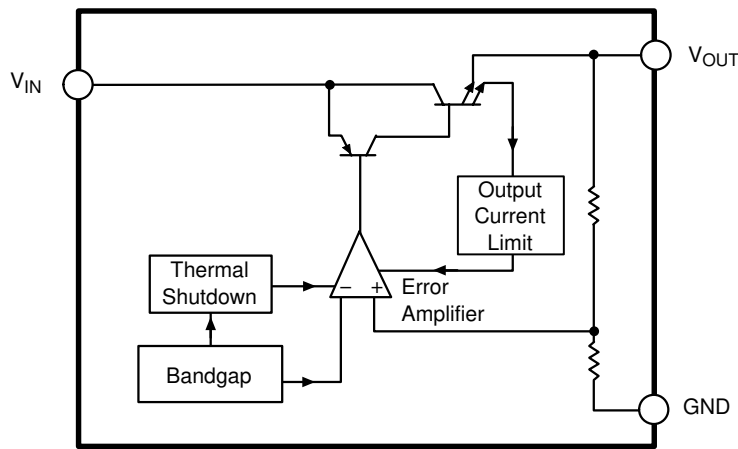

Figure 2. Block Diagram – CS5203A-2, -3, -5

MAXIMUM RATINGS

Parameter	Value	Unit	
Supply Voltage, V_{CC}	17	V	
Operating Temperature Range	-40 to +70	°C	
Junction Temperature	150	°C	
Storage Temperature Range	-60 to +150	°C	
Lead Temperature Soldering:	Wave Solder (through hole styles only) (Note 1) Reflow (SMD styles only) (Note 2)	260 Peak 230 Peak	°C

Maximum ratings are those values beyond which device damage can occur. Maximum ratings applied to the device are individual stress limit values (not normal operating conditions) and are not valid simultaneously. If these limits are exceeded, device functional operation is not implied, damage may occur and reliability may be affected.

- 10 second maximum.
- 60 second maximum above 183°C.

ELECTRICAL CHARACTERISTICS ($C_{IN} = 10 \mu\text{F}$, $C_{OUT} = 22 \mu\text{F}$ Tantalum, $V_{IN} - V_{OUT} = 3.0 \text{ V}$, $V_{IN} \leq 15 \text{ V}$, $0^\circ\text{C} \leq T_A \leq 70^\circ\text{C}$, $T_J \leq +150^\circ\text{C}$, unless otherwise specified, $I_{full\ load} = 3.0 \text{ A}$.)

Characteristic	Test Conditions	Min	Typ	Max	Unit
Adjustable Output Voltage (CS5203A-1)					
Reference Voltage (Notes 3 and 4)	$V_{IN} - V_{OUT} = 1.5 \text{ V}$; $V_{Adj} = 0 \text{ V}$, $10 \text{ mA} \leq I_{OUT} \leq 3.0 \text{ A}$	1.241 (-1%)	1.254	1.266 (+1%)	V
Line Regulation	$1.5 \text{ V} \leq V_{IN} - V_{OUT} \leq 6.0 \text{ V}$; $I_{OUT} = 10 \text{ mA}$	-	0.04	0.20	%
Load Regulation (Notes 3 and 4)	$V_{IN} - V_{OUT} = 1.5 \text{ V}$; $10 \text{ mA} \leq I_{OUT} \leq 3.0 \text{ A}$	-	0.03	0.4	%
Dropout Voltage (Note 5)	$I_{OUT} = 3.0 \text{ A}$	-	1.05	1.15	V
Current Limit	$V_{IN} - V_{OUT} = 3.0 \text{ V}$; $T_J \geq 25^\circ\text{C}$ $V_{IN} - V_{OUT} = 15 \text{ V}$	3.2 -	5.5 2.5	- -	A A
Minimum Load Current	$V_{IN} - V_{OUT} = 7.0 \text{ V}$	-	1.2	6.0	mA
Adjust Pin Current	-	-	50	100	μA
Adjust Pin Current Change	$1.5 \text{ V} \leq V_{IN} - V_{OUT} \leq 4.0 \text{ V}$; $10 \text{ mA} \leq I_{OUT} \leq 3.0 \text{ A}$	-	0.2	5.0	μA
Thermal Regulation	30 ms pulse; $T_A = 25^\circ\text{C}$	-	0.003	-	%/W

3. Load regulation and output voltage are measured at a constant junction temperature by low duty cycle pulse testing. Changes in output voltage due to thermal gradients or temperature changes must be taken into account separately.
4. Specifications apply for an external Kelvin sense connection at a point on the output pin 1/4" from the bottom of the package.
5. Dropout voltage is a measurement of the minimum input/output differential at full load.

CS5203A-1, CS5203A-2, CS5203A-3, CS5203A-5

ELECTRICAL CHARACTERISTICS (continued) ($C_{IN} = 10 \mu\text{F}$, $C_{OUT} = 22 \mu\text{F}$ Tantalum, $V_{IN} - V_{OUT} = 3.0 \text{ V}$, $V_{IN} \leq 15 \text{ V}$, $0^\circ\text{C} \leq T_A \leq 70^\circ\text{C}$, $T_J \leq +150^\circ\text{C}$, unless otherwise specified, $I_{full\ load} = 3.0 \text{ A}$.)

Characteristic	Test Conditions	Min	Typ	Max	Unit
Adjustable Output Voltage (CS5203A-1) (continued)					
Ripple Rejection	$f = 120 \text{ Hz}$; $C_{Adj} = 25 \mu\text{F}$; $I_{OUT} = 3.0 \text{ A}$	–	85	–	dB
Temperature Stability	–	–	0.5	–	%
RMS Output Noise	$10 \text{ Hz} \leq f \leq 10 \text{ kHz}$; $T_A = 25^\circ\text{C}$	–	0.003	–	% V_{OUT}
Thermal Shutdown	–	150	180	–	$^\circ\text{C}$
Thermal Shutdown Hysteresis	–	–	25	–	$^\circ\text{C}$

ELECTRICAL CHARACTERISTICS ($C_{IN} = 10 \mu\text{F}$, $C_{OUT} = 22 \mu\text{F}$ Tantalum, $V_{IN} - V_{OUT} = 3.0 \text{ V}$, $V_{IN} \leq 15 \text{ V}$, $0^\circ\text{C} \leq T_A \leq 70^\circ\text{C}$, $T_J \leq +150^\circ\text{C}$, unless otherwise specified, $I_{full\ load} = 3.0 \text{ A}$.)

Characteristic	Test Conditions	Min	Typ	Max	Unit
Fixed Output Voltage (CS5203A-2, CS5203A-3, CS5203A-5)					
Reference Voltage (Notes 6 and 7)					
CS5203A-5	$V_{IN} - V_{OUT} = 1.5 \text{ V}$; $0 \leq I_{OUT} \leq 3.0 \text{ A}$	4.9 (–2%)	5.0	5.1 (+2%)	V
CS5203A-3	$V_{IN} - V_{OUT} = 1.5 \text{ V}$; $0 \leq I_{OUT} \leq 3.0 \text{ A}$	3.234 (–2%)	3.3	3.366 (+2%)	V
CS5203A-2	$V_{IN} - V_{OUT} = 1.5 \text{ V}$; $0 \leq I_{OUT} \leq 3.0 \text{ A}$	1.47 (–2%)	1.5	1.53 (+2%)	V
Line Regulation	$1.5 \text{ V} \leq V_{IN} - V_{OUT} \leq 6.0 \text{ V}$; $I_{OUT} = 10 \text{ mA}$	–	0.04	0.20	%
Load Regulation (Notes 6 and 7)	$V_{IN} - V_{OUT} = 1.5 \text{ V}$; $10 \text{ mA} \leq I_{OUT} \leq 3.0 \text{ A}$	–	0.03	0.4	%
Dropout Voltage (Note 8)	$I_{OUT} = 3.0 \text{ A}$	–	1.05	1.15	V
Current Limit	$V_{IN} - V_{OUT} = 3.0 \text{ V}$; $T_J \geq 25^\circ\text{C}$ $V_{IN} - V_{OUT} = 15 \text{ V}$	3.2 –	5.5 2.5	– –	A A
Quiescent Current	$V_{IN} \leq 9.0 \text{ V}$; $I_{OUT} = 10 \text{ mA}$	–	5.0	10	mA
Thermal Regulation	30 ms pulse; $T_A = 25^\circ\text{C}$	–	0.003	–	%/W
Ripple Rejection	$f = 120 \text{ Hz}$; $I_{OUT} = 3.0 \text{ A}$	–	78	–	dB
Temperature Stability	–	–	0.5	–	%
RMS Output Noise (% V_{OUT})	$10 \text{ Hz} \leq f \leq 10 \text{ kHz}$	–	0.003	–	% V_{OUT}
Thermal Shutdown	–	150	180	–	$^\circ\text{C}$
Thermal Shutdown Hysteresis	–	–	25	–	$^\circ\text{C}$

6. Load regulation and output voltage are measured at a constant junction temperature by low duty cycle pulse testing. Changes in output voltage due to thermal gradients or temperature changes must be taken into account separately.
7. Specifications apply for an external Kelvin sense connection at a point on the output pin 1/4" from the bottom of the package.
8. Dropout voltage is a measurement of the minimum input/output differential at full load.

PACKAGE PIN DESCRIPTION

Package Pin Number				Pin Symbol	Function
CS5203A-1		CS5203A-2, -3, -5			
D ² PAK-3	TO-220-3	D ² PAK-3	TO-220-3		
1	1	N/A	N/A	Adj	Adjust pin (low side of the internal reference).
2	2	2	2	V_{OUT}	Regulated output voltage (case).
3	3	3	3	V_{IN}	Input voltage.
N/A	N/A	1	1	GND	Ground connection.

TYPICAL PERFORMANCE CHARACTERISTICS

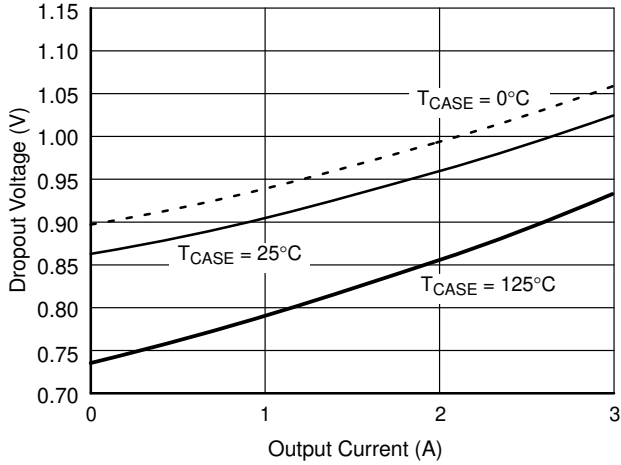

Figure 3. Dropout Voltage vs. Output Current

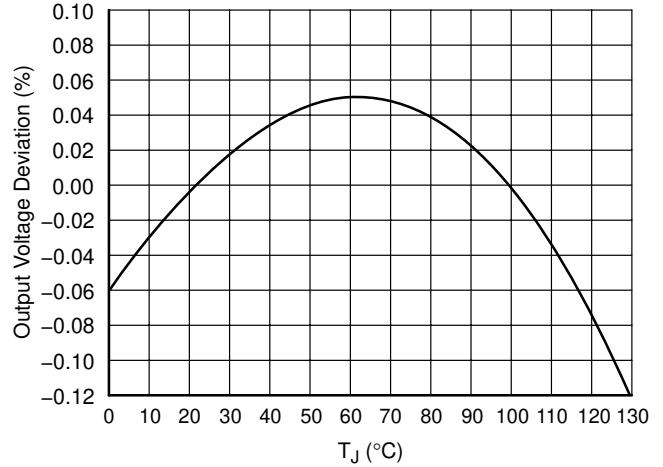

Figure 4. Reference Voltage vs. Temperature

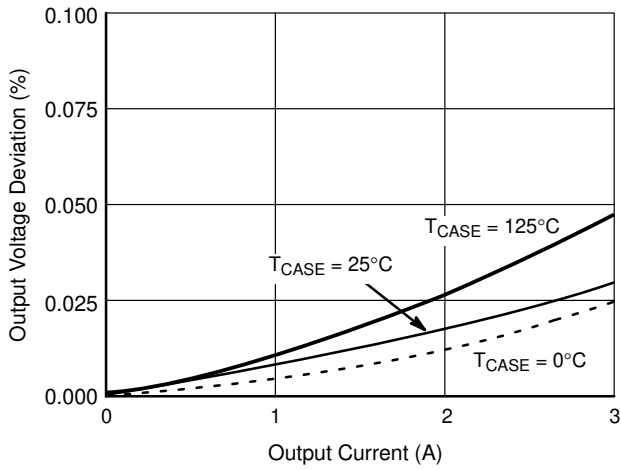

Figure 5. Load Regulation vs. Output Current

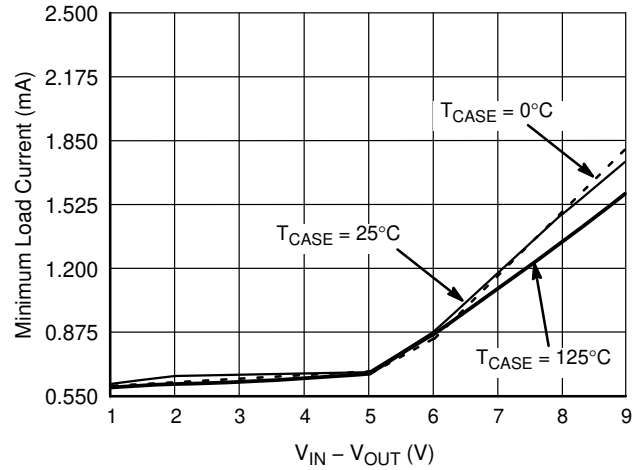

Figure 6. Minimum Load Current

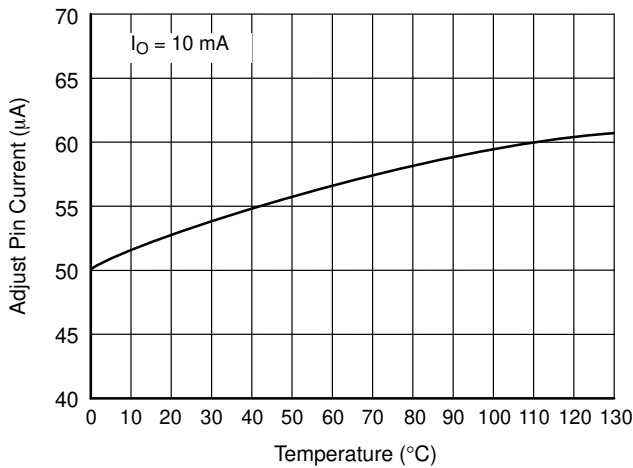

Figure 7. Adjust Pin Current vs. Temperature

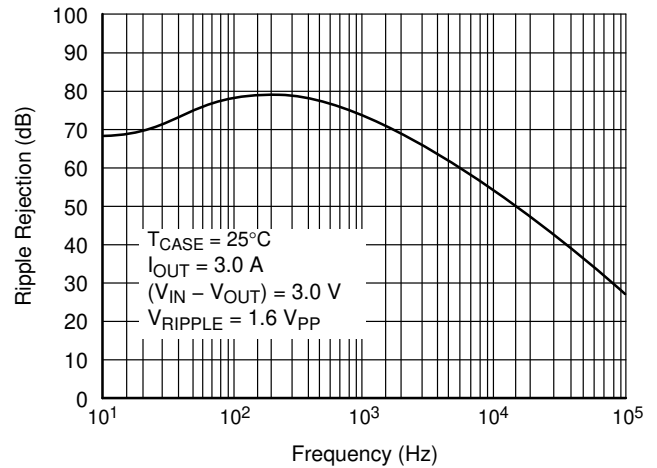

Figure 8. Ripple Rejection vs. Frequency (Fixed Versions)

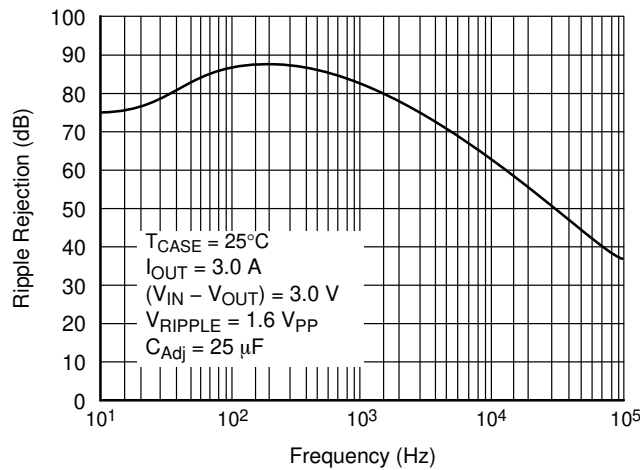

Figure 9. Ripple Rejection vs. Frequency (Adjustable Versions)

APPLICATIONS INFORMATION

The CS5203A family of linear regulators provides fixed or adjustable voltages at currents up to 3.0 A. The regulators are protected against short circuit, and include thermal shutdown and safe area protection (SOA) circuitry. The SOA protection circuitry decreases the maximum available output current as the input–output differential voltage increases.

The CS5203A has a composite PNP–NPN output transistor and requires an output capacitor for stability. A detailed procedure for selecting this capacitor is included in the Stability Considerations section.

Adjustable Operation

The adjustable regulator (CS5203A-1) has an output voltage range of 1.25 V to 13 V. An external resistor divider sets the output voltage as shown in Figure 10. The regulator maintains a fixed 1.25 V (typical) reference between the output pin and the adjust pin.

A resistor divider network R1 and R2 causes a fixed current to flow to ground. This current creates a voltage across R2 that adds to the 1.25 V across R1 and sets the overall output voltage. The adjust pin current (typically 50 μA) also flows through R2 and adds a small error that should be taken into account if precise adjustment of V_{OUT} is necessary.

The output voltage is set according to the formula:

$$V_{OUT} = V_{REF} \times \left(\frac{R_1 + R_2}{R_1} \right) + I_{Adj} \times R_2$$

The term $I_{Adj} \times R_2$ represents the error added by the adjust pin current.

R1 is chosen so that the minimum load current is at least 10 mA. R1 and R2 should be the same type, e.g. metal film for best tracking over temperature. The adjust pin is bypassed to improve the transient response and ripple rejection of the regulator.

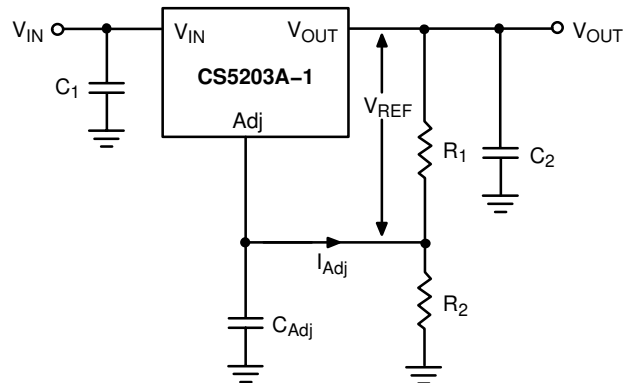

Figure 10. Resistor Divider Scheme for the Adjustable Version

Stability Considerations

The output or compensation capacitor helps determine three main characteristics of a linear regulator: startup delay, load transient response and loop stability.

The capacitor value and type is based on cost, availability, size and temperature constraints. A tantalum or aluminum electrolytic capacitor is best, since a film or ceramic capacitor with almost zero ESR, can cause instability. The aluminum electrolytic capacitor is the least expensive solution. However, when the circuit operates at low temperatures, both the value and ESR of the capacitor will vary considerably. The capacitor manufacturers data sheet provides this information.

A 22 μF tantalum capacitor will work for most applications, but with high current regulators such as the CS5203A the transient response and stability improve with higher values of capacitor. The majority of applications for this regulator involve large changes in load current so the output capacitor must supply the instantaneous load current.

CS5203A-1, CS5203A-2, CS5203A-3, CS5203A-5

The ESR of the output capacitor causes an immediate drop in output voltage given by:

$$\Delta V = \Delta I \times \text{ESR}$$

For microprocessor applications it is customary to use an output capacitor network consisting of several tantalum and ceramic capacitors in parallel. This reduces the overall ESR and reduces the instantaneous output voltage drop under load transient conditions. The output capacitor network should be as close as possible to the load for the best results.

Protection Diodes

When large external capacitors are used with a linear regulator it is sometimes necessary to add protection diodes. If the input voltage of the regulator gets shorted, the output capacitor will discharge into the output of the regulator. The discharge current depends on the value of the capacitor, the output voltage and the rate at which V_{IN} drops. In the CS5203A-X family of linear regulators, the discharge path is through a large junction and protection diodes are not usually needed. If the regulator is used with large values of output capacitance and the input voltage is instantaneously shorted to ground, damage can occur. In this case, a diode connected as shown in Figures 11 and 12 is recommended.

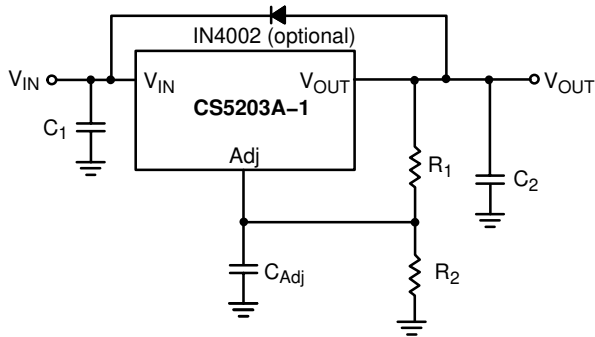

Figure 11. Protection Diode Scheme for Adjustable Output Regulator

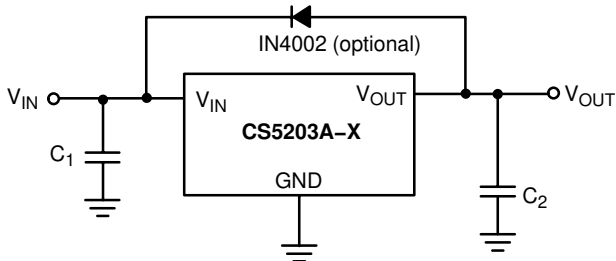

Figure 12. Protection Diode Scheme for Fixed Output Regulators

Output Voltage Sensing

Since the CS5203A is a three terminal regulator, it is not possible to provide true remote load sensing. Load regulation is limited by the resistance of the conductors connecting the regulator to the load. For best results the fixed regulators should be connected as shown in Figure 13.

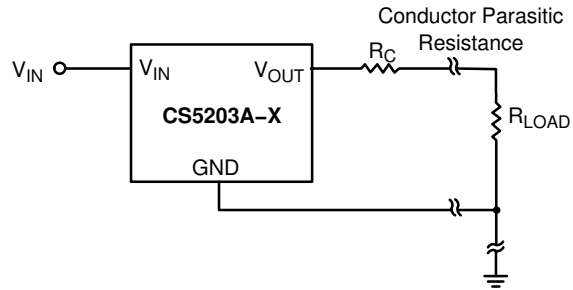

Figure 13. Conductor Parasitic Resistance can be Minimized with the Above Grounding Scheme for Fixed Output Regulators

For the adjustable regulator, the best load regulation occurs when $R1$ is connected directly to the output pin of the regulator as shown in Figure 14. If $R1$ is connected to the load, R_C is multiplied by the divider ratio and the effective resistance between the regulator and the load becomes

$$R_C \times \left(\frac{R1 + R2}{R1} \right)$$

where R_C = conductor parasitic resistance.

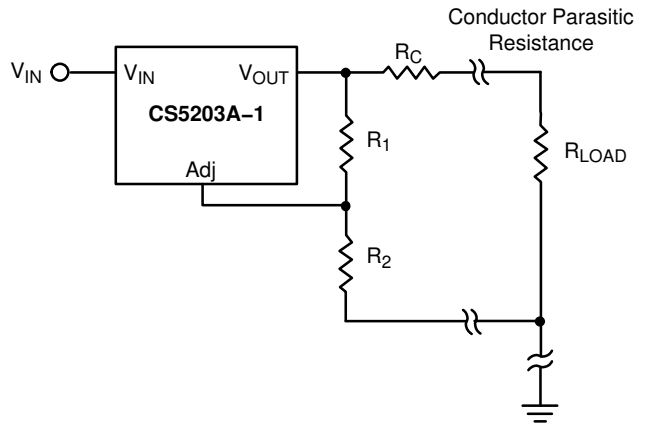

Figure 14. Grounding Scheme for Adjustable Output Regulator to Minimize Parasitics

Calculating Power Dissipation and Heatsink Requirements

The CS5203A series of linear regulators includes thermal shutdown and current limit circuitry to protect the device. High power regulators such as these usually operate at high junction temperatures so it is important to calculate the power dissipation and junction temperatures accurately to ensure that an adequate Heatsink is used.

The case is connected to V_{OUT} on the CS5203A, electrical isolation may be required for some applications. Thermal compound should always be used with high current regulators such as these.

The thermal characteristics of an IC depend on the following four factors:

1. Maximum Ambient Temperature T_A (°C)
2. Power dissipation P_D (Watts)
3. Maximum junction temperature T_J (°C)
4. Thermal resistance junction to ambient $R_{\theta JA}$ (°C/W)

These four are related by the equation

$$T_J = T_A + P_D \times R_{\theta JA} \quad (1)$$

The maximum ambient temperature and the power dissipation are determined by the design while the maximum junction temperature and the thermal resistance depend on the manufacturer and the package type.

The maximum power dissipation for a regulator is:

$$P_{D(max)} = \{V_{IN(max)} - V_{OUT(min)}\}I_{OUT(max)} + V_{IN(max)}I_Q \quad (2)$$

where:

$V_{IN(max)}$ is the maximum input voltage,

$V_{OUT(min)}$ is the minimum output voltage,

$I_{OUT(max)}$ is the maximum output current, for the application

I_Q is the maximum quiescent current at $I_{OUT(max)}$.

A Heatsink effectively increases the surface area of the package to improve the flow of heat away from the IC and into the surrounding air.

Each material in the heat flow path between the IC and the outside environment has a thermal resistance. Like series electrical resistances, these resistances are summed to determine $R_{\theta JA}$, the total thermal resistance between the junction and the surrounding air.

1. Thermal Resistance of the junction-to-case, $R_{\theta JC}$ (°C/W)
2. Thermal Resistance of the case to Heatsink, $R_{\theta CS}$ (°C/W)
3. Thermal Resistance of the Heatsink to the ambient air, $R_{\theta SA}$ (°C/W)

These are connected by the equation:

$$R_{\theta JA} = R_{\theta JC} + R_{\theta CS} + R_{\theta SA} \quad (3)$$

The value for $R_{\theta JA}$ is calculated using equation (3) and the result can be substituted in equation (1).

The value for $R_{\theta JC}$ is normally quoted as a single figure for a given package type based on an average die size. For a high current regulator such as the CS5203A the majority of the heat is generated in the power transistor section. The value for $R_{\theta SA}$ depends on the Heatsink type, while $R_{\theta CS}$ depends on factors such as package type, Heatsink interface (is an insulator and thermal grease used?), and the contact area between the Heatsink and the package. Once these calculations are complete, the maximum permissible value of $R_{\theta JA}$ can be calculated and the proper Heatsink selected. For further discussion on Heatsink selection, see application note “Thermal Management,” document number AND8036/D, available through the Literature Distribution Center or via our website at <http://onsemi.com>.

CS5203A-1, CS5203A-2, CS5203A-3, CS5203A-5

ORDERING INFORMATION

Device	Type	Package	Shipping†
CS5203A-1GT3	3.0 A, Adj. Output	TO-220-3, STRAIGHT	50 Units / Rail
CS5203A-1GDP3	3.0 A, Adj. Output	D ² PAK-3	50 Units / Rail
CS5203A-1GDPR3	3.0 A, Adj. Output	D ² PAK-3	750 / Tape & Reel
CS5203A-2GT3	3.0 A, 1.5 V Output	TO-220-3, STRAIGHT	50 Units / Rail
CS5203A-2GDP3	3.0 A, 1.5 V Output	D ² PAK-3	50 Units / Rail
CS5203A-2GDPR3	3.0 A, 1.5 V Output	D ² PAK-3	750 / Tape & Reel
CS5203A-2GDPR3G	3.0 A, 1.5 V Output	D ² PAK-3 (Pb-Free)	750 / Tape & Reel
CS5203A-2GDPSR3	3.0 A, 1.5 V Output	D ² PAK-3	750 / Tape & Reel
CS5203A-3GT3	3.0 A, 3.3 V Output	TO-220-3, STRAIGHT	50 Units / Rail
CS5203A-3GDP3	3.0 A, 3.3 V Output	D ² PAK-3	50 Units / Rail
CS5203A-3GDPR3	3.0 A, 3.3 V Output	D ² PAK-3	750 / Tape & Reel
CS5203A-3GDPSR3	3.0 A, 3.3 V Output	D ² PAK-3	750 / Tape & Reel
CS5203A-5GT3	3.0 A, 5.0 V Output	TO-220-3, STRAIGHT	50 Units / Rail

†For information on tape and reel specifications, including part orientation and tape sizes, please refer to our Tape and Reel Packaging Specifications Brochure, BRD8011/D.

MARKING DIAGRAMS

TO-220-3
T SUFFIX
CASE 221A

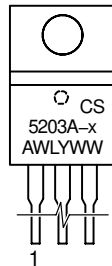

D²PAK-3
DP SUFFIX
CASE 418AB

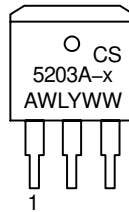

D²PAK-3
DPS SUFFIX
CASE 418F

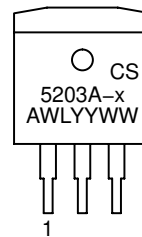

x = 1, 2, 3, or 5
A = Assembly Location
WL, L = Wafer Lot
YY, Y = Year
WW, W = Work Week

PACKAGE THERMAL DATA

Parameter		TO-220-3	D ² PAK-3	Unit
R _{θJC}	Typical	1.6	1.6	°C/W
R _{θJA}	Typical	50	10-50*	°C/W

*Depending on thermal properties of substrate. R_{θJA} = R_{θJC} + R_{θCA}.

PACKAGE DIMENSIONS

TO-220-3
T SUFFIX
CASE 221A-08
ISSUE AA

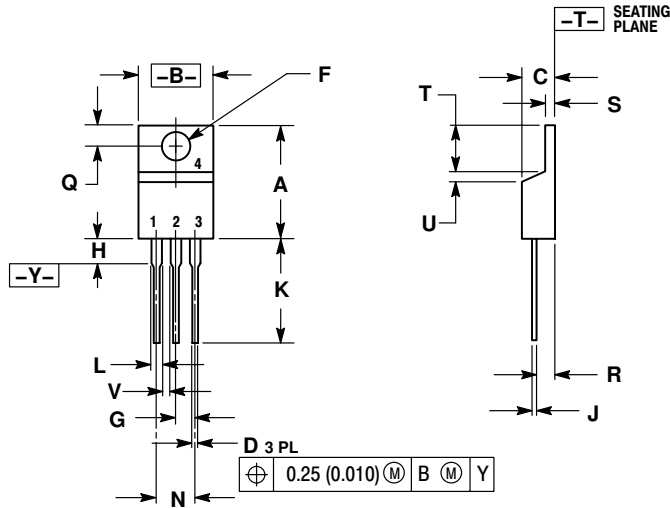

- NOTES:
1. DIMENSIONING AND TOLERANCING PER ANSI Y14.5M, 1982.
2. CONTROLLING DIMENSION: INCH.

DIM	INCHES		MILLIMETERS	
	MIN	MAX	MIN	MAX
A	0.560	0.625	14.23	15.87
B	0.380	0.420	9.66	10.66
C	0.140	0.190	3.56	4.82
D	0.025	0.035	0.64	0.89
F	0.139	0.155	3.53	3.93
G	0.100 BSC		2.54 BSC	
H	---	0.280	---	7.11
J	0.012	0.045	0.31	1.14
K	0.500	0.580	12.70	14.73
L	0.045	0.060	1.15	1.52
N	0.200 BSC		5.08 BSC	
Q	0.100	0.135	2.54	3.42
R	0.080	0.115	2.04	2.92
S	0.020	0.055	0.51	1.39
T	0.235	0.255	5.97	6.47
U	0.000	0.050	0.00	1.27
V	0.045	---	1.15	---

D²PAK-3
DP SUFFIX
CASE 418AB-01
ISSUE O

**For D²PAK Outline and
Dimensions – Contact Factory**

CS5203A-1, CS5203A-2, CS5203A-3, CS5203A-5

PACKAGE DIMENSIONS

**D²PAK-3
DPS SUFFIX
CASE 418F-01
ISSUE O**

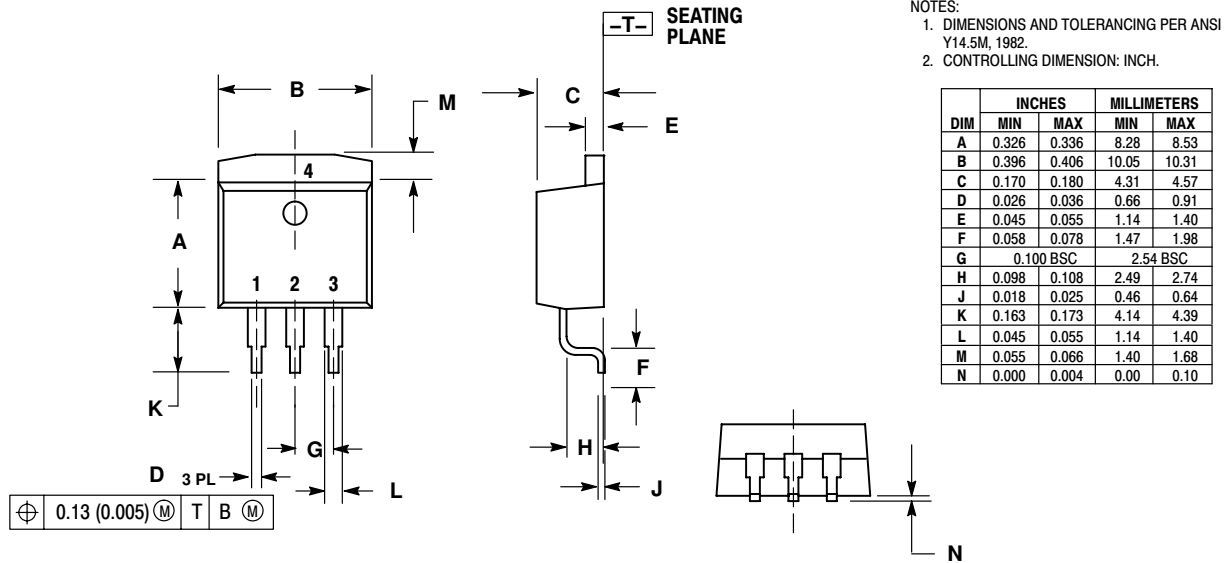

SOLDERING FOOTPRINT*

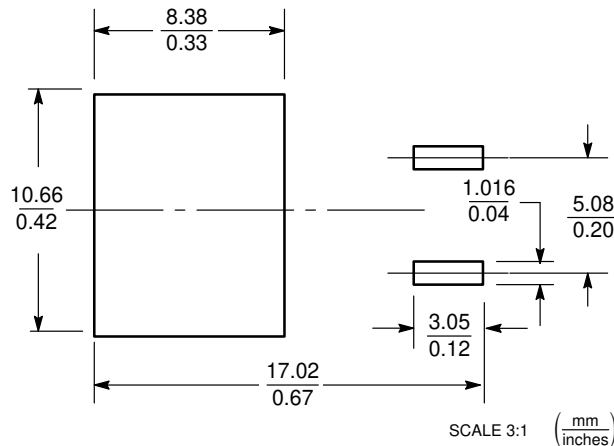

*For additional information on our Pb-Free strategy and soldering details, please download the ON Semiconductor Soldering and Mounting Techniques Reference Manual, SOLDERRM/D.

ON Semiconductor and are registered trademarks of Semiconductor Components Industries, LLC (SCILLC). SCILLC reserves the right to make changes without further notice to any products herein. SCILLC makes no warranty, representation or guarantee regarding the suitability of its products for any particular purpose, nor does SCILLC assume any liability arising out of the application or use of any product or circuit, and specifically disclaims any and all liability, including without limitation special, consequential or incidental damages. "Typical" parameters which may be provided in SCILLC data sheets and/or specifications can and do vary in different applications and actual performance may vary over time. All operating parameters, including "Typicals" must be validated for each customer application by customer's technical experts. SCILLC does not convey any license under its patent rights nor the rights of others. SCILLC products are not designed, intended, or authorized for use as components in systems intended for surgical implant into the body, or other applications intended to support or sustain life, or for any other application in which the failure of the SCILLC product could create a situation where personal injury or death may occur. Should Buyer purchase or use SCILLC products for any such unintended or unauthorized application, Buyer shall indemnify and hold SCILLC and its officers, employees, subsidiaries, affiliates, and distributors harmless against all claims, costs, damages, and expenses, and reasonable attorney fees arising out of, directly or indirectly, any claim of personal injury or death associated with such unintended or unauthorized use, even if such claim alleges that SCILLC was negligent regarding the design or manufacture of the part. SCILLC is an Equal Opportunity/Affirmative Action Employer. This literature is subject to all applicable copyright laws and is not for resale in any manner.

PUBLICATION ORDERING INFORMATION

LITERATURE FULFILLMENT:

Literature Distribution Center for ON Semiconductor
P.O. Box 61312, Phoenix, Arizona 85082-1312 USA
Phone: 480-829-7710 or 800-344-3860 Toll Free USA/Canada
Fax: 480-829-7709 or 800-344-3867 Toll Free USA/Canada
Email: orderlit@onsemi.com

N. American Technical Support: 800-282-9855 Toll Free
USA/Canada

Japan: ON Semiconductor, Japan Customer Focus Center
2-9-1 Kamimeguro, Meguro-ku, Tokyo, Japan 153-0051
Phone: 81-3-5773-3850

ON Semiconductor Website: <http://onsemi.com>

Order Literature: <http://www.onsemi.com/litorder>

For additional information, please contact your local Sales Representative.