



Chipsmall Limited consists of a professional team with an average of over 10 year of expertise in the distribution of electronic components. Based in Hongkong, we have already established firm and mutual-benefit business relationships with customers from,Europe,America and south Asia,supplying obsolete and hard-to-find components to meet their specific needs.

With the principle of “Quality Parts,Customers Priority,Honest Operation,and Considerate Service”,our business mainly focus on the distribution of electronic components. Line cards we deal with include Microchip,ALPS,ROHM,Xilinx,Pulse,ON,Everlight and Freescale. Main products comprise IC,Modules,Potentiometer,IC Socket,Relay,Connector.Our parts cover such applications as commercial,industrial, and automotives areas.

We are looking forward to setting up business relationship with you and hope to provide you with the best service and solution. Let us make a better world for our industry!



Contact us

Tel: +86-755-8981 8866 Fax: +86-755-8427 6832

Email & Skype: info@chipsmall.com Web: www.chipsmall.com

Address: A1208, Overseas Decoration Building, #122 Zhenhua RD., Futian, Shenzhen, China



Japan Aviation Electronics Industry, Ltd. Precision Manufacturing Equipment Division				Number	T 7 0 0 2 3 0 E			Page 1 / 9	
Spec:				Original issued: NOV. 17, 2000					
TITLE: Operation Manual for CT 1 5 0 - 4 C - I L Z				Rev.	Date	CN-No.	Prep	Chkd	Appd
						FILED			
ISSUED: Production Equipment & Tooling Dept.						DEC 0 4 2000			
Prepared	Checked	Approved	Approved			DOCUMENT CONTROL			
F.Kawano	<i>K. Koide</i>	<i>A. Iwasaki</i>	<i>T. Hashimoto</i>						



CAUTION

NOV. 2 4. 2000

- Be sure to read this manual before operation since all safety precautions are described in this manual.
- Properly keep this operation manual near the tool so that anyone can refer to them at anytime.
- Be sure to use the hand tool by following the instructions given in this operation manual. Otherwise, we will not be responsible for any accidents that may result.

This Hand crimping tool is used for crimping stripped wires to contacts. To obtain excellent crimped wires, be sure to read this manual carefully in order to fully understand this tool and operate it correctly.

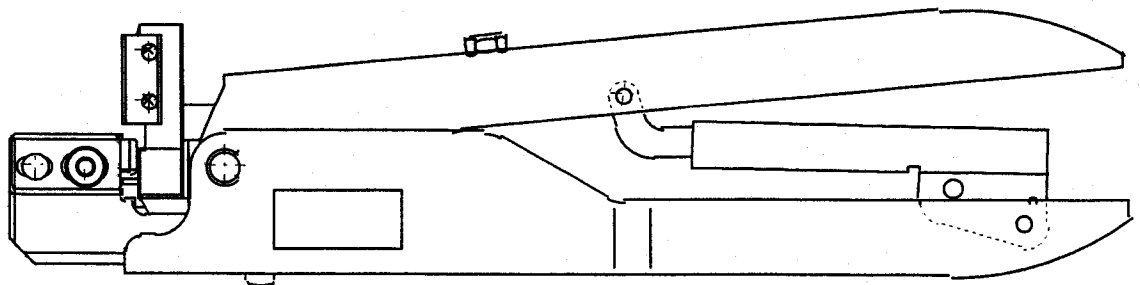

Japan Aviation Electronics Industry, Ltd. Precision Manufacturing Equipment Division	Number	T 7 0 0 2 3 0 E	Page 2/9
-----------------------------------------------------------------------------------------	--------	-----------------	-------------

Important Safeguards and Precautions

0317
 0005 1 0 0 0 0
 DOCUMENT CONTROL



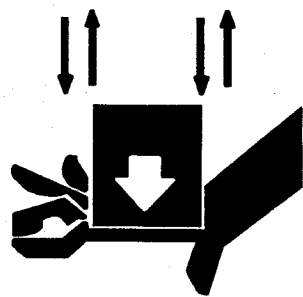

DANGER Pinch Points



The crimper moves OPEN/CLOSE.
NEVER put fingers into opening between the crimper and anvil.

About caution symbols: In this manual and on our products as well, the following caution symbols are used to show important information and warnings for correct use of our products. This is to avoid possible personal injury and property damage. Be sure to read and understand these special instructions before proceeding to the procedural details.

	DANGER	: A danger indicates an operation that results in serious personal injury or fatal wound if precautions are not followed.
	WARNING	: A warning indicates an operation that could cause serious personal injury or fatal wound if precautions are not followed.
	CAUTION	: A caution indicates an operation that could cause personal injury or equipment damage if precautions are not followed.

Examples of caution symbols:



An equilateral triangle \triangle serves the same as CAUTION (or DANGER and WARNING). It contains a specific warning information inside (the lightning flash with arrowhead symbol shown left means a risk of electric shock to persons).



A no entry mark \propto indicates an action that must be prohibited. Inside or near it is indicated a special instruction (the label shown left means prohibition of disassembly).



A black circle \bullet indicates a required action that must be proceeded without failure. It contains specific instructions inside (the label shown left means required disconnection of a plug from an outlet).

Japan Aviation Electronics Industry, Ltd. Precision Manufacturing Equipment Division	Number	T 7 0 0 2 3 0 E	Page 3/9
-----------------------------------------------------------------------------------------	--------	-----------------	-------------

1. Tool Name
CT150-4C-ILZ

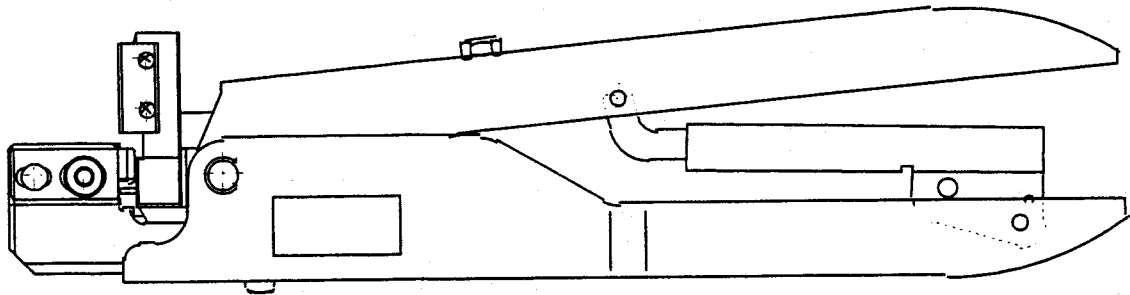

2. Notes on Handling this Tool

- ① Do not crimp other than specified contacts and wires.
- ② To keep this tool in good working condition for a long period of time, always keep it clean and handle it with care. Avoid dropping or handling it roughly.
- ③ The handle is adjusted so that the claw of ratchet is released when crimping is completed. Do not release the handle before crimping is completed.
- ④ It is not necessary to lubricate the crimper or anvil.
- ⑤ When using this tool, be sure to check that the contact crimp height meets the specified conditions.
- ⑥ This tool has two crimping sections, so select a proper one taking wire size into account.

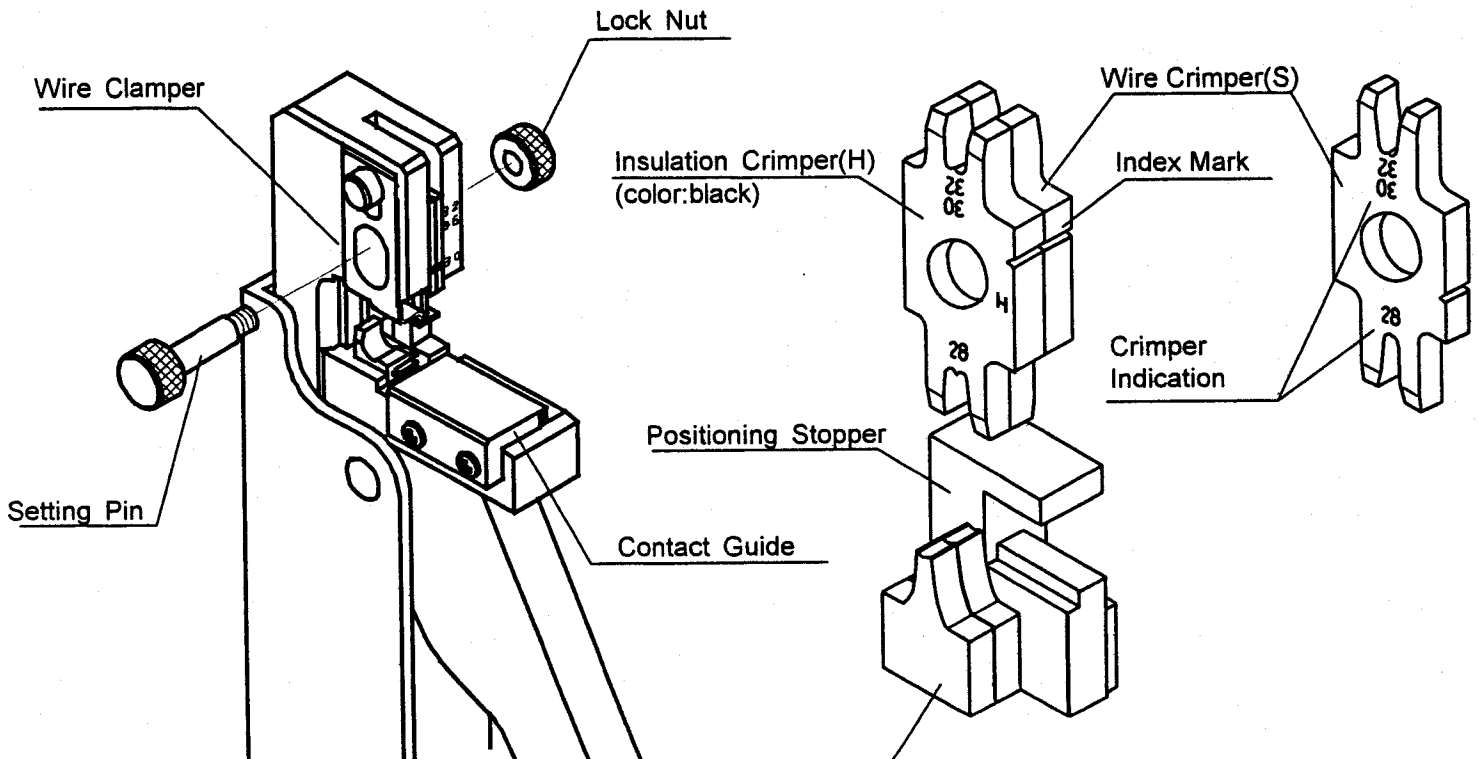

Japan Aviation Electronics Industry, Ltd. Precision Manufacturing Equipment Division	Number	T 7 0 0 2 3 0 E	Page 4 / 9
-----------------------------------------------------------------------------------------	--------	-----------------	---------------

4. Preoperation

4-1 Striping wire

Strip the specified length of insulation off each wire first. At this time, check that no cuts or flaws exist in the conductor and correct any disarrangement of the wire ends before starting to crimp.

4-2 Setting up Crimper

① Handles Release

Before inserting a contact into the tool, release the handle. The contact cannot be inserted if the handle is not released. To release the handle, grip it tightly until the ratchet is release.

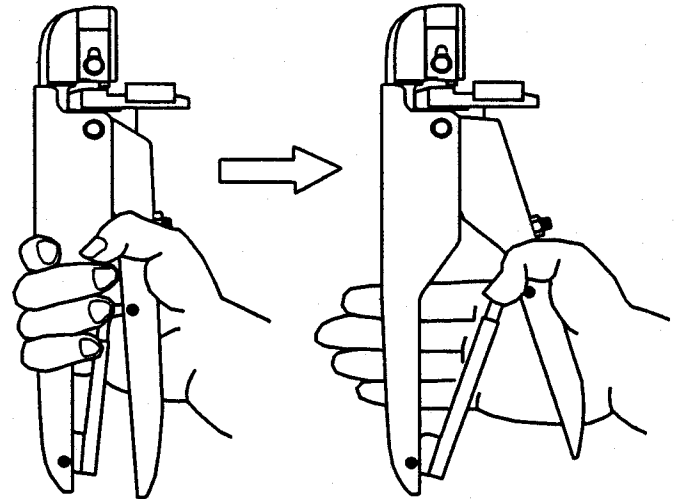

② Setting up Crimper

The wire crimper have two kinds of crimp cavities up and down sides.

Set it up according to the applicable wire.(see Table II)

Caution: Set up the wire crimper and the insulation crimper together with the wire size of the wire crimper indication out side.

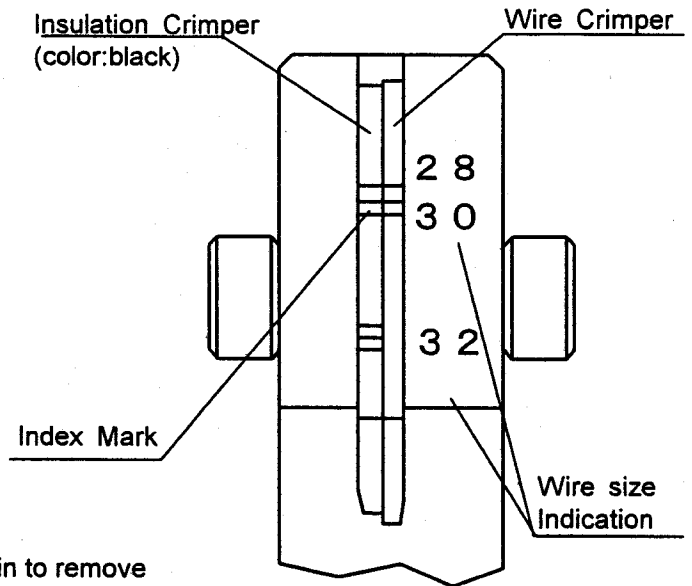

③ Check The Crimper Setting

Make sure to put the marks of the wire crimper and insulation crimper together.

④ Changing Wire Crimper

Unscrew the lock nut and take off the setting pin to remove the wire crimper and the insulation crimper.

Fix the appropriate side of the wire crimper in the tool body for the applicable wire before operating this tool.

Make sure the procedure of setting up the wire crimper and Insulation crimper or their tops.

Set up the Insulation crimper (color:black) in front side of this tool.

Set up the index mark(Insulation crimper" H "& wire size, Wire crimper" S "& wire size)is outside of this tool.

Insert the setting pin into the wire clammer and the tool body.

Then fasten the lock nut.

(Lock nut is able to fasten manually)

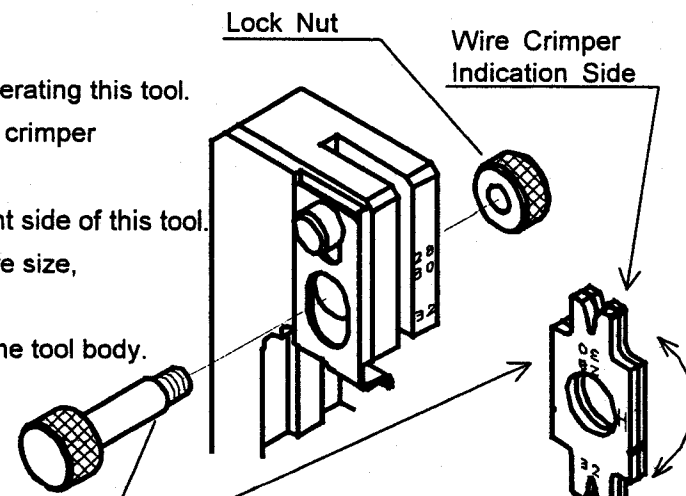

Japan Aviation Electronics Industry, Ltd. Precision Manufacturing Equipment Division	Number	T 7 0 0 2 3 0 E	Page 5/9
-----------------------------------------------------------------------------------------	--------	-----------------	-------------

4-3 Setting up contact

Install the insulation barrel of the reel contact which is cut about 100mm to 150mm into the contact guide until the contact side touches the positioning stopper.

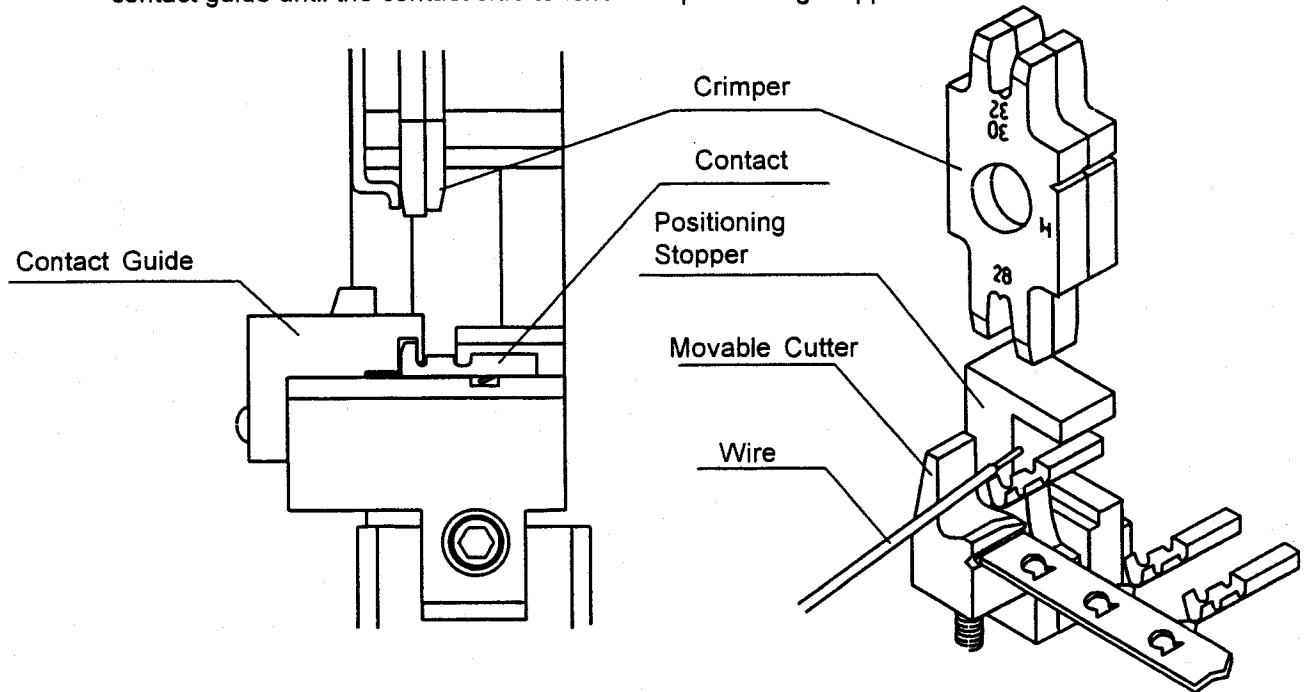

5. Operation

5-1 Preparation

Insert the conductor into the opening space between crimpers and anvil, and put the wire on the cutter. Then strike the tip of it slightly against the positioning stopper. It may happen that the tip of wire strikes too strongly against the positioning stopper and the crimping become rejected with bending it.

To maintain the situation, make sure to crimp with the wire being set on the anvil.

5-2 Crimping

Squeeze the handle gradually to the stroke end with holding the wire in place.

Then, crimping is done and the ratchet is released.



CAUTION

- The crimper moves OPEN/CLOSE.
- NEVER put fingers into opening between the crimper and anvil.



Japan Aviation Electronics Industry, Ltd. Precision Manufacturing Equipment Division	Number	T 7 0 0 2 3 0 E	Page 6/9
-----------------------------------------------------------------------------------------	--------	-----------------	-------------

5-3 Taking out the product

After crimping, the handle shall be let back to the opening position of itself, and take out the product that is crimped contact with wire.

Note: When you repeat crimping with same size cable, shift the contact by one pitch with hand, and operate in accordance with the above procedure (paragraph 4-1 thru 4-3).

6. Check of the crimped contact

This paragraph provides only rejected crimping peculiar to IL-Z Series contacts, an extra from IL-Z Series Connector Assembly Manual No. T87-5.

For product check other than crimping, see IL-Z Series Connector Assembly Manual No. T87-5.

Rejected Crimped Contact:

1) Declined insulation barrel, Bell-mouth

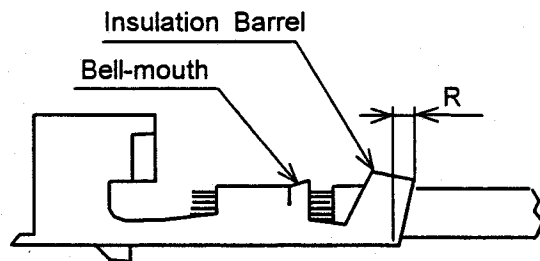

The dimension "R" of the declined insulation barrel is more than 0.5 mm.
 Bell-mouth(not crimped part) length is outside of range.
 (The range of Bell-mouth:0.05~1.15)

2) Longer insulation stripped length

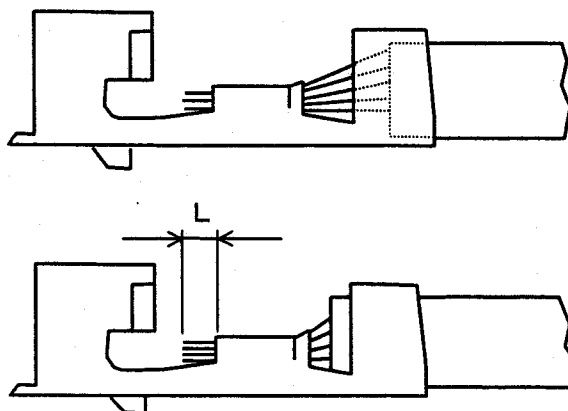

As the insulation stripped length is longer than the specified one, the insulation is inserted into half length of the insulation barrel only, or the dimension "L" is more than 0.6 mm.

3) Bend of contact

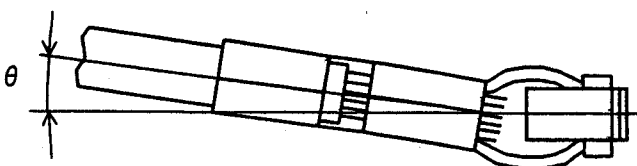

The bend "θ" of a contact is more than 3° against the upper part of the mating portion of the contact as a basis.

Japan Aviation Electronics Industry, Ltd. Precision Manufacturing Equipment Division	Number	T 7 0 0 2 3 0 E	Page 7/9
-----------------------------------------------------------------------------------------	--------	-----------------	-------------

5) Twisted contact

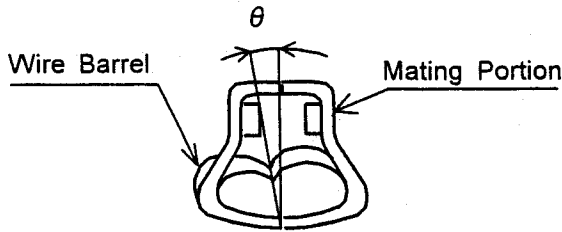

The degree, wire barrel is twisted against the mating portion, is more than 10° in all directions.

6) Bend-up and Bend-down, Carrier residuum

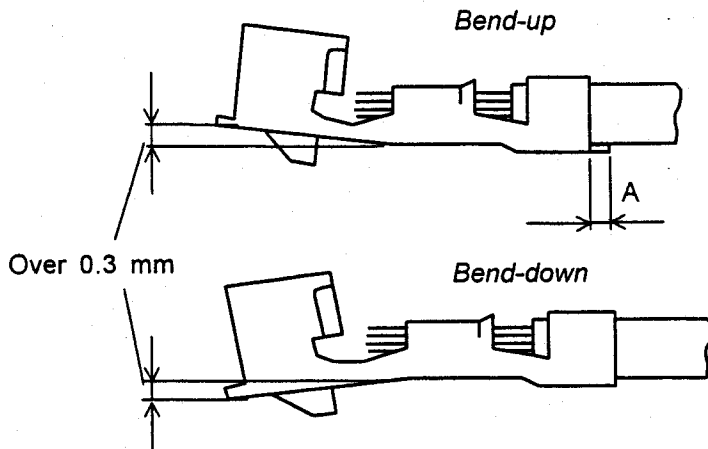

Based from the wire crimped portion, the bend-up amount or the bend-down amount of the mating tip is no less than 0.3 mm. The carrier cut residuum "A" is more than 0.1 mm.

iv) Deviation of insulation barrel

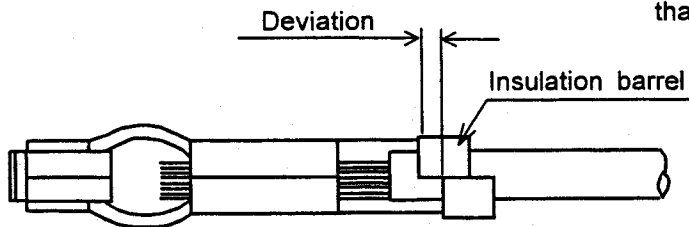

Deviation of insulation barrel is greater than half of barrel length.

7. Check of crimp height

When this tool is delivered, the crimp height has already been adjusted.

However, it may be due to the use for a long time that they can be out of adjustment.

Please make sure that crimp height of crimped contact is in the specified value shown in the next chapter.

Japan Aviation Electronics Industry, Ltd. Precision Manufacturing Equipment Division	Number	T 7 0 0 2 3 0 E	Page 8/9
-----------------------------------------------------------------------------------------	--------	-----------------	-------------

8.Applicable contact and cable and tool description

Table I (Dimension : mm)

Applicable Contact	Applicable Wire		
	Cable Size (AWG#)	Stranding	Outer Diameter of Insulation
IL-Z-C3-15000	28	Stranded 7 conductors	φ 0.5 ~ φ 1.0
	30		
IL-Z-C3-A-15000	32		

Table II (Dimension : mm)

Applicable Contact	Applicable Wire			Tool Indication		Standard for crimp height	
	Wire Size (AWG#)	Outside Diameter of insulation	Stripped Length	Wire Crimper	Insulation Crimper	Conductor ±0.02(mm)	Insulation ±0.1(mm)
IL-Z-C3-15000 IL-Z-C3-A-15000	28	φ 0.7 ~ φ 1.0	1.5 ~ 1.9	28	28	0.58	1.30
		φ 0.5 ~ φ 0.8			30-32		1.10
	30~32	φ 0.7 ~ φ 1.0		30	28	0.54	1.30
		φ 0.5 ~ φ 0.8		32	30-32		1.10

Note 1. Select wire and insulation crimper according to applicable cable size.

Note 2. Applicable wire is stranded 7 conductors. Using not specified wire, please ask us whether the wire is usable or not.

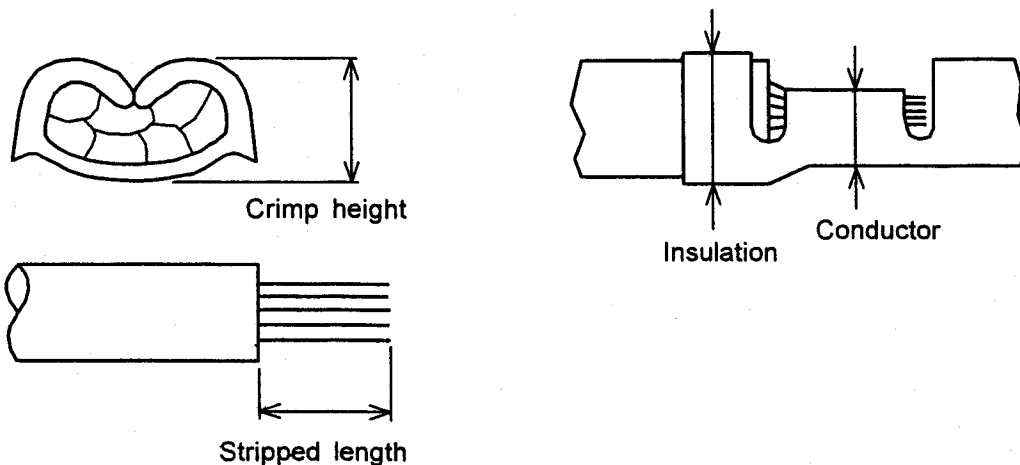

Japan Aviation Electronics Industry, Ltd. Precision Manufacturing Equipment Division	Number	T 7 0 0 2 3 0 E	Page 9/9
-----------------------------------------------------------------------------------------	--------	-----------------	-------------

9. Crimp Strength

The tensile strength when the conductor part of a wire is crimped is the crimping strength. When crimping is done accurately with this tool, the crimping strength meets the specifications shown in the table below:

Wire Size (AWG)	#32	#30	#28
Crimping Strength	5.8N	9.8N	13.7N