



Chipsmall Limited consists of a professional team with an average of over 10 year of expertise in the distribution of electronic components. Based in Hongkong, we have already established firm and mutual-benefit business relationships with customers from,Europe,America and south Asia,supplying obsolete and hard-to-find components to meet their specific needs.

With the principle of “Quality Parts,Customers Priority,Honest Operation,and Considerate Service”,our business mainly focus on the distribution of electronic components. Line cards we deal with include Microchip,ALPS,ROHM,Xilinx,Pulse,ON,Everlight and Freescale. Main products comprise IC,Modules,Potentiometer,IC Socket,Relay,Connector.Our parts cover such applications as commercial,industrial, and automotives areas.

We are looking forward to setting up business relationship with you and hope to provide you with the best service and solution. Let us make a better world for our industry!



Contact us

Tel: +86-755-8981 8866 Fax: +86-755-8427 6832

Email & Skype: info@chipsmall.com Web: www.chipsmall.com

Address: A1208, Overseas Decoration Building, #122 Zhenhua RD., Futian, Shenzhen, China



THIS DRAWING AND THE INFORMATION SET FORTH HERE-ON ARE THE PROPERTY OF TYCO ELECTRONICS CORPORATION, AND ARE TO BE HELD IN TRUST AND CONFIDENCE. PUBLICATION, DUPLICATION, DISCLOSURE, OR USE FOR ANY PURPOSE NOT EXPRESSLY AUTHORIZED IN WRITING BY TYCO ELECTRONICS CORPORATION IS PROHIBITED.

REVISIONS			
LTR	DESCRIPTION	DATE	APPROVED
1	PRE PRODUCTION RELEASE ECN T-4500	11/22/83	J.B.
A	PER ECO-09-025648	Nov/16/09	M.HIGGY

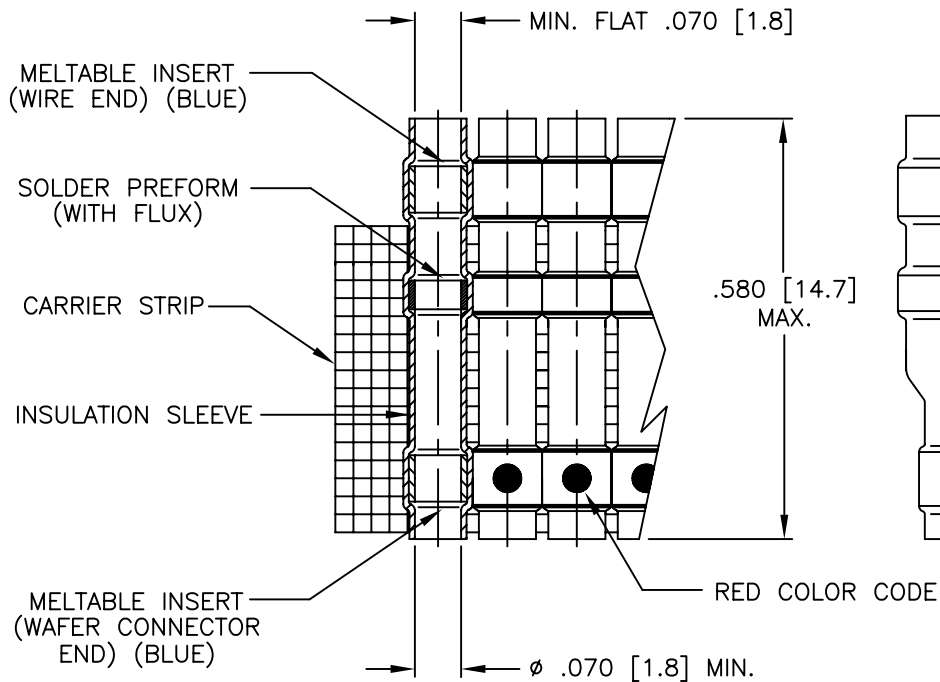
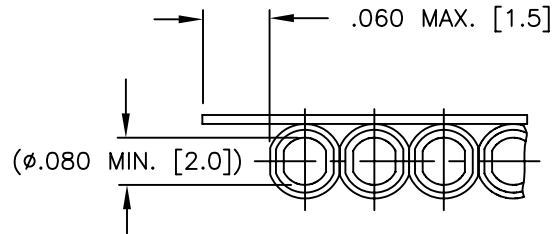

NOTES:

- MATERIALS:
 - INSULATION SLEEVE: HEAT SHRINKABLE, RADIATION CROSSLINKED MODIFIED POLYVINYLIDENE FLUORIDE, TRANSPARENT BLUE.
 - SOLDER PREFORM: SOLDER TYPE: Sn96
FLUX TYPE: RA
PER ANSI-J-STD-006.
 - MELTABLE INSERTS: LOW OUTGASSING IMMERSION RESISTANT THERMOPLASTIC.
 - CARRIER STRIP: ADHESIVE COATED HIGH TEMPERATURE TAPE.
- A CTA-0067 ASSEMBLY CONSISTS OF 20 EACH CTA-0065 SOLDERSLLEEVE WIRE TERMINATORS.
- THESE SLEEVES ARE DESIGNED TO ATTACH 20 THROUGH 26 GAGE TIN, NICKEL OR SILVER PLATED CONDUCTORS TO TERMINALS OF A TE MTC100 SERIES WAFER.

© 2009 Tyco Electronics Corporation. All rights reserved. CUSTOMER DRAWING

UNLESS OTHERWISE SPECIFIED DIMENSIONS ARE IN INCHES. METRIC DIMENSIONS ARE IN BRACKETS. DECIMALS .XXX ± .XX ± N/A mm ANGLES .X ±	DRAWN	Zsofia O.	Nov/9/09		Raychem Interconnect 300 Constitution Drive Menlo Park, CA 94025 U.S.A.	
	CHECKED				TITLE	
	APPROVED	M. HIGGY	Nov/9/09	SOLDERPACK [®] TERMINATOR ASSEMBLY WITH OVAL ENTRY TEMPERATURE RATING 150 CELSIUS DEGREE, Sn96 MTC100 SERIES		
	APPROVED			CAD NAME CTA-0067		
WEIGHT:	THIRD ANGLE PROJECTION			SIZE B	CAGE CODE: 06090	DWG. NO. CTA-0067
				SCALE: NONE	REV A	SHEET 1 OF 1

If this document is printed it becomes uncontrolled. Check for the latest revision

® Trademark of Tyco Electronics Corporation.