



Chipsmall Limited consists of a professional team with an average of over 10 year of expertise in the distribution of electronic components. Based in Hongkong, we have already established firm and mutual-benefit business relationships with customers from,Europe,America and south Asia,supplying obsolete and hard-to-find components to meet their specific needs.

With the principle of “Quality Parts,Customers Priority,Honest Operation,and Considerate Service”,our business mainly focus on the distribution of electronic components. Line cards we deal with include Microchip,ALPS,ROHM,Xilinx,Pulse,ON,Everlight and Freescale. Main products comprise IC,Modules,Potentiometer,IC Socket,Relay,Connector.Our parts cover such applications as commercial,industrial, and automotives areas.

We are looking forward to setting up business relationship with you and hope to provide you with the best service and solution. Let us make a better world for our industry!



Contact us

Tel: +86-755-8981 8866 Fax: +86-755-8427 6832

Email & Skype: info@chipsmall.com Web: www.chipsmall.com

Address: A1208, Overseas Decoration Building, #122 Zhenhua RD., Futian, Shenzhen, China





CTH Series

Capacitive Touch Sensor Display

15.0 x 15.0 x 11.0 mm

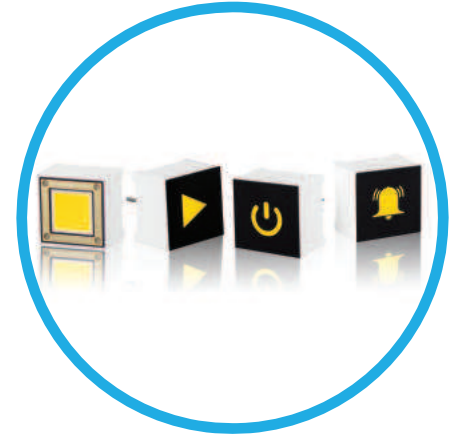

CTHS15CIC07 - Yellow Capacitive Touch Sensor Through Hole with a Display Size of 0.59 x 0.59 inches (15 x 15 mm) square



Applications

- Mobile communication devices
- Electronic devices
- Point of sale Terminals
- Gaming
- Industrial control displays
- Touch Screen Monitors
- Portable Instruments
- Media Players
- Medical devices
- Appliances and consumer equipments

Key Features

- Integrated touch sensing and display technology
- Enables the device interface to be more user friendly and intuitive
- Mounting type: through hole (industry standard pitch 0.100")
- Available in one standard size: 15.0mm x 15.00mm x 11.00mm
- Available in 5 colors: super red, white, pure green, blue or yellow
- Touch sensor: integrated circuit (IC)
- Uniform illumination and high optical clarity due to LED technology
- Robust design due to no mechanical moving parts
- Simplifies devices design and manufacturability
- Optional overlay (icons): on/off, arrow, alarm
- Custom overlay icon can be manufactured upon request - contact VCC
- Compliant with RoHS and REACH requirements
- Capacitive sensor still functional when hands are wet
- Capacitive sensor still functional when hands are covered with certain types of gloves

Ordering Data

The CTH Series (Cap Touch) is available in a range of standard features and options. To specify your Cap Touch Display, simply choose one option from each column.

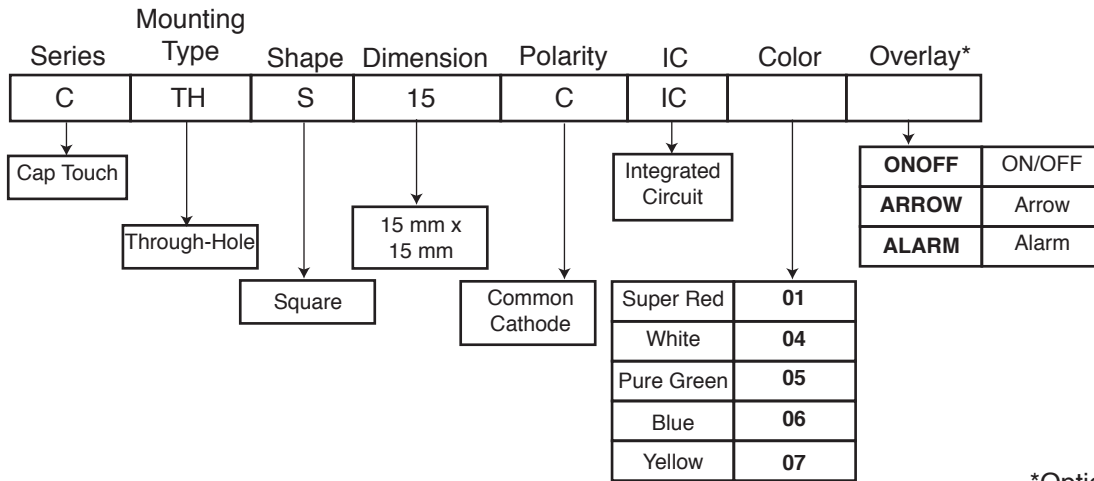



*Optional

Overlay

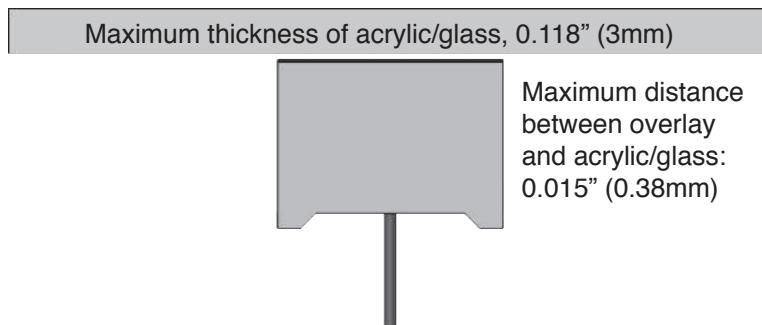
- Different LED colors can indicate the mode in which an electronic device is operating, depending on the icon associated with it.
- Optional graphic overlay made with polished LEXAN™ Polycarbonate 8010 Film 0.007" (0.175 mm) thick has reverse printed translucent white icon, in order to still see it even when the back lighting is off.
- Lexan 8010 is a transparent polycarbonate film and offers hardness, chemical and abrasion resistance, stiffness, and high temperature capability.
- Adhesive: 3 M waterclear
- Three standard icons are available: alarm, arrow and on-off. Custom icons are also available upon request.
- Capacitive Touch Display can also be mounted behind clear glass or plastic layer such as polycarbonate or acrylic, as shown in the picture below.
- Suggested overlay size: 0.590" x 0.590"



- Suggested icon size: 0.34" x 0.34" (max.)

	Overlay On/Off
	Overlay Arrow
	Overlay Alarm

Package Dimensions

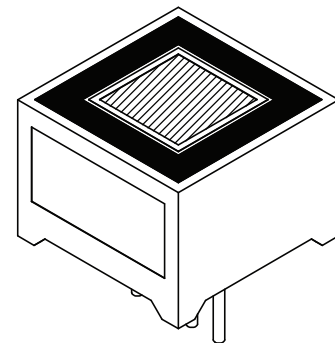
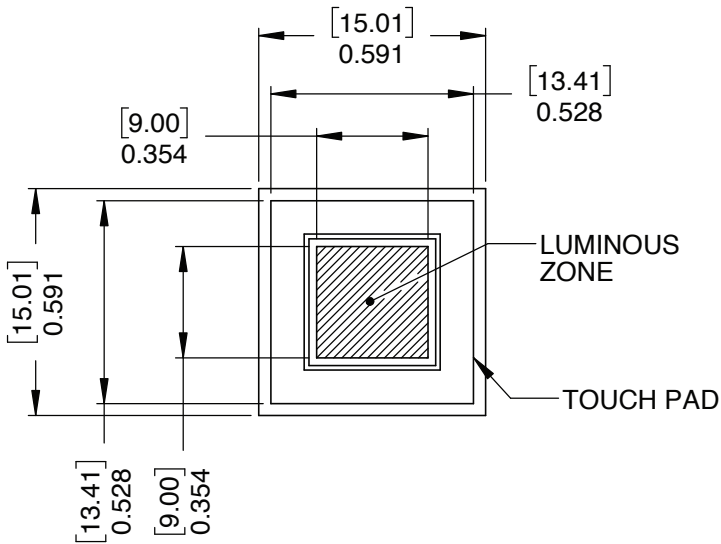
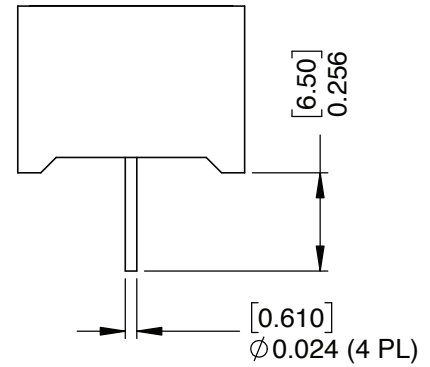
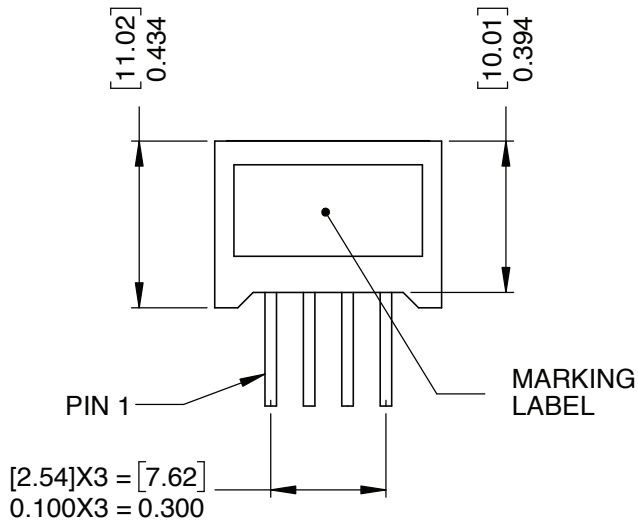

MARKING LABEL INFO

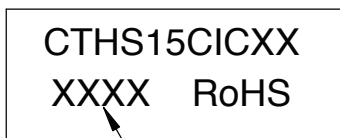

DATE CODE

Dimensions in [mm] inches
General tolerances unless otherwise specified:

	inches	mm
.X	$\pm .020$	$\pm .508$
.XX	$\pm .010$	$\pm .254$
.XXX	$\pm .005$	$\pm .127$

Internal Circuit Diagram

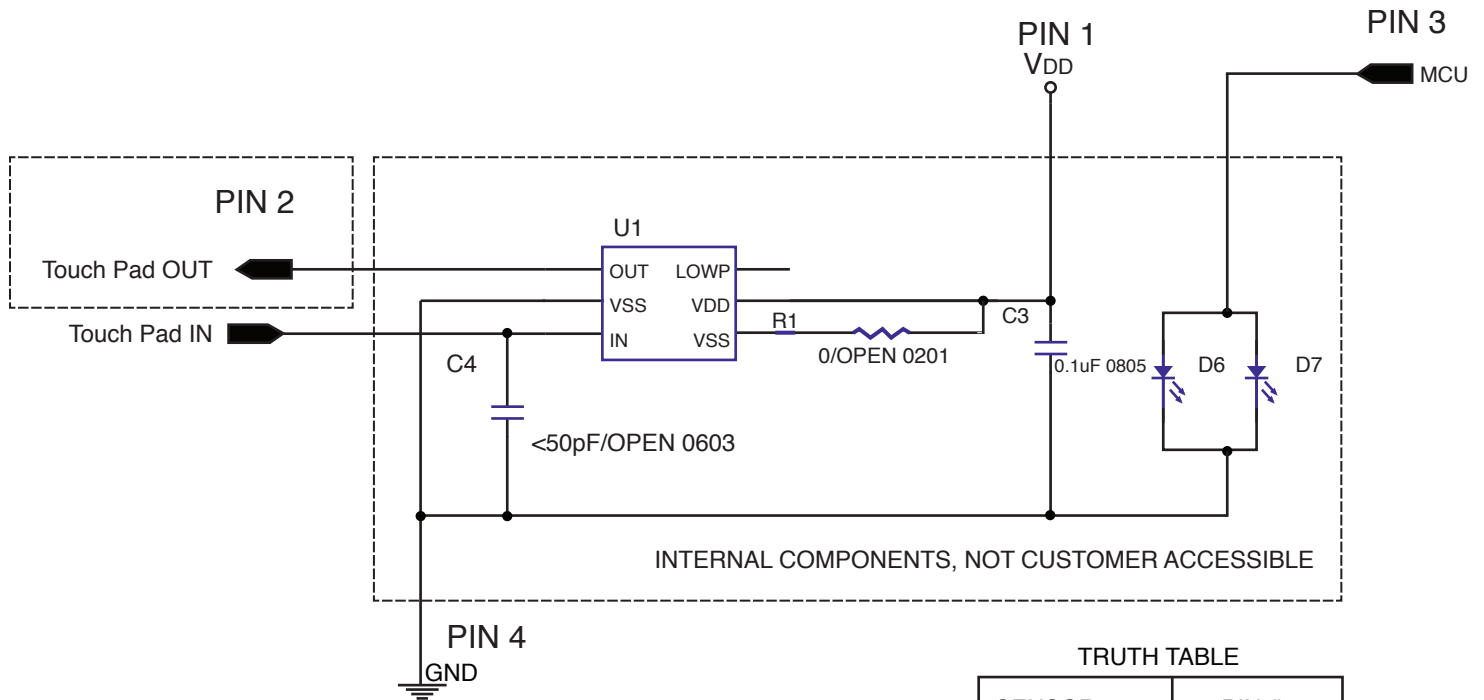

TRUTH TABLE

SENSOR	PIN # 2
NOT TOUCHED	LOW
TOUCHED	HIGH

Internal IC Electrical Characteristics

(TA = 25°C, unless otherwise specified)

Symbol	Parameter	Condition	Min.	Typ.	Max.	Units.
VDD	Supply Voltage (Pin#1)		2.0		5.5	V
VIH	High Level Input Voltage	@ VDD = 5V	0.7VDD		VDD	V
VIL	Low Level Input Voltage	@ VDD = 5V			0.3VDD	V
IDD1	Operating Current	@ VDD = 5V , no load		16		μA
		@ VDD = 3V , no load		3.5		
IDD2	Operating Current (SLRT=VDD)	@ VDD = 5V , no load		10.5		μA
		@ VDD = 3V , no load		2.5		
IOL	Low Level Output Current (Pin#2)	@ VDD = 3V, VOL = 1V		30		mA
IOH	High Level Output Current (Pin#2)	@ VDD = 3V, VOL = 2V		8		mA

Product Specifications

ABSOLUTE MAXIMUM RATING FOR LED

(Ta=25°C)

Parameter	Symbol	Rating	Unit
		Yellow	
Power Dissipation Per LED	PAD	70	mW
Derating Liner from 25°C per LED	-	0.33	mA/°C
Continuous Forward Current Per LED	IAF	25	mA
Peak Current Per LED (duty cycle 1/10,1KHz)	IPF	90	mA
Reverse Voltage Per LED	VR	5	V
Operating Temp.	Topr	-35 ~ +85	°C
Storage Temp.	Tstg	-35 ~ +85	°C

ELECTRO-OPTICAL CHARACTERISTICS

(Ta=25°C)

Parameter	Symbol	Min.	Typ.	Max.	Unit	Condition
Luminous Intensity	Iv	113	220	--	mcd	IF = 20 mA
Forward Voltage	VF	--	2.1	2.8	V	IF = 20 mA
Peak Emission Wavelength	λP	--	592	--	nm	IF = 20 mA
Dominant Wavelength	λD	--	590	--	nm	IF = 20 mA
Spectrum Radiation Bandwidth	Δλ	--	20	--	nm	IF = 20 mA
Luminous Intensity Matching Ratio	Iv-M	--	-	2 : 1	--	IF = 10 mA
Reverse Current	IR		-	100	μA	VR = 5V

Product Specifications

ELECTRICAL/OPTICAL CHARACTERISTICS CURVES

(Ta=25°C)

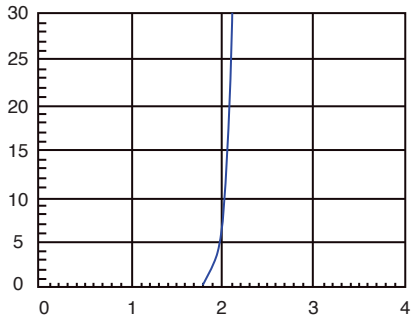

Forward Voltage (V)
Forward Current vs. Forward Voltage

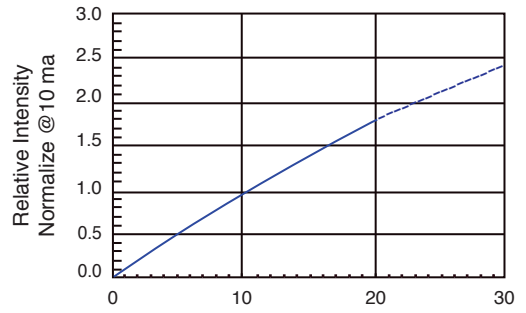

Forward Voltage (mA)
Relative Intensity vs. Forward Current

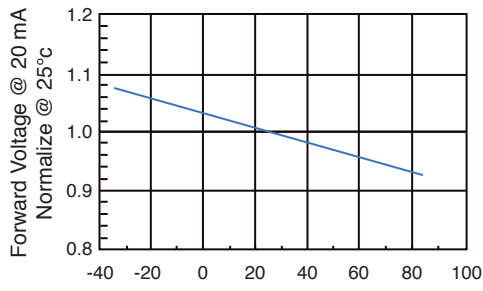

Ambient Temperature (°C)
Forward Voltage vs. Temperature

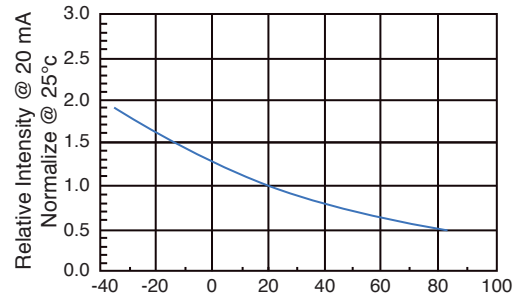

Ambient Temperature (°C)
Relative Intensity vs. Temperature

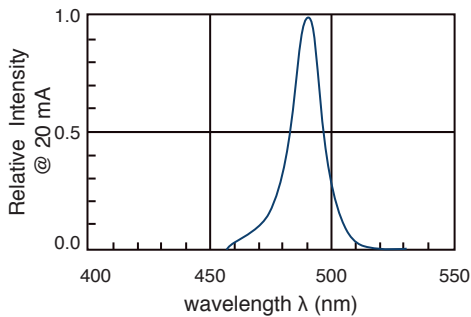

wavelength λ (nm)
Relative Intensity vs. Wavelength

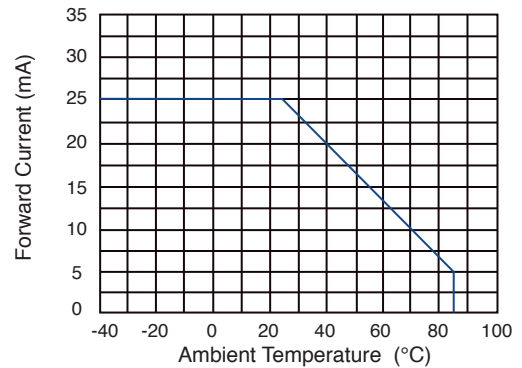

Ambient Temperature (°C)
Forward Current vs. Temperature

Product Specifications

SOLDERING CONDITIONS

1. Wave Soldering Profile

Distance: 1.6mm min (From Seating Plane)

Item	Condition		Note
Preheat	Temperature T1	80 – 120 °C	PWB Temperature (Soldering Side Surface)
	Time t1	60 – 180sec	
Solder Dip	Temperature T2	230 – 260°C	Bath Temperature
	Time t2	2 – 4 sec	Solder Tank Passage Time

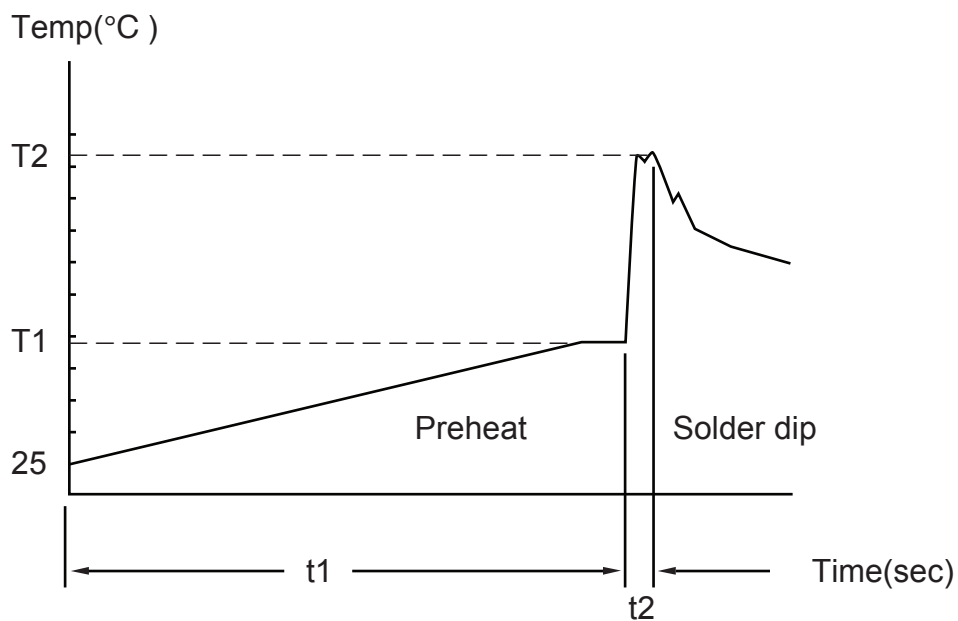

2. Hand Soldering (Iron Condition)

Soldering Iron: 30W Max

Temperature 350°C Max

Soldering Time: 3 Seconds Max (One Time)

Distance: 1.6mm min (From Seating Plane)

Application Circuit

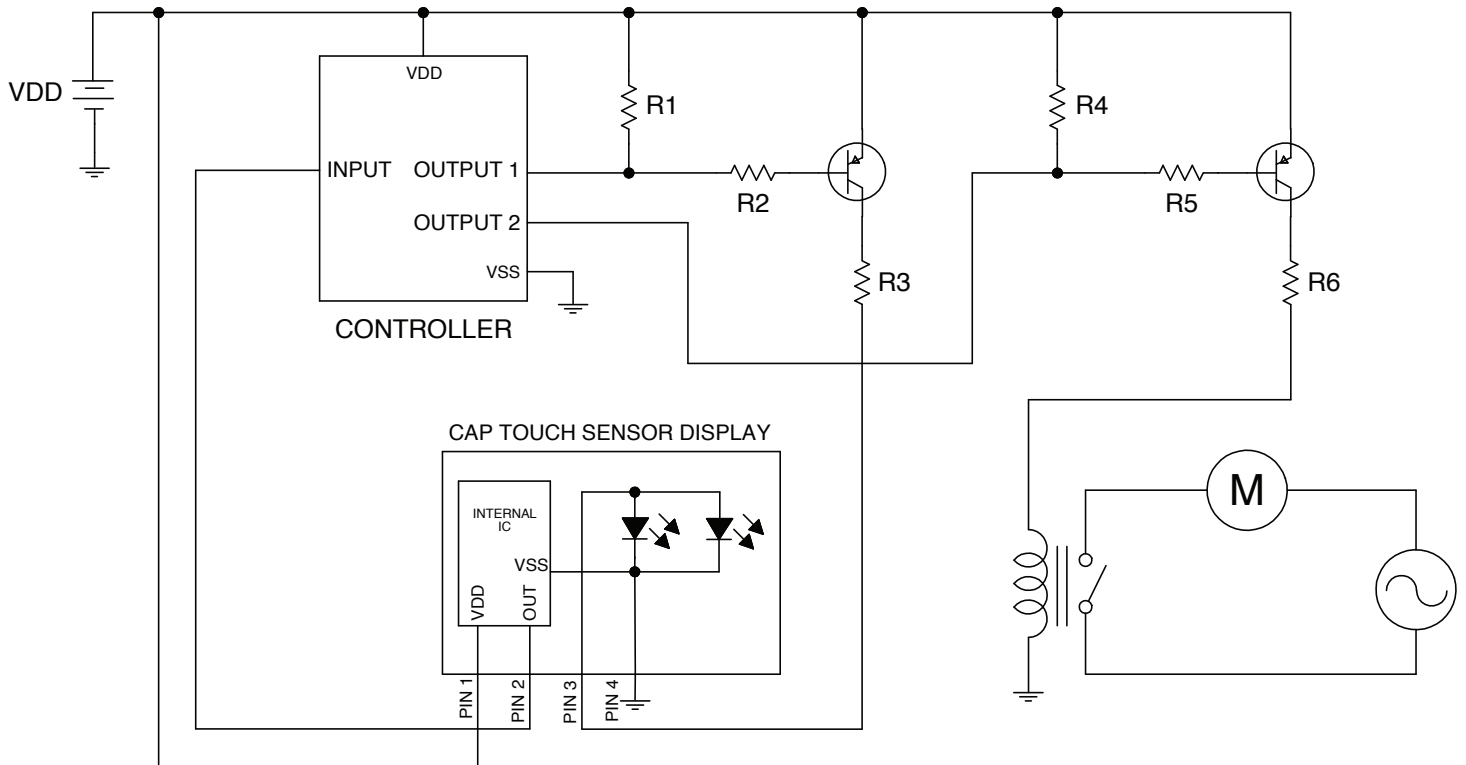

Compliances and Approvals

