



Chipsmall Limited consists of a professional team with an average of over 10 year of expertise in the distribution of electronic components. Based in Hongkong, we have already established firm and mutual-benefit business relationships with customers from,Europe,America and south Asia,supplying obsolete and hard-to-find components to meet their specific needs.

With the principle of “Quality Parts,Customers Priority,Honest Operation,and Considerate Service”,our business mainly focus on the distribution of electronic components. Line cards we deal with include Microchip,ALPS,ROHM,Xilinx,Pulse,ON,Everlight and Freescale. Main products comprise IC,Modules,Potentiometer,IC Socket,Relay,Connector.Our parts cover such applications as commercial,industrial, and automotives areas.

We are looking forward to setting up business relationship with you and hope to provide you with the best service and solution. Let us make a better world for our industry!



## Contact us

Tel: +86-755-8981 8866 Fax: +86-755-8427 6832

Email & Skype: info@chipsmall.com Web: www.chipsmall.com

Address: A1208, Overseas Decoration Building, #122 Zhenhua RD., Futian, Shenzhen, China



4

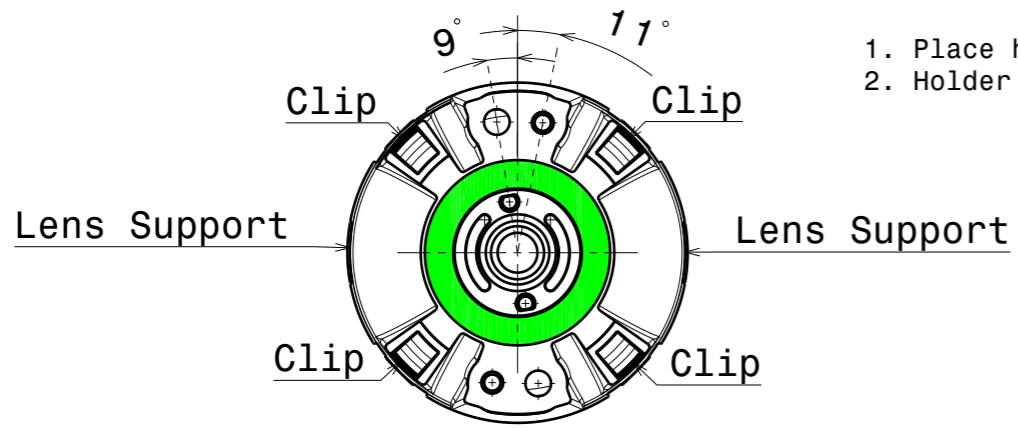

1. Place holder on PCB using the holder location pins as guide elements.  
2. Holder is fixed in place with the tape.

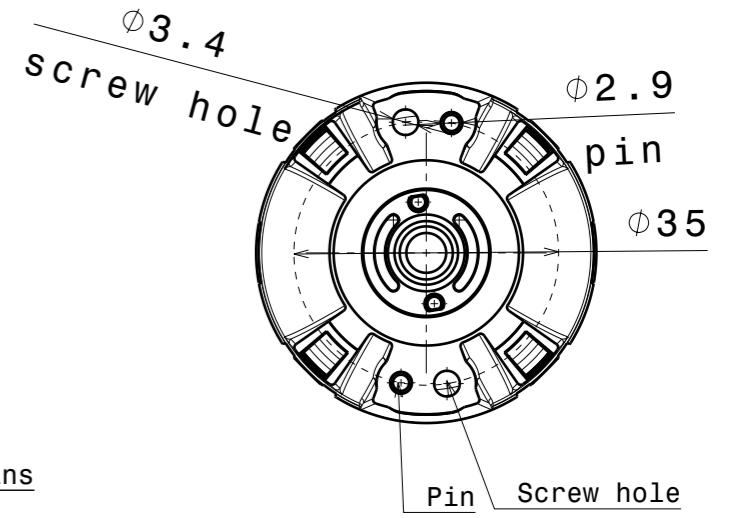

3

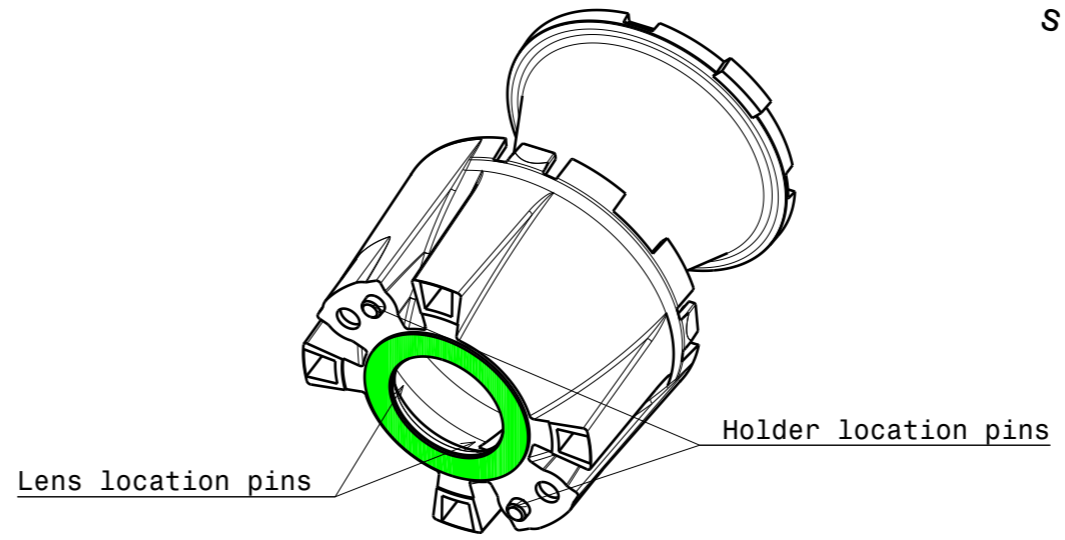
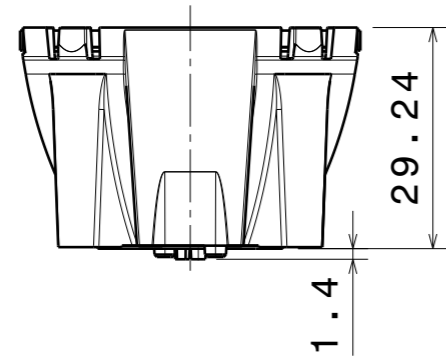

3. Place lens support features into relative holes in the holder, please note that the location pins on the lens goes through the PCB.  
4. Press optic until all 4 clips are locked.

2

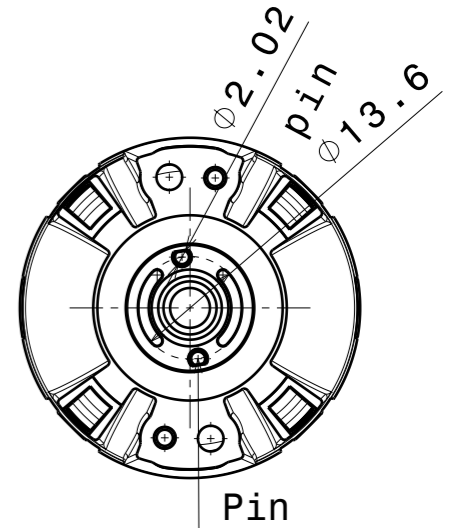
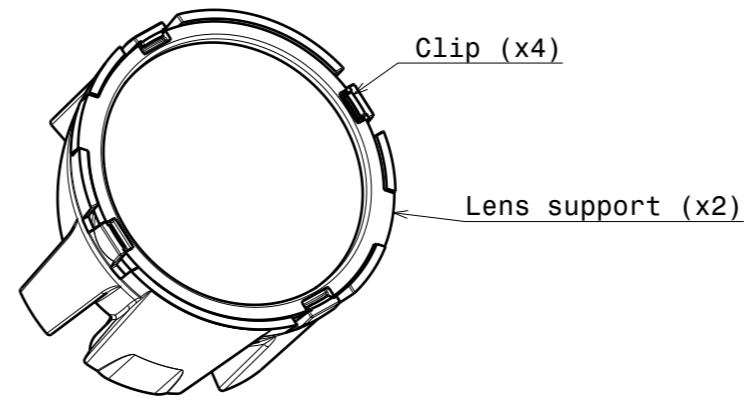
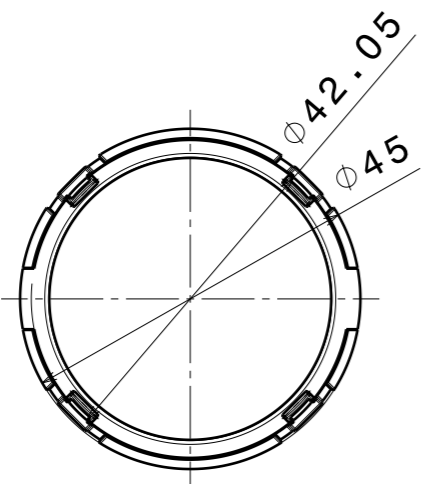

1

Notes:  
█ 1. PCB level  
█ 2. Ensure exact LED fitting from [www.ledil.com](http://www.ledil.com) and/or the 3d mechanical model to count in LED structural variation such as LED dome shape and LED base size.

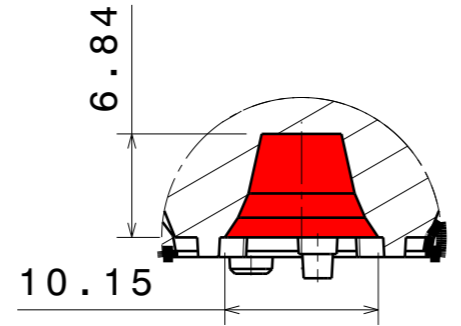

INDEX	PART NO	DESCRIPTION	MATERIAL	COLOUR
1	CX15819	GABRIELLA-45-W	Lens PMMA Holder PC Tape PU	

Tolerances if not otherwise shown  
 According to DIN ISO 2768-1  
 Linear measures:  
 Up to 30mm class M, otherwise class C.  
 According to DIN ISO 2768-2  
 Form and position: class L

**LEDiL** Ledil Oy  
 Salorankatu 10  
 FIN 24240 SALO  
 Finland

THIRD ANGLE PROJECTION:

DRAWING TITLE  
**CX15819\_GABRIELLA-45-W**

This drawing is the property of LEDiL Oy. It may not be reproduced, copied or communicated without a written agreement with LEDiL Oy.

SIZE	PART NUMBER		
<b>A3</b>	<b>CX15819</b>		

SCALE	1:1	WEIGHT	-	SHEET	1/1
-------	-----	--------	---	-------	-----