



Chipsmall Limited consists of a professional team with an average of over 10 year of expertise in the distribution of electronic components. Based in Hongkong, we have already established firm and mutual-benefit business relationships with customers from,Europe,America and south Asia,supplying obsolete and hard-to-find components to meet their specific needs.

With the principle of “Quality Parts,Customers Priority,Honest Operation,and Considerate Service”,our business mainly focus on the distribution of electronic components. Line cards we deal with include Microchip,ALPS,ROHM,Xilinx,Pulse,ON,Everlight and Freescale. Main products comprise IC,Modules,Potentiometer,IC Socket,Relay,Connector.Our parts cover such applications as commercial,industrial, and automotives areas.

We are looking forward to setting up business relationship with you and hope to provide you with the best service and solution. Let us make a better world for our industry!



## Contact us

Tel: +86-755-8981 8866 Fax: +86-755-8427 6832

Email & Skype: info@chipsmall.com Web: www.chipsmall.com

Address: A1208, Overseas Decoration Building, #122 Zhenhua RD., Futian, Shenzhen, China



# PRODUCT DATASHEET

## PART NUMBER: CX2232NL

- 1:1 RF Transformer
- 800-1900 MHz
- Suitable for MoCA Applications
- Surface Mount, FR4 Substrate
- RoHS Compliant

**Electrical Specifications @ 25°C (Operating Temperature -40°C to +85°C)**

**INSERTION LOSS :**

800-1900 MHz	900-1400 MHz						
3.0 dB Max	1.0 dB Max						

Note: Insertion Loss is referenced to Mid-Band Loss

**RETURN LOSS :**

800 MHz	1200 MHz	1600 MHz	1900 MHz				
18.0 dB Min	15.0 dB Min	14.0 dB Min	13.0 dB Min				

## Mechanical Specifications

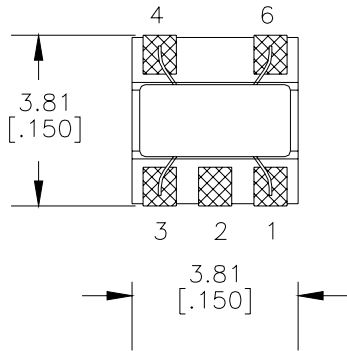

TOP VIEW

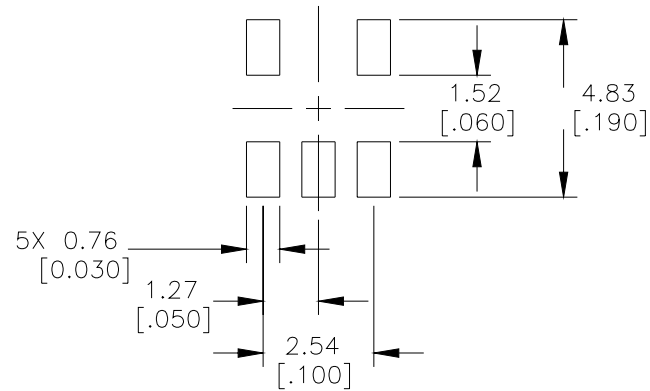

SUGGESTED LAND PATTERN  
TOP VIEW

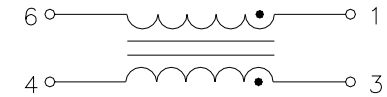

SCHEMATIC

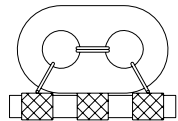

SIDE VIEW

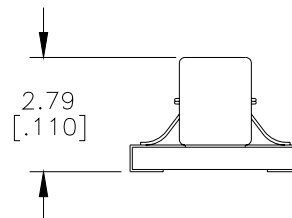

FRONT VIEW

DIMENSIONS	MM	[INCH]
TOLERANCES	.XX +/- .25	.XX +/- .01
	.XXX +/- .12	.XXX +/- .005