



Chipsmall Limited consists of a professional team with an average of over 10 year of expertise in the distribution of electronic components. Based in Hongkong, we have already established firm and mutual-benefit business relationships with customers from,Europe,America and south Asia,supplying obsolete and hard-to-find components to meet their specific needs.

With the principle of “Quality Parts,Customers Priority,Honest Operation,and Considerate Service”,our business mainly focus on the distribution of electronic components. Line cards we deal with include Microchip,ALPS,ROHM,Xilinx,Pulse,ON,Everlight and Freescale. Main products comprise IC,Modules,Potentiometer,IC Socket,Relay,Connector.Our parts cover such applications as commercial,industrial, and automotives areas.

We are looking forward to setting up business relationship with you and hope to provide you with the best service and solution. Let us make a better world for our industry!



Contact us

Tel: +86-755-8981 8866 Fax: +86-755-8427 6832

Email & Skype: info@chipsmall.com Web: www.chipsmall.com

Address: A1208, Overseas Decoration Building, #122 Zhenhua RD., Futian, Shenzhen, China



MESSRS :

Product Drawing

CUSTOMER'S PRODUCT NAME :

TDK PRODUCT NAME: DC/AC INVERTER UNIT CXA- L0605C-VxL

TENTATIVE

***Notice**

Product Drawing is not contract. This is only technical data.

This technical data may change internal description without any notice.

When you design final product please request us specification through our sales or distributors.

After you receive the specification, the contract is effective on signature of the specification.



TDK-Lambda Corporation

PREPARED BY	APPROVED BY	AUTHORIZED BY
<i>April.12.2010 K.Negoro</i>	<i>April.12.2010 K.Yamaishi</i>	<i>April.12.2010 H.Masuoka</i>

DWG.No.

CTR-3818-X

Precautionary Notes Regarding the Use of This Inverter

When using this product, give due consideration to the precautionary notes described below and ensure a safe design. Inappropriate use may result in electric shock, injury or fire.

⚠ Warning



- This product is subject to high voltage. Do not touch it while the power is on. Failing to do so may result in electric shock.

⚠ Caution

- This product is designed for lighting Cold Cathode Fluorescent Lamps. Do not use it with any other load.
- Store this product under the conditions defined in the specification document.
- Do not store this product in an environment where dust, dirt or corrosive gas (salt, acid, base, etc.) is present.
- This product is subject to high voltage. If there is a possibility that the user may touch the product, provide a proper warning indication in order to draw the user's attention.
- This product is designed for use with general electronic equipment. If it is to be used with medical equipment that directly affects human life or for the control of transportation equipment to which passengers entrust their lives, provide thorough fail-safe measures.
- Consult us before using if this product is to be installed in a habitual vibration environment (vehicle, etc.).
- Avoid using this product under high temperatures or high humidity or in an environment in which dust, dirt or any corrosive gas (salt, acid, base, etc.) is present. Also, be careful not to allow the formation of dew condensation. It may result in damage or electric shock.
- If the product does not have a built-in protective circuit (circuit breaker, fuse, etc.), it is recommended that a fuse be used at the input stage to prevent the generation of smoke or fire in the event of a malfunction. Even when the product has a built-in protective circuit (circuit breaker, fuse, etc.), the circuit may not function properly due to inappropriate operating conditions or power-supply capacity. It is recommended that an appropriate protective circuit (circuit breaker, fuse, etc.) be provided separately from the built-in circuit.
- Use the product only within the specified input voltage, output power, output voltage and operating temperature ranges. Exceeding these values may result in damage, etc.
- Provide a measure for the prevention of surge voltage due to lightning, etc. Abnormal voltage may result in damage, etc.
- To prevent problems from occurring as a result of a short circuit in the high voltage section, be sure to take appropriate measures to prevent the entry of foreign substances into the inverter after it is installed.
- This product is not designed to provide resistance to radiation.
- In order to protect the inverter from vibration and shock, be sure to use all the mounting holes when installing the inverter.
- Ripples could be superimposed on the voltage and the current in the input source connected to the inverter, depending on the impedance in the input source, wiring, etc. When you select an input source, please check waveforms, etc on the final set.
- Please use all the mounting holes, because to defend the converter from vibration and impact.

Handling Precautions

- This product uses thin wires. Observe the following precautions and handle it with care so as not to cause wire breakage. Broken wire may result in damage, etc.
 - ❖ Do not stack multiple products on top of one another.
 - ❖ Do not allow the product to come in contact with tools, etc.
- Do not apply excessive stress during installation. It may cause chipping and cracking, resulting in damage, etc.
- Provide clearance between the high-voltage section of this product and the frame body on which the product is installed and also the conductor section as on page 2, [1] "Outline".
- Do not use the product after it has been dropped because there is the possibility that components have been damaged.

	No.	MATERIALS NAME	QU	MATERIAL	REMARK	
	PRODUCT NAME or MODEL, TITLE					
	DC-AC INVERTER UNIT CXA-L0605C-VxL					
TDK-Lambda	NAME OF DRAWING			DRAWING No.	PAGE	
	Product Drawing			CTR-3818-X	1	

1. Part Name

The part name is CXA-L0605C-VxL

2. Contents

Item	Attached view	Page
1.Appearance,Structure and Dimensions		
Outline	refer to [1]	3
Pin configuration	refer to [1]	4
2.Characteristics		
Absolute Maximum Ratings	refer to [2]	5
3.Electrical Characteristics	refer to [3]	5
4.Test circuit	refer to [4]	6
5.Reliability Test	refer to [5]	7
6.Packing and Marking	refer to [6]	8
7.Others		
Test Cond Std Warranty Others	refer to [7]	8

No.	MATERIALS NAME	QU	MATERIAL	REMARK
PRODUCT NAME or MODEL,TITLE				
DC-AC INVERTER UNIT CXA-L0605C-VxL				
NAME OF DRAWING			DRAWING No.	PAGE
Product Drawing			CTR-3818-X	2

TDK-Lambda

●Features●

- This inverter is one lamp. It has Dimming function(Analog Dimming System) and Remote function.
 - The high-voltage area (terminals and patterns) is coated with silicone so as to avoid the defects caused by dust.
 - This product is conformity to RoHS directive. (※)
- (※) Conformity to RoHS Directive: This means that, in conformity with EU Directive 2002/95/EC, lead, cadmium, hexavalent chromium, and specific bromine-based flame retardants, PBB and PBDE, have not been used, except for exempted applications.

[1] Outline
1-1. Outline

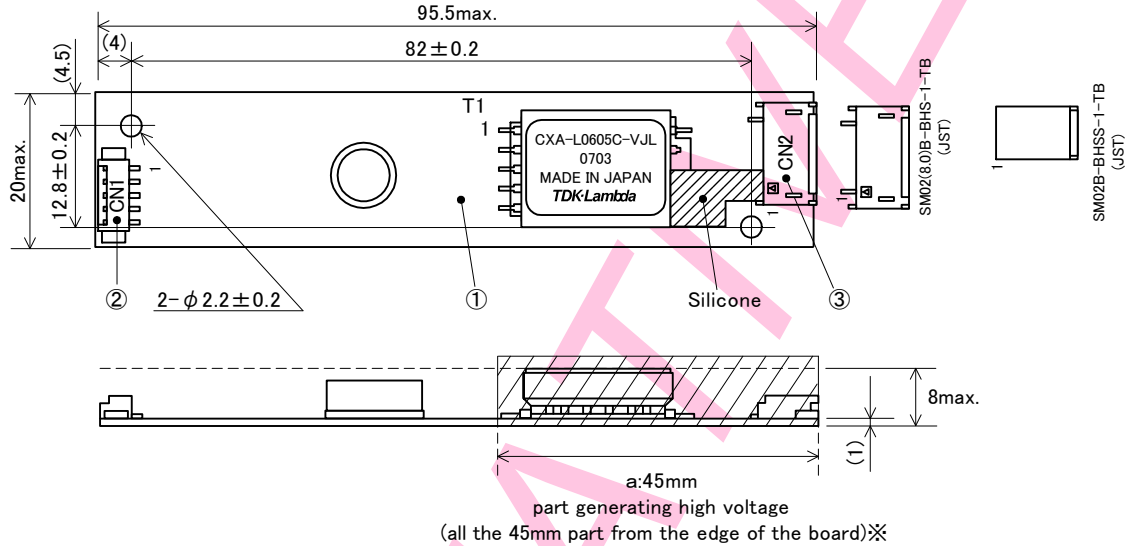

※Please secure 3mm or longer space distance from the high voltage generating area in all directions. Please see Note 1-3 for the details.

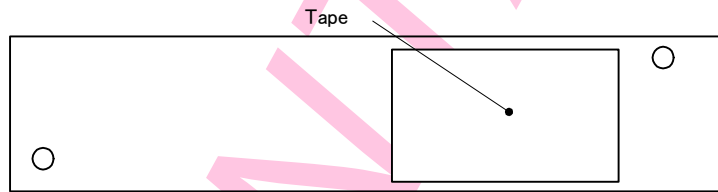

The dimensional deviation not instructed is assumed to be ±0.5mm

No.	Part Description	Material	Qu	Remark	Mates With
①	PCB	Composite (CEM-3)	1	UL94V-0 t=1.0	-
②	Input Connector CN1	53261-0571	1	Molex	51021-0500
③	Output Connector CN2	SM02(8.0)B-BHS-1-TB (LF)(SN)	1	JST	BHR-03VS-1
		SM02B-BHSS-1-TB(LF)(SN)	1	JST	BHSR-02VS-1

*Part Name example

C X A - L 0 6 0 5 C - V □ L

Inverter
Output Power: 4~5W

Output Current: 6mArms typ
Input Voltage: 5V typ

Changing of CXA-L0605-VxL

The position of High Voltage Output terminal :
L-Left side

Output Connector---J: SM02(8.0)B-BHS-1-TB (LF)(SN)
S: SM02B-BHSS-1-TB(LF)(SN)

Dimming System: Analog Dimming

No.	MATERIALS NAME	QU	MATERIAL	REMARK
PRODUCT NAME or MODEL, TITLE				
DC-AC INVERTER UNIT CXA-L0605C-VxL				
NAME OF DRAWING		DRAWING No.		PAGE
Product Drawing		CTR-3818-X		3

TDK-Lambda

1-2. Connector Configuration

Input side

Pin No.	Symbols	Ratings	Notes
CN1-1	V _{in}	4.75~5.25V	
CN1-2	GND	0V	
CN1-3	V _{rmt}	0V / 2.5V-V _{in}	0-0.4V : OFF 2.5-V _{in} : ON
CN1-4	V _{br}	0~3V	Control
CN1-5	N.C.	-	N.C.

Output side CN2

(CXA-L0605-VJL)

Pin No.	Symbols	Ratings
CN2-1	V _{HIGH}	600V _{rms} 6mArms
CN2-2	N.C.	-
CN2-3	V _{LOW}	(2V)

Output side CN2

(CXA-L0605-VSL)

Pin No.	Symbols	Ratings
CN2-1	V _{HIGH}	600V _{rms} 6mArms
CN2-2	V _{LOW}	(2V)

Note1-1. Marking of TDK part No, Date code, Country of origin.

- 1) TDK part No., Date code, Country of origin, TDK-Lambda Logo, is marked on the transformer.
- 2) Date code example. (ex. Jul. 3. 2010)

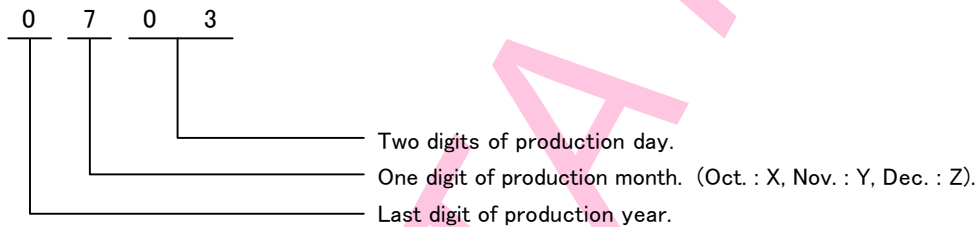

- 3) Country of origin code example. (ex. MADE IN JAPAN, MADE IN MALAYSIA).

Note1-2. For circuit connection, please refer to test circuit diagram [4].

Note1-3. Please use minimum of 3mm clearance (all directions) between inverter high voltage area and any conductors. Please refer to mechanical drawing for marking of high voltage area.

Note1-4. Open voltage (strike voltage) is measured across the transformer secondary winding at no load as the reading at the output connector would be less than the actual value.

Note1-5. If the start up voltage falls below Cold Cathode Tube strike voltage, the CCFL will not light up easily specially at lower ambient temperature. Please review mounting instruction to avoid any abnormal operation due to coupling/leakage capacitance of inverter high voltage area to any surrounding conductor.

Fig1.High Voltage Code

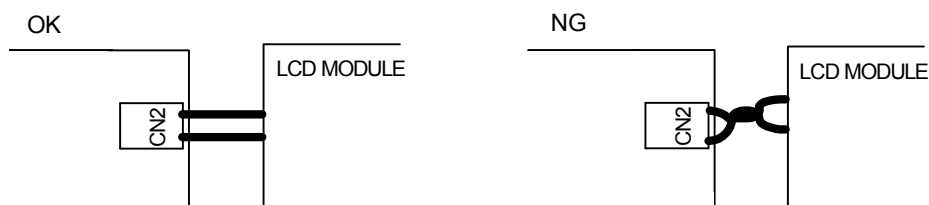

No.	MATERIALS NAME	QU	MATERIAL	REMARK
PRODUCT NAME or MODEL, TITLE				
DC-AC INVERTER UNIT CXA-L0605C-VxL				
TDK-Lambda	NAME OF DRAWING		DRAWING No.	PAGE
	Product Drawing		CTR-3818-X	4

Note1-6. Please check your lamp characteristic for minimum operational current and set the limit point in your design to avoid flickering and/or abnormal operation.

Note1-7. For proper operation of circuit protection (fuse or IC PROTECTOR), Please use minimum of 3.0A capacity for input power supply.

Note1-8. Impedance from the wire connection can cause a ripple in the input. The product has an internal fuse of 1.5A. Please check that input current peak wave form does not exceed 1.5A.

[2] Absolute maximum ratings

Items	Symbols	Specification	Unit	Notes
Input Voltage	Vin	0~5.25	V	
Load Resistance	RL	110max.	kΩ	
Operating Temp. range	Ta	-20~70	°C	
Storage Temp. range	Ts	-30~85	°C	
Humidity range	RH	95	%RH	A maximum wet ball temperature is 38°C No dew.

[3] Electrical specifications

Item	Symbol	Conditions				Specifications			Unit
		Vin [V]	Ta [°C]	RL [kΩ]	Vbr [V]	MIN.	TYP.	MAX.	
Output Current (Dimmingmax.)	lout1	4.75~5.25	23±5	80	0	5.4	6	6.6	mArms
	lout2	4.75~5.25	-20~70	80	0	5.3	6	6.7	
Output Current (Dimmingmin.)	lout3	4.75~5.25	23±5	80	3	2.4	3	3.6	
Input Current	Iin	5	-20~70	80	0	-	0.8	1.0	A
Frequency	F	4.75~5.25	-20~70	80	0	35	45	55	kHz
Open Circuit Voltage	Vopen	4.75~5.25	-20~70	∞	0~3	1.5	1.6	-	kVrms

No.	MATERIALS NAME	QU	MATERIAL	REMARK
PRODUCT NAME or MODEL, TITLE				
DC-AC INVERTER UNIT CXA-L0605C-VxL				
NAME OF DRAWING			DRAWING No.	PAGE
Product Drawing			CTR-3818-X	5

TDK-Lambda

[4] Test circuit

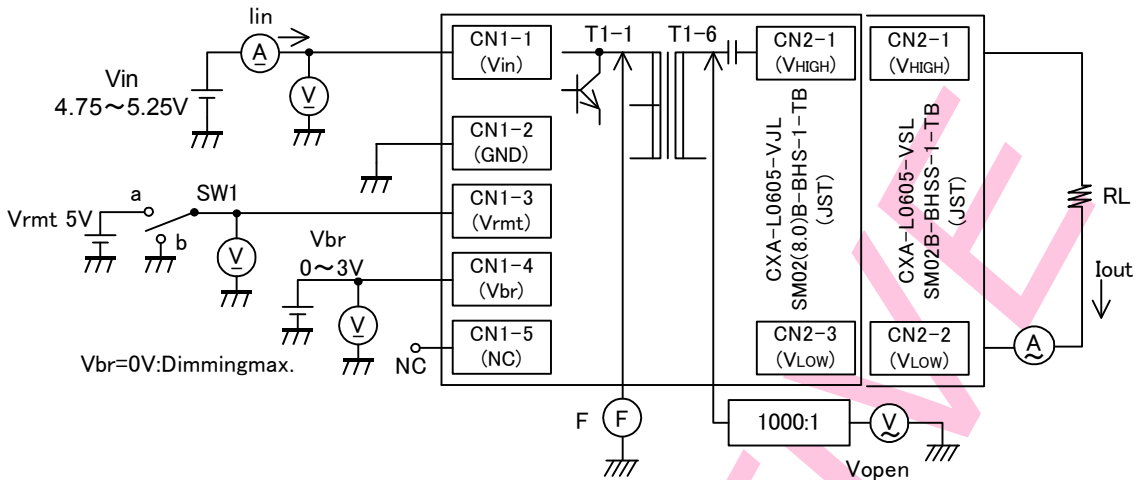

Note.4-1.SW1(ON/OFF) Operation is as following;

SW1	Operation of unit
a	Operation
b	Non operation
Open	Non operation

Note4-2.Safety Function

- Digital Multiple Meter(ADVA NTEST R6451A or equivalent)
- DC Current Meter(ADVANTEST R6451A or equivalent)
- Frequency Countor(ADVANTE ST R6452A or equivalent)
- True RMS Meter(KEITHLEY 2001 or equivalent.)
- High Frequency Current Meter r(KEITHLEY 2001 or equivalent)
- High Voltage Probe (Tektronix P3000 or equivalent)

LCD module Connected chart (reference)

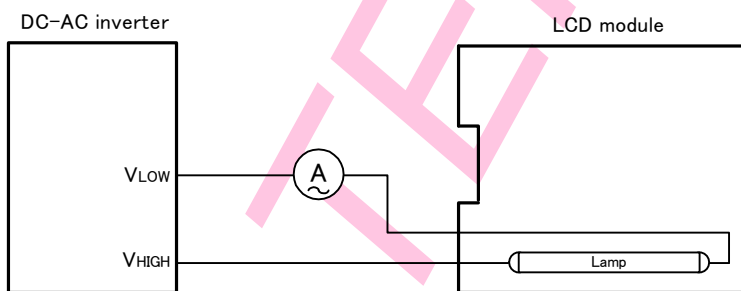

Vbrmt terminal circuit (Reference)

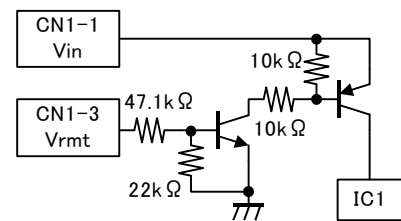

Connect the High Frequency Current Meter to the Low-Voltage (VLOW) side.

No.	MATERIALS NAME	QU	MATERIAL	REMARK
PRODUCT NAME or MODEL, TITLE				
DC-AC INVERTER UNIT CXA-L0605C-VxL				
NAME OF DRAWING		DRAWING No.		PAGE
Product Drawing		CTR-3818-X		6

TDK-Lambda

[5] Reliability test

Following test items are assured.

Items	Conditions	Judgement
Low Temp. Non operational	-30°C 500h	Electrical and apperance should be in the spec.
Low Temp.operational	-30°C 500h Load cond.:TYP	
High Temp. Non operational	85°C 500h	
High Temp.operational	80°C 500h Load cond.:TYP	
Heat shock	-30°C to 80°C 30min.Each 100 Cycles	
Humidity (Non operational)	60°C 90~95%RH 500h	
Vibration	10~57Hz Amplitude 0.75mm or 9.8m/s ² 58~500Hz 9.8m/s ² Sweep:11min 60min each axis X,Y,Z	
Shock	980m/s ² 11ms Harf-sine pulse 1 time each axis ±X,Y,Z	

No.	MATERIALS NAME	QU	MATERIAL	REMARK
PRODUCT NAME or MODEL,TITLE				
DC-AC INVERTER UNIT CXA-L0605C-VxL				
NAME OF DRAWING			DRAWING No.	PAGE
Product Drawing			CTR-3818-X	7

TDK-Lambda

[6] Packing and Marking

A shipping box is packaged to avoid from water or damage. Following items are printed on the box.

- 6-1. TDK part No. CXA-L0605C-VxL
- 6-2. Manufacture
- 6-3. QTY.

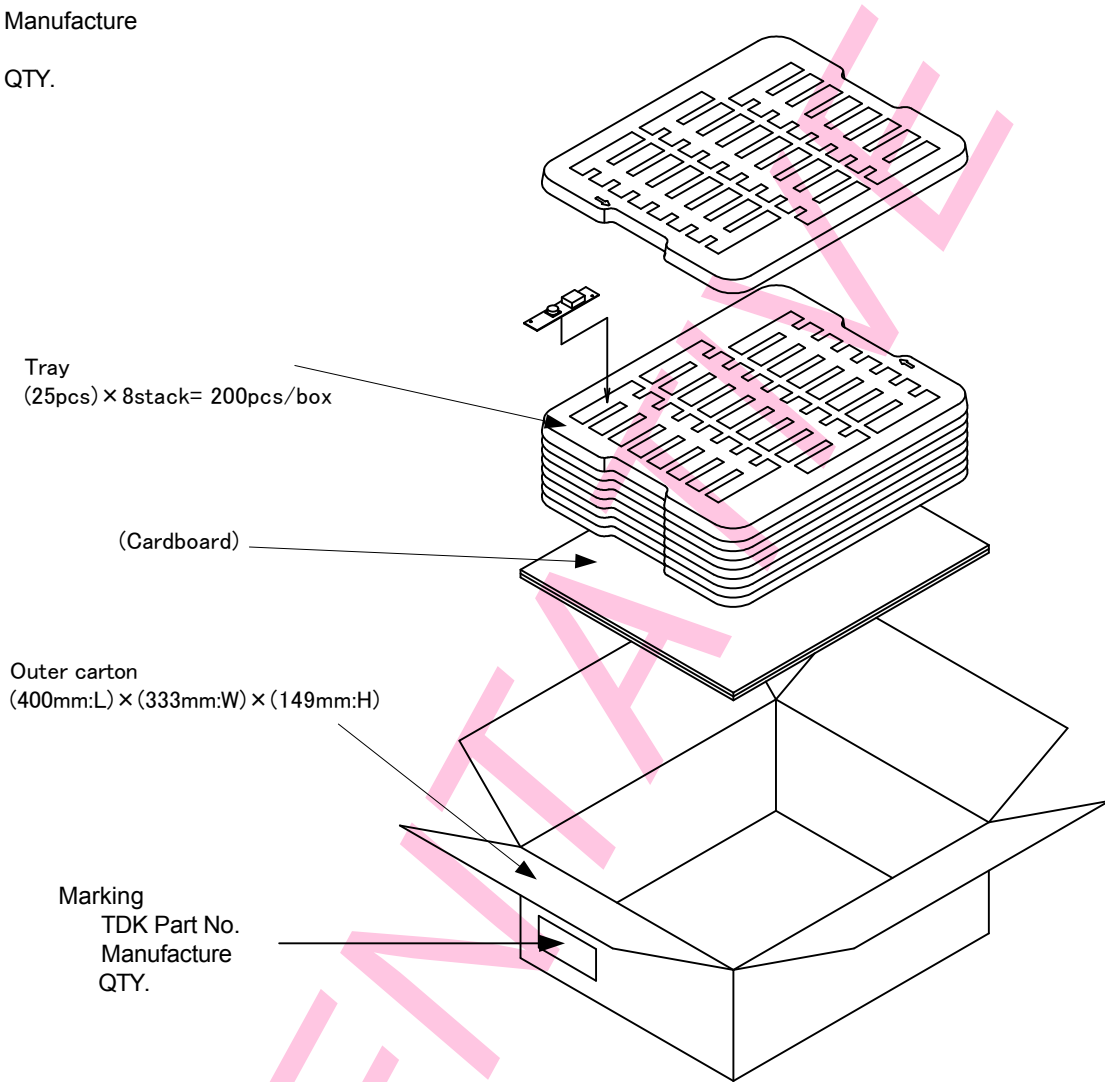

[7] Others

7-1. Test conditions

Unless otherwise specified, the temperature to be (25±15)°C and humidity to be (65±20) %RH.

7-2. Warranty

Warranty shall be for one year after delivery, and those products causing failure during the warranty period and which failures are attributed to the manufacturer's responsibility shall be replaced at no charge.

7-3. Others

When any doubt arises about this specification, it shall be discussed and decided upon between both parties. Shipment inspection result sheet are subject to change without notice.

No.	MATERIALS NAME	QU	MATERIAL	REMARK
PRODUCT NAME or MODEL, TITLE				
DC-AC INVERTER UNIT CXA-L0605C-VxL				
TDK-Lambda	NAME OF DRAWING		DRAWING No.	PAGE
	Product Drawing		CTR-3818-X	8