



Chipsmall Limited consists of a professional team with an average of over 10 year of expertise in the distribution of electronic components. Based in Hongkong, we have already established firm and mutual-benefit business relationships with customers from,Europe,America and south Asia,supplying obsolete and hard-to-find components to meet their specific needs.

With the principle of “Quality Parts,Customers Priority,Honest Operation,and Considerate Service”,our business mainly focus on the distribution of electronic components. Line cards we deal with include Microchip,ALPS,ROHM,Xilinx,Pulse,ON,Everlight and Freescale. Main products comprise IC,Modules,Potentiometer,IC Socket,Relay,Connector.Our parts cover such applications as commercial,industrial, and automotives areas.

We are looking forward to setting up business relationship with you and hope to provide you with the best service and solution. Let us make a better world for our industry!



Contact us

Tel: +86-755-8981 8866 Fax: +86-755-8427 6832

Email & Skype: info@chipsmall.com Web: www.chipsmall.com

Address: A1208, Overseas Decoration Building, #122 Zhenhua RD., Futian, Shenzhen, China



1 Mbit (128K x 8) nvSRAM With Real Time Clock

Features

- 25 ns, 35 ns, and 45 ns access times
- Pin compatible with STK17TA8
- Data integrity of Cypress nvSRAM combined with full featured Real Time Clock (RTC)
 - Low power, 350 nA RTC current
 - Capacitor or battery backup for RTC
- Watchdog timer
- Clock alarm with programmable interrupts
- Hands off automatic STORE on power down with only a small capacitor
- STORE to QuantumTrap™ initiated by software, device pin, or on power down
- RECALL to SRAM initiated by software or on power up
- Infinite READ, WRITE, and RECALL cycles
- High reliability

- Endurance to 200K cycles
- Data retention: 20 years at 55°C
- Single 3V operation with tolerance of +20%, -10%
- Commercial and industrial temperature
- 48-Pin SSOP package (ROHS compliant)

Functional Description

The Cypress CY14B101K combines a 1 Mbit nonvolatile static RAM with a full featured real time clock in a monolithic integrated circuit. The embedded nonvolatile elements incorporate QuantumTrap technology producing the world's most reliable nonvolatile memory. The SRAM is read and written an infinite number of times, while independent, nonvolatile data resides in the nonvolatile elements.

The Real Time Clock function provides an accurate clock with leap year tracking and a programmable high accuracy oscillator. The alarm function is programmable for one time alarm or periodic seconds, minutes, hours, or days. There is also a programmable watchdog timer for process control.

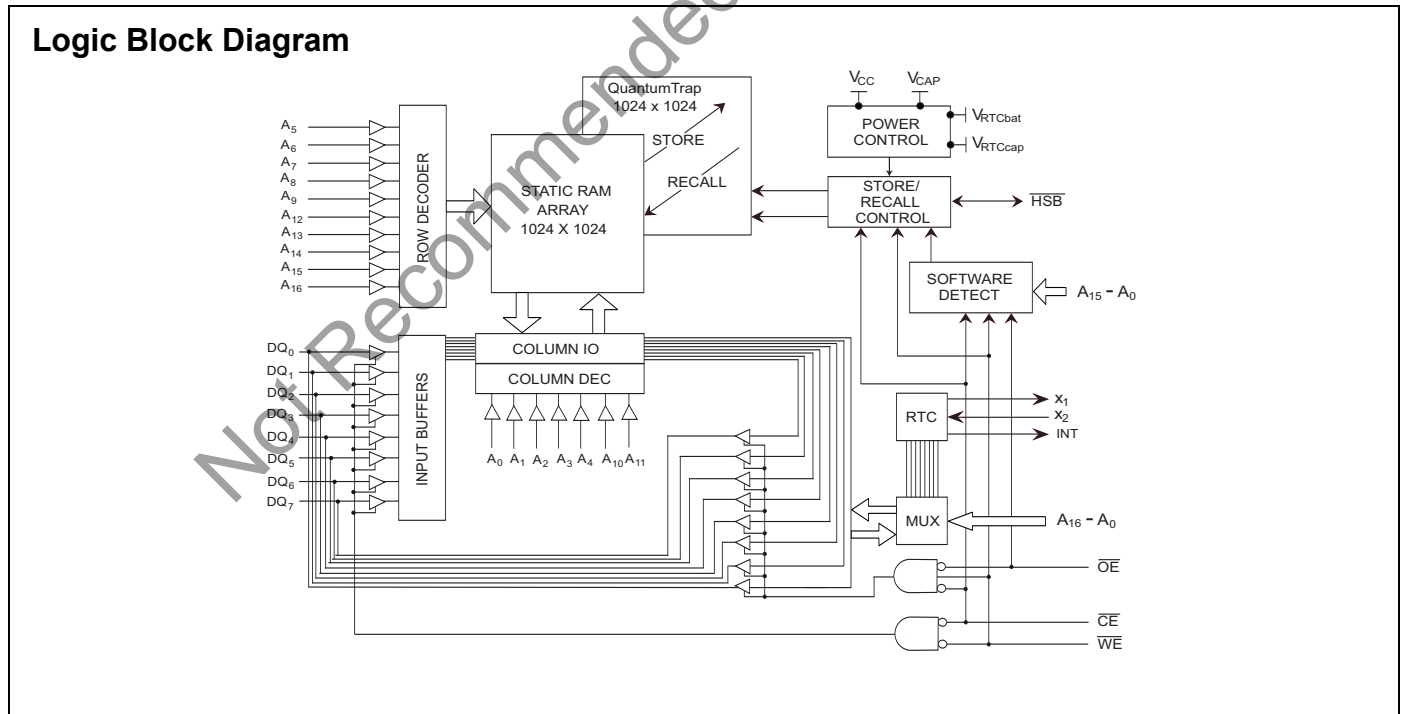

Contents

Features	1	Interrupts	10
Functional Description	1	Interrupt Register	10
Logic Block Diagram	1	Flags Register	10
Contents	2	Maximum Ratings	16
Pin Configurations	3	Operating Range	16
Device Operation	4	DC Electrical Characteristics	16
SRAM READ	4	Data Retention and Endurance	17
SRAM WRITE	4	Capacitance	17
AutoStore® Operation	4	Thermal Resistance	17
Hardware STORE (HSB) Operation	4	AC Test Conditions	17
Hardware RECALL (Power Up)	5	AC Switching Characteristics	18
Software STORE	5	AC Switching Characteristics (continued)	19
Software RECALL	5	AutoStore or Power Up RECALL	20
Data Protection	5	Software Controlled STORE/RECALL Cycles	21
Noise Considerations	5	Hardware STORE Cycle	22
Low Average Active Power	6	Soft Sequence Commands	22
Best Practices	6	RTC Characteristics	23
Real Time Clock Operation	8	Truth Table For SRAM Operations	23
nvTIME Operation	8	Part Numbering Nomenclature	24
Clock Operations	8	Ordering Information	25
Reading the Clock	8	Package Diagrams	26
Setting the Clock	8	Document History Page	27
Backup Power	8	Sales, Solutions, and Legal Information	29
Stopping and Starting the Oscillator	8	Worldwide Sales and Design Support	29
Calibrating the Clock	9	Products	29
Alarm	9		
Watchdog Timer	9		
Power Monitor	10		

Not Recommended for New Designs

Pin Configurations

Figure 1. 48-Pin SSOP

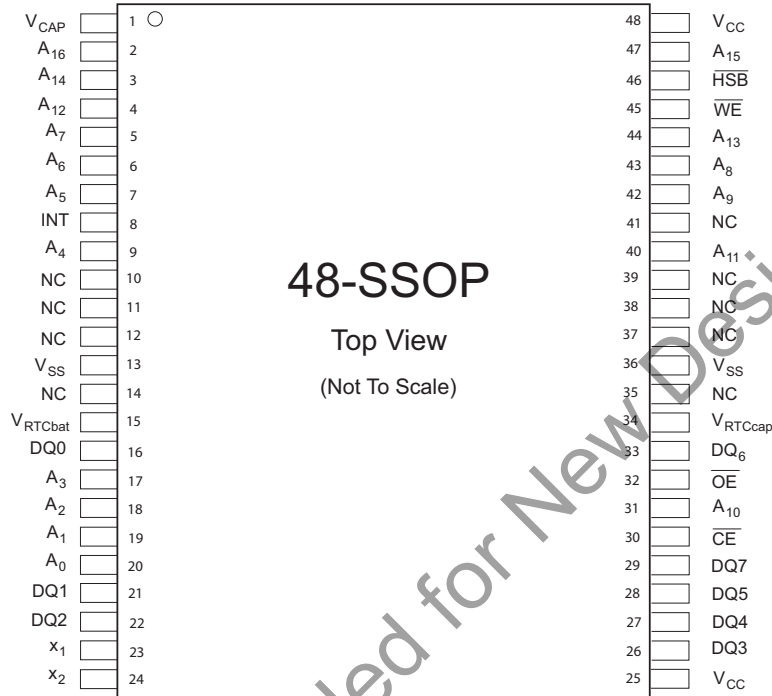

Table 1. Pin Definitions

Pin Name	Alt	I/O Type	Description
A ₀ – A ₁₆		Input	Address Inputs. Used to select one of the 131,072 bytes of the nvSRAM.
DQ ₀ – DQ ₇		Input Output	Bidirectional Data I/O Lines. Used as input or output lines depending on operation
NC		No Connect	No Connects. This pin is not connected to the die
\overline{WE}	\overline{W}	Input	Write Enable Input, Active LOW. When the chip is enabled and \overline{WE} is LOW, data on the I/O pins is written to the specific address location.
\overline{CE}	\overline{E}	Input	Chip Enable Input, Active LOW. When LOW, selects the chip. When HIGH, deselects the chip.
\overline{OE}	\overline{G}	Input	Output Enable, Active LOW. The active low \overline{OE} input enables the data output buffers during READ cycles. Deasserting \overline{OE} high causes the I/O pins to tri-state.
X ₁		Output	Crystal Connection Drives crystal on start up.
X ₂		Input	Crystal Connection for 32.768 kHz crystal.
V _{RTCap}		Power Supply	Capacitor Supplied Backup RTC Supply Voltage. (Left unconnected if V _{RTCap} is used)
V _{RTCap}		Power Supply	Battery Supplied Backup RTC Supply Voltage. (Left unconnected if V _{RTCap} is used)
INT		Output	Interrupt Output. Program to respond to the clock alarm, the watchdog timer, and the power monitor. Programmable to either active HIGH (push or pull) or LOW (open drain).
V _{SS}		Ground	Ground for the Device. Must be connected to ground of the system.
V _{CC}		Power Supply	Power Supply Inputs to the Device.
HSB		Input Output	Hardware Store Busy. When LOW this output indicates a Hardware Store is in progress. When pulled LOW external to the chip it initiates a nonvolatile STORE operation. A weak internal pull up resistor keeps this pin HIGH if not connected (connection optional).
V _{CAP}		Power Supply	AutoStore™ Capacitor. Supplies power to nvSRAM during power loss to store data from SRAM to nonvolatile elements.

Device Operation

The CY14B101K nvSRAM consists of two functional components paired in the same physical cell. The components are SRAM memory cell and a nonvolatile QuantumTrap cell. The SRAM memory cell operates as a standard fast static RAM. Data in the SRAM is transferred to the nonvolatile cell (the STORE operation), or from the nonvolatile cell to SRAM (the RECALL operation). Using this unique architecture, all cells are stored and recalled in parallel. During the STORE and RECALL operations, SRAM READ and WRITE operations are inhibited. The CY14B101K supports infinite reads and writes similar to a typical SRAM. In addition, it provides infinite RECALL operations from the nonvolatile cells and up to 200K STORE operations.

See the “[Truth Table For SRAM Operations](#)” on page 23 for a complete description of read and write modes.

SRAM READ

The CY14B101K performs a READ cycle whenever \overline{CE} and \overline{OE} are LOW while WE and HSB are HIGH. The address specified on pins A₀₋₁₆ determines which of the 131,072 data bytes are accessed. When the READ is initiated by an address transition, the outputs are valid after a delay of t_{AA} (see [Figure 8](#) on page 18). If the READ is initiated by CE or OE, the outputs are valid at t_{ACE} or at t_{DOE}, whichever is later (see [Figure 9](#) on page 18). The data outputs repeatedly respond to address changes within the t_{AA} access time without the need for transitions on any control input pins. This remains valid until another address change or until CE or OE is brought HIGH, or WE or HSB is brought LOW.

SRAM WRITE

A WRITE cycle is performed whenever \overline{CE} and \overline{WE} are LOW and HSB is HIGH. The address inputs must be stable before entering the WRITE cycle and must remain stable until either CE or WE go HIGH at the end of the cycle. The data on the common I/O pins DQ₀₋₇ is written into the memory if the data is valid t_{SD} before the end of a WE controlled WRITE or before the end of an CE controlled WRITE. Keep OE HIGH during the entire WRITE cycle to avoid data bus contention on common I/O lines. If OE is left LOW, internal circuitry turns off the output buffers t_{HZWE} after WE goes LOW.

AutoStore® Operation

The CY14B101K stores data to nvSRAM using one of three storage operations:

1. Hardware Store activated by \overline{HSB}
2. Software Store activated by an address sequence
3. AutoStore on device power down

AutoStore operation is a unique feature of QuantumTrap technology and is enabled by default on the CY14B101K.

During normal operations, the device draws current from V_{CC} to charge a capacitor connected to the V_{CAP} pin. This stored charge is used by the chip to perform a single STORE operation. If the voltage on the V_{CC} pin drops below V_{SWITCH}, the part

automatically disconnects the V_{CAP} pin from V_{CC}. A STORE operation is initiated with power provided by the V_{CAP} capacitor.

Figure 2. AutoStore Mode

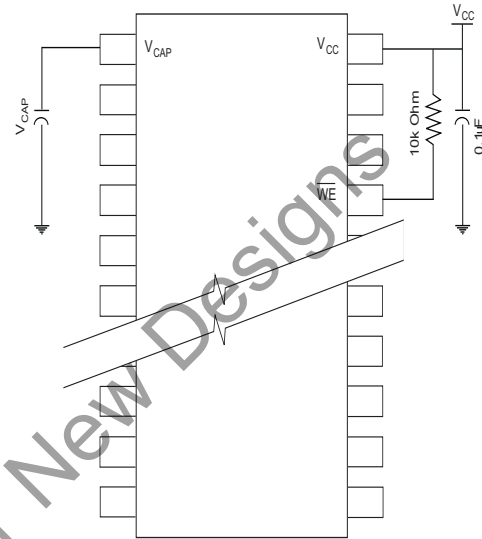

Figure 2 shows the proper connection of the storage capacitor (V_{CAP}) for automatic store operation. Refer to [DC Electrical Characteristics](#) on page 16 for the size of the V_{CAP}. The voltage on the V_{CAP} pin is driven to 5V by a charge pump internal to the chip. A pull up should be placed on WE to hold it inactive during power up. This pull up is only effective if the WE signal is tri-state during power up. Many MPUs tri-state their controls on power up. Verify this when using the pull up. When the nvSRAM comes out of power-on-recall, the MPU must be active or the WE held inactive until the MPU comes out of reset.

To reduce unnecessary nonvolatile stores, AutoStore and Hardware Store operations are ignored unless at least one WRITE operation takes place since the most recent STORE or RECALL cycle. Software initiated STORE cycles are performed regardless of whether a WRITE operation took place. Monitor the HSB signal by the system to detect if an AutoStore cycle is in progress.

Hardware STORE (\overline{HSB}) Operation

The CY14B101K provides the \overline{HSB} pin for controlling and acknowledging the STORE operations. Use the \overline{HSB} pin to request a hardware STORE cycle. When the \overline{HSB} pin is driven LOW, the CY14B101K conditionally initiates a STORE operation after t_{DELAY}. An actual STORE cycle only begins if a WRITE to the SRAM has taken place since the last STORE or RECALL cycle. The \overline{HSB} pin also acts as an open drain driver that is internally driven LOW to indicate a busy condition while the STORE (initiated by any means) is in progress. This pin is externally pulled up if it is used to drive other inputs.

SRAM READ and WRITE operations that are in progress when HSB is driven LOW by any means are given time to complete before the STORE operation is initiated. After HSB goes LOW, the CY14B101K continues SRAM operations for t_{DELAY} . During t_{DELAY} , multiple SRAM READ operations take place. If a WRITE is in progress when HSB is pulled LOW, it is allowed a time, t_{DELAY} , to complete. However, any SRAM WRITE cycles requested after HSB goes LOW are inhibited until HSB returns HIGH.

During any STORE operation, regardless of how it is initiated, the CY14B101K continues to drive the HSB pin LOW, releasing it only when the STORE is complete. After completing the STORE operation, the CY14B101K remains disabled until the HSB pin returns HIGH. Leave the HSB unconnected if it is not used.

Hardware RECALL (Power Up)

During power up or after any low power condition ($V_{\text{CC}} < V_{\text{SWITCH}}$), an internal RECALL request is latched. When V_{CC} again exceeds the sense voltage of V_{SWITCH} , a RECALL cycle automatically initiates and takes t_{HRECALL} to complete.

Software STORE

Data is transferred from the SRAM to the nonvolatile memory by a software address sequence. The CY14B101K software STORE cycle is initiated by executing sequential $\overline{\text{CE}}$ controlled READ cycles from six specific address locations in exact order. During the STORE cycle, an erase of the previous nonvolatile data is first performed followed by a program of the nonvolatile elements. After a STORE cycle is initiated, further READs and WRITEs are inhibited until the cycle is completed.

Because a sequence of READs from specific addresses is used for STORE initiation, it is important that no other READ or WRITE accesses intervene in the sequence. If it intervenes, the sequence is aborted and no STORE or RECALL takes place.

To initiate the software STORE cycle, the following READ sequence are performed:

1. Read Address 0x4E38 Valid READ
2. Read Address 0xB1C7 Valid READ
3. Read Address 0x83E0 Valid READ
4. Read Address 0x7C1F Valid READ
5. Read Address 0x703F Valid READ
6. Read Address 0x8FC0 Initiate STORE cycle

The software sequence is clocked with $\overline{\text{CE}}$ controlled READs or OE controlled READs. After the sixth address in the sequence is entered, the STORE cycle commences and the chip is disabled. It is important to use read cycles and not write cycles in the sequence, although it is not necessary that OE be LOW for a valid sequence. After the t_{STORE} cycle time is fulfilled, the SRAM is activated again for READ and WRITE operation.

Software RECALL

Data is transferred from the nonvolatile memory to the SRAM by a software address sequence. A software RECALL cycle is initiated with a sequence of READ operations in a manner similar to the software STORE initiation. To initiate the RECALL cycle, the following sequence of $\overline{\text{CE}}$ controlled READ operations are performed:

1. Read Address 0x4E38 Valid READ
2. Read Address 0xB1C7 Valid READ
3. Read Address 0x83E0 Valid READ
4. Read Address 0x7C1F Valid READ
5. Read Address 0x703F Valid READ
6. Read Address 0x4C63 Initiate RECALL Cycle

Internally, RECALL is a two step procedure. First, the SRAM data is cleared and then the nonvolatile information is transferred into the SRAM cells. After the t_{RECALL} cycle time, the SRAM is again ready for READ and WRITE operations. The RECALL operation does not alter the data in the nonvolatile elements.

Data Protection

The CY14B101K protects data from corruption during low voltage conditions by inhibiting all externally initiated STORE and WRITE operations. The low voltage condition is detected when V_{CC} is less than V_{SWITCH} . If the CY14B101K is in a WRITE mode (both $\overline{\text{CE}}$ and $\overline{\text{WE}}$ LOW) at power up, after a RECALL or after a STORE, the WRITE is inhibited until a negative transition on $\overline{\text{CE}}$ or $\overline{\text{WE}}$ is detected. This protects against inadvertent writes during power up or brownout conditions.

Noise Considerations

The CY14B101K is a high speed memory and must have a high frequency bypass capacitor of approximately 0.1 μF connected between V_{CC} and V_{SS} , using leads and traces that are as short as possible. As with all high speed CMOS ICs, careful routing of power, ground, and signals reduce circuit noise.

Low Average Active Power

CMOS technology provides the CY14B101K the benefit of drawing significantly less current when it is cycled at times longer than 50 ns. Figure 3 shows the relationship between I_{CC} and READ/WRITE Cycle Time. The worst case current consumption is shown for commercial temperature range, $V_{CC} = 3.6V$, and chip enable at maximum frequency. Only standby current is drawn when the chip is disabled.

The overall average current drawn by the CY14B101K depends on the following items:

- The duty cycle of chip enable
- The overall cycle rate for accesses
- The ratio of READs to WRITEs
- The operating temperature
- The V_{CC} level
- I/O loading

Figure 3. Current versus Cycle Time

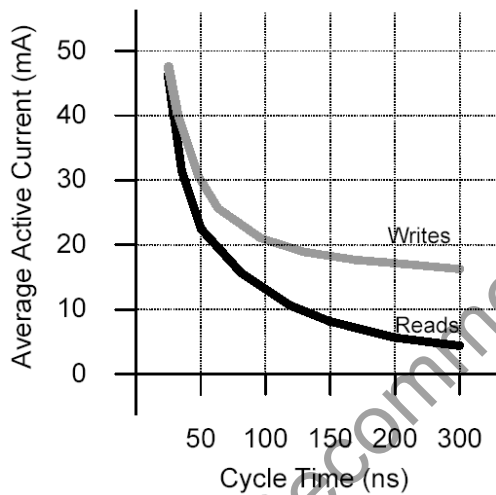

Best Practices

nvSRAM products have been used effectively for over 15 years. While ease-of-use is one of the product’s main system values, experience gained working with hundreds of applications has resulted in the following suggestions as best practices:

- The nonvolatile cells in an nvSRAM are programmed on the test floor during final test and quality assurance. Incoming inspection routines at customer or contract manufacturer’s sites sometimes reprograms these values. Final NV patterns are typically repeating patterns of AA, 55, 00, FF, A5, or 5A. The end product’s firmware should not assume that an NV array is in a set programmed state. Routines that check memory content values to determine first time system configuration and cold or warm boot status, must always program a unique NV pattern (for example, complex 4-byte pattern of 46 E6 49 53 hex or more random bytes) as part of the final system manufacturing test to ensure these system routines work consistently.
- The OSCEN bit in the Calibration register at 0x1FFF8 should be set to 1 to preserve battery life when the system is in storage (see [Stopping and Starting the Oscillator](#) on page 8).
- The Vcap value specified in this data sheet includes a minimum and a maximum value size. The best practice is to meet this requirement and not exceed the maximum Vcap value because the higher inrush currents may reduce the reliability of the internal pass transistor. Customers who want to use a larger Vcap value to make sure there is extra store charge should discuss their Vcap size selection with Cypress.

Table 2. Mode Selection

$\overline{\text{CE}}$	$\overline{\text{WE}}$	$\overline{\text{OE}}$	A15 – A0	Mode	I/O	Power
H	X	X	X	Not Selected	Output High Z	Standby
L	H	L	X	READ SRAM	Output Data	Active
L	L	X	X	WRITE SRAM	Input Data	Active
L	H	L	0x4E38 0xB1C7 0x83E0 0x7C1F 0x703F 0x8FC0	Read SRAM Read SRAM Read SRAM Read SRAM Read SRAM Nonvolatile STORE	Output Data Output Data Output Data Output Data Output Data Output High Z	Active $I_{CC2}^{[1, 2, 3]}$
L	H	L	0x4E38 0xB1C7 0x83E0 0x7C1F 0x703F 0x4C63	Read SRAM Read SRAM Read SRAM Read SRAM Read SRAM Nonvolatile RECALL	Output Data Output Data Output Data Output Data Output Data Output High Z	Active ^[1, 2, 3]

Not Recommended for New Designs

Notes

1. The six consecutive address locations are in the order listed. $\overline{\text{WE}}$ is HIGH during all six cycles to enable a nonvolatile cycle.
2. While there are 17 address lines on the CY14B101K, only the lower 16 lines are used to control software modes.
3. O state depends on the state of $\overline{\text{OE}}$. The I/O table shown is based on $\overline{\text{OE}}$ Low.

Real Time Clock Operation

nvTIME Operation

The CY14B101K offers internal registers that contain clock, alarm, watchdog, interrupt, and control functions. RTC registers use the last 16 address locations of the SRAM. Internal double buffering of the clock and the clock or timer information registers prevents accessing transitional internal clock data during a READ or WRITE operation. Double buffering also circumvents disrupting normal timing counts or clock accuracy of the internal clock while accessing clock data. Clock and Alarm Registers store data in BCD format.

The RTC register addresses for CY14B101K range from 0x1FFF0 to 0x1FFFF. Refer to [RTC Register Map](#)[5, 6] on page 12 and [Register Map Detail](#) on page 13 for detailed description.

Clock Operations

The clock registers maintain time up to 9,999 years in one second increments. The user sets the time to any calendar time and the clock automatically keeps track of days of the week, month, leap years, and century transitions. There are eight registers dedicated to the clock functions that are used to set time with a WRITE cycle and to READ time during a READ cycle. These registers contain the Time of Day in BCD format. Bits defined as '0' are currently not used and are reserved for future use by Cypress.

Reading the Clock

The double buffered RTC register structure reduces the chance of reading incorrect data from the clock. The user should stop internal updates to the CY14B101K time keeping registers before reading clock data, to prevent reading of data in transition. Stopping the internal register updates does not affect clock accuracy.

The updating process is stopped by writing a '1' to the read bit 'R' (in the flags register at 0x1FFF0), and does not restart until a '0' is written to the read bit. The RTC registers are then read while the internal clock continues to run. After a '0' is written to the read bit ('R'), all CY14B101K registers are simultaneously updated within 20 ms.

Setting the Clock

Setting the write bit 'W' (in the flags register at 0x1FFF0) to a '1' stops updates to the time keeping registers and enables the time to be set. The correct day, date, and time are then written into the registers in 24 hour BCD format. The time written is referred to as the 'Base Time'. This value is stored in nonvolatile registers and used in calculation of the current time. Resetting the WRITE bit to '0' transfers those values to the actual clock counters, after which the clock resumes normal operation.

Backup Power

The RTC in the CY14B101K is intended for permanently powered operations. Either the V_{RTCCap} or V_{RTCbat} pin is connected depending on whether a capacitor or battery is chosen for the application. When the primary power, V_{CC} , fails and drops below V_{SWITCH} , the device switches to the backup power supply.

The clock oscillator uses very little current to maximize the backup time available from the backup source. Regardless of clock operation with the primary source removed, the data stored in nvSRAM is secure, as it is stored in the nonvolatile elements when power was lost.

During backup operation, the CY14B101K consumes a maximum of 300 nA at 2V. The user should choose capacitor or battery values according to the application.

Backup time values, based on maximum current specifications, are shown in the following table. Nominal times are approximately three times longer.

Table 3. RTC Backup Time

Capacitor Value	Backup Time
0.1F	72 hours
0.47F	14 days
1.0F	30 days

Using a capacitor has the obvious advantage of recharging the backup source each time the system is powered up. If a battery is used, use a 3V lithium; the CY14B101K only sources current from the battery when the primary power is removed. However, the battery is not recharged at any time by the CY14B101K. The battery capacity is chosen for total anticipated cumulative downtime required over the life of the system.

Stopping and Starting the Oscillator

The OSCEN bit in the calibration register at 0x1FFF8 controls the enable and disable of the oscillator. This active LOW bit is nonvolatile and is shipped to customers in the "enabled" (set to 0) state. To preserve the battery life when the system is in storage, OSCEN bit must be set to '1'. This turns off the oscillator circuit, extending the battery life. If the OSCEN bit goes from disabled to enabled, it takes approximately 5 seconds (10 seconds maximum) for the oscillator to start.

While system power is off, if the voltage on the backup supply (V_{RTCCap} or V_{RTCbat}) falls below their respective minimum level, the oscillator may fail. The CY14B101K has the ability to detect oscillator failure when system power is restored. This is recorded in the OSCF (Oscillator Failed bit) of the Flags register at address 0x1FFF0. When the device is powered on (V_{CC} goes above V_{SWITCH}), the OSCEN bit is checked for "enabled" status. If the OSCEN bit is enabled and the oscillator is not active within the first 5 ms, the OSCF bit is set to "1". The system must check for this condition and then write '0' to clear the flag. Note that in addition to setting the OSCF flag bit, the time registers are reset to the "Base Time" (see [Setting the Clock](#) on page 8), which is the value last written to the time keeping registers. The Control or Calibration registers and the OSCEN bit are not affected by the "oscillator failed" condition.

The value of OSCF must be reset to '0' when the time registers are written for the first time. This initializes the state of this bit which may have become set when the system was first powered on.

To reset OSCF, set the write bit "W" (in the flags register at 0x1FFF0) to "1" to enable writes to the Flag register. Write a "0" to the OSCF bit and then reset the write bit to "0" to disable writes.

Calibrating the Clock

The RTC is driven by a quartz controlled oscillator with a nominal frequency of 32.768 kHz. Clock accuracy depends on the quality of the crystal and calibration. The crystal oscillators typically have an error of ± 20 ppm to ± 35 ppm. However, CY14B101K employs a calibration circuit that improves the accuracy to $+1/-2$ ppm at 25°C. This implies an error of +2.5 seconds to -5 seconds per month.

The calibration circuit adds or subtracts counts from the oscillator divider circuit to achieve this accuracy. The number of pulses that are suppressed (subtracted, negative calibration) or split (added, positive calibration) depends upon the value loaded into the five calibration bits found in Calibration register at 0x1FFF8. The calibration bits occupy the five lower order bits in the Calibration register. These bits are set to represent any value between '0' and 31 in binary form. Bit D5 is a sign bit, where a '1' indicates positive calibration and a '0' indicates negative calibration. Adding counts speeds the clock up and subtracting counts slows the clock down. If a binary '1' is loaded into the register, it corresponds to an adjustment of 4.068 or -2.034 ppm offset in oscillator error, depending on the sign.

Calibration occurs within a 64 minute cycle. The first 62 minutes in the cycle may, once per minute, have one second shortened by 128 or lengthened by 256 oscillator cycles. If a binary '1' is loaded into the register, only the first two minutes of the 64 minute cycle is modified. If a binary 6 is loaded, the first 12 are affected, and so on. Therefore, each calibration step has the effect of adding 512 or subtracting 256 oscillator cycles for every 125,829,120 actual oscillator cycles, that is, 4.068 or -2.034 ppm of adjustment per calibration step in the Calibration register.

To determine the required calibration, the CAL bit in the Flags register (0x1FFF0) must be set to '1'. This causes the INT pin to toggle at a nominal frequency of 512 Hz. Any deviation measured from the 512 Hz indicates the degree and direction of the required correction. For example, a reading of 512.01024 Hz indicates a +20 ppm error. Hence, a decimal value of -10 (001010b) must be loaded into the Calibration register to offset this error.

Note Setting or changing the Calibration register does not affect the test output frequency.

To set or clear CAL, set the write bit "W" (in the flags register at 0x1FFF0) to "1" to enable writes to the Flag register. Write a value to CAL, and then reset the write bit to "0" to disable writes.

Alarm

The alarm function compares user programmed values of alarm time and date (stored in the registers 0x1FFF1-5) with the corresponding time of day and date values. When a match occurs, the alarm internal flag (AF) is set and an interrupt is generated on INT pin if Alarm Interrupt Enable (AIE) bit is set.

There are four alarm match fields - date, hours, minutes, and seconds. Each of these fields has a match bit that is used to determine if the field is used in the alarm match logic. Setting the match bit to '0' indicates that the corresponding field is used in

the match process. Depending on the match bits, the alarm occurs as specifically as once a month or as frequently as once every minute. Selecting none of the match bits (all 1s) indicates that no match is required and therefore, alarm is disabled. Selecting all match bits (all 0s) causes an exact time and date match.

There are two ways to detect an alarm event: by reading the AF flag or monitoring the INT pin. The AF flag in the flags register at 0x1FFF0 indicates that a date or time match has occurred. The AF bit is set to "1" when a match occurs. Reading the flags or control register clears the alarm flag bit (and all others). A hardware interrupt pin may also be used to detect an alarm event.

Note CY14B101K requires the alarm match bit for seconds (0x1FFF2 - D7) to be set to '0' for proper operation of Alarm Flag and Interrupt.

Alarm registers are not nonvolatile and, therefore, need to be reinitialized by software on power up. To set, clear or enable an alarm, set the 'W' bit (in Flags Register - 0x1FFF0) to '1' to enable writes to Alarm Registers. After writing the alarm value, clear the 'W' bit back to "0" for the changes to take effect.

Watchdog Timer

The Watchdog Timer is a free running down counter that uses the 32 Hz clock (31.25 ms) derived from the crystal oscillator. The oscillator must be running for the watchdog to function. It begins counting down from the value loaded in the Watchdog Timer register.

The timer consists of a loadable register and a free running counter. On power up, the watchdog time out value in register 0x1FFF7 is loaded into the Counter Load register. Counting begins on power up and restarts from the loadable value any time the Watchdog Strobe (WDS) bit is set to '1'. The counter is compared to the terminal value of '0'. If the counter reaches this value, it causes an internal flag and an optional interrupt output. You can prevent the time out interrupt by setting WDS bit to '1' prior to the counter reaching '0'. This causes the counter to reload with the watchdog time out value and to be restarted. As long as the user sets the WDS bit prior to the counter reaching the terminal value, the interrupt and WDT flag never occur.

New time out values are written by setting the watchdog write bit to '0'. When the WDW is '0', new writes to the watchdog time out value bits D5-D0 are enabled to modify the time out value. When WDW is '1', writes to bits D5-D0 are ignored. The WDW function enables a user to set the WDS bit without concern that the watchdog timer value is modified. A logical diagram of the watchdog timer is shown in [Figure 4](#). Note that setting the watchdog time out value to '0' disables the watchdog function.

The output of the watchdog timer is the flag bit WDF that is set if the watchdog is allowed to time out. The flag is set upon a watchdog time out and cleared when the user reads the Flags or Control registers. If the watchdog time out occurs, the user also enables an optional interrupt source to drive the INT pin.

Figure 4. Watchdog Timer Block Diagram

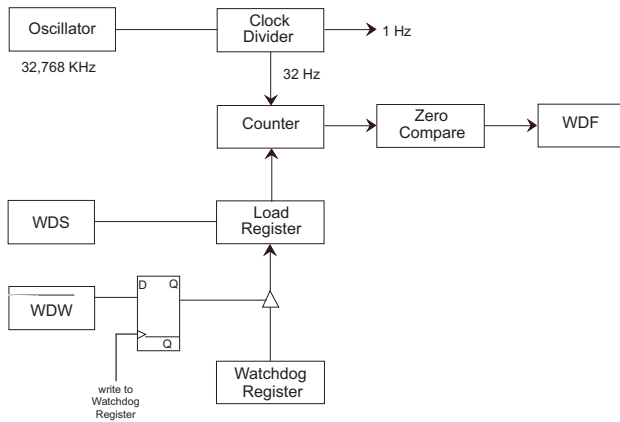

Power Monitor

The CY14B101K provides a power management scheme with power fail interrupt capability. It also controls the internal switch to backup power for the clock and protects the memory from low V_{CC} access. The power monitor is based on an internal band gap reference circuit that compares the V_{CC} voltage to V_{SWITCH} threshold.

As described in the “AutoStore® Operation” on page 4, when V_{SWITCH} is reached as V_{CC} decays from power loss, a data store operation is initiated from SRAM to the nonvolatile elements, securing the last SRAM data state. Power is also switched from V_{CC} to the backup supply (battery or capacitor) to operate the RTC oscillator.

When operating from the backup source, read and write operations to nvSRAM are inhibited and the clock functions are not available to the user. The clock continues to operate in the background. The updated clock data is available to the user $t_{HRECALL}$ delay after V_{CC} is restored to the device (see “AutoStore or Power Up RECALL” on page 20).

Interrupts

The CY14B101K has a Flags register, Interrupt register and Interrupt logic that can signal interrupt to the microcontroller. There are three potential sources for interrupt: watchdog timer, power monitor, and alarm timer. Each of these can be individually enabled to drive the INT pin by appropriate setting in the Interrupt register (0x1FFF6). In addition, each has an associated flag bit in the Flags register (0x1FFF0) that the host processor uses to determine the cause of the interrupt. The INT pin driver has two bits that specify its behavior when an interrupt occurs.

An Interrupt is raised only if both a flag is raised by one of the three sources and the respective interrupt enable bit in Interrupts register is enabled (set to ‘1’). After an interrupt source is active,

two programmable bits, H/L and P/L, determine the behavior of the output pin driver on INT pin. These two bits are located in the Interrupt register and can be used to drive level or pulse mode output from the INT pin. In pulse mode, the pulse width is internally fixed at approximately 200 ms. This mode is intended to reset a host microcontroller. In the level mode, the pin goes to its active polarity until the Flags register is read by the user. This mode is used as an interrupt to a host microcontroller. The control bits are summarized in the following section.

Interrupt Register

Watchdog Interrupt Enable - WIE. When set to ‘1’, the watchdog timer drives the INT pin and an internal flag when a watchdog time out occurs. When WIE is set to ‘0’, the watchdog timer only affects the WDF flag in Flags register.

Alarm Interrupt Enable - AIE. When set to ‘1’, the alarm match drives the INT pin and an internal flag. When AIE is set to ‘0’, the alarm match only affects the AF flag in Flags register.

Power Fail Interrupt Enable - PFE. When set to ‘1’, the power fail monitor drives the pin and an internal flag. When PFE is set to ‘0’, the power fail monitor only affects the PF flag in Flags register.

High/Low - H/L. When set to a ‘1’, the INT pin is active HIGH and the driver mode is push pull. The INT pin drives high only when V_{CC} is greater than V_{SWITCH} . When set to a ‘0’, the INT pin is active LOW and the drive mode is open drain. Active LOW (open drain) is operational even in battery backup mode.

Pulse/Level - P/L. When set to a ‘1’ and an interrupt occurs, the INT pin is driven for approximately 200 ms. When P/L is set to a ‘0’, the INT pin is driven high or low (determined by H/L) until the Flags or Control register is read.

When an enabled interrupt source activates the INT pin, an external host reads the Flags registers to determine the cause. Remember that all flags are cleared when the register is read. If the INT pin is programmed for Level mode, then the condition clears and the INT pin returns to its inactive state. If the pin is programmed for Pulse mode, then reading the flag also clears the flag and the pin. The pulse does not complete its specified duration if the Flags register is read. If the INT pin is used as a host reset, then the Flags or Control register is not read during a reset.

Flags Register

The Flag register has three flag bits: WDF, AF, and PF, which can be used to generate an interrupt. These flags are set by the watchdog timeout, alarm match, or power fail monitor respectively. The processor can either poll this register or enable interrupts to be informed when a flag is set. These flags are automatically reset once the register is read. The flags register is automatically loaded with the value 00h on power up (except for the OSCF bit. See “Stopping and Starting the Oscillator” on page 8.)

Figure 5. Interrupt Block Diagram

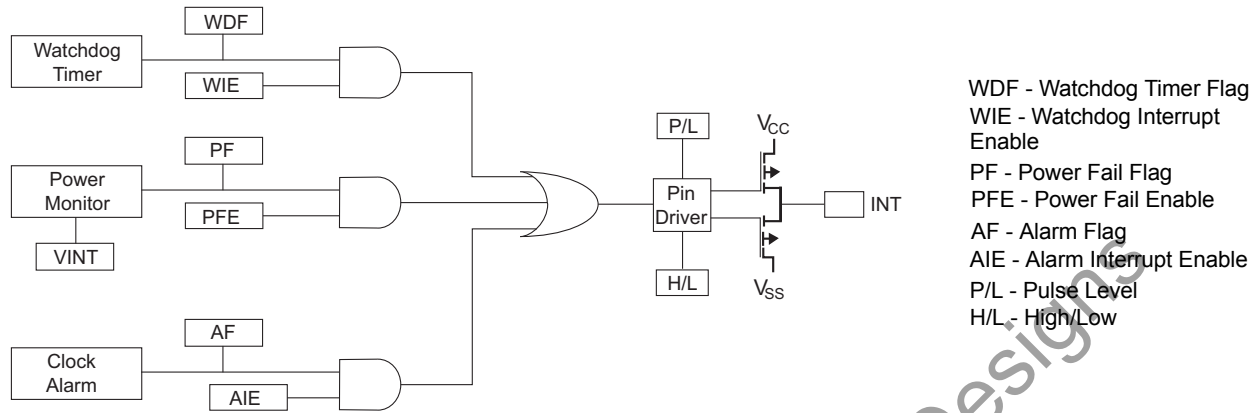
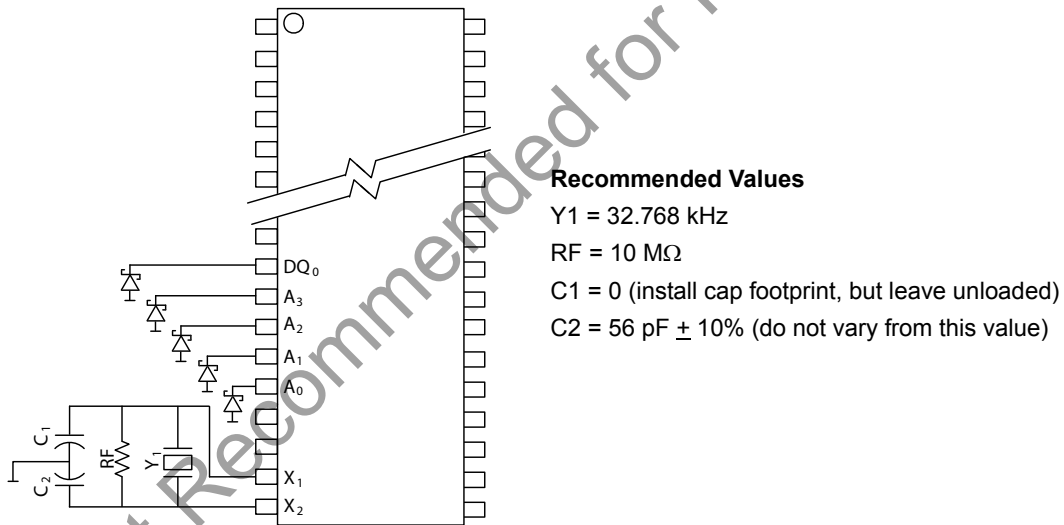

Figure 6. RTC Recommended Component Configuration



Note

4. Schottky diodes, ($V_F < 0.4V$ at $I_F=100$ mA) are recommended at pins $A_0 - A_3$ and DQ_0 in applications where undershoot exceeds $-0.5V$. Please see application note [AN49947](#) for further details.

Table 4. RTC Register Map^[5, 6]

Register	BCD Format Data ^[5]								Function/Range
	D7	D6	D5	D4	D3	D2	D1	D0	
0x1FFFF	10s Years				Years				Years: 00–99
0x1FFFE	0	0	0	10s Months	Months				Months: 01–12
0x1FFFD	0	0	10s Day of Month		Day Of Month				Day of Month: 01–31
0x1FFFC	0	0	0	0	0	Day of Week			Day of Week: 01–07
0x1FFFB	0	0	10s Hours		Hours				Hours: 00–23
0x1FFFA	0	10s Minutes			Minutes				Minutes: 00–59
0x1FFF9	0	10s Seconds			Seconds				Seconds: 00–59
0x1FFF8	OSCEN (0)	0	Cal Sign (0)	Calibration (00000)					Calibration Values ^[7]
0x1FFF7	WDS (0)	WDW (0)	WDT (000000)						Watchdog ^[7]
0x1FFF6	WIE (0)	AIE (0)	PFE (0)	0	H/L (1)	P/L (0)	0	0	Interrupts ^[7]
0x1FFF5	M (1)	0	10s Alarm Date		Alarm Day				Alarm, Day of Month: 01–31
0x1FFF4	M (1)	0	10s Alarm Hours		Alarm Hours				Alarm, Hours: 00–23
0x1FFF3	M (1)	10 Alarm Minutes			Alarm Minutes				Alarm, Minutes: 00–59
0x1FFF2	M (1)	10 Alarm Seconds			Alarm, Seconds				Alarm, Seconds: 00–59
0x1FFF1	10s Centuries				Centuries				Centuries: 00–99
0x1FFF0	WDF	AF	PF	OSCF	0	CAL (0)	W (0)	R (0)	Flags ^[7]

Notes

- 5. () designates values shipped from the factory.
- 6. The unused bits of RTC registers are reserved for future use and should be set to '0'.
- 7. Is a binary value, not a BCD value.

Table 5. Register Map Detail

0x1FFF	Time Keeping - Years							
	D7	D6	D5	D4	D3	D2	D1	D0
	10s Years				Years			
	Contains the lower two BCD digits of the year. Lower nibble (four bits) contains the value for years; upper nibble (four bits) contains the value for 10s of years. Each nibble operates from 0 to 9. The range for the register is 0–99.							
0x1FFE	Time Keeping - Months							
	D7	D6	D5	D4	D3	D2	D1	D0
	0	0	0	10s Month	Months			
	Contains the BCD digits of the month. Lower nibble (four bits) contains the lower digit and operates from 0 to 9; upper nibble (one bit) contains the upper digit and operates from 0 to 1. The range for the register is 1–12.							
0x1FFD	Time Keeping - Date							
	D7	D6	D5	D4	D3	D2	D1	D0
	0	0	10s Day of Month		Day of Month			
	Contains the BCD digits for the date of the month. Lower nibble (four bits) contains the lower digit and operates from 0 to 9; upper nibble (two bits) contains the 10s digit and operates from 0 to 3. The range for the register is 1–31. Leap years are automatically adjusted for.							
0x1FFC	Time Keeping - Day							
	D7	D6	D5	D4	D3	D2	D1	D0
	0	0	0	0	0	Day of Week		
	Lower nibble (three bits) contains a value that correlates to day of the week. Day of the week is a ring counter that counts from 1 to 7 then returns to 1. The user must assign meaning to the day value, because the day is not integrated with the date.							
0x1FFB	Time Keeping - Hours							
	D7	D6	D5	D4	D3	D2	D1	D0
	0	0	10s Hours		Hours			
	Contains the BCD value of hours in 24 hour format. Lower nibble (four bits) contains the lower digit and operates from 0 to 9; upper nibble (two bits) contains the upper digit and operates from 0 to 2. The range for the register is 0–23.							
0x1FFA	Time Keeping - Minutes							
	D7	D6	D5	D4	D3	D2	D1	D0
	0	10s Minutes			Minutes			
	Contains the BCD value of minutes. Lower nibble (four bits) contains the lower digit and operates from 0 to 9; upper nibble (three bits) contains the upper minutes digit and operates from 0 to 5. The range for the register is 0–59.							
0x1FF9	Time Keeping - Seconds							
	D7	D6	D5	D4	D3	D2	D1	D0
	0	10s Seconds			Seconds			
	Contains the BCD value of seconds. Lower nibble (four bits) contains the lower digit and operates from 0 to 9; upper nibble (three bits) contains the upper digit and operates from 0 to 5. The range for the register is 0–59.							

Table 5. Register Map Detail (continued)

0x1FFF8	Calibration/Control							
	D7	D6	D5	D4	D3	D2	D1	D0
	OSCEN	0	Calibration Sign	Calibration				
OSCEN	Oscillator Enable. When set to 1, the oscillator is stopped. When set to 0, the oscillator runs. Disabling the oscillator saves battery or capacitor power during storage.							
Calibration Sign	Determines if the calibration adjustment is applied as an addition (1) to or as a subtraction (0) from the time-base.							
Calibration	These five bits control the calibration of the clock.							
0x1FFF7	WatchDog Timer							
	D7	D6	D5	D4	D3	D2	D1	D0
	WDS	WDW	WDT					
WDS	Watchdog Strobe. Setting this bit to 1 reloads and restarts the watchdog timer. Setting the bit to 0 has no effect. The bit is cleared automatically after the watchdog timer is reset. The WDS bit is write only. Reading it always returns a 0.							
WDW	Watchdog Write Enable. Setting this bit to 1 disables any WRITE to the watchdog timeout value (D5–D0). This allows the user to set the watchdog strobe bit without disturbing the timeout value. Setting this bit to 0 allows bits D5–D0 to be written to the watchdog register when the next write cycle is complete. This function is explained in detail in the “Watchdog Timer” on page 9.							
WDT	Watchdog timeout selection. The watchdog timer interval is selected by the 6-bit value in this register. It represents a multiplier of the 32 Hz count (31.25 ms). The range of timeout value is 31.25 ms (a setting of 1) to 2 seconds (setting of 3 Fh). Setting the watchdog timer register to 0 disables the timer. These bits can be written only if the WDW bit was set to 0 on a previous cycle.							
0x1FFF6	Interrupt Status/Control							
	D7	D6	D5	D4	D3	D2	D1	D0
	WIE	AIE	PFIE	0	H/L	P/L	0	0
WIE	Watchdog Interrupt Enable. When set to 1 and a watchdog timeout occurs, the watchdog timer drives the INT pin and the WDF flag. When set to 0, the watchdog timeout affects only the WDF flag.							
AIE	Alarm Interrupt Enable. When set to 1, the alarm match drives the INT pin and the AF flag. When set to 0, the alarm match only affects the AF flag.							
PFIE	Power Fail Enable. When set to 1, the alarm match drives the INT pin and the PF flag. When set to 0, the power fail monitor affects only the PF flag.							
0	Reserved for future use							
H/L	High/Low. When set to 1, the INT pin is driven active HIGH. When set to 0, the INT pin is open drain, active LOW.							
P/L	Pulse/Level. When set to 1, the INT pin is driven active (determined by H/L) by an interrupt source for approximately 200 ms. When set to 0, the INT pin is driven to an active level (as set by H/L) until the flags register is read.							
0x1FFF5	Alarm - Day							
	D7	D6	D5	D4	D3	D2	D1	D0
	M	0	10s Alarm Date		Alarm Date			
	Contains the alarm value for the date of the month and the mask bit to select or deselect the date value.							
M	Match. When this bit is set to 0, the date value is used in the alarm match. Setting this bit to 1 causes the match circuit to ignore the date value.							

Table 5. Register Map Detail (continued)

		Alarm - Hours								
		D7	D6	D5	D4	D3	D2	D1	D0	
0x1FFF4	M	10s Alarm Hours				Alarm Hours				
	Contains the alarm value for the hours and the mask bit to select or deselect the hours value.									
M	Match. When this bit is set to 0, the hours value is used in the alarm match. Setting this bit to 1 causes the match circuit to ignore the hours value.									
		Alarm - Minutes								
		D7	D6	D5	D4	D3	D2	D1	D0	
0x1FFF3	M	10s Alarm Minutes				Alarm Minutes				
	Contains the alarm value for the minutes and the mask bit to select or deselect the minutes value.									
M	Match. When this bit is set to 0, the minutes value is used in the alarm match. Setting this bit to 1 causes the match circuit to ignore the minutes value.									
		Alarm - Seconds								
		D7	D6	D5	D4	D3	D2	D1	D0	
0x1FFF2	M	10s Alarm Seconds				Alarm Seconds				
	Contains the alarm value for the seconds and the mask bit to select or deselect the seconds' value.									
M	Match. When this bit is set to 0, the seconds value is used in the alarm match. Setting this bit to 1 causes the match circuit to ignore the seconds value.									
		Time Keeping - Centuries								
		D7	D6	D5	D4	D3	D2	D1	D0	
0x1FFF1		10s Centuries				Centuries				
	Contains the BCD value of centuries. Lower nibble contains the lower digit and operates from 0 to 9; upper nibble contains the upper digit and operates from 0 to 9. The range for the register is 0-99 centuries.									
		Flags								
		D7	D6	D5	D4	D3	D2	D1	D0	
0x1FFF0		WDF	AF	PF	OSCF	0	CAL	W	R	
	WDF	Watchdog Timer Flag. This read only bit is set to 1 when the watchdog timer is allowed to reach 0 without being reset by the user. It is cleared to 0 when the Flags register is read or on power-up.								
AF	Alarm Flag. This read only bit is set to 1 when the time and date match the values stored in the alarm registers with the match bits = 0. It is cleared when the Flags register is read or on power-up.									
PF	Power Fail Flag. This read only bit is set to 1 when power falls below the power fail threshold V_{SWITCH} . It is cleared to 0 when the Flags register is read or on power-up.									
OSCF	Oscillator Fail Flag. Set to 1 on power up if the oscillator is enabled and not running in the first 5 ms of operation. This indicates that RTC backup power failed and clock value is no longer valid. The user must reset this bit to 0 to clear this condition (Flag). The chip does not clear this flag. This bit survives power cycles.									
CAL	Calibration Mode. When set to 1, a 512 Hz square wave is output on the INT pin. When set to 0, the INT pin resumes normal operation. This bit defaults to 0 (disabled) on power up.									
W	Write Enable: Setting the W bit to 1 freezes updates of the RTC registers. The user can then write to RTC registers, Alarm registers, Calibration register, Interrupt register and Flags register. Setting the W bit to 0 causes the contents of the RTC registers to be transferred to the time keeping counters if the time has been changed (a new base time is loaded). This bit defaults to 0 on power up.									
R	Read Enable: Setting R bit to 1, stops clock updates to user RTC registers so that clock updates are not seen during the reading process. Set R bit to 0 to resume clock updates to the holding register. Setting this bit does not require W bit to be set to 1. This bit defaults to 0 on power up.									

Maximum Ratings

Exceeding maximum ratings may impair the useful life of the device. These user guidelines are not tested.

- Storage Temperature -65°C to +150°C
- Ambient Temperature with Power Applied -55°C to +125°C
- Supply Voltage on V_{CC} Relative to GND -0.5V to 4.1V
- Voltage Applied to Outputs in High Z State -0.5V to V_{CC} + 0.5V
- Input Voltage -0.5V to V_{CC} + 0.5V
- Transient Voltage (<20 ns) Any Pin to Ground Potential -2.0V to V_{CC} + 2.0V

- Package Power Dissipation Capability (T_A = 25°C) 1.0W
- Surface Mount Pb Soldering Temperature (3 Seconds) +260°C
- DC Output Current (1 output at a time, 1s duration) ... 15 mA
- Static Discharge Voltage > 2001V (MIL-STD-883, Method 3015)
- Latch Up Current > 200 mA

Operating Range

Range	Ambient Temperature	V _{CC}
Commercial	0°C to +70°C	2.7V to 3.6V
Industrial	-40°C to +85°C	

DC Electrical Characteristics

Over the Operating Range (V_{CC} = 2.7V to 3.6V) [8, 9]

Parameter	Description	Test Conditions	Min	Max	Unit
I _{CC1}	Average V _{CC} Current	t _{RC} = 25 ns Commercial		65	mA
		t _{RC} = 35 ns t _{RC} = 45 ns Dependent on output loading and cycle rate. Values obtained without output loads. I _{OUT} = 0 mA.	Industrial	55 50	
I _{CC2}	Average V _{CC} Current during STORE	All Inputs Do Not Care, V _{CC} = Max Average current for duration t _{STORE}		6	mA
I _{CC3}	Average V _{CC} Current at t _{AVAV} = 200 ns, 3V, 25°C Typical	$\overline{WE} \geq (V_{CC} - 0.2V)$. All other inputs cycling. Dependent on output loading and cycle rate. Values obtained without output loads.		10	mA
I _{CC4}	Average V _{CAP} Current during AutoStore Cycle	All Inputs Do Not Care, V _{CC} = Max Average current for duration t _{STORE}		3	mA
I _{SB}	V _{CC} Standby Current	$\overline{WE} \geq (V_{CC} - 0.2V)$. All others V _{IN} ≤ 0.2V or ≥ (V _{CC} - 0.2V). Standby current level after nonvolatile cycle is complete. Inputs are static. f = 0 MHz		3	mA
I _{IX}	Input Leakage Current	V _{CC} = Max, V _{SS} ≤ V _{IN} ≤ V _{CC}	-1	+1	μA
I _{OZ}	Off State Output Leakage Current	V _{CC} = Max, V _{SS} ≤ V _{IN} ≤ V _{CC} , \overline{CE} or $\overline{OE} \geq V_{IH}$	-1	+1	μA
V _{IH} [10]	Input HIGH Voltage		2.0	V _{CC} + 0.5	V
V _{IL}	Input LOW Voltage		V _{SS} - 0.5	0.8	V
V _{OH}	Output HIGH Voltage	I _{OUT} = -2 mA	2.4		V
V _{OL}	Output LOW Voltage	I _{OUT} = 4 mA		0.4	V
V _{CAP}	Storage Capacitor	Between V _{CAP} pin and V _{SS} , 5V rated	17	120	μF

Notes

- 8. The \overline{HSB} pin has I_{OUT} = -10 μA for V_{OH} of 2.4 V, this parameter is characterized but not tested.
- 9. The INT pin is open drain and does not source or sink current when interrupt register bit D3 is low.
- 10. V_{IH} changes by 100 mV when V_{CC} > 3.5V.

Data Retention and Endurance

Parameter	Description	Min	Unit
DATA _R	Data Retention	20	Years
NV _C	Nonvolatile STORE Operations	200	K

Capacitance

These parameters are guaranteed but not tested.

Parameter	Description	Test Conditions	Max	Unit
C _{IN}	Input Capacitance	T _A = 25°C, f = 1 MHz, V _{CC} = 0 to 3.0 V	7	pF
C _{OUT}	Output Capacitance		7	pF

Thermal Resistance

These parameters are guaranteed but not tested.

Parameter	Description	Test Conditions	48-SSOP	Unit
Θ _{JA}	Thermal Resistance (junction to ambient)	Test conditions follow standard test methods and procedures for measuring thermal impedance, in accordance with EIA/JESD51.	34.85	°C/W
Θ _{JC}	Thermal Resistance (junction to case)		16.35	°C/W

Figure 7. AC Test Loads

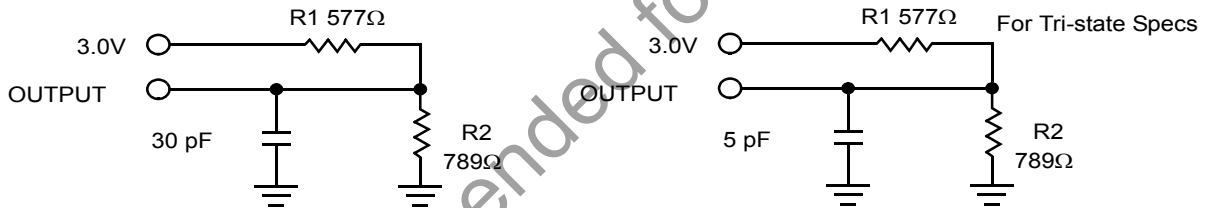

AC Test Conditions

Input Pulse Levels 0 V to 3 V
 Input Rise and Fall Times (10% - 90%) ≤5 ns
 Input and Output Timing Reference Levels 1.5 V

AC Switching Characteristics

Parameter		Description	25 ns		35 ns		45 ns		Unit
Cypress Parameter	Alt. Parameter		Min	Max	Min	Max	Min	Max	
SRAM Read Cycle									
t_{ACE}	t_{ELQV}	Chip Enable Access Time		25		35		45	ns
$t_{RC}^{[11]}$	t_{AVAV}, t_{ELEH}	Read Cycle Time	25		35		45		ns
$t_{AA}^{[12]}$	t_{AVQV}	Address Access Time		25		35		45	ns
t_{DOE}	t_{GLQV}	Output Enable to Data Valid		12		15		20	ns
$t_{OHA}^{[12]}$	t_{AXQX}	Output Hold After Address Change	3		3		3		ns
$t_{LZCE}^{[13]}$	t_{ELQX}	Chip Enable to Output Active	3		3		3		ns
$t_{HZCE}^{[13]}$	t_{EHQZ}	Chip Disable to Output Inactive		10		13		15	ns
$t_{LZOE}^{[13]}$	t_{GLQX}	Output Enable to Output Active	0		0		0		ns
$t_{HZOE}^{[13]}$	t_{GHQZ}	Output Disable to Output Inactive		10		13		15	ns
$t_{PU}^{[14]}$	t_{ELICCH}	Chip Enable to Power Active	0		0		0		ns
$t_{PD}^{[14]}$	t_{EHICCL}	Chip Disable to Power Standby		25		35		45	ns

Figure 8. SRAM Read Cycle 1: Address Controlled [11, 12, 15]

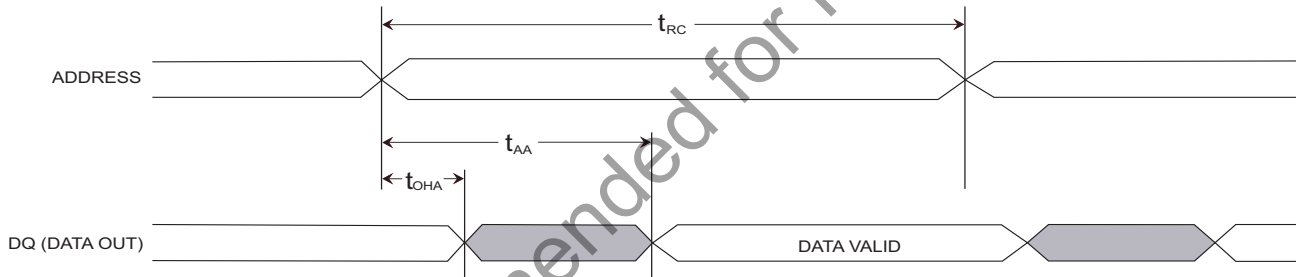
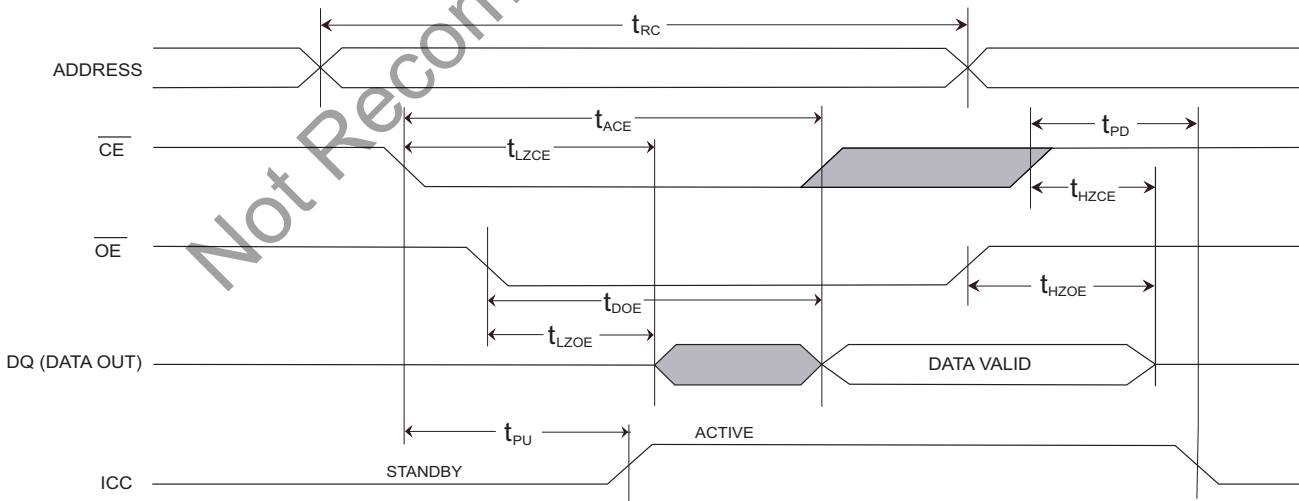

Figure 9. SRAM Read Cycle 2: \overline{CE} and \overline{OE} Controlled [11, 15]



Notes

- 11. WE is HIGH during SRAM Read Cycles.
- 12. Device is continuously selected with CE and OE both Low.
- 13. Measured ± 200 mV from steady state output voltage.
- 14. These parameters are guaranteed by design and are not tested.
- 15. HSB must remain HIGH during READ and WRITE cycles.

AC Switching Characteristics (continued)

Parameter		Description	25 ns		35 ns		45 ns		Unit
Cypress Parameter	Alt. Parameter		Min	Max	Min	Max	Min	Max	
SRAM Write Cycle									
t_{WC}	t_{AVAV}	Write Cycle Time	25		35		45		ns
t_{PWE}	t_{WLWH}, t_{WLEH}	Write Pulse Width	20		25		30		ns
t_{SCE}	t_{ELWH}, t_{ELEH}	Chip Enable To End of Write	20		25		30		ns
t_{SD}	t_{DVWH}, t_{DVEH}	Data Setup to End of Write	10		12		15		ns
t_{HD}	t_{WHDX}, t_{EHDX}	Data Hold After End of Write	0		0		0		ns
t_{AW}	t_{AVWH}, t_{AVEH}	Address Setup to End of Write	20		25		30		ns
t_{SA}	t_{AVWL}, t_{AVEL}	Address Setup to Start of Write	0		0		0		ns
t_{HA}	t_{WHAX}, t_{EHAX}	Address Hold After End of Write	0		0		0		ns
$t_{HZWE}^{[13, 16]}$	t_{WLQZ}	Write Enable to Output Disable		10		13		15	ns
$t_{LZWE}^{[13]}$	t_{WHQX}	Output Active After End of Write	3		3		3		ns

Figure 10. SRAM Write Cycle 1: \overline{WE} Controlled ^[15, 17]

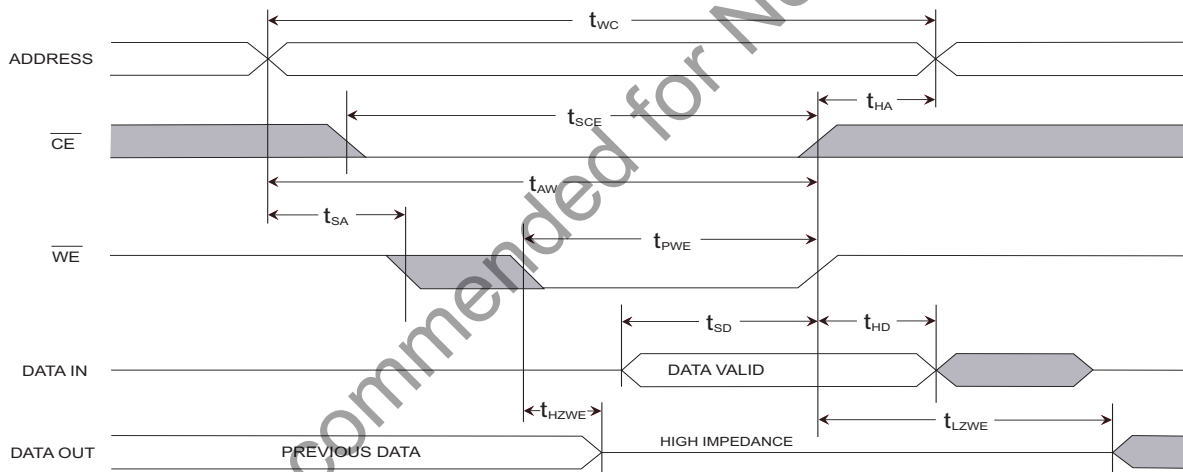
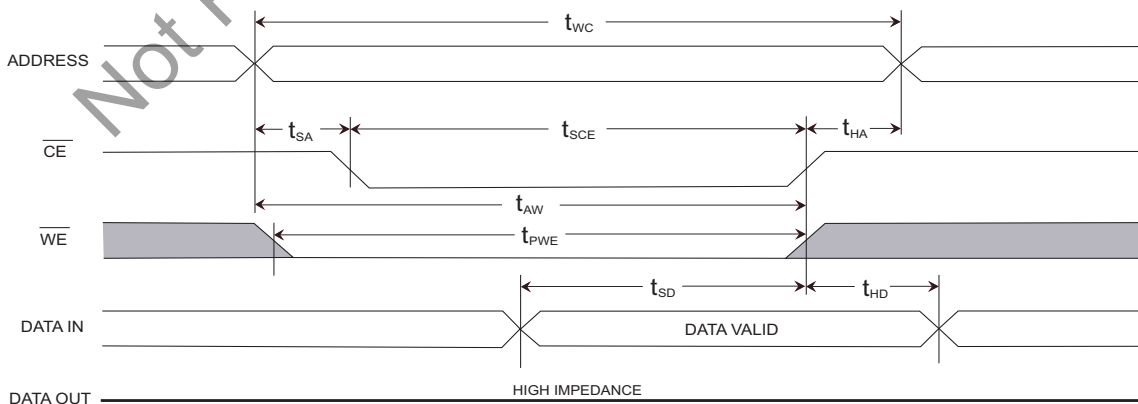

Figure 11. SRAM Write Cycle 2: \overline{CE} Controlled



Notes

- 16. If \overline{WE} is Low when \overline{CE} goes Low, the outputs remain in the High Impedance State.
- 17. \overline{CE} or \overline{WE} are greater than V_{IH} during address transitions.

AutoStore or Power Up RECALL

Parameter	Description	CY14B101K		Unit
		Min	Max	
$t_{HRECALL}^{[18]}$	Power Up RECALL Duration		40	ms
$t_{STORE}^{[19, 20]}$	STORE Cycle Duration	Commercial	12.5	ms
		Industrial	15	ms
V_{SWITCH}	Low Voltage Trigger Level		2.65	V
$t_{VCCRRISE}$	VCC Rise Time	150		μ S

Figure 12. AutoStore/Power Up RECALL

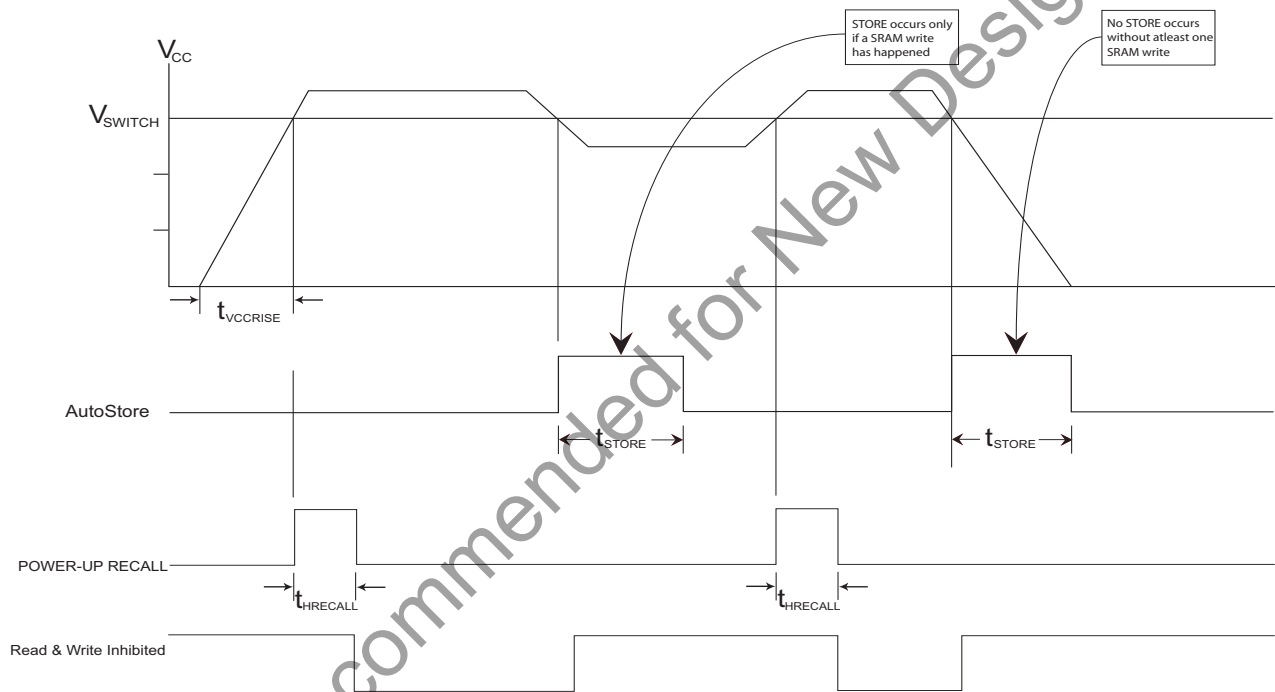

Notes

- 18. $t_{HRECALL}$ starts from the time V_{CC} rises above V_{SWITCH} .
- 19. If an SRAM Write does not taken place since the last nonvolatile cycle, no STORE takes place.
- 20. Industrial Grade Devices require 15 ms Max.

Software Controlled STORE/RECALL Cycles [21, 22]

Parameter	Alt. Parameter	Description	25 ns		35 ns		45 ns		Unit
			Min	Max	Min	Max	Min	Max	
t_{RC}	t_{AVAV}	STORE/RECALL Initiation Cycle Time	25		35		45		ns
t_{SA}	t_{AVEL}	Address Setup Time	0		0		0		ns
t_{CW}	t_{ELEH}	Clock Pulse Width	20		25		30		ns
t_{HA}	t_{EHAX}	Address Hold Time	1		1		1		ns
t_{RECALL}		RECALL Duration		170		170		170	μ s

Figure 13. \overline{CE} Controlled Software STORE/RECALL Cycle [22]

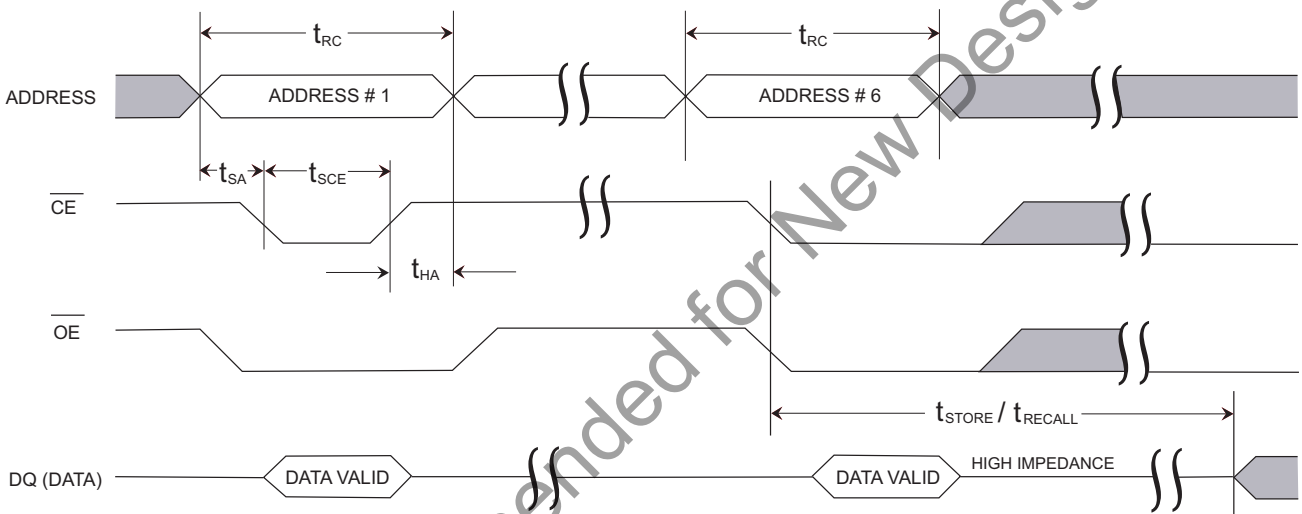
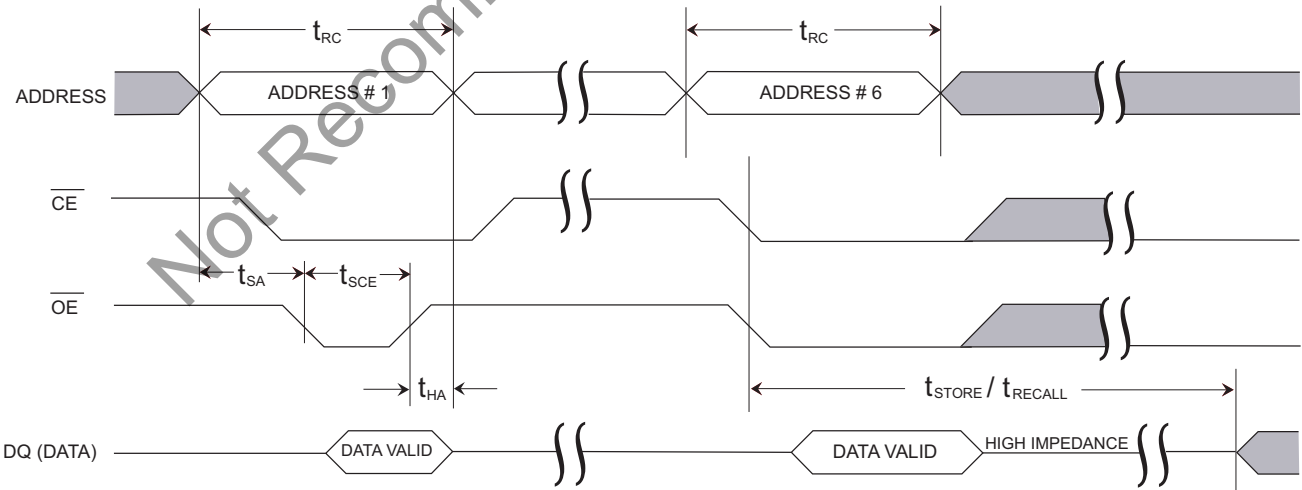

Figure 14. \overline{OE} Controlled Software STORE/RECALL Cycle [22]



Notes

- 21. The software sequence is clocked with \overline{CE} controlled or \overline{OE} controlled READs.
- 22. The six consecutive addresses are read in the order listed in the Table 2 on page 7. \overline{WE} is HIGH during all six consecutive cycles.

Hardware STORE Cycle

Parameter	Alt. Parameter	Description	CY14B101K		Unit
			Min	Max	
t_{DELAY} [25]		Time Allowed to Complete SRAM Cycle	1	70	μs
t_{PHSB}	t_{HLHX}	Hardware STORE Pulse Width	15		ns

Figure 15. Hardware STORE Cycle

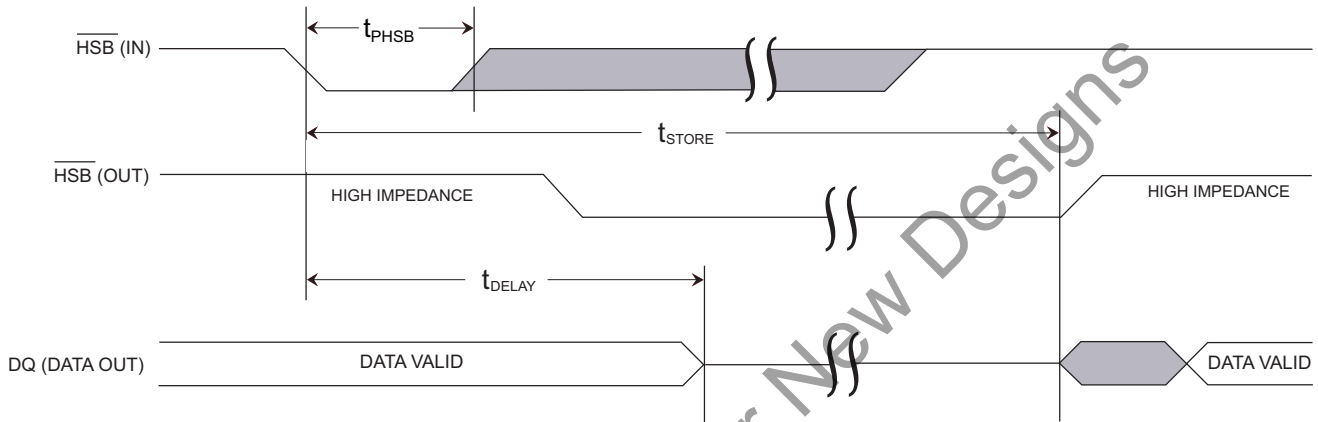

Soft Sequence Commands

Parameter	Description	CY14B101K		Unit
		Min	Max	
t_{SS} [22, 24]	Soft Sequence Processing Time		70	μs

Figure 16. Soft Sequence Processing [22, 24]

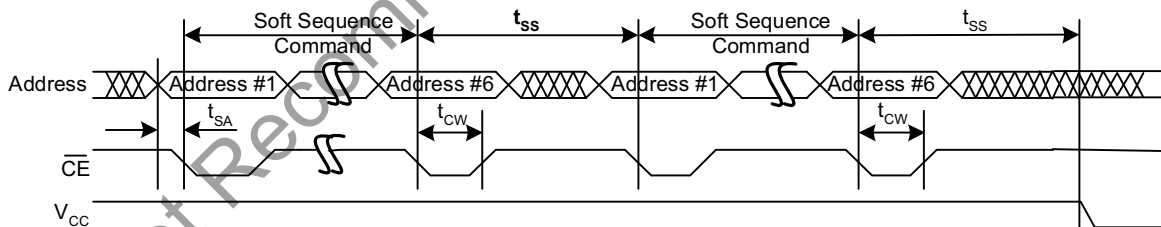

Notes

- 23. This is the amount of time it takes to take action on a soft sequence command. Vcc power must remain HIGH to effectively register command.
- 24. Commands such as STORE and RECALL lock out I/O until operation is complete which further increases this time. See specific command.
- 25. Read and Write cycles in progress before HSB are given this amount of time to complete.

RTC Characteristics

Parameter	Description	Test Conditions	Min	Max	Unit
I _{BAK} ^[26]	RTC Backup Current	Commercial		300	nA
		Industrial		350	nA
V _{RTCbat} ^[27]	RTC Battery Pin Voltage		1.8	3.3	V
V _{RTCcap} ^[28]	RTC Capacitor Pin Voltage		1.2	2.7	V
t _{OCS}	RTC Oscillator Time to Start	At Min Temperature from Power up or Enable		10	sec
		At 25°C Temperature from Power up or Enable		5	sec

Truth Table For SRAM Operations

$\overline{\text{HSB}}$ should remain HIGH for SRAM Operations.

CE	WE	OE	Inputs and Outputs	Mode	Power
H	X	X	High Z	Deselect/Power down	Standby
L	H	L	Data Out (DQ ₀ –DQ ₇);	Read	Active
L	H	H	High Z	Output Disabled	Active
L	L	X	Data in (DQ ₀ –DQ ₇);	Write	Active

Notes

26. From either V_{RTCcap} or V_{RTCbat}.
 27. Typical = 3.0V during normal operation.
 28. Typical = 2.4V during normal operation.

Part Numbering Nomenclature

CY 14 B 101 K - SP 25 X C T

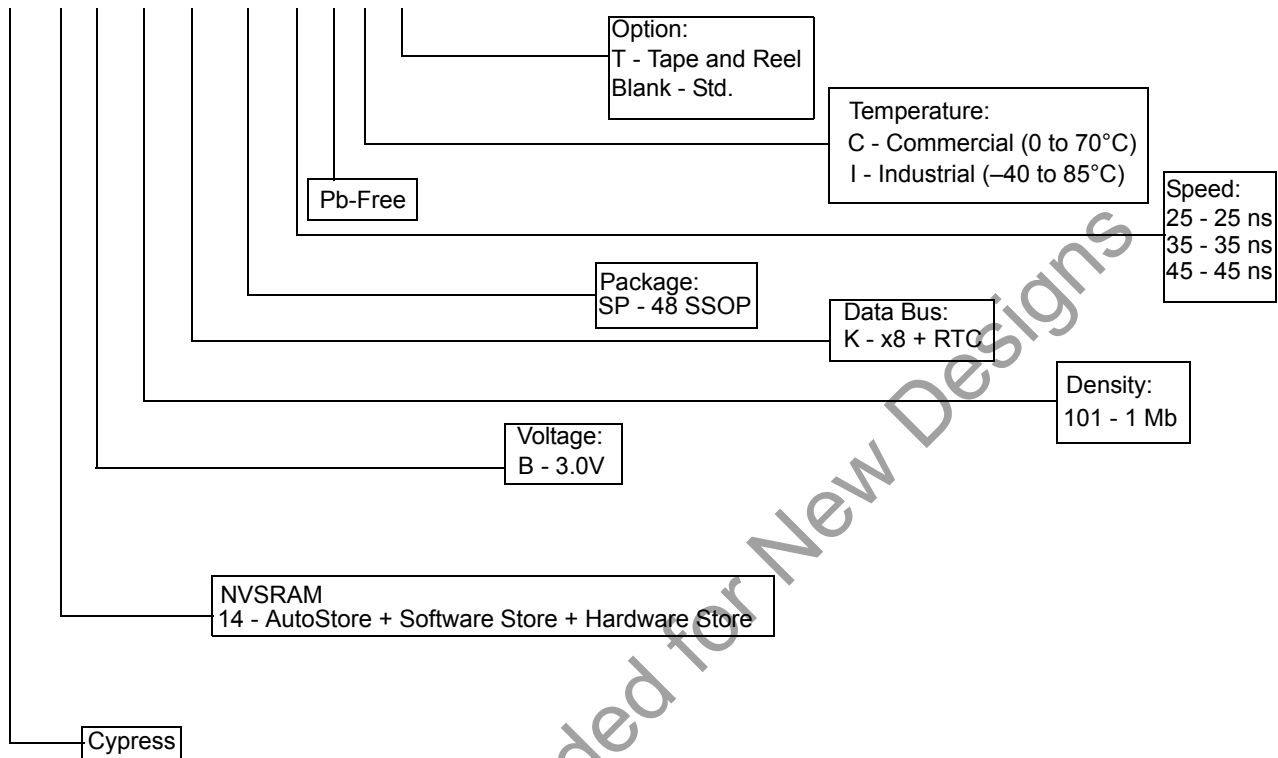

Not Recommended for New Designs

Ordering Information

These parts are not recommended for new designs.

Speed (ns)	Ordering Code	Package Diagram	Package Type	Operating Range
25	CY14B101K-SP25XC	51-85061	48-pin SSOP	Commercial
	CY14B101K-SP25XCT			
	CY14B101K-SP25XI	51-85061	48-pin SSOP	Industrial
	CY14B101K-SP25XIT			
35	CY14B101K-SP35XC	51-85061	48-pin SSOP	Commercial
	CY14B101K-SP35XCT			
	CY14B101K-SP35XI	51-85061	48-pin SSOP	Industrial
	CY14B101K-SP35XIT			
45	CY14B101K-SP45XC	51-85061	48-pin SSOP	Commercial
	CY14B101K-SP45XCT			
	CY14B101K-SP45XI	51-85061	48-pin SSOP	Industrial
	CY14B101K-SP45XIT			

All these parts are Pb-free. Contact your local Cypress sales representative for availability of these parts.

Not Recommended for New Designs