



Chipsmall Limited consists of a professional team with an average of over 10 year of expertise in the distribution of electronic components. Based in Hongkong, we have already established firm and mutual-benefit business relationships with customers from,Europe,America and south Asia,supplying obsolete and hard-to-find components to meet their specific needs.

With the principle of “Quality Parts,Customers Priority,Honest Operation,and Considerate Service”,our business mainly focus on the distribution of electronic components. Line cards we deal with include Microchip,ALPS,ROHM,Xilinx,Pulse,ON,Everlight and Freescale. Main products comprise IC,Modules,Potentiometer,IC Socket,Relay,Connector.Our parts cover such applications as commercial,industrial, and automotives areas.

We are looking forward to setting up business relationship with you and hope to provide you with the best service and solution. Let us make a better world for our industry!



## Contact us

Tel: +86-755-8981 8866 Fax: +86-755-8427 6832

Email & Skype: info@chipsmall.com Web: www.chipsmall.com

Address: A1208, Overseas Decoration Building, #122 Zhenhua RD., Futian, Shenzhen, China



## Clock Generator for Intel® Grantsdale Chipset

### Features

- Compliant with Intel® CK410
- Supports Intel P4 and Tejas CPU
- Selectable CPU frequencies
- Differential CPU clock pairs
- 100 MHz differential SRC clocks
- 96 MHz differential dot clock
- 48 MHz USB clocks
- 33 MHz PCI clock
- Low-voltage frequency select input
- I<sup>2</sup>C support with readback capabilities
- Ideal Lexmark Spread Spectrum profile for maximum electromagnetic interference (EMI) reduction
- 3.3V power supply
- 56-pin SSOP and TSSOP packages

CPU	SRC	PCI	REF	DOT96	USB_48
x2 / x3	x6 / x7	x 9	x 1	x 1	x 1

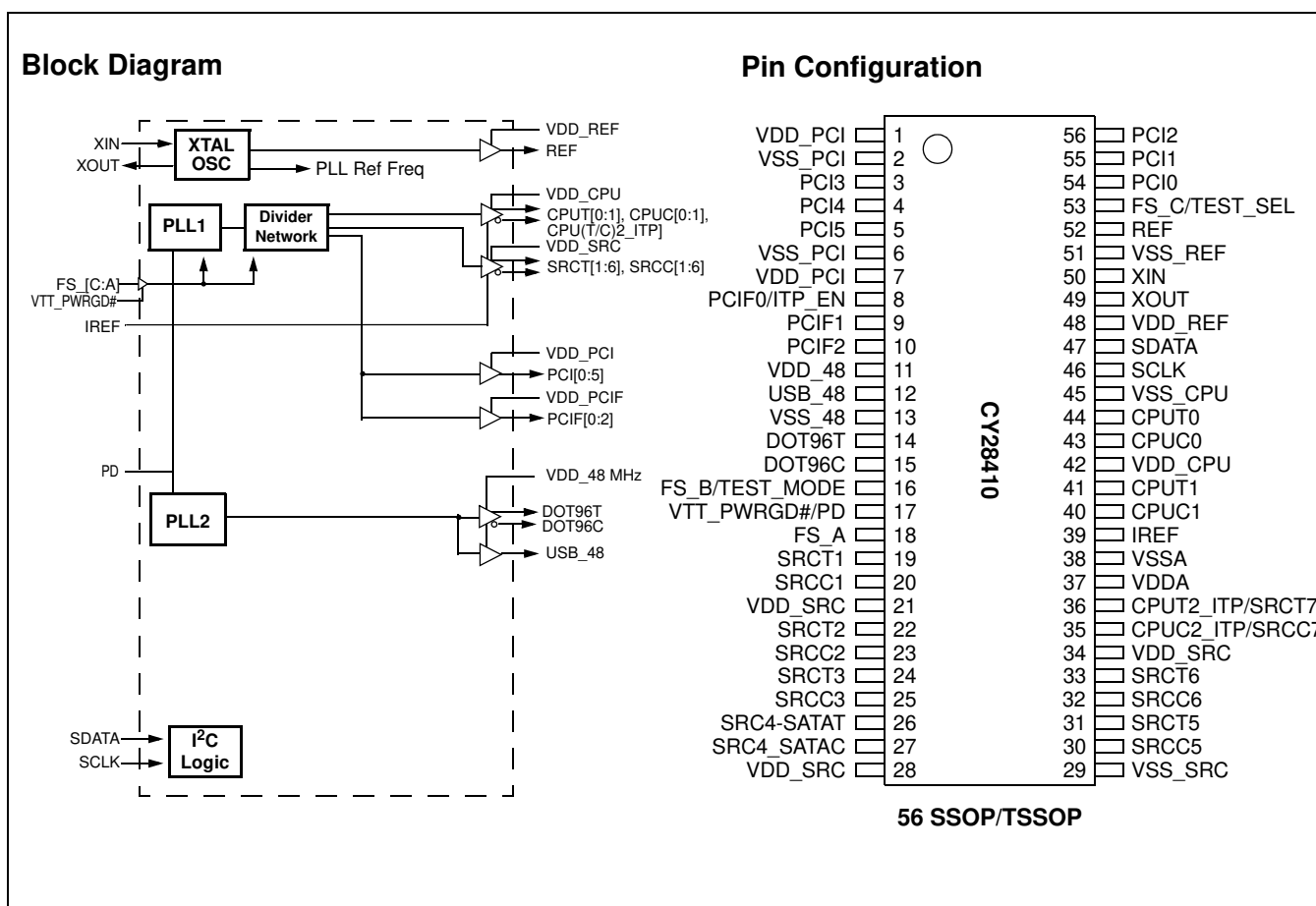

**Pin Definitions**

Pin No.	Name	Type	Description
44,43,41,40	CPUT/C	O, DIF	<b>Differential CPU clock outputs.</b>
36,35	CPUT2_ITP/SRCT7, CPUC2_ITP/SRCC7	O, DIF	<b>Selectable Differential CPU or SRC clock output.</b> ITP_EN = 0 @ VTT_PWRGD# assertion = SRC7 ITP_EN = 1 @ VTT_PWRGD# assertion = CPU2
14,15	DOT96T, DOT96C	O, DIF	<b>Fixed 96-MHz clock output.</b>
18	FS_A	I	<b>3.3V tolerant input for CPU frequency selection.</b> <i>Refer to DC Electrical Specifications table for Vil_FS and Vih_FS specifications.</i>
16	FS_B/TEST_MODE	I	<b>3.3V tolerant input for CPU frequency selection.</b> Selects Ref/N or Hi-Z when in test mode 0 = Hi-Z, 1 = Ref/N <i>Refer to DC Electrical Specifications table for Vil_FS and Vih_FS specifications.</i>
53	FS_C/TEST_SEL	I	<b>3.3V tolerant input for CPU frequency selection.</b> Selects test mode if pulled to VIHFS_C when VTT_PWRGD# is asserted low. <i>Refer to DC Electrical Specifications table for VILFS_C, VIMFS_C, VIHFS_C specifications.</i>
39	IREF	I	A Precision resistor is attached to this pin, which is connected to the internal current reference.
54,55,56,3,4,5	PCI	O, SE	<b>33-MHz clocks.</b>
9,10	PCIF	O, SE	<b>33-MHz clocks.</b>
8	PCIF0/ITP_EN	I/O, SE	<b>33-MHz clock/CPU2 select</b> (sampled on the VTT_PWRGD# assertion). 1 = CPU2_ITP, 0 = SRC7
52	REF	O, SE	<b>Reference clock.</b> 3.3V 14.318 MHz clock output.
46	SCLK	I	<b>SMBus-compatible SCLOCK.</b>
47	SDATA	I/O	<b>SMBus-compatible SDATA.</b>
26,27	SRC4_SATAT, SRC4_SATAC	O, DIF	<b>Differential serial reference clock.</b> recommended output for SATA.
19,20,22,23,24,25,31,30,33,32	SRCT/C	O, DIF	<b>Differential serial reference clocks.</b>
12	USB_48	I/O, SE	<b>Fixed 48 MHz clock output.</b>
11	VDD_48	PWR	<b>3.3V power supply for outputs.</b>
42	VDD_CPU	PWR	<b>3.3V power supply for outputs.</b>
1,7	VDD_PCI	PWR	<b>3.3V power supply for outputs.</b>
48	VDD_REF	PWR	<b>3.3V power supply for outputs.</b>
21,28,34	VDD_SRC	PWR	<b>3.3V power supply for outputs.</b>
37	VDDA	PWR	<b>3.3V power supply for PLL.</b>
13	VSS_48	GND	<b>Ground for outputs.</b>
45	VSS_CPU	GND	<b>Ground for outputs.</b>
2,6	VSS_PCI	GND	<b>Ground for outputs.</b>
51	VSS_REF	GND	<b>Ground for outputs.</b>
29	VSS_SRC	GND	<b>Ground for outputs.</b>
38	VSSA	GND	<b>Ground for PLL.</b>
17	VTT_PWRGD#/PD	I, PU	3.3V LVTTTL input is a level sensitive strobe used to latch the USB_48/FS_A, FS_B, FS_C/TEST_SEL and PCIF0/ITP_EN inputs. After VTT_PWRGD# (active low) assertion, this pin becomes a realtime input for asserting power-down (active high)
50	XIN	I	<b>14.318-MHz Crystal Input</b>
49	XOUT	O, SE	<b>14.318-MHz Crystal Output</b>

**Frequency Select Pins (FS\_A, FS\_B and FS\_C)**

Host clock frequency selection is achieved by applying the appropriate logic levels to FS\_A, FS\_B, FS\_C inputs prior to VTT\_PWRGD# assertion (as seen by the clock synthesizer). Upon VTT\_PWRGD# being sampled low by the clock chip (indicating processor VTT voltage is stable), the clock chip

samples the FS\_A, FS\_B and FS\_C input values. For all logic levels of FS\_A, FS\_B and FS\_C, VTT\_PWRGD# employs a one-shot functionality in that once a valid low on VTT\_PWRGD# has been sampled, all further VTT\_PWRGD#, FS\_A, FS\_B and FS\_C transitions will be ignored, except in test mode.

**Table 1. Frequency Select Table FS\_A, FS\_B and FS\_C**

FS_C	FS_B	FS_A	CPU	SRC	PCIF/PCI	REF0	DOT96	USB
MID	0	1	100 MHz	100 MHz	33 MHz	14.318 MHz	96 MHz	48 MHz
0	0	1	133 MHz	100 MHz	33 MHz	14.318 MHz	96 MHz	48 MHz
0	1	0	200 MHz	100 MHz	33 MHz	14.318 MHz	96 MHz	48 MHz
0	0	0	266 MHz	100 MHz	33 MHz	14.318 MHz	96 MHz	48 MHz
1	0	x	Hi-Z	Hi-Z	Hi-Z	Hi-Z	Hi-Z	Hi-Z
1	1	0	REF/2	REF/8	REF/24	REF	REF	REF
1	1	1	REF/2	REF/8	REF/24	REF	REF	REF

**Serial Data Interface**

To enhance the flexibility and function of the clock synthesizer, a two-signal serial interface is provided. Through the Serial Data Interface, various device functions, such as individual clock output buffers, can be individually enabled or disabled. The registers associated with the Serial Data Interface initialize to their default setting upon power-up, and therefore use of this interface is optional. Clock device register changes are normally made upon system initialization, if any are required. The interface cannot be used during system operation for power management functions.

**Data Protocol**

The clock driver serial protocol accepts byte write, byte read, block write, and block read operations from the controller. For block write/read operation, the bytes must be accessed in sequential order from lowest to highest byte (most significant bit first) with the ability to stop after any complete byte has been transferred. For byte write and byte read operations, the system controller can access individually indexed bytes. The offset of the indexed byte is encoded in the command code, as described in *Table 2*.

The block write and block read protocol is outlined in *Table 3* while *Table 4* outlines the corresponding byte write and byte read protocol. The slave receiver address is 11010010 (D2h).

**Table 2. Command Code Definition**

Bit	Description
7	0 = Block read or block write operation, 1 = Byte read or byte write operation
(6:0)	Byte offset for byte read or byte write operation. For block read or block write operations, these bits should be '0000000'

**Table 3. Block Read and Block Write Protocol**

Block Write Protocol		Block Read Protocol	
Bit	Description	Bit	Description
1	Start	1	Start
8:2	Slave address – 7 bits	8:2	Slave address – 7 bits
9	Write	9	Write
10	Acknowledge from slave	10	Acknowledge from slave
18:11	Command Code – 8 bits	18:11	Command Code – 8 bits
19	Acknowledge from slave	19	Acknowledge from slave
27:20	Byte Count – 8 bits (Skip this step if I <sup>2</sup> C_EN bit set)	20	Repeat start
28	Acknowledge from slave	27:21	Slave address – 7 bits
36:29	Data byte 1 – 8 bits	28	Read = 1
37	Acknowledge from slave	29	Acknowledge from slave
45:38	Data byte 2 – 8 bits	37:30	Byte Count from slave – 8 bits

**Table 3. Block Read and Block Write Protocol (continued)**

Block Write Protocol		Block Read Protocol	
Bit	Description	Bit	Description
46	Acknowledge from slave	38	Acknowledge
....	Data Byte /Slave Acknowledges	46:39	Data byte 1 from slave – 8 bits
....	Data Byte N –8 bits	47	Acknowledge
....	Acknowledge from slave	55:48	Data byte 2 from slave – 8 bits
....	Stop	56	Acknowledge
		....	Data bytes from slave / Acknowledge
		....	Data Byte N from slave – 8 bits
		....	NOT Acknowledge
		....	Stop

**Table 4. Byte Read and Byte Write Protocol**

Byte Write Protocol		Byte Read Protocol	
Bit	Description	Bit	Description
1	Start	1	Start
8:2	Slave address – 7 bits	8:2	Slave address – 7 bits
9	Write	9	Write
10	Acknowledge from slave	10	Acknowledge from slave
18:11	Command Code – 8 bits	18:11	Command Code – 8 bits
19	Acknowledge from slave	19	Acknowledge from slave
27:20	Data byte – 8 bits	20	Repeated start
28	Acknowledge from slave	27:21	Slave address – 7 bits
29	Stop	28	Read
		29	Acknowledge from slave
		37:30	Data from slave – 8 bits
		38	NOT Acknowledge
		39	Stop

**Control Registers**

**Byte 0:Control Register 0**

Bit	@Pup	Name	Description
7	1	CPUT2_ITP/SRCT7 CPUC2_ITP/SRCC7	CPU[T/C]2_ITP/SRC[T/C]7 Output Enable 0 = Disable (Hi-Z), 1 = Enable
6	1	SRC[T/C]6	SRC[T/C]6 Output Enable 0 = Disable (Hi-Z), 1 = Enable
5	1	SRC[T/C]5	SRC[T/C]5 Output Enable 0 = Disable (Hi-Z), 1 = Enable
4	1	SRC[T/C]4	SRC[T/C]4 Output Enable 0 = Disable (Hi-Z), 1 = Enable
3	1	SRC[T/C]3	SRC[T/C]3 Output Enable 0 = Disable (Hi-Z), 1 = Enable
2	1	SRC[T/C]2	SRC[T/C]2 Output Enable 0 = Disable (Hi-Z), 1 = Enable
1	1	SRC[T/C]1	SRC[T/C]1 Output Enable 0 = Disable (Hi-Z), 1 = Enable
0	1	Reserved	Reserved, Set = 1

**Byte 1: Control Register 1**

Bit	@Pup	Name	Description
7	1	PCIF0	PCIF0 Output Enable 0 = Disabled, 1 = Enabled
6	1	DOT_96T/C	DOT_96 MHz Output Enable 0 = Disable (Hi-Z), 1 = Enabled
5	1	USB_48	USB_48 MHz Output Enable 0 = Disabled, 1 = Enabled
4	1	REF	REF Output Enable 0 = Disabled, 1 = Enabled
3	0	Reserved	Reserved
2	1	CPU[T/C]1	CPU[T/C]1 Output Enable 0 = Disable (Hi-Z), 1 = Enabled
1	1	CPU[T/C]0	CPU[T/C]0 Output Enable 0 = Disable (Hi-Z), 1 = Enabled
0	0	CPU[T/C] SRCT/C PCIF PCI	Spread Spectrum Enable 0 = Spread off, 1 = Spread on

**Byte 2: Control Register 2**

Bit	@Pup	Name	Description
7	1	PCI5	PCI5 Output Enable 0 = Disabled, 1 = Enabled
6	1	PCI4	PCI4 Output Enable 0 = Disabled, 1 = Enabled
5	1	PCI3	PCI3 Output Enable 0 = Disabled, 1 = Enabled
4	1	PCI2	PCI2 Output Enable 0 = Disabled, 1 = Enabled
3	1	PCI1	PCI1 Output Enable 0 = Disabled, 1 = Enabled
2	1	PCI0	PCI0 Output Enable 0 = Disabled, 1 = Enabled
1	1	PCIF2	PCIF2 Output Enable 0 = Disabled, 1 = Enabled
0	1	PCIF1	PCIF1 Output Enable 0 = Disabled, 1 = Enabled

**Byte 3: Control Register 3**

Bit	@Pup	Name	Description
7	0	SRC7	Allow control of SRC[T/C]7 with assertion of SW PCI_STP# 0 = Free running, 1 = Stopped with SW PCI_STP#
6	0	SRC6	Allow control of SRC[T/C]6 with assertion of SW PCI_STP# 0 = Free running, 1 = Stopped with SW PCI_STP#
5	0	SRC5	Allow control of SRC[T/C]5 with assertion of SW PCI_STP# 0 = Free running, 1 = Stopped with SW PCI_STP#
4	0	SRC4	Allow control of SRC[T/C]4 with assertion of SW PCI_STP# 0 = Free running, 1 = Stopped with SW PCI_STP#
3	0	SRC3	Allow control of SRC[T/C]3 with assertion of SW PCI_STP# 0 = Free running, 1 = Stopped with SW PCI_STP#
2	0	SRC2	Allow control of SRC[T/C]2 with assertion of SW PCI_STP# 0 = Free running, 1 = Stopped with SW PCI_STP#

**Byte 3: Control Register 3** (continued)

Bit	@Pup	Name	Description
1	0	SRC1	Allow control of SRC[T/C]1 with assertion of SW PCI_STP# 0 = Free running, 1 = Stopped with SW PCI_STP#
0	0	Reserved	Reserved, Set = 0

**Byte 4: Control Register 4**

Bit	@Pup	Name	Description
7	0	Reserved	Reserved, Set = 0
6	0	DOT96[T/C]	DOT_PWRDWN Drive Mode 0 = Driven in PWRDWN, 1 = Hi-Z
5	0	PCIF2	Allow control of PCIF2 with assertion of SW PCI_STP# 0 = Free running, 1 = Stopped with SW PCI_STP#
4	0	PCIF1	Allow control of PCIF1 with assertion of SW PCI_STP# 0 = Free running, 1 = Stopped with SW PCI_STP#
3	0	PCIF0	Allow control of PCIF0 with assertion of SW PCI_STP# 0 = Free running, 1 = Stopped with SW PCI_STP#
2	1	Reserved	Reserved, Set = 1
1	1	Reserved	Reserved, Set = 1
0	1	Reserved	Reserved, Set = 1

**Byte 5: Control Register 5**

Bit	@Pup	Name	Description
7	0	SRC[T/C][7:0]	SRC[T/C] Stop Drive Mode 0 = Driven when SW PCI_STP# asserted, 1 = Hi-Z when PCI_STP# asserted
6	0	Reserved	Reserved, Set = 0
5	0	Reserved	Reserved, Set = 0
4	0	Reserved	Reserved, Set = 0
3	0	SRC[T/C][7:0]	SRC[T/C] PWRDWN Drive Mode 0 = Driven when PD asserted, 1 = Hi-Z when PD asserted
2	0	CPU[T/C]2	CPU[T/C]2 PWRDWN Drive Mode 0 = Driven when PD asserted, 1 = Hi-Z when PD asserted
1	0	CPU[T/C]1	CPU[T/C]1 PWRDWN Drive Mode 0 = Driven when PD asserted, 1 = Hi-Z when PD asserted
0	0	CPU[T/C]0	CPU[T/C]0 PWRDWN Drive Mode 0 = Driven when PD asserted, 1 = Hi-Z when PD asserted

**Byte 6: Control Register 6**

Bit	@Pup	Name	Description
7	0		REF/N or Hi-Z Select 1 = REF/N Clock, 0 = Hi-Z
6	0		Test Clock Mode Entry Control 1 = REF/N or Hi-Z mode, 0 = Normal operation
5	0	Reserved	Reserved, Set = 0
4	1	REF	REF Output Drive Strength 0 = Low, 1 = High
3	1	PCIF, SRC, PCI	SW PCI_STP# Function 0=SW PCI_STP assert, 1 = SW PCI_STP deassert When this bit is set to 0, all STOPPABLE PCI, PCIF and SRC outputs will be stopped in a synchronous manner with no short pulses. When this bit is set to 1, all STOPPED PCI, PCIF and SRC outputs will resume in a synchronous manner with no short pulses.

**Byte 6: Control Register 6 (continued)**

Bit	@Pup	Name	Description
2	Externally selected	CPUT/C	FS_C. Reflects the value of the FS_C pin sampled on power-up 0 = FS_C was low during VTT_PWRGD# assertion
1	Externally selected	CPUT/C	FS_B. Reflects the value of the FS_B pin sampled on power-up 0 = FS_B was low during VTT_PWRGD# assertion
0	Externally selected	CPUT/C	FS_A. Reflects the value of the FS_A pin sampled on power-up 0 = FS_A was low during VTT_PWRGD# assertion

**Byte 7: Vendor ID**

Bit	@Pup	Name	Description
7	0	Revision Code Bit 3	Revision Code Bit 3
6	0	Revision Code Bit 2	Revision Code Bit 2
5	1	Revision Code Bit 1	Revision Code Bit 1
4	0	Revision Code Bit 0	Revision Code Bit 0
3	1	Vendor ID Bit 3	Vendor ID Bit 3
2	0	Vendor ID Bit 2	Vendor ID Bit 2
1	0	Vendor ID Bit 1	Vendor ID Bit 1
0	0	Vendor ID Bit 0	Vendor ID Bit 0

**Crystal Recommendations**

The CY28410 requires a Parallel Resonance Crystal. Substituting a series resonance crystal will cause the CY28410 to operate at the wrong frequency and violate the ppm specification. For most applications there is a 300ppm frequency shift between series and parallel crystals due to incorrect loading.

**Crystal Loading**

Crystal loading plays a critical role in achieving low ppm performance. To realize low ppm performance, the total capacitance the crystal will see must be considered to calculate the appropriate capacitive loading (CL).

The following diagram shows a typical crystal configuration using the two trim capacitors. An important clarification for the following discussion is that the trim capacitors are in series with the crystal not parallel. It's a common misconception that load capacitors are in parallel with the crystal and should be approximately equal to the load capacitance of the crystal. This is not true.

**Table 5. Crystal Recommendations**

Frequency (Fund)	Cut	Loading	Load Cap	Drive (max.)	Shunt Cap (max.)	Motional (max.)	Tolerance (max.)	Stability (max.)	Aging (max.)
14.31818 MHz	AT	Parallel	20 pF	0.1 mW	5 pF	0.016 pF	35 ppm	30 ppm	5 ppm



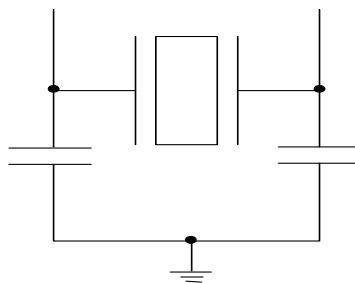

Figure 1. Crystal Capacitive Clarification

### Calculating Load Capacitors

In addition to the standard external trim capacitors, trace capacitance and pin capacitance must also be considered to correctly calculate crystal loading. As mentioned previously, the capacitance on each side of the crystal is in series with the crystal. This means the total capacitance on each side of the crystal must be twice the specified crystal load capacitance (CL). While the capacitance on each side of the crystal is in series with the crystal, trim capacitors (Ce1,Ce2) should be calculated to provide equal capacitive loading on both sides.

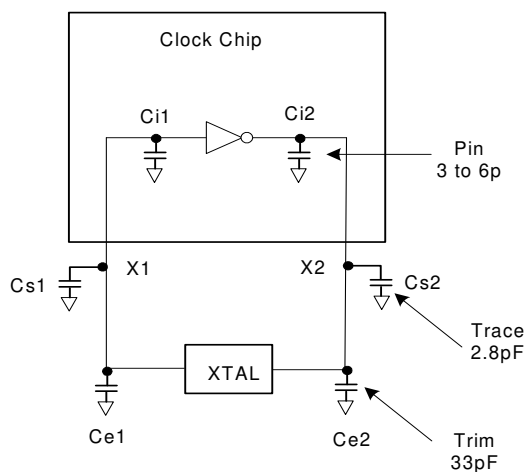

Figure 2. Crystal Loading Example

As mentioned previously, the capacitance on each side of the crystal is in series with the crystal. This means the total capacitance on each side of the crystal must be twice the specified load capacitance (CL). While the capacitance on each side of the crystal is in series with the crystal, trim capacitors (Ce1,Ce2) should be calculated to provide equal capacitance loading on both sides.

Use the following formulas to calculate the trim capacitor values from Ce1 and Ce2.

**Load Capacitance (each side)**

$$C_e = 2 * CL - (C_s + C_i)$$

**Total Capacitance (as seen by the crystal)**

$$CL_e = \frac{1}{\left( \frac{1}{C_{e1} + C_{s1} + C_{i1}} + \frac{1}{C_{e2} + C_{s2} + C_{i2}} \right)}$$

- CL ..... Crystal load capacitance
- CLe ..... Actual loading seen by crystal using standard value trim capacitors
- Ce ..... External trim capacitors
- Cs ..... Stray capacitance (terraced)
- Ci ..... Internal capacitance (lead frame, bond wires etc.)

**PD (Power-down) Clarification**

The VTT\_PWRGD# /PD pin is a dual function pin. During initial power-up, the pin functions as VTT\_PWRGD#. Once VTT\_PWRGD# has been sampled low by the clock chip, the pin assumes PD functionality. The PD pin is an asynchronous active high input used to shut off all clocks cleanly prior to shutting off power to the device. This signal is synchronized internal to the device prior to powering down the clock synthesizer. PD is also an asynchronous input for powering up the system. When PD is asserted high, all clocks are driven to a low value and held prior to turning off the VCOs and the crystal oscillator.

**PD (Power-down) – Assertion**

When PD is sampled high by two consecutive rising edges of CPUC, all single-ended outputs will be held low on their next high to low transition and differential clocks must be held high or Hi-Z (depending on the state of the control register drive

mode bit) on the next diff clock# high to low transition within 4 clock periods. When the SMBus PD drive mode bit corresponding to the differential (CPU, SRC, and DOT) clock output of interest is programmed to '0', the clock output must be held with "Diff clock" pin driven high at 2 x Iref, and "Diff clock#" tristate. If the control register PD drive mode bit corresponding to the output of interest is programmed to "1", then both the "Diff clock" and the "Diff clock#" are Hi-Z. Note the example below shows CPUT = 133 MHz and PD drive mode = '1' for all differential outputs. This diagram and description is applicable to valid CPU frequencies 100,133,166,200,266,333, and 400 MHz. In the event that PD mode is desired as the initial power-on state, PD must be asserted high in less than 10 uS after asserting VTT\_PWRGD#.

**PD Deassertion**

The power-up latency is less than 1.8 ms. This is the time from the deassertion of the PD pin or the ramping of the power supply until the time that stable clocks are output from the clock chip. All differential outputs stopped in a three-state condition resulting from power-down must be driven high in less than 300 uS of PD deassertion to a voltage greater than 200 mV. After the clock chip's internal PLL is powered up and locked, all outputs are enabled within a few clock cycles of each other. Below is an example showing the relationship of clocks coming up.

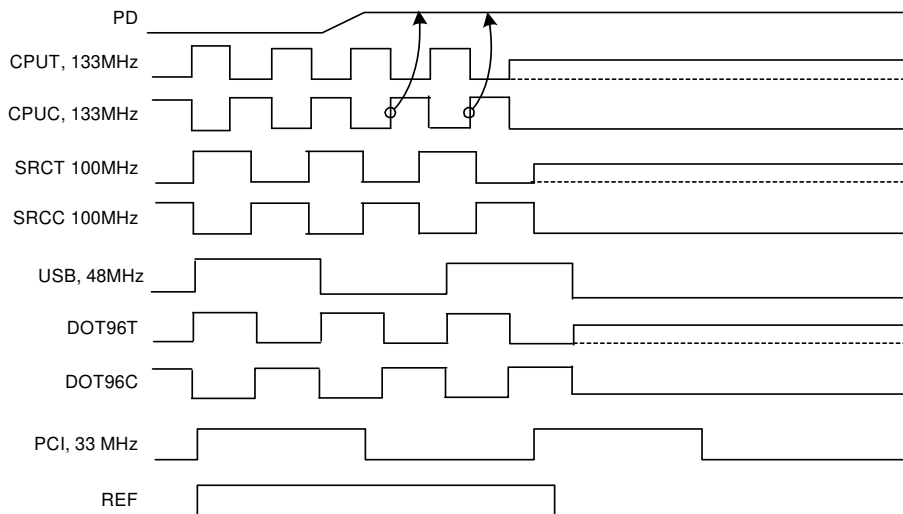

**Figure 3. Power-down Assertion Timing Waveform**

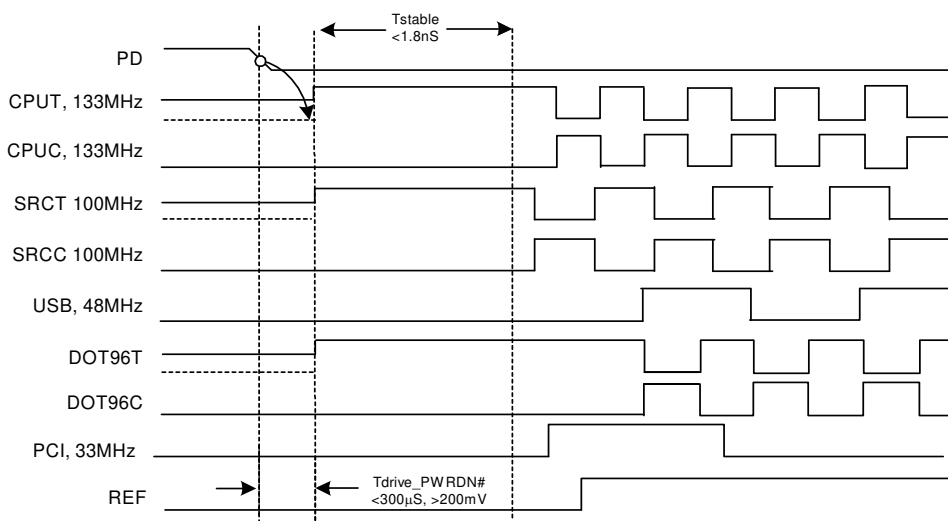

Figure 4. Power-down Deassertion Timing Waveform

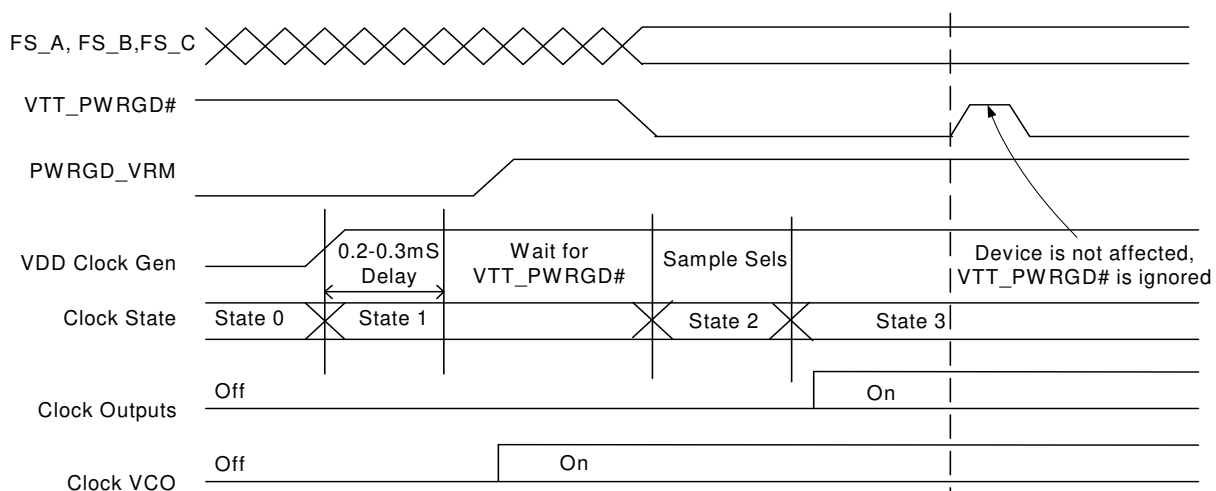

Figure 5. VTT\_PWRGD# Timing Diagram

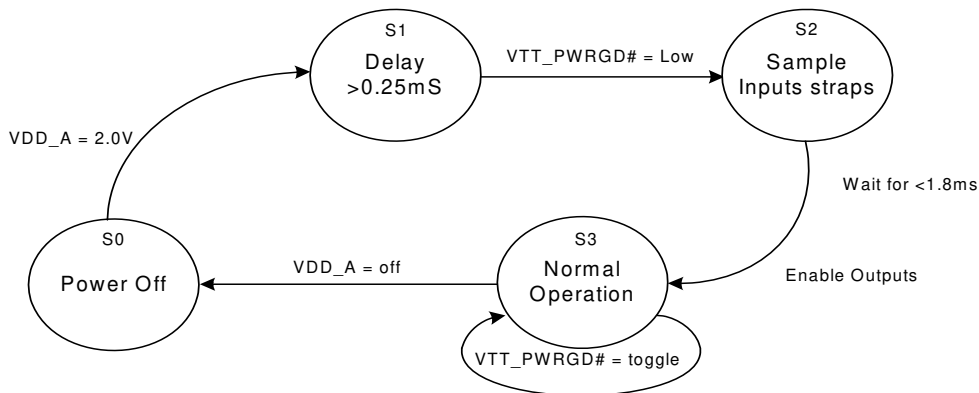

Figure 6. Clock Generator Power-up/Run State Diagram

### Absolute Maximum Conditions

Parameter	Description	Condition	Min.	Max.	Unit
V <sub>DD</sub>	Core Supply Voltage		-0.5	4.6	V
V <sub>DD_A</sub>	Analog Supply Voltage		-0.5	4.6	V
V <sub>IN</sub>	Input Voltage	Relative to V <sub>SS</sub>	-0.5	V <sub>DD</sub> + 0.5	VDC
T <sub>S</sub>	Temperature, Storage	Non-functional	-65	150	°C
T <sub>A</sub>	Temperature, Operating Ambient	Functional	0	70	°C
T <sub>J</sub>	Temperature, Junction	Functional	-	150	°C
∅ <sub>JC</sub>	Dissipation, Junction to Case (Mil-Spec 883E Method 1012.1)	SSOP	39.56		°C/W
		TSSOP	20.62		
∅ <sub>JA</sub>	Dissipation, Junction to Ambient JEDEC (JESD 51)	SSOP	45.29		°C/W
		TSSOP	62.26		
ESD <sub>HBM</sub>	ESD Protection (Human Body Model)	MIL-STD-883, Method 3015	2000	-	V
UL-94	Flammability Rating	At 1/8 in.	V-0		
MSL	Moisture Sensitivity Level		1		

**Multiple Supplies:** The voltage on any input or I/O pin cannot exceed the power pin during power-up. Power supply sequencing is NOT required.

### DC Electrical Specifications

Parameter	Description	Condition	Min.	Max.	Unit
V <sub>DD_A</sub> V <sub>DD_REF</sub> , V <sub>DD_PCI</sub> , V <sub>DD_3V66</sub> , V <sub>DD_48</sub> , V <sub>DD_CPU</sub>	3.3V Operating Voltage	3.3 ± 5%	3.135	3.465	V
V <sub>IL2C</sub>	Input Low Voltage	SDATA, SCLK	-	1.0	V
V <sub>IH2C</sub>	Input High Voltage	SDATA, SCLK	2.2	-	V
V <sub>IL_FS</sub>	FS_A/FS_B Input Low Voltage		V <sub>SS</sub> - 0.3	0.35	V
V <sub>IH_FS</sub>	FS_A/FS_B Input High Voltage		0.7	V <sub>DD</sub> + 0.5	V
V <sub>ILFS_C</sub>	FS_C Low Range		0	0.35	V
V <sub>IMFS_C</sub>	FS_C Mid Range		0.7	1.7	V
V <sub>IHFS_C</sub>	FS_C High Range		2.1	V <sub>DD</sub>	V
V <sub>IL</sub>	Input Low Voltage		V <sub>SS</sub> - 0.5	0.8	V
V <sub>IH</sub>	Input High Voltage		2.0	V <sub>DD</sub> + 0.5	V
I <sub>IL</sub>	Input Low Leakage Current	except internal pull-up resistors, 0 < V <sub>IN</sub> < V <sub>DD</sub>	-5		μA
I <sub>IH</sub>	Input High Leakage Current	except internal pull-down resistors, 0 < V <sub>IN</sub> < V <sub>DD</sub>		5	μA
V <sub>OL</sub>	Output Low Voltage	I <sub>OL</sub> = 1 mA	-	0.4	V
V <sub>OH</sub>	Output High Voltage	I <sub>OH</sub> = -1 mA	2.4	-	V
I <sub>OZ</sub>	High-impedance Output Current		-10	10	μA
C <sub>IN</sub>	Input Pin Capacitance		2	5	pF
C <sub>OUT</sub>	Output Pin Capacitance		3	6	pF
L <sub>IN</sub>	Pin Inductance		-	7	nH
V <sub>XIH</sub>	Xin High Voltage		0.7V <sub>DD</sub>	V <sub>DD</sub>	V
V <sub>XIL</sub>	Xin Low Voltage		0	0.3V <sub>DD</sub>	V
I <sub>DD3.3V</sub>	Dynamic Supply Current	At max load and freq per Figure 8	-	550	mA
I <sub>PD3.3V</sub>	Power-down Supply Current	PD asserted, Outputs driven	-	70	mA



**DC Electrical Specifications** (continued)

Parameter	Description	Condition	Min.	Max.	Unit
I <sub>PD3.3V</sub>	Power-down Supply Current	PD asserted, Outputs Hi-Z	–	2	mA

**AC Electrical Specifications**

Parameter	Description	Condition	Min.	Max.	Unit
<b>Crystal</b>					
T <sub>DC</sub>	XIN Duty Cycle	The device will operate reliably with input duty cycles up to 30/70 but the REF clock duty cycle will not be within specification	47.5	52.5	%
T <sub>PERIOD</sub>	XIN Period	When XIN is driven from an external clock source	69.841	71.0	ns
T <sub>R</sub> / T <sub>F</sub>	XIN Rise and Fall Times	Measured between 0.3V <sub>DD</sub> and 0.7V <sub>DD</sub>	–	10.0	ns
T <sub>CCJ</sub>	XIN Cycle to Cycle Jitter	As an average over 1- $\mu$ s duration	–	500	ps
L <sub>ACC</sub>	Long-term Accuracy	Over 150 ms	–	300	ppm
<b>CPU at 0.7V</b>					
T <sub>DC</sub>	CPUT and CPUC Duty Cycle	Measured at crossing point V <sub>OX</sub>	43	57	%
T <sub>PERIOD</sub>	100-MHz CPUT and CPUC Period	Measured at crossing point V <sub>OX</sub>	9.997001	10.00300	ns
T <sub>PERIOD</sub>	133-MHz CPUT and CPUC Period	Measured at crossing point V <sub>OX</sub>	7.497751	7.502251	ns
T <sub>PERIOD</sub>	200-MHz CPUT and CPUC Period	Measured at crossing point V <sub>OX</sub>	4.998500	5.001500	ns
T <sub>PERIOD</sub>	266-MHz CPUT and CPUC Period	Measured at crossing point V <sub>OX</sub>	3.748875	3.751125	ns
T <sub>PERIODSS</sub>	100-MHz CPUT and CPUC Period, SSC	Measured at crossing point V <sub>OX</sub>	9.997001	10.05327	ns
T <sub>PERIODSS</sub>	133-MHz CPUT and CPUC Period, SSC	Measured at crossing point V <sub>OX</sub>	7.497751	7.539950	ns
T <sub>PERIODSS</sub>	200-MHz CPUT and CPUC Period, SSC	Measured at crossing point V <sub>OX</sub>	4.998500	5.026634	ns
T <sub>PERIODSS</sub>	266-MHz CPUT and CPUC Period, SSC	Measured at crossing point V <sub>OX</sub>	3.748875	3.769975	ns
T <sub>PERIODAbs</sub>	100-MHz CPUT and CPUC Absolute period	Measured at crossing point V <sub>OX</sub>	9.912001	10.08800	ns
T <sub>PERIODAbs</sub>	133-MHz CPUT and CPUC Absolute period	Measured at crossing point V <sub>OX</sub>	7.412751	7.587251	ns
T <sub>PERIODSSAbs</sub>	100-MHz CPUT and CPUC Absolute period, SSC	Measured at crossing point V <sub>OX</sub>	9.912001	10.13827	ns
T <sub>PERIODSSAbs</sub>	133-MHz CPUT and CPUC Absolute period, SSC	Measured at crossing point V <sub>OX</sub>	7.412751	7.624950	ns
T <sub>PERIODSSAbs</sub>	200-MHz CPUT and CPUC Absolute period, SSC	Measured at crossing point V <sub>OX</sub>	4.913500	5.111634	ns
T <sub>PERIODSSAbs</sub>	266-MHz CPUT and CPUC Absolute period, SSC	Measured at crossing point V <sub>OX</sub>	3.663875	3.854975	ns
T <sub>PERIODSSAbs</sub>	400-MHz CPUT and CPUC Absolute period, SSC	Measured at crossing point V <sub>OX</sub>	2.414250	2.598317	ns
T <sub>SKEW</sub>	Any CPUT/C to CPUT/C Clock Skew, SSC	Measured at crossing point V <sub>OX</sub>	–	100	ps
T <sub>CCJ2</sub>	CPU2_ITP Cycle to Cycle Jitter	Measured at crossing point V <sub>OX</sub>	–	125	ps
T <sub>CCJ</sub>	CPUT/C Cycle to Cycle Jitter	Measured at crossing point V <sub>OX</sub>	–	115	ps
T <sub>SKEW2</sub>	CPU2_ITP to CPU0 Clock Skew	Measured at crossing point V <sub>OX</sub>	–	150	ps
T <sub>R</sub> / T <sub>F</sub>	CPUT and CPUC Rise and Fall Times	Measured from V <sub>OL</sub> = 0.175 to V <sub>OH</sub> = 0.525V	175	1100	ps



AC Electrical Specifications (continued)

Parameter	Description	Condition	Min.	Max.	Unit
T <sub>RFM</sub>	Rise/Fall Matching	Determined as a fraction of $2*(T_R - T_F)/(T_R + T_F)$	-	20	%
ΔT <sub>R</sub>	Rise Time Variation		-	125	ps
ΔT <sub>F</sub>	Fall Time Variation		-	125	ps
V <sub>HIGH</sub>	Voltage High	Math averages <i>Figure 8</i>	660	850	mV
V <sub>LOW</sub>	Voltage Low	Math averages <i>Figure 8</i>	-150	-	mV
V <sub>OX</sub>	Crossing Point Voltage at 0.7V Swing		250	550	mV
V <sub>OVS</sub>	Maximum Overshoot Voltage		-	V <sub>HIGH</sub> + 0.3	V
V <sub>UDS</sub>	Minimum Undershoot Voltage		-0.3	-	V
V <sub>RB</sub>	Ring Back Voltage	See <i>Figure 8</i> . Measure SE	-	0.2	V
<b>SRC</b>					
T <sub>DC</sub>	SRCT and SRCC Duty Cycle	Measured at crossing point V <sub>OX</sub>	45	55	%
T <sub>PERIOD</sub>	100-MHz SRCT and SRCC Period	Measured at crossing point V <sub>OX</sub>	9.997001	10.00300	ns
T <sub>PERIODSS</sub>	100-MHz SRCT and SRCC Period, SSC	Measured at crossing point V <sub>OX</sub>	9.997001	10.05327	ns
T <sub>PERIODAbs</sub>	100-MHz SRCT and SRCC Absolute Period	Measured at crossing point V <sub>OX</sub>	10.12800	9.872001	ns
T <sub>PERIODSSAbs</sub>	100-MHz SRCT and SRCC Absolute Period, SSC	Measured at crossing point V <sub>OX</sub>	9.872001	10.17827	ns
T <sub>SKEW</sub>	SRC Skew	Measured at crossing point V <sub>OX</sub>	-	250	ps
T <sub>CCJ</sub>	SRCT/C Cycle to Cycle Jitter	Measured at crossing point V <sub>OX</sub>	-	125	ps
L <sub>ACC</sub>	SRCT/C Long Term Accuracy	Measured at crossing point V <sub>OX</sub>	-	300	ppm
T <sub>R</sub> / T <sub>F</sub>	SRCT and SRCC Rise and Fall Times	Measured from V <sub>OL</sub> = 0.175 to V <sub>OH</sub> = 0.525V	175	1100	ps
T <sub>RFM</sub>	Rise/Fall Matching	Determined as a fraction of $2*(T_R - T_F)/(T_R + T_F)$	-	20	%
ΔT <sub>R</sub>	Rise Time Variation		-	125	ps
ΔT <sub>F</sub>	Fall Time Variation		-	125	ps
V <sub>HIGH</sub>	Voltage High	Math averages <i>Figure 8</i>	660	850	mV
V <sub>LOW</sub>	Voltage Low	Math averages <i>Figure 8</i>	-150	-	mV
V <sub>OX</sub>	Crossing Point Voltage at 0.7V Swing		250	550	mV
V <sub>OVS</sub>	Maximum Overshoot Voltage		-	V <sub>HIGH</sub> + 0.3	V
V <sub>UDS</sub>	Minimum Undershoot Voltage		-0.3	-	V
V <sub>RB</sub>	Ring Back Voltage	See <i>Figure 8</i> . Measure SE	-	0.2	V
<b>PCI/PCIF</b>					
T <sub>DC</sub>	PCI Duty Cycle	Measurement at 1.5V	45	55	%
T <sub>PERIOD</sub>	Spread Disabled PCIF/PCI Period	Measurement at 1.5V	29.99100	30.00900	ns
T <sub>PERIODSS</sub>	Spread Enabled PCIF/PCI Period, SSC	Measurement at 1.5V	29.9910	30.15980	ns
T <sub>PERIODAbs</sub>	Spread Disabled PCIF/PCI Period	Measurement at 1.5V	29.49100	30.50900	ns
T <sub>PERIODSSAbs</sub>	Spread Enabled PCIF/PCI Period, SSC	Measurement at 1.5V	29.49100	30.65980	ns
T <sub>HIGH</sub>	PCIF and PCI high time	Measurement at 2.4V	11.5	-	ns
T <sub>LOW</sub>	PCIF and PCI low time	Measurement at 0.4V	11.5	-	ns
T <sub>R</sub> / T <sub>F</sub>	PCIF and PCI rise and fall times	Measured between 0.8V and 2.0V	0.5	2.0	ns



AC Electrical Specifications (continued)

Parameter	Description	Condition	Min.	Max.	Unit
T <sub>SKEW</sub>	Any PCI clock to Any PCI clock Skew	Measurement at 1.5V	–	500	ps
T <sub>CCJ</sub>	PCIF and PCI Cycle to Cycle Jitter	Measurement at 1.5V	–	500	ps
<b>DOT</b>					
T <sub>DC</sub>	DOT96T and DOT96C Duty Cycle	Measured at crossing point V <sub>OX</sub>	45	55	%
T <sub>PERIOD</sub>	DOT96T and DOT96C Period	Measured at crossing point V <sub>OX</sub>	10.41354	10.41979	ns
T <sub>PERIODAbs</sub>	DOT96T and DOT96C Absolute Period	Measured at crossing point V <sub>OX</sub>	10.16354	10.66979	ns
T <sub>CCJ</sub>	DOT96T/C Cycle to Cycle Jitter	Measured at crossing point V <sub>OX</sub>	–	250	ps
L <sub>ACC</sub>	DOT96T/C Long Term Accuracy	Measured at crossing point V <sub>OX</sub>	–	100	ppm
T <sub>R</sub> / T <sub>F</sub>	DOT96T and DOT96C Rise and Fall Times	Measured from V <sub>OL</sub> = 0.175 to V <sub>OH</sub> = 0.525V	175	1100	ps
T <sub>RFM</sub>	Rise/Fall Matching	Determined as a fraction of 2*(T <sub>R</sub> – T <sub>F</sub> )/(T <sub>R</sub> + T <sub>F</sub> )	–	20	%
ΔT <sub>R</sub>	Rise Time Variation		–	125	ps
ΔT <sub>F</sub>	Fall Time Variation		–	125	ps
V <sub>HIGH</sub>	Voltage High	Math averages <i>Figure 8</i>	660	850	mV
V <sub>LOW</sub>	Voltage Low	Math averages <i>Figure 8</i>	–150	–	mV
V <sub>OX</sub>	Crossing Point Voltage at 0.7V Swing		250	550	mV
V <sub>OVS</sub>	Maximum Overshoot Voltage		–	V <sub>HIGH</sub> + 0.3	V
V <sub>UDS</sub>	Minimum Undershoot Voltage		–0.3	–	V
V <sub>RB</sub>	Ring Back Voltage	See <i>Figure 8</i> . Measure SE	–	0.2	V
<b>USB</b>					
T <sub>DC</sub>	Duty Cycle	Measurement at 1.5V	45	55	%
T <sub>PERIOD</sub>	Period	Measurement at 1.5V	20.83125	20.83542	ns
T <sub>PERIODAbs</sub>	Absolute Period	Measurement at 1.5V	20.48125	21.18542	ns
T <sub>HIGH</sub>	USB high time	Measurement at 2.4V	8.094	10.036	ns
T <sub>LOW</sub>	USB low time	Measurement at 0.4V	7.694	9.836	ns
T <sub>R</sub> / T <sub>F</sub>	Rise and Fall Times	Measured between 0.8V and 2.0V	0.475	1.4	ns
T <sub>CCJ</sub>	Cycle to Cycle Jitter	Measurement at 1.5V	–	350	ps
L <sub>ACC</sub>	USB Long Term Accuracy		–	100	ppm
<b>REF</b>					
T <sub>DC</sub>	REF Duty Cycle	Measurement at 1.5V	45	55	%
T <sub>PERIOD</sub>	REF Period	Measurement at 1.5V	69.8203	69.8622	ns
T <sub>PERIODAbs</sub>	REF Absolute Period	Measurement at 1.5V	68.82033	70.86224	ns
T <sub>R</sub> / T <sub>F</sub>	REF Rise and Fall Times	Measured between 0.8V and 2.0V	0.35	2.0	V/ns
T <sub>CCJ</sub>	REF Cycle to Cycle Jitter	Measurement at 1.5V	–	1000	ps
<b>ENABLE/DISABLE and SET-UP</b>					
T <sub>STABLE</sub>	Clock Stabilization from Power-up		–	1.8	ms
T <sub>SS</sub>	Stopclock Set-up Time		10.0	–	ns
T <sub>SH</sub>	Stopclock Hold Time		0	–	ns

**Test and Measurement Set-up**

**For PCI Single-ended Signals and Reference**

The following diagram shows the test load configurations for the single-ended PCI, USB, and REF output signals.

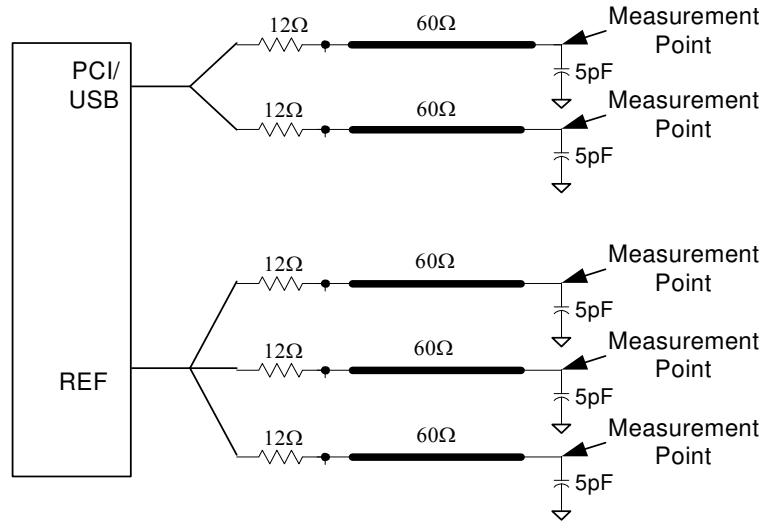

**Figure 7. Single-ended Load Configuration**

**For Differential CPU, SRC and DOT96 Output Signals**

The following diagram shows the test load configuration for the differential CPU and SRC outputs.

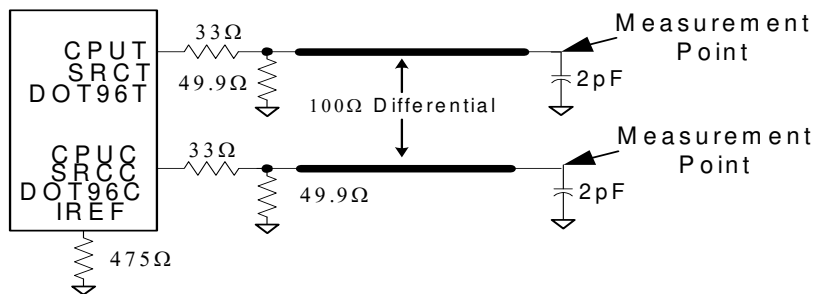

**Figure 8. 0.7V Single-ended Load Configuration**

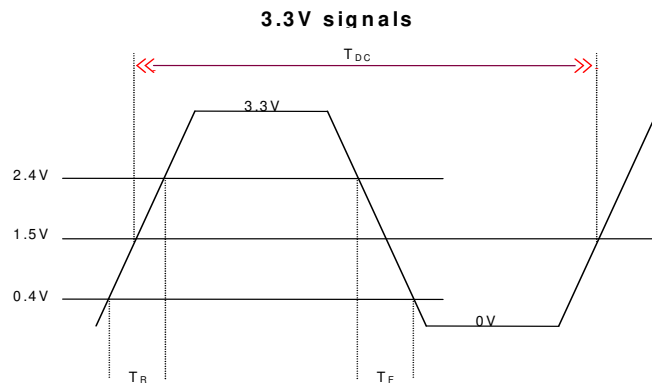

**Figure 9. Single-ended Output Signals (for AC Parameters Measurement)**



**Ordering Information**

Part Number	Package Type	Product Flow
<b>Standard</b>		
CY28410OC	56-pin SSOP	Commercial, 0° to 70°C
CY28410OCT	56-pin SSOP – Tape and Reel	Commercial, 0° to 70°C
CY28410ZC	56-pin TSSOP	Commercial, 0° to 70°C
CY28410ZCT	56-pin TSSOP – Tape and Reel	Commercial, 0° to 70°C
<b>Lead-free (Planned)</b>		
CY28410OXC	56-pin SSOP	Commercial, 0° to 70°C
CY28410OXCT	56-pin SSOP – Tape and Reel	Commercial, 0° to 70°C
CY28410ZXC	56-pin TSSOP	Commercial, 0° to 70°C
CY28410ZXCT	56-pin TSSOP – Tape and Reel	Commercial, 0° to 70°C

**Package Drawing and Dimensions**

**56-lead Shrunk Small Outline Package O56**

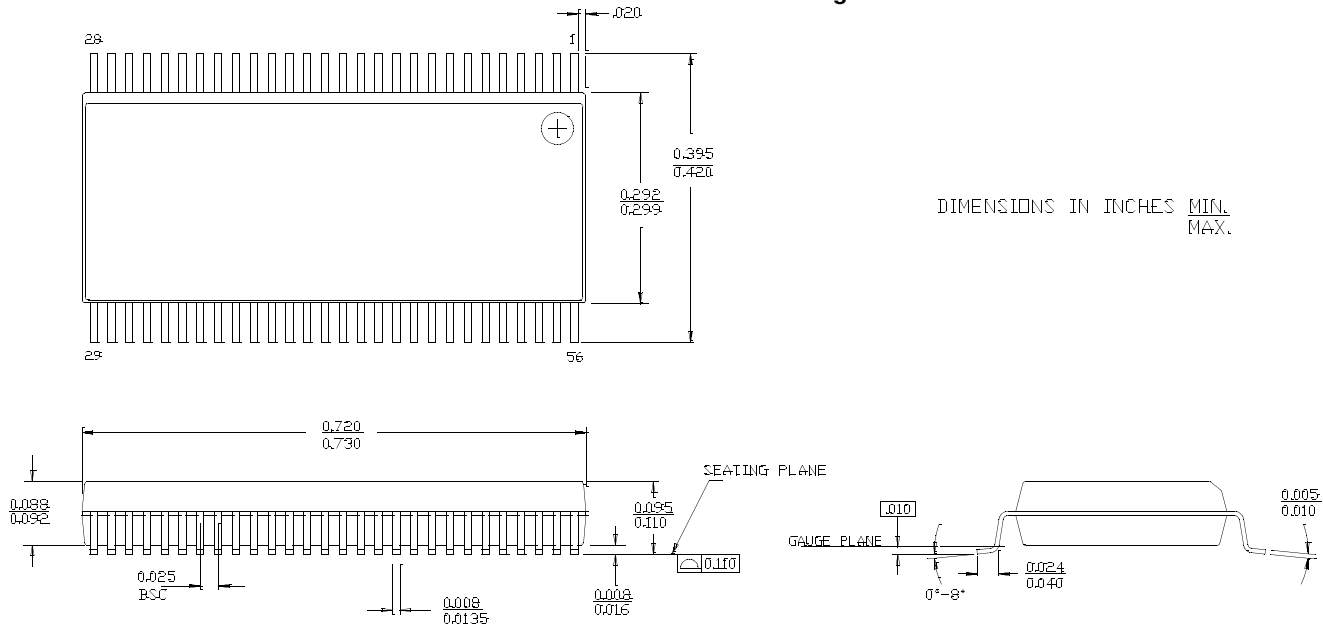

**56-Lead Thin Shrunk Small Outline Package, Type II (6 mm x 12 mm) Z56**

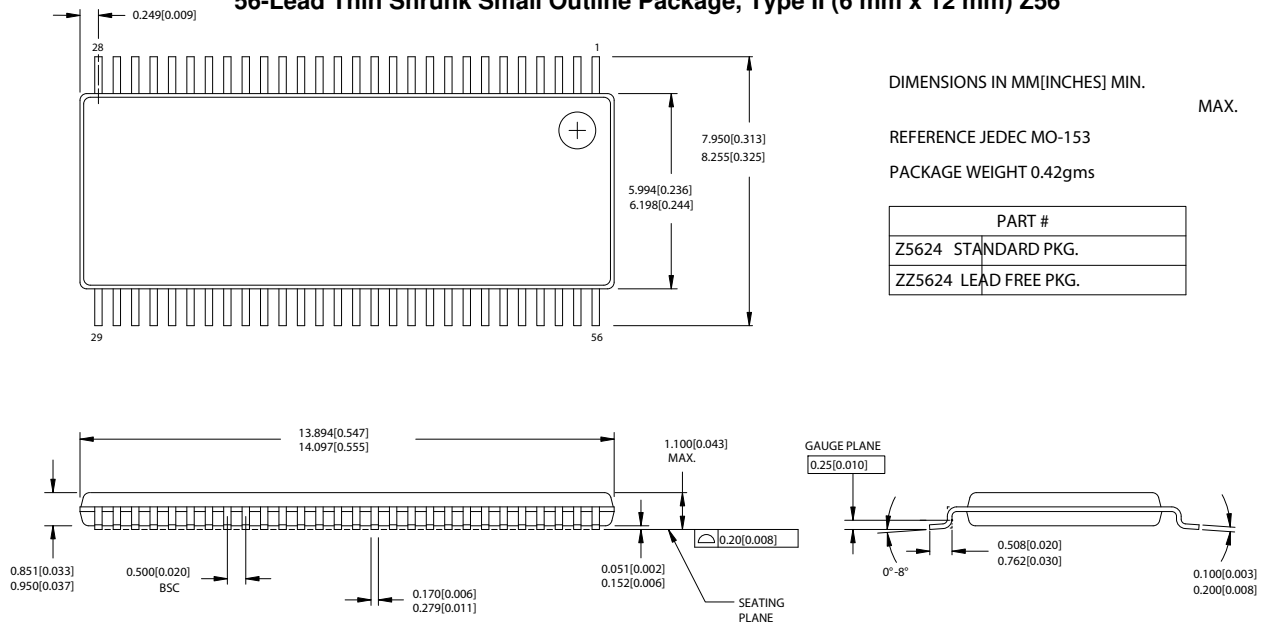

The information in this document is believed to be accurate in all respects at the time of publication but is subject to change without notice. Silicon Laboratories assumes no responsibility for errors and omissions, and disclaims responsibility for any consequences resulting from the use of information included herein. Additionally, Silicon Laboratories assumes no responsibility for the functioning of undescribed features or parameters. Silicon Laboratories reserves the right to make changes without further notice. Silicon Laboratories makes no warranty, representation or guarantee regarding the suitability of its products for any particular purpose, nor does Silicon Laboratories assume any liability arising out of the application or use of any product or circuit, and specifically disclaims any and all liability, including without limitation consequential or incidental damages. Silicon Laboratories products are not designed, intended, or authorized for use in applications intended to support or sustain life, or for any other application in which the failure of the Silicon Laboratories product could create a situation where personal injury or death may occur. Should Buyer purchase or use Silicon Laboratories products for any such unintended or unauthorized application, Buyer shall indemnify and hold Silicon Laboratories harmless against all claims and damages.