



Chipsmall Limited consists of a professional team with an average of over 10 year of expertise in the distribution of electronic components. Based in Hongkong, we have already established firm and mutual-benefit business relationships with customers from,Europe,America and south Asia,supplying obsolete and hard-to-find components to meet their specific needs.

With the principle of “Quality Parts,Customers Priority,Honest Operation,and Considerate Service”,our business mainly focus on the distribution of electronic components. Line cards we deal with include Microchip,ALPS,ROHM,Xilinx,Pulse,ON,Everlight and Freescale. Main products comprise IC,Modules,Potentiometer,IC Socket,Relay,Connector.Our parts cover such applications as commercial,industrial, and automotives areas.

We are looking forward to setting up business relationship with you and hope to provide you with the best service and solution. Let us make a better world for our industry!



Contact us

Tel: +86-755-8981 8866 Fax: +86-755-8427 6832

Email & Skype: info@chipsmall.com Web: www.chipsmall.com

Address: A1208, Overseas Decoration Building, #122 Zhenhua RD., Futian, Shenzhen, China





CY7C1263XV18

CY7C1265XV18

36-Mbit QDR[®] II+ Xtreme SRAM Four-Word Burst Architecture (2.5 Cycle Read Latency)

Features

- Separate Independent Read and Write Data Ports
 - Supports concurrent transactions
- 633 MHz Clock for High Bandwidth
- Four-word Burst for Reducing Address Bus Frequency
- Double Data Rate (DDR) Interfaces on both Read and Write Ports (data transferred at 1266 MHz) at 633 MHz
- Available in 2.5 Clock Cycle Latency
- Two Input Clocks (K and \bar{K}) for precise DDR Timing
 - SRAM uses rising edges only
- Echo Clocks (CQ and \bar{CQ}) simplify Data Capture in High Speed Systems
- Data Valid Pin (QVLD) to indicate Valid Data on the Output
- Single Multiplexed Address Input Bus latches Address Inputs for Read and Write Ports
- Separate Port selects for Depth Expansion
- Synchronous Internally Self-timed Writes
- QDR[®] II+ Xtreme operates with 2.5 cycle read latency when DOFF is asserted HIGH
- Operates similar to QDR I Device with one Cycle Read Latency when DOFF is asserted LOW
- Available in $\times 18$ and $\times 36$ Configurations
- Full Data Coherency, providing Most Current Data
- Core $V_{DD} = 1.8\text{ V} \pm 0.1\text{ V}$; I/O $V_{DDQ} = 1.4\text{ V}$ to 1.6 V
 - Supports 1.5 V I/O supply
- HSTL Inputs and Variable Drive HSTL Output Buffers
- Available in 165-ball FBGA Package ($13 \times 15 \times 1.4\text{ mm}$)
- Offered in Pb-free Packages
- JTAG 1149.1 compatible Test Access Port
- Phase-Locked Loop (PLL) for Accurate Data Placement

Configurations

With Read Cycle Latency of 2.5 cycles:

CY7C1263XV18 – $2\text{ M} \times 18$

CY7C1265XV18 – $1\text{ M} \times 36$

Functional Description

The CY7C1263XV18, and CY7C1265XV18 are 1.8 V Synchronous Pipelined SRAMs, equipped with QDR II+ architecture. Similar to QDR II architecture, QDR II+ architecture consists of two separate ports: the read port and the write port to access the memory array. The read port has dedicated data outputs to support read operations and the write port has dedicated data inputs to support write operations. QDR II+ architecture has separate data inputs and data outputs to completely eliminate the need to “turnaround” the data bus that exists with common I/O devices. Each port is accessed through a common address bus. Addresses for read and write addresses are latched on alternate rising edges of the input (K) clock. Accesses to the QDR II+ Xtreme read and write ports are completely independent of one another. To maximize data throughput, both read and write ports are equipped with DDR interfaces. Each address location is associated with four 18-bit words (CY7C1263XV18), or 36-bit words (CY7C1265XV18) that burst sequentially into or out of the device. Because data is transferred into and out of the device on every rising edge of both input clocks (K and \bar{K}), memory bandwidth is maximized while simplifying system design by eliminating bus “turnarounds”.

Depth expansion is accomplished with port selects, which enables each port to operate independently.

All synchronous inputs pass through input registers controlled by the K or \bar{K} input clocks. All data outputs pass through output registers controlled by the K or \bar{K} input clocks. Writes are conducted with on-chip synchronous self-timed write circuitry.

For a complete list of related documentation, click [here](#).

Selection Guide

Description		633 MHz	600 MHz	Unit
Maximum Operating Frequency		633	600	MHz
Maximum Operating Current	$\times 18$	1165	1100	mA
	$\times 36$	1660	1570	

Logic Block Diagram – CY7C1263XV18

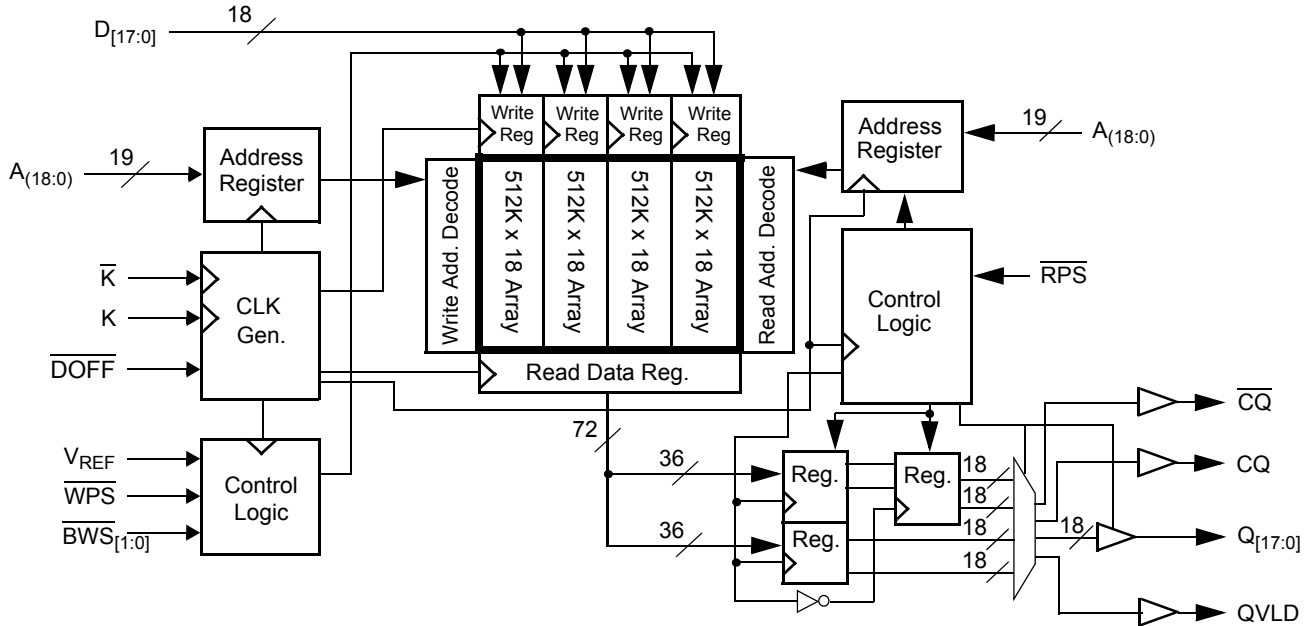

Logic Block Diagram – CY7C1265XV18

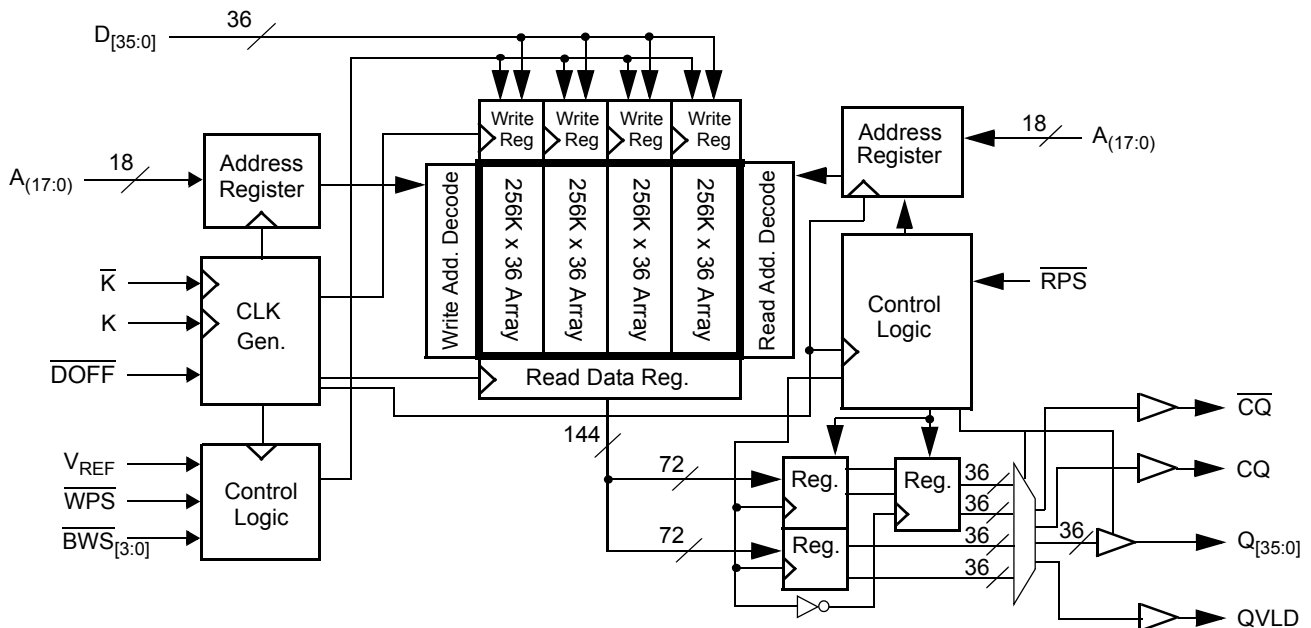

Contents

Pin Configurations	4	Boundary Scan Order	19
Pin Definitions	5	Power Up Sequence in QDR II+ Xtreme SRAM	20
Functional Overview	6	Power Up Sequence	20
Read Operations	6	PLL Constraints	20
Write Operations	6	Maximum Ratings	21
Byte Write Operations	7	Neutron Soft Error Immunity	21
Concurrent Transactions	7	Operating Range	21
Depth Expansion	7	Electrical Characteristics	21
Programmable Impedance	7	DC Electrical Characteristics	21
Echo Clocks	7	AC Electrical Characteristics	22
Valid Data Indicator (QVLD)	7	Capacitance	22
PLL	7	Thermal Resistance	22
Application Example	8	AC Test Loads and Waveforms	23
Truth Table	9	Switching Characteristics	24
Write Cycle Descriptions	10	Switching Waveforms	25
Write Cycle Descriptions	11	Read/Write/Deselect Sequence	25
IEEE 1149.1 Serial Boundary Scan (JTAG)	12	Ordering Information	26
Disabling the JTAG Feature	12	Ordering Code Definitions	26
Test Access Port	12	Package Diagram	27
Performing a TAP Reset	12	Acronyms	28
TAP Registers	12	Document Conventions	28
TAP Instruction Set	12	Units of Measures	28
TAP Controller State Diagram	14	Document History Page	29
TAP Controller Block Diagram	15	Sales, Solutions, and Legal Information	30
TAP Electrical Characteristics	15	Worldwide Sales and Design Support	30
TAP AC Switching Characteristics	16	Products	30
TAP Timing and Test Conditions	17	PSoC® Solutions	30
Identification Register Definitions	18	Cypress Developer Community	30
Scan Register Sizes	18	Technical Support	30
Instruction Codes	18		

Pin Configurations

The pin configurations for CY7C1263XV18, and CY7C1265XV18 follow. [1]

Figure 1. 165-ball FBGA (13 × 15 × 1.4 mm) pinout
CY7C1263XV18 (2 M × 18)

	1	2	3	4	5	6	7	8	9	10	11
A	CQ	NC/144M	A	WPS	BWS ₁	K	NC/288M	RPS	A	NC/72M	CQ
B	NC	Q9	D9	A	NC	K	BWS ₀	A	NC	NC	Q8
C	NC	NC	D10	V _{SS}	A	NC	A	V _{SS}	NC	Q7	D8
D	NC	D11	Q10	V _{SS}	V _{SS}	V _{SS}	V _{SS}	V _{SS}	NC	NC	D7
E	NC	NC	Q11	V _{DDQ}	V _{SS}	V _{SS}	V _{SS}	V _{DDQ}	NC	D6	Q6
F	NC	Q12	D12	V _{DDQ}	V _{DD}	V _{SS}	V _{DD}	V _{DDQ}	NC	NC	Q5
G	NC	D13	Q13	V _{DDQ}	V _{DD}	V _{SS}	V _{DD}	V _{DDQ}	NC	NC	D5
H	DOFF	V _{REF}	V _{DDQ}	V _{DDQ}	V _{DD}	V _{SS}	V _{DD}	V _{DDQ}	V _{DDQ}	V _{REF}	ZQ
J	NC	NC	D14	V _{DDQ}	V _{DD}	V _{SS}	V _{DD}	V _{DDQ}	NC	Q4	D4
K	NC	NC	Q14	V _{DDQ}	V _{DD}	V _{SS}	V _{DD}	V _{DDQ}	NC	D3	Q3
L	NC	Q15	D15	V _{DDQ}	V _{SS}	V _{SS}	V _{SS}	V _{DDQ}	NC	NC	Q2
M	NC	NC	D16	V _{SS}	V _{SS}	V _{SS}	V _{SS}	V _{SS}	NC	Q1	D2
N	NC	D17	Q16	V _{SS}	A	A	A	V _{SS}	NC	NC	D1
P	NC	NC	Q17	A	A	QVLD	A	A	NC	D0	Q0
R	TDO	TCK	A	A	A	NC	A	A	A	TMS	TDI

CY7C1265XV18 (1 M × 36)

	1	2	3	4	5	6	7	8	9	10	11
A	CQ	NC/288M	NC/72M	WPS	BWS ₂	K	BWS ₁	RPS	A	NC/144M	CQ
B	Q27	Q18	D18	A	BWS ₃	K	BWS ₀	A	D17	Q17	Q8
C	D27	Q28	D19	V _{SS}	A	NC	A	V _{SS}	D16	Q7	D8
D	D28	D20	Q19	V _{SS}	V _{SS}	V _{SS}	V _{SS}	V _{SS}	Q16	D15	D7
E	Q29	D29	Q20	V _{DDQ}	V _{SS}	V _{SS}	V _{SS}	V _{DDQ}	Q15	D6	Q6
F	Q30	Q21	D21	V _{DDQ}	V _{DD}	V _{SS}	V _{DD}	V _{DDQ}	D14	Q14	Q5
G	D30	D22	Q22	V _{DDQ}	V _{DD}	V _{SS}	V _{DD}	V _{DDQ}	Q13	D13	D5
H	DOFF	V _{REF}	V _{DDQ}	V _{DDQ}	V _{DD}	V _{SS}	V _{DD}	V _{DDQ}	V _{DDQ}	V _{REF}	ZQ
J	D31	Q31	D23	V _{DDQ}	V _{DD}	V _{SS}	V _{DD}	V _{DDQ}	D12	Q4	D4
K	Q32	D32	Q23	V _{DDQ}	V _{DD}	V _{SS}	V _{DD}	V _{DDQ}	Q12	D3	Q3
L	Q33	Q24	D24	V _{DDQ}	V _{SS}	V _{SS}	V _{SS}	V _{DDQ}	D11	Q11	Q2
M	D33	Q34	D25	V _{SS}	V _{SS}	V _{SS}	V _{SS}	V _{SS}	D10	Q1	D2
N	D34	D26	Q25	V _{SS}	A	A	A	V _{SS}	Q10	D9	D1
P	Q35	D35	Q26	A	A	QVLD	A	A	Q9	D0	Q0
R	TDO	TCK	A	A	A	NC	A	A	A	TMS	TDI

Note

1. NC/72M, NC/144M and NC/288M are not connected to the die and can be tied to any voltage level.

Pin Definitions

Pin Name	I/O	Pin Description
$D_{[x:0]}$	Input-Synchronous	Data Input Signals. Sampled on the rising edge of K and \bar{K} clocks when valid write operations are active. CY7C1263XV18 – $D_{[17:0]}$ CY7C1265XV18 – $D_{[35:0]}$
\overline{WPS}	Input-Synchronous	Write Port Select – Active LOW. Sampled on the rising edge of the K clock. When asserted active, a write operation is initiated. Deasserting deselects the write port. Deselecting the write port ignores $D_{[x:0]}$.
$\overline{BWS_0}$, $\overline{BWS_1}$, $\overline{BWS_2}$, $\overline{BWS_3}$	Input-Synchronous	Byte Write Select 0, 1, 2 and 3 – Active LOW. Sampled on the rising edge of the K and \bar{K} clocks when write operations are active. Used to select which byte is written into the device during the current portion of the write operations. Bytes not written remain unaltered. CY7C1263XV18 – $\overline{BWS_0}$ controls $D_{[8:0]}$ and $\overline{BWS_1}$ controls $D_{[17:9]}$. CY7C1265XV18 – $\overline{BWS_0}$ controls $D_{[8:0]}$, $\overline{BWS_1}$ controls $D_{[17:9]}$, $\overline{BWS_2}$ controls $D_{[26:18]}$ and $\overline{BWS_3}$ controls $D_{[35:27]}$. All the Byte Write Selects are sampled on the same edge as the data. Deselecting a Byte Write Select ignores the corresponding byte of data and it is not written into the device.
A	Input-Synchronous	Address Inputs. Sampled on the rising edge of the K clock during active read and write operations. These address inputs are multiplexed for both read and write operations. Internally, the device is organized as $2\text{ M} \times 18$ (4 arrays each of $512\text{ K} \times 18$) for CY7C1263XV18 and $1\text{ M} \times 36$ (4 arrays each of $256\text{ K} \times 36$) for CY7C1265XV18. Therefore, only 19 address inputs are needed to access the entire memory array for CY7C1263XV18 and 18 address inputs for CY7C1265XV18. These inputs are ignored when the appropriate port is deselected. The address pins (A) can be assigned any bit order.
$Q_{[x:0]}$	Outputs-Synchronous	Data Output Signals. These pins drive out the requested data when the read operation is active. Valid data is driven out on the rising edge of the K and \bar{K} clocks during read operations. On deselecting the read port, $Q_{[x:0]}$ are automatically tristated. CY7C1263XV18 – $Q_{[17:0]}$ CY7C1265XV18 – $Q_{[35:0]}$
\overline{RPS}	Input-Synchronous	Read Port Select – Active LOW. Sampled on the rising edge of positive input clock (K). When active, a read operation is initiated. Deasserting deselects the read port. When deselected, the pending access is allowed to complete and the output drivers are automatically tristated following the next rising edge of the \bar{K} clock. Each read access consists of a burst of four sequential transfers.
QVLD	Valid output indicator	Valid Output Indicator. The Q Valid indicates valid output data. QVLD is edge aligned with CQ and \bar{CQ} .
K	Input Clock	Positive Input Clock Input. The rising edge of K is used to capture synchronous inputs to the device and to drive out data through $Q_{[x:0]}$. All accesses are initiated on the rising edge of K.
\bar{K}	Input Clock	Negative Input Clock Input. \bar{K} is used to capture synchronous inputs being presented to the device and to drive out data through $Q_{[x:0]}$.
CQ	Echo Clock	Synchronous Echo Clock Outputs. This is a free running clock and is synchronized to the input clock (K) of the QDR II+ Xtreme. The timings for the echo clocks are shown in the Switching Characteristics on page 24 .
\bar{CQ}	Echo Clock	Synchronous Echo Clock Outputs. This is a free running clock and is synchronized to the input clock (K) of the QDR II+ Xtreme. The timings for the echo clocks are shown in the Switching Characteristics on page 24 .
ZQ	Input	Output Impedance Matching Input. This input is used to tune the device outputs to the system data bus impedance. CQ, \bar{CQ} , and $Q_{[x:0]}$ output impedance are set to $0.2 \times RQ$, where RQ is a resistor connected between ZQ and ground. Alternatively, this pin can be connected directly to V_{DDQ} , which enables the minimum impedance mode. This pin cannot be connected directly to GND or left unconnected.
\overline{DOFF}	Input	PLL Turn Off – Active LOW. Connecting this pin to ground turns off the PLL inside the device. The timings in the PLL turned off operation differs from those listed in this data sheet. For normal operation, this pin can be connected to a pull up through a $10\text{ K}\Omega$ or less pull up resistor. The device behaves in QDR I mode when the PLL is turned off. In this mode, the device can be operated at a frequency of up to 167 MHz with QDR I timing.

Pin Definitions (continued)

Pin Name	I/O	Pin Description
TDO	Output	TDO Pin for JTAG
TCK	Input	TCK Pin for JTAG
TDI	Input	TDI Pin for JTAG
TMS	Input	TMS Pin for JTAG
NC	N/A	Not Connected to the Die. Can be tied to any voltage level.
NC/72M	N/A	Not Connected to the Die. Can be tied to any voltage level.
NC/144M	N/A	Not Connected to the Die. Can be tied to any voltage level.
NC/288M	N/A	Not Connected to the Die. Can be tied to any voltage level.
V _{REF}	Input-Reference	Reference Voltage Input. Static input used to set the reference level for HSTL inputs, outputs, and AC measurement points.
V _{DD}	Power Supply	Power Supply Inputs to the Core of the Device
V _{SS}	Ground	Ground for the Device
V _{DDQ}	Power Supply	Power Supply Inputs for the Outputs of the Device

Functional Overview

The CY7C1263XV18 and CY7C1265XV18 are synchronous pipelined Burst SRAMs equipped with a read port and a write port. The read port is dedicated to read operations and the write port is dedicated to write operations. Data flows into the SRAM through the write port and flows out through the read port. These devices multiplex the address inputs to minimize the number of address pins required. By having separate read and write ports, the QDR II+ Xtreme completely eliminates the need to “turnaround” the data bus and avoids any possible data contention, thereby simplifying system design. Each access consists of four 18-bit data transfers in the case of CY7C1263XV18, and four 36-bit data transfers in the case of CY7C1265XV18, in two clock cycles.

These devices operate with a read latency of two and half cycles when $\overline{\text{DOFF}}$ pin is tied HIGH. When $\overline{\text{DOFF}}$ pin is set LOW or connected to V_{SS} then device behaves in QDR I mode with a read latency of one clock cycle.

Accesses for both ports are initiated on the positive input clock (K). All synchronous input and output timing are referenced from the rising edge of the input clocks (K and $\overline{\text{K}}$).

All synchronous data inputs (D_[x:0]) pass through input registers controlled by the input clocks (K and $\overline{\text{K}}$). All synchronous data outputs (Q_[x:0]) outputs pass through output registers controlled by the rising edge of the input clocks (K and $\overline{\text{K}}$) as well.

All synchronous control ($\overline{\text{RPS}}$, $\overline{\text{WPS}}$, $\overline{\text{BWS}}_{[x:0]}$) inputs pass through input registers controlled by the rising edge of the input clocks (K and $\overline{\text{K}}$).

CY7C1263XV18 is described in the following sections. The same basic descriptions apply to CY7C1265XV18.

Read Operations

The CY7C1263XV18 is organized internally as four arrays of 512 K × 18. Accesses are completed in a burst of four sequential 18-bit data words. Read operations are initiated by asserting

$\overline{\text{RPS}}$ active at the rising edge of the positive input clock (K). The address presented to the address inputs is stored in the read address register. Following the next two K clock rise, the corresponding lowest order 18-bit word of data is driven onto the Q_[17:0] using K as the output timing reference. On the subsequent rising edge of K, the next 18-bit data word is driven onto the Q_[17:0]. This process continues until all four 18-bit data words have been driven out onto Q_[17:0]. The requested data is valid 0.45 ns from the rising edge of the input clock (K or $\overline{\text{K}}$). To maintain the internal logic, each read access must be allowed to complete. Each read access consists of four 18-bit data words and takes two clock cycles to complete. Therefore, read accesses to the device can not be initiated on two consecutive K clock rises. The internal logic of the device ignores the second read request. Read accesses can be initiated on every other K clock rise. Doing so pipelines the data flow such that data is transferred out of the device on every rising edge of the input clocks (K and $\overline{\text{K}}$).

When the read port is deselected, the CY7C1263XV18 first completes the pending read transactions. Synchronous internal circuitry automatically tristates the outputs following the next rising edge of the negative input clock ($\overline{\text{K}}$). This enables for a seamless transition between devices without the insertion of wait states in a depth expanded memory.

Write Operations

Write operations are initiated by asserting $\overline{\text{WPS}}$ active at the rising edge of the positive input clock (K). On the following K clock rise the data presented to D_[17:0] is latched and stored into the lower 18-bit write data register, provided $\overline{\text{BWS}}_{[1:0]}$ are both asserted active. On the subsequent rising edge of the negative input clock ($\overline{\text{K}}$) the information presented to D_[17:0] is also stored into the write data register, provided $\overline{\text{BWS}}_{[1:0]}$ are both asserted active. This process continues for one more cycle until four 18-bit words (a total of 72 bits) of data are stored in the SRAM. The 72 bits of data are then written into the memory array at the specified location. Therefore, write accesses to the device can not be initiated on two consecutive K clock rises. The internal

logic of the device ignores the second write request. Write accesses can be initiated on every other rising edge of the positive input clock (K). Doing so pipelines the data flow such that 18 bits of data can be transferred into the device on every rising edge of the input clocks (K and \bar{K}).

When deselected, the write port ignores all inputs after the pending write operations have been completed.

Byte Write Operations

Byte write operations are supported by the CY7C1263XV18. A write operation is initiated as described in the [Write Operations on page 6](#). The bytes that are written are determined by BWS_0 and BWS_1 , which are sampled with each set of 18-bit data words. Asserting the appropriate Byte Write Select input during the data portion of a write latches the data being presented and writes it into the device. Deasserting the Byte Write Select input during the data portion of a write enables the data stored in the device for that byte to remain unaltered. This feature can be used to simplify read, modify, or write operations to a byte write operation.

Concurrent Transactions

The read and write ports on the CY7C1263XV18 operates completely independently of one another. As each port latches the address inputs on different clock edges, the user can read or write to any location, regardless of the transaction on the other port. If the ports access the same location when a read follows a write in successive clock cycles, the SRAM delivers the most recent information associated with the specified address location. This includes forwarding data from a write cycle that was initiated on the previous K clock rise.

Read access and write access must be scheduled such that one transaction is initiated on any clock cycle. If both ports are selected on the same K clock rise, the arbitration depends on the previous state of the SRAM. If both ports are deselected, the read port takes priority. If a read was initiated on the previous cycle, the write port takes priority (as read operations cannot be initiated on consecutive cycles). If a write was initiated on the previous cycle, the read port takes priority (as write operations can not be initiated on consecutive cycles). Therefore, asserting both port selects active from a deselected state results in alternating read or write operations being initiated, with the first access being a read.

Depth Expansion

The CY7C1263XV18 has a port select input for each port. This enables for easy depth expansion. Both port selects are sampled on the rising edge of the positive input clock only (K). Each port select input can deselect the specified port. Deselecting a port

does not affect the other port. All pending transactions (read and write) are completed before the device is deselected.

Programmable Impedance

An external resistor, RQ, must be connected between the ZQ pin on the SRAM and V_{SS} to allow the SRAM to adjust its output driver impedance. The value of RQ must be $5 \times$ the value of the intended line impedance driven by the SRAM, the allowable range of RQ to guarantee impedance matching with a tolerance of $\pm 15\%$ is between 175Ω and 350Ω , with $V_{DDQ} = 1.5 \text{ V}$. The output impedance is adjusted every 1024 cycles upon power up to account for drifts in supply voltage and temperature.

Echo Clocks

Echo clocks are provided on the QDR II+ Xtreme to simplify data capture on high-speed systems. Two echo clocks are generated by the QDR II+ Xtreme. CQ is referenced with respect to K and \bar{CQ} is referenced with respect to \bar{K} . These are free running clocks and are synchronized to the input clock of the QDR II+ Xtreme. The timing for the echo clocks is shown in the [Switching Characteristics on page 24](#).

Valid Data Indicator (QVLD)

QVLD is provided on the QDR II+ Xtreme to simplify data capture on high speed systems. The QVLD is generated by the QDR II+ Xtreme device along with data output. This signal is also edge-aligned with the echo clock and follows the timing of any data pin. This signal is asserted half a cycle before valid data arrives.

PLL

These chips use a PLL that is designed to function between 120 MHz and the specified maximum clock frequency. During power up, when the $\overline{\text{DOFF}}$ is tied HIGH, the PLL is locked after $100 \mu\text{s}$ of stable clock. The PLL can also be reset by slowing or stopping the input clocks K and \bar{K} for a minimum of 30 ns. However, it is not necessary to reset the PLL to lock to the desired frequency. The PLL automatically locks $100 \mu\text{s}$ after a stable clock is presented. The PLL may be disabled by applying ground to the $\overline{\text{DOFF}}$ pin. When the PLL is turned off, the device behaves in QDR I mode (with one cycle latency and a longer access time). For information, refer to the application note, *PLL Considerations in QDRII/DDRII/QDRII+/DDRII+*.

Application Example

Figure 2 shows two QDR II+ Xtreme used in an application.

Figure 2. Application Example (Width Expansion)

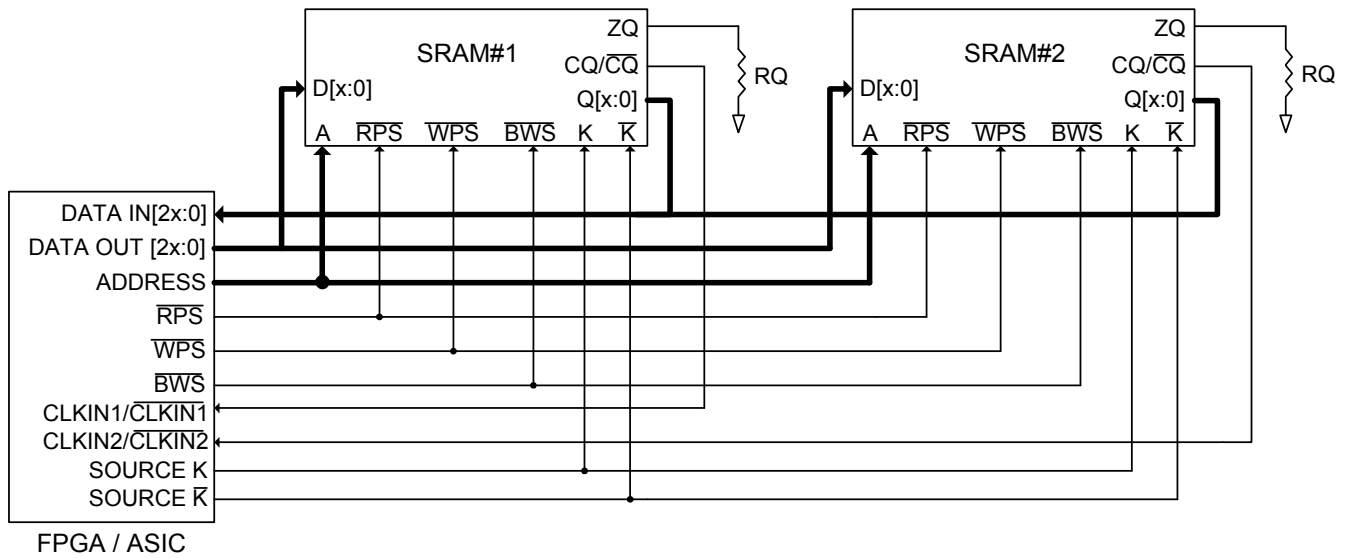

Truth Table

The truth table for CY7C1263XV18, and CY7C1265XV18 follows. [2, 3, 4, 5, 6, 7]

Operation	K	\overline{RPS}	\overline{WPS}	DQ	DQ	DQ	DQ
Write Cycle: Load address on the rising edge of K; input write data on two consecutive K and \overline{K} rising edges.	L–H	H ^[8]	L ^[9]	D(A) at K(t + 1)↑	D(A + 1) at $\overline{K}(t + 1)$ ↑	D(A + 2) at K(t + 2)↑	D(A + 3) at $\overline{K}(t + 2)$ ↑
Read Cycle: (2.5 cycle Latency) Load address on the rising edge of K; wait two and half cycles; read_data on two consecutive K and \overline{K} rising edges.	L–H	L ^[9]	X	Q(A) at $\overline{K}(t + 2)$ ↑	Q(A + 1) at K(t + 3)↑	Q(A + 2) at $\overline{K}(t + 3)$ ↑	Q(A + 3) at K(t + 4)↑
NOP: No Operation	L–H	H	H	D = X Q = High Z	D = X Q = High Z	D = X Q = High Z	D = X Q = High Z
Standby: Clock Stopped	Stopped	X	X	Previous State	Previous State	Previous State	Previous State

Notes

2. X = "Don't Care," H = Logic HIGH, L = Logic LOW, ↑ represents rising edge.
3. Device powers up deselected with the outputs in a tristate condition.
4. "A" represents address location latched by the devices when transaction was initiated. A + 1, A + 2, and A + 3 represents the address sequence in the burst.
5. "t" represents the cycle at which a read/write operation is started. t + 1, t + 2, and t + 3 are the first, second and third clock cycles respectively succeeding the "t" clock cycle.
6. Data inputs are registered at K and \overline{K} rising edges. Data outputs are delivered on K and \overline{K} rising edges as well.
7. It is recommended that K = \overline{K} = HIGH when clock is stopped. This is not essential, but permits most rapid restart by overcoming transmission line charging symmetrically.
8. If this signal was LOW to initiate the previous cycle, this signal becomes a "Don't Care" for this operation.
9. This signal was HIGH on previous K clock rise. Initiating consecutive read or write operations on consecutive K clock rises is not permitted. The device ignores the second read or write request.

Write Cycle Descriptions

The write cycle description table for CY7C1263XV18 follows. [10, 11]

$\overline{\text{BWS}}_0$	$\overline{\text{BWS}}_1$	K	$\overline{\text{K}}$	Comments
L	L	L-H	-	During the data portion of a write sequence: CY7C1263XV18 – both bytes ($D_{[17:0]}$) are written into the device.
L	L	-	L-H	During the data portion of a write sequence: CY7C1263XV18 – both bytes ($D_{[17:0]}$) are written into the device.
L	H	L-H	-	During the data portion of a write sequence: CY7C1263XV18 – only the lower byte ($D_{[8:0]}$) is written into the device, $D_{[17:9]}$ remains unaltered.
L	H	-	L-H	During the data portion of a write sequence: CY7C1263XV18 – only the lower byte ($D_{[8:0]}$) is written into the device, $D_{[17:9]}$ remains unaltered.
H	L	L-H	-	During the data portion of a write sequence: CY7C1263XV18 – only the upper byte ($D_{[17:9]}$) is written into the device, $D_{[8:0]}$ remains unaltered.
H	L	-	L-H	During the data portion of a write sequence: CY7C1263XV18 – only the upper byte ($D_{[17:9]}$) is written into the device, $D_{[8:0]}$ remains unaltered.
H	H	L-H	-	No data is written into the devices during this portion of a write operation.
H	H	-	L-H	No data is written into the devices during this portion of a write operation.

Notes

10. X = "Don't Care," H = Logic HIGH, L = Logic LOW, \uparrow represents rising edge.

11. Is based on a write cycle that was initiated in accordance with above Truth Table on page 9. $\overline{\text{BWS}}_0$, $\overline{\text{BWS}}_1$, $\overline{\text{BWS}}_2$, $\overline{\text{BWS}}_3$ can be altered on different portions of a write cycle, as long as the setup and hold requirements are achieved.

Write Cycle Descriptions

The write cycle description table for CY7C1265XV18 follows. [12, 13]

$\overline{\text{BWS}}_0$	$\overline{\text{BWS}}_1$	$\overline{\text{BWS}}_2$	$\overline{\text{BWS}}_3$	K	$\overline{\text{K}}$	Comments
L	L	L	L	L-H	-	During the data portion of a write sequence, all four bytes ($D_{[35:0]}$) are written into the device.
L	L	L	L	-	L-H	During the data portion of a write sequence, all four bytes ($D_{[35:0]}$) are written into the device.
L	H	H	H	L-H	-	During the data portion of a write sequence, only the lower byte ($D_{[8:0]}$) is written into the device. $D_{[35:9]}$ remains unaltered.
L	H	H	H	-	L-H	During the data portion of a write sequence, only the lower byte ($D_{[8:0]}$) is written into the device. $D_{[35:9]}$ remains unaltered.
H	L	H	H	L-H	-	During the data portion of a write sequence, only the byte ($D_{[17:9]}$) is written into the device. $D_{[8:0]}$ and $D_{[35:18]}$ remains unaltered.
H	L	H	H	-	L-H	During the data portion of a write sequence, only the byte ($D_{[17:9]}$) is written into the device. $D_{[8:0]}$ and $D_{[35:18]}$ remains unaltered.
H	H	L	H	L-H	-	During the data portion of a write sequence, only the byte ($D_{[26:18]}$) is written into the device. $D_{[17:0]}$ and $D_{[35:27]}$ remains unaltered.
H	H	L	H	-	L-H	During the data portion of a write sequence, only the byte ($D_{[26:18]}$) is written into the device. $D_{[17:0]}$ and $D_{[35:27]}$ remains unaltered.
H	H	H	L	L-H	-	During the data portion of a write sequence, only the byte ($D_{[35:27]}$) is written into the device. $D_{[26:0]}$ remains unaltered.
H	H	H	L	-	L-H	During the data portion of a write sequence, only the byte ($D_{[35:27]}$) is written into the device. $D_{[26:0]}$ remains unaltered.
H	H	H	H	L-H	-	No data is written into the device during this portion of a write operation.
H	H	H	H	-	L-H	No data is written into the device during this portion of a write operation.

Notes

12. X = "Don't Care," H = Logic HIGH, L = Logic LOW, \uparrow represents rising edge.

13. Is based on a write cycle that was initiated in accordance with above Truth Table on page 9. $\overline{\text{BWS}}_0$, $\overline{\text{BWS}}_1$, $\overline{\text{BWS}}_2$, $\overline{\text{BWS}}_3$ can be altered on different portions of a write cycle, as long as the setup and hold requirements are achieved.

IEEE 1149.1 Serial Boundary Scan (JTAG)

These SRAMs incorporate a serial boundary scan Test Access Port (TAP) in the FBGA package. This part is fully compliant with IEEE Standard #1149.1-2001. The TAP operates using JEDEC standard 1.8 V I/O logic levels.

Disabling the JTAG Feature

It is possible to operate the SRAM without using the JTAG feature. To disable the TAP controller, TCK must be tied LOW (V_{SS}) to prevent clocking of the device. TDI and TMS are internally pulled up and may be unconnected. They may alternatively be connected to V_{DD} through a pull up resistor. TDO must be left unconnected. Upon power up, the device comes up in a reset state, which does not interfere with the operation of the device.

Test Access Port

Test Clock

The test clock is used only with the TAP controller. All inputs are captured on the rising edge of TCK. All outputs are driven from the falling edge of TCK.

Test Mode Select (TMS)

The TMS input is used to give commands to the TAP controller and is sampled on the rising edge of TCK. This pin may be left unconnected if the TAP is not used. The pin is pulled up internally, resulting in a logic HIGH level.

Test Data-In (TDI)

The TDI pin is used to serially input information into the registers and can be connected to the input of any of the registers. The register between TDI and TDO is chosen by the instruction that is loaded into the TAP instruction register. For information on loading the instruction register, see [TAP Controller State Diagram on page 14](#). TDI is internally pulled up and can be unconnected if the TAP is unused in an application. TDI is connected to the most significant bit (MSB) on any register.

Test Data-Out (TDO)

The TDO output pin is used to serially clock data out from the registers. The output is active, depending upon the current state of the TAP state machine (see [Instruction Codes on page 18](#)). The output changes on the falling edge of TCK. TDO is connected to the least significant bit (LSB) of any register.

Performing a TAP Reset

A Reset is performed by forcing TMS HIGH (V_{DD}) for five rising edges of TCK. This Reset does not affect the operation of the SRAM and can be performed while the SRAM is operating. At power up, the TAP is reset internally to ensure that TDO comes up in a High Z state.

TAP Registers

Registers are connected between the TDI and TDO pins to scan the data in and out of the SRAM test circuitry. Only one register can be selected at a time through the instruction registers. Data is serially loaded into the TDI pin on the rising edge of TCK. Data is output on the TDO pin on the falling edge of TCK.

Instruction Register

Three-bit instructions can be serially loaded into the instruction register. This register is loaded when it is placed between the TDI and TDO pins, as shown in [TAP Controller Block Diagram on page 15](#). Upon power up, the instruction register is loaded with the IDCODE instruction. It is also loaded with the IDCODE instruction if the controller is placed in a reset state, as described in the previous section.

When the TAP controller is in the Capture-IR state, the two least significant bits are loaded with a binary "01" pattern to allow for fault isolation of the board level serial test path.

Bypass Register

To save time when serially shifting data through registers, it is sometimes advantageous to skip certain chips. The bypass register is a single-bit register that can be placed between TDI and TDO pins. This enables shifting of data through the SRAM with minimal delay. The bypass register is set LOW (V_{SS}) when the BYPASS instruction is executed.

Boundary Scan Register

The boundary scan register is connected to all of the input and output pins on the SRAM. Several No Connect (NC) pins are also included in the scan register to reserve pins for higher density devices.

The boundary scan register is loaded with the contents of the RAM input and output ring when the TAP controller is in the Capture-DR state and is then placed between the TDI and TDO pins when the controller is moved to the Shift-DR state. The EXTEST, SAMPLE/PRELOAD, and SAMPLE Z instructions can be used to capture the contents of the input and output ring.

The section [Boundary Scan Order on page 19](#) shows the order in which the bits are connected. Each bit corresponds to one of the bumps on the SRAM package. The MSB of the register is connected to TDI, and the LSB is connected to TDO.

Identification (ID) Register

The ID register is loaded with a vendor-specific, 32-bit code during the Capture-DR state when the IDCODE command is loaded in the instruction register. The IDCODE is hardwired into the SRAM and can be shifted out when the TAP controller is in the Shift-DR state. The ID register has a vendor code and other information described in [Identification Register Definitions on page 18](#).

TAP Instruction Set

Eight different instructions are possible with the three-bit instruction register. All combinations are listed in [Instruction Codes on page 18](#). Three of these instructions are listed as RESERVED and must not be used. The other five instructions are described in this section in detail.

Instructions are loaded into the TAP controller during the Shift-IR state when the instruction register is placed between TDI and TDO. During this state, instructions are shifted through the instruction register through the TDI and TDO pins. To execute the instruction after it is shifted in, the TAP controller must be moved into the Update-IR state.

IDCODE

The IDCODE instruction loads a vendor-specific, 32-bit code into the instruction register. It also places the instruction register between the TDI and TDO pins and shifts the IDCODE out of the device when the TAP controller enters the Shift-DR state. The IDCODE instruction is loaded into the instruction register at power up or whenever the TAP controller is supplied a Test-Logic-Reset state.

SAMPLE Z

The SAMPLE Z instruction connects the boundary scan register between the TDI and TDO pins when the TAP controller is in a Shift-DR state. The SAMPLE Z command puts the output bus into a High Z state until the next command is supplied during the Update IR state.

SAMPLE/PRELOAD

SAMPLE/PRELOAD is a 1149.1 mandatory instruction. When the SAMPLE/PRELOAD instructions are loaded into the instruction register and the TAP controller is in the Capture-DR state, a snapshot of data on the input and output pins is captured in the boundary scan register.

The TAP controller clock can only operate at a frequency up to 20 MHz, while the SRAM clock operates more than an order of magnitude faster. Because there is a large difference in the clock frequencies, it is possible that during the Capture-DR state, an input or output undergoes a transition. The TAP may then try to capture a signal while in transition (metastable state). This does not harm the device, but there is no guarantee as to the value that is captured. Repeatable results may not be possible.

To guarantee that the boundary scan register captures the correct value of a signal, the SRAM signal must be stabilized long enough to meet the TAP controller's capture setup plus hold times (t_{CS} and t_{CH}). The SRAM clock input might not be captured correctly if there is no way in a design to stop (or slow) the clock during a SAMPLE/PRELOAD instruction. If this is an issue, it is still possible to capture all other signals and simply ignore the value of the CK and CK captured in the boundary scan register.

After the data is captured, it is possible to shift out the data by putting the TAP into the Shift-DR state. This places the boundary scan register between the TDI and TDO pins.

PRELOAD places an initial data pattern at the latched parallel outputs of the boundary scan register cells before the selection of another boundary scan test operation.

The shifting of data for the SAMPLE and PRELOAD phases can occur concurrently when required, that is, while the data captured is shifted out, the preloaded data can be shifted in.

BYPASS

When the BYPASS instruction is loaded in the instruction register and the TAP is placed in a Shift-DR state, the bypass register is placed between the TDI and TDO pins. The advantage of the BYPASS instruction is that it shortens the boundary scan path when multiple devices are connected together on a board.

EXTEST

The EXTEST instruction drives the preloaded data out through the system output pins. This instruction also connects the boundary scan register for serial access between the TDI and TDO in the Shift-DR controller state.

EXTEST OUTPUT BUS TRISTATE

IEEE Standard 1149.1 mandates that the TAP controller be able to put the output bus into a tristate mode.

The boundary scan register has a special bit located at bit #108. When this scan cell, called the "extest output bus tristate," is latched into the preload register during the Update-DR state in the TAP controller, it directly controls the state of the output (Q-bus) pins, when the EXTEST is entered as the current instruction. When HIGH, it enables the output buffers to drive the output bus. When LOW, this bit places the output bus into a High Z condition.

This bit can be set by entering the SAMPLE/PRELOAD or EXTEST command, and then shifting the desired bit into that cell, during the Shift-DR state. During Update-DR, the value loaded into that shift-register cell latches into the preload register. When the EXTEST instruction is entered, this bit directly controls the output Q-bus pins. Note that this bit is preset HIGH to enable the output when the device is powered up, and also when the TAP controller is in the Test-Logic-Reset state.

Reserved

These instructions are not implemented but are reserved for future use. Do not use these instructions.

TAP Controller State Diagram

The state diagram for the TAP controller follows. ^[14]

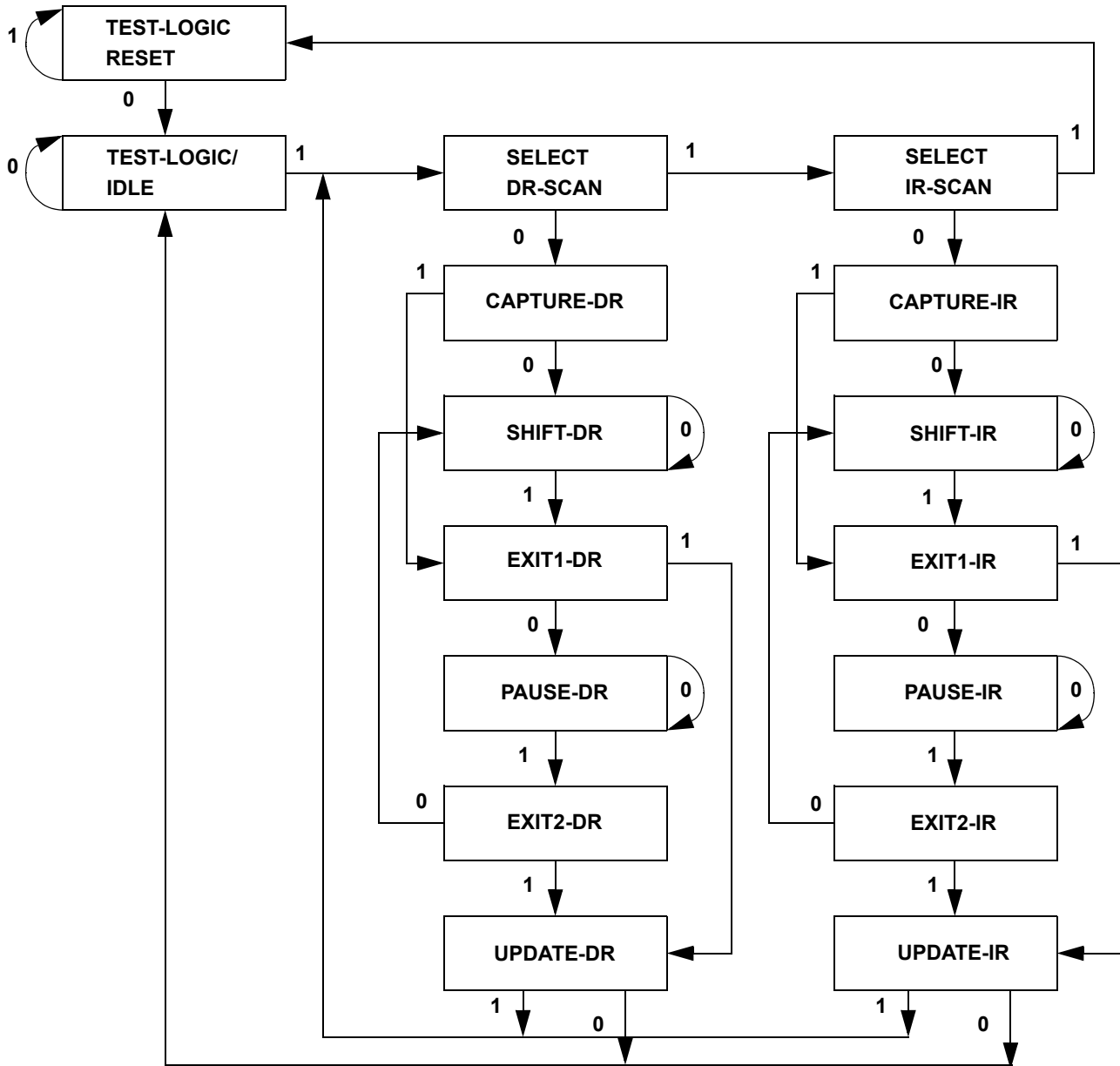

Note
14. The 0/1 next to each state represents the value at TMS at the rising edge of TCK.

TAP Controller Block Diagram

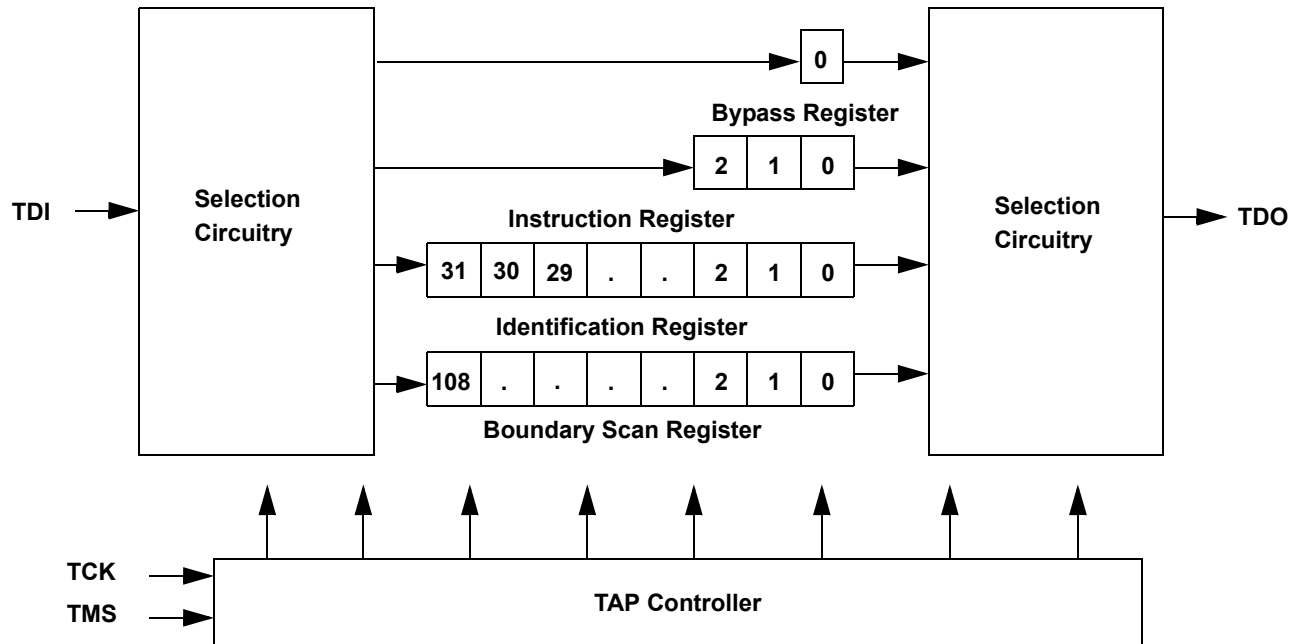

TAP Electrical Characteristics

Over the Operating Range

Parameter ^[15, 16, 17]	Description	Test Conditions	Min	Max	Unit
V _{OH1}	Output HIGH Voltage	I _{OH} = -2.0 mA	1.4	-	V
V _{OH2}	Output HIGH Voltage	I _{OH} = -100 μA	1.6	-	V
V _{OL1}	Output LOW Voltage	I _{OL} = 2.0 mA	-	0.4	V
V _{OL2}	Output LOW Voltage	I _{OL} = 100 μA	-	0.2	V
V _{IH}	Input HIGH Voltage		0.65 × V _{DD}	V _{DD} + 0.3	V
V _{IL}	Input LOW Voltage		-0.3	0.35 × V _{DD}	V
I _X	Input and Output Load Current	GND ≤ V _I ≤ V _{DD}	-5	5	μA

Notes

15. These characteristics pertain to the TAP inputs (TMS, TCK, TDI and TDO). Parallel load levels are specified in the [Electrical Characteristics on page 21](#).
16. Overshoot: V_{IH(AC)} ≤ V_{DD} + 0.35 V (Pulse width less than t_{TCYC/2}). Undershoot: V_{IL(AC)} ≥ -0.3 V (Pulse width less than t_{TCYC/2}).
17. All Voltage referenced to Ground.

TAP AC Switching Characteristics

Over the Operating Range

Parameter ^[18, 19]	Description	Min	Max	Unit
t_{TCYC}	TCK Clock Cycle Time	50	–	ns
t_{TF}	TCK Clock Frequency	–	20	MHz
t_{TH}	TCK Clock HIGH	20	–	ns
t_{TL}	TCK Clock LOW	20	–	ns
Setup Times				
t_{TMSS}	TMS Setup to TCK Clock Rise	5	–	ns
t_{TDIS}	TDI Setup to TCK Clock Rise	5	–	ns
t_{CS}	Capture Setup to TCK Rise	5	–	ns
Hold Times				
t_{TMSH}	TMS Hold after TCK Clock Rise	5	–	ns
t_{TDIH}	TDI Hold after Clock Rise	5	–	ns
t_{CH}	Capture Hold after Clock Rise	5	–	ns
Output Times				
t_{TDOV}	TCK Clock LOW to TDO Valid	–	10	ns
t_{TDOX}	TCK Clock LOW to TDO Invalid	0	–	ns

Notes

18. t_{CS} and t_{CH} refer to the setup and hold time requirements of latching data from the boundary scan register.
 19. Test conditions are specified using the load in TAP AC Test Conditions. $t_R/t_F = 1$ V/ns.

TAP Timing and Test Conditions

Figure 3 shows the TAP timing and test conditions. [20]

Figure 3. TAP Timing and Test Conditions

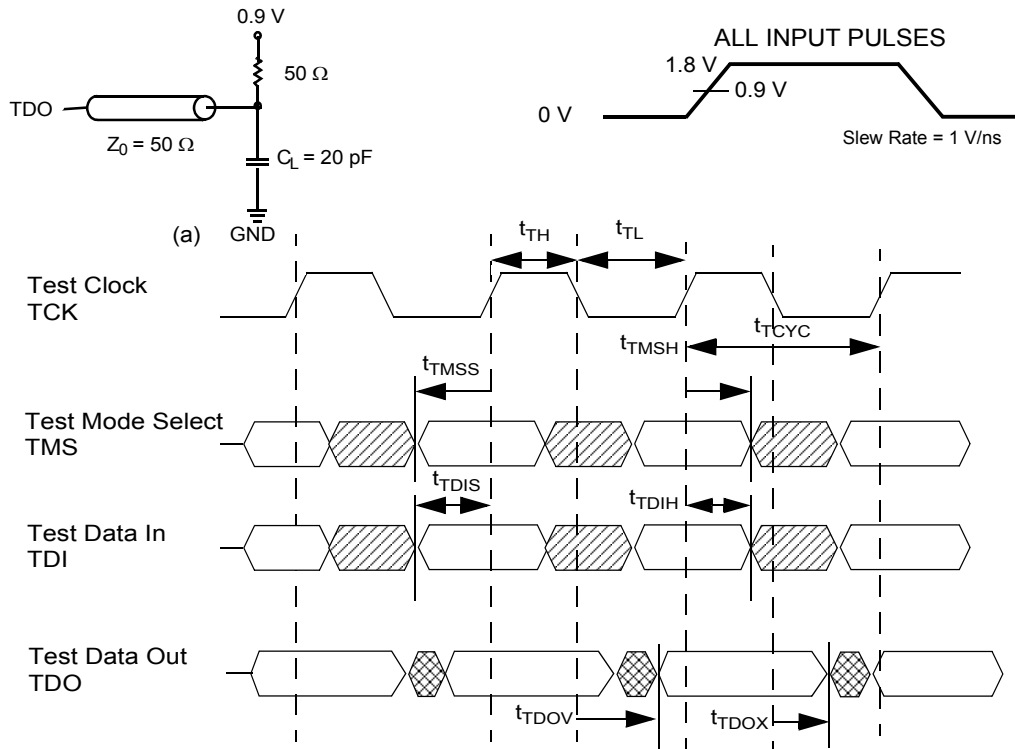

Note

20. Test conditions are specified using the load in TAP AC Test Conditions. $t_R/t_F = 1 \text{ V/ns}$.

Identification Register Definitions

Instruction Field	Value		Description
	CY7C1263XV18	CY7C1265XV18	
Revision Number (31:29)	000	000	Version number.
Cypress Device ID (28:12)	11010010001010100	11010010001100100	Defines the type of SRAM.
Cypress JEDEC ID (11:1)	00000110100	00000110100	Allows unique identification of SRAM vendor.
ID Register Presence (0)	1	1	Indicates the presence of an ID register.

Scan Register Sizes

Register Name	Bit Size
Instruction	3
Bypass	1
ID	32
Boundary Scan	109

Instruction Codes

Instruction	Code	Description
EXTEST	000	Captures the input and output ring contents.
IDCODE	001	Loads the ID register with the vendor ID code and places the register between TDI and TDO. This operation does not affect SRAM operation.
SAMPLE Z	010	Captures the input and output contents. Places the boundary scan register between TDI and TDO. Forces all SRAM output drivers to a High Z state.
RESERVED	011	Do Not Use: This instruction is reserved for future use.
SAMPLE/PRELOAD	100	Captures the input and output ring contents. Places the boundary scan register between TDI and TDO. Does not affect the SRAM operation.
RESERVED	101	Do Not Use: This instruction is reserved for future use.
RESERVED	110	Do Not Use: This instruction is reserved for future use.
BYPASS	111	Places the bypass register between TDI and TDO. This operation does not affect SRAM operation.

Boundary Scan Order

Bit #	Bump ID
0	6R
1	6P
2	6N
3	7P
4	7N
5	7R
6	8R
7	8P
8	9R
9	11P
10	10P
11	10N
12	9P
13	10M
14	11N
15	9M
16	9N
17	11L
18	11M
19	9L
20	10L
21	11K
22	10K
23	9J
24	9K
25	10J
26	11J
27	11H

Bit #	Bump ID
28	10G
29	9G
30	11F
31	11G
32	9F
33	10F
34	11E
35	10E
36	10D
37	9E
38	10C
39	11D
40	9C
41	9D
42	11B
43	11C
44	9B
45	10B
46	11A
47	10A
48	9A
49	8B
50	7C
51	6C
52	8A
53	7A
54	7B
55	6B

Bit #	Bump ID
56	6A
57	5B
58	5A
59	4A
60	5C
61	4B
62	3A
63	2A
64	1A
65	2B
66	3B
67	1C
68	1B
69	3D
70	3C
71	1D
72	2C
73	3E
74	2D
75	2E
76	1E
77	2F
78	3F
79	1G
80	1F
81	3G
82	2G
83	1H

Bit #	Bump ID
84	1J
85	2J
86	3K
87	3J
88	2K
89	1K
90	2L
91	3L
92	1M
93	1L
94	3N
95	3M
96	1N
97	2M
98	3P
99	2N
100	2P
101	1P
102	3R
103	4R
104	4P
105	5P
106	5N
107	5R
108	Internal

Power Up Sequence in QDR II+ Xtreme SRAM

QDR II+ Xtreme SRAMs must be powered up and initialized in a predefined manner to prevent undefined operations.

Power Up Sequence

- Apply power and drive $\overline{\text{DOFF}}$ either HIGH or LOW (All other inputs can be HIGH or LOW).
 - Apply V_{DD} before V_{DDQ} .
 - Apply V_{DDQ} before V_{REF} or at the same time as V_{REF} .
 - Drive $\overline{\text{DOFF}}$ HIGH.
- Provide stable $\overline{\text{DOFF}}$ (HIGH), power and clock (K, $\overline{\text{K}}$) for 100 μs to lock the PLL.

PLL Constraints

- PLL uses K clock as its synchronizing input. The input must have low phase jitter, which is specified as $t_{\text{KC Var}}$.
- The PLL functions at frequencies down to 120 MHz.
- If the input clock is unstable and the PLL is enabled, then the PLL may lock onto an incorrect frequency, causing unstable SRAM behavior. To avoid this, provide 100 μs of stable clock to relock to the desired clock frequency.

Figure 4. Power Up Waveforms

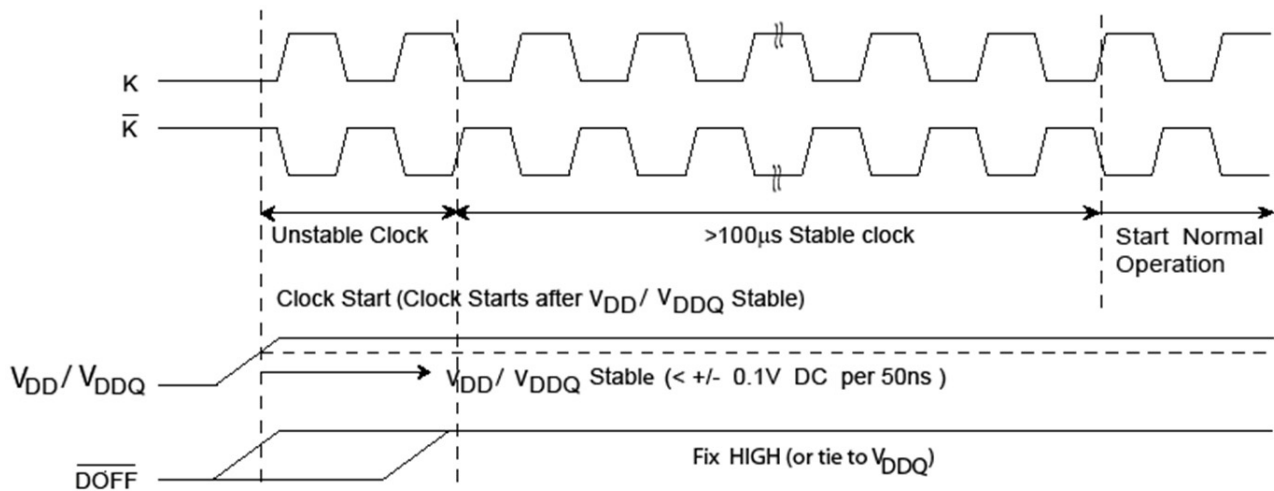

Maximum Ratings

Exceeding maximum ratings may impair the useful life of the device. These user guidelines are not tested.

Storage Temperature	-65 °C to +150 °C
Supply Voltage on V _{DD} Relative to GND	-0.5 V to +2.9 V
Supply Voltage on V _{DDQ} Relative to GND	-0.5 V to +V _{DD}
DC Applied to Outputs in High Z	-0.5 V to V _{DDQ} + 0.3 V
DC Input Voltage ^[21]	-0.5 V to V _{DD} + 0.3 V
Current into Outputs (LOW)	20 mA
Static Discharge Voltage (MIL-STD-883, M. 3015)	> 2,001V
Latch up Current	> 200 mA
Maximum Junction Temperature.....	125 °C

Neutron Soft Error Immunity

Parameter	Description	Test Conditions	Typ	Max*	Unit
LSBU	Logical Single-Bit Upsets	25 °C	260	271	FIT/Mb
LMBU	Logical Multi-Bit Upsets	25 °C	0	0.01	FIT/Mb
SEL	Single Event Latchup	85 °C	0	0.1	FIT/D ev

* No LMBU or SEL events occurred during testing; this column represents a statistical χ^2 , 95% confidence limit calculation. For more details refer to Application Note AN54908 "Accelerated Neutron SER Testing and Calculation of Terrestrial Failure Rates"

Operating Range

Range	Ambient Temperature (T _A)	V _{DD} ^[22]	V _{DDQ} ^[22]
Commercial	0 °C to +70 °C	1.8 ± 0.1 V	1.4 V to 1.6 V

Electrical Characteristics

Over the Operating Range

DC Electrical Characteristics

Over the Operating Range

Parameter ^[23]	Description	Test Conditions	Min	Typ	Max	Unit		
V _{DD}	Power Supply Voltage		1.7	1.8	1.9	V		
V _{DDQ}	I/O Supply Voltage		1.4	1.5	1.6	V		
V _{OH}	Output HIGH Voltage	Note 24	V _{DDQ} /2 - 0.12	-	V _{DDQ} /2 + 0.12	V		
V _{OL}	Output LOW Voltage	Note 25	V _{DDQ} /2 - 0.12	-	V _{DDQ} /2 + 0.12	V		
V _{OH(LOW)}	Output HIGH Voltage	I _{OH} = -0.1 mA, Nominal Impedance	V _{DDQ} - 0.2	-	V _{DDQ}	V		
V _{OL(LOW)}	Output LOW Voltage	I _{OL} = 0.1 mA, Nominal Impedance	V _{SS}	-	0.2	V		
V _{IH}	Input HIGH Voltage		V _{REF} + 0.1	-	V _{DDQ} + 0.15	V		
V _{IL}	Input LOW Voltage		-0.15	-	V _{REF} - 0.1	V		
I _X	Input Leakage Current	GND ≤ V _I ≤ V _{DDQ}	-2	-	2	μA		
I _{OZ}	Output Leakage Current	GND ≤ V _I ≤ V _{DDQ} , Output Disabled	-2	-	2	μA		
V _{REF}	Input Reference Voltage	Typical Value = 0.75 V	0.68	0.75	0.86	V		
I _{DD} ^[26]	V _{DD} Operating Supply	V _{DD} = Max, I _{OUT} = 0 mA, f = f _{MAX} = 1/t _{CYC}	633 MHz	(× 18)	-	-	1165	mA
				(× 36)	-	-	1660	
		600 MHz	(× 18)	-	-	1100	mA	
			(× 36)	-	-	1570		

Notes

21. Overshoot: V_{IH(AC)} ≤ V_{DDQ} + 0.35 V (Pulse width less than t_{CYC}/2), Undershoot: V_{IL(AC)} ≥ -0.3 V (Pulse width less than t_{CYC}/2).

22. Power up: Assumes a linear ramp from 0V to V_{DD(min)} within 200 ms. During this time V_{IH} < V_{DD} and V_{DDQ} ≤ V_{DD}.

23. All Voltage referenced to Ground.

24. Outputs are impedance controlled. I_{OH} = -(V_{DDQ}/2)/(RQ/5) for values of 175 ohms ≤ RQ ≤ 350 ohms.

25. Outputs are impedance controlled. I_{OL} = (V_{DDQ}/2)/(RQ/5) for values of 175 ohms ≤ RQ ≤ 350 ohms.

26. The operation current is calculated with 50% read cycle and 50% write cycle.

Electrical Characteristics (continued)

Over the Operating Range

DC Electrical Characteristics (continued)

Over the Operating Range

Parameter ^[23]	Description	Test Conditions	Min	Typ	Max	Unit		
I _{SB1}	Automatic Power down Current	Max V _{DD} , Both Ports Deselected, V _{IN} ≥ V _{IH} or V _{IN} ≤ V _{IL} f = f _{MAX} = 1/t _{CYC} , Inputs Static	633 MHz	(× 18)	–	–	1165	mA
				(× 36)	–	–	1660	
			600 MHz	(× 18)	–	–	1100	mA
				(× 36)	–	–	1570	

AC Electrical Characteristics

Over the Operating Range

Parameter ^[27]	Description	Test Conditions	Min	Typ	Max	Unit
V _{IH}	Input HIGH voltage		V _{REF} + 0.2	–	V _{DDQ} + 0.24	V
V _{IL}	Input LOW voltage		–0.24	–	V _{REF} – 0.2	V

Capacitance

Parameter ^[28]	Description	Test Conditions	Max	Unit
C _{IN}	Input capacitance	T _A = 25 °C, f = 1 MHz, V _{DD} = 1.8 V, V _{DDQ} = 1.5 V	4	pF
C _O	Output capacitance		4	pF

Thermal Resistance

Parameter ^[28]	Description	Test Conditions	165-ball FBGA Package	Unit
Θ _{JA} (0 m/s)	Thermal resistance (junction to ambient)	Socketed on a 170 x 220 x 2.35 mm, eight-layer printed circuit board	14.43	°C/W
Θ _{JA} (1 m/s)			13.40	°C/W
Θ _{JA} (3 m/s)			12.66	°C/W
Θ _{JB}	Thermal resistance (junction to board)		11.38	°C/W
Θ _{JC}	Thermal resistance (junction to case)		3.30	°C/W

Notes

27. Overshoot: V_{IH(AC)} ≤ V_{DDQ} + 0.35 V (Pulse width less than t_{CYC}/2), Undershoot: V_{IL(AC)} ≥ –0.3 V (Pulse width less than t_{CYC}/2).

28. Tested initially and after any design or process change that may affect these parameters.

AC Test Loads and Waveforms

Figure 5. AC Test Loads and Waveforms

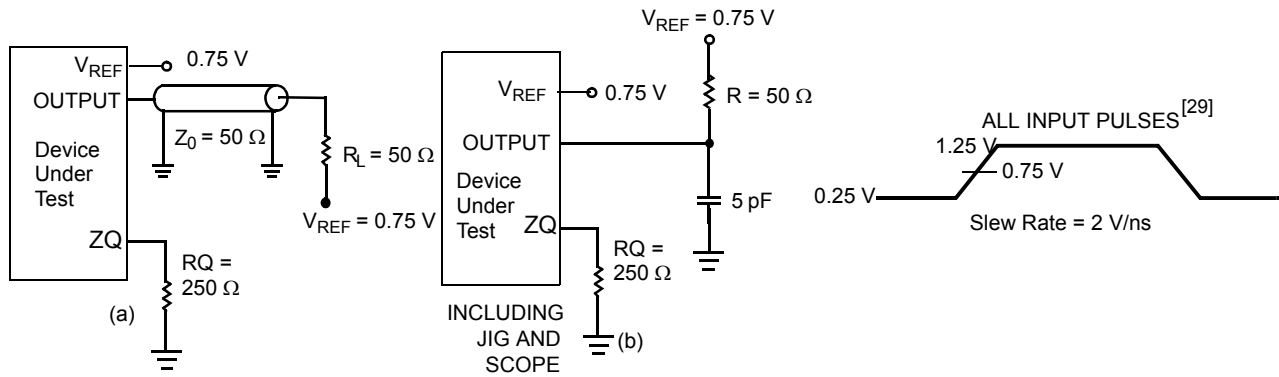

Note

29. Unless otherwise noted, test conditions are based on signal transition time of 2 V/ns, timing reference levels of 0.75 V, $V_{ref} = 0.75 \text{ V}$, $R_Q = 250 \Omega$, $V_{DDQ} = 1.5 \text{ V}$, input pulse levels of 0.25 V to 1.25 V, and output loading of the specified I_{OL}/I_{OH} and load capacitance shown in (a) of Figure 5.

Switching Characteristics

Over the Operating Range

Parameters ^[30, 31]		Description	633 MHz		600 MHz		Unit
Cypress Parameter	Consortium Parameter		Min	Max	Min	Max	
t _{POWER}		V _{DD} (Typical) to the First Access ^[32]	1	–	1	–	ms
t _{CYC}	t _{KHKH}	K Clock Cycle Time	1.58	8.4	1.66	8.4	ns
t _{KH}	t _{KHKL}	Input Clock (K/ \bar{K}) HIGH	0.4	–	0.4	–	ns
t _{KL}	t _{KLKH}	Input Clock (K/ \bar{K}) LOW	0.4	–	0.4	–	ns
t _{KH\bar{K}H}	t _{KH\bar{K}H}	K Clock Rise to \bar{K} Clock Rise (rising edge to rising edge)	0.71	–	0.75	–	ns
Setup Times							
t _{SA}	t _{AVKH}	Address Setup to K Clock Rise	0.23	–	0.23	–	ns
t _{SC}	t _{IVKH}	Control Setup to K Clock Rise (\overline{RPS} , \overline{WPS})	0.23	–	0.23	–	ns
t _{SCDDR}	t _{IVKH}	Double Data Rate Control Setup to Clock (K/ \bar{K}) Rise (\overline{BWS}_0 , \overline{BWS}_1 , \overline{BWS}_2 , \overline{BWS}_3)	0.18	–	0.18	–	ns
t _{SD}	t _{DVKH}	D _[X:0] Setup to Clock (K/ \bar{K}) Rise	0.18	–	0.18	–	ns
Hold Times							
t _{HA}	t _{KHAX}	Address Hold after K Clock Rise	0.23	–	0.23	–	ns
t _{HC}	t _{KHIX}	Control Hold after K Clock Rise (\overline{RPS} , \overline{WPS})	0.23	–	0.23	–	ns
t _{HCDDR}	t _{KHIX}	Double Data Rate Control Hold after Clock (K/ \bar{K}) Rise (\overline{BWS}_0 , \overline{BWS}_1 , \overline{BWS}_2 , \overline{BWS}_3)	0.18	–	0.18	–	ns
t _{HD}	t _{KHDX}	D _[X:0] Hold after Clock (K/ \bar{K}) Rise	0.18	–	0.18	–	ns
Output Times							
t _{CCQO}	t _{CHCQV}	K/ \bar{K} Clock Rise to Echo Clock Valid	–	0.45	–	0.45	ns
t _{CQOH}	t _{CHCQX}	Echo Clock Hold after K/ \bar{K} Clock Rise	–0.45	–	–0.45	–	ns
t _{CQD}	t _{CQHQV}	Echo Clock High to Data Valid		0.09		0.09	ns
t _{CQDOH}	t _{CQHQX}	Echo Clock High to Data Invalid	–0.09	–	–0.09	–	ns
t _{CQH}	t _{CQH\bar{C}Q}	Output Clock (CQ/ \bar{C} Q) HIGH ^[33]	0.71	–	0.75	–	ns
t _{CQH\bar{C}Q}	t _{CQH\bar{C}Q}	CQ Clock Rise to \bar{C} Q Clock Rise (rising edge to rising edge) ^[33]	0.71	–	0.75	–	ns
t _{CHZ}	t _{CHQZ}	Clock (K/ \bar{K}) Rise to High Z (Active to High Z) ^[34, 35]	–	0.45	–	0.45	ns
t _{CLZ}	t _{CHQX1}	Clock (K/ \bar{K}) Rise to Low Z ^[34, 35]	–0.45	–	–0.45	–	ns
t _{QVLD}	t _{CQH\bar{C}QVLD}	Echo Clock High to QVLD Valid ^[36]	–0.15	0.15	–0.15	0.15	ns
PLL Timing							
t _{KC Var}	t _{KC Var}	Clock Phase Jitter	–	0.15	–	0.15	ns
t _{KC lock}	t _{KC lock}	PLL Lock Time (K)	100	–	100	–	μs
t _{KC Reset}	t _{KC Reset}	K Static to PLL Reset ^[37]	30	–	30	–	ns

Notes

30. Unless otherwise noted, test conditions are based on signal transition time of 2 V/ns, timing reference levels of 0.75 V, V_{ref} = 0.75 V, R_Q = 250 Ω, V_{DDQ} = 1.5 V, input pulse levels of 0.25 V to 1.25 V, and output loading of the specified I_{OL}/I_{OH} and load capacitance shown in (a) of Figure 5 on page 23.
31. When a part with a maximum frequency above 600 MHz is operating at a lower clock frequency, it requires the input timings of the frequency range in which it is being operated and outputs data with the output timings of that frequency range.
32. This part has a voltage regulator internally; t_{POWER} is the time that the power must be supplied above V_{DD(minimum)} initially before a read or write operation can be initiated.
33. These parameters are extrapolated from the input timing parameters (t_{CYC}/2 – 80 ps, where 80 ps is the internal jitter). These parameters are only guaranteed by design and are not tested in production.
34. t_{CHZ}, t_{CLZ}, are specified with a load capacitance of 5 pF as in (b) of Figure 5 on page 23. Transition is measured ± 100 mV from steady-state voltage.
35. At any voltage and temperature t_{CHZ} is less than t_{CLZ}.
36. t_{QVLD} spec is applicable for both rising and falling edges of QVLD signal.
37. Hold to >V_{IH} or <V_{IL}.

Switching Waveforms

Read/Write/Deselect Sequence

Figure 6. Waveform for 2.5 Cycle Read Latency [38, 39, 40]

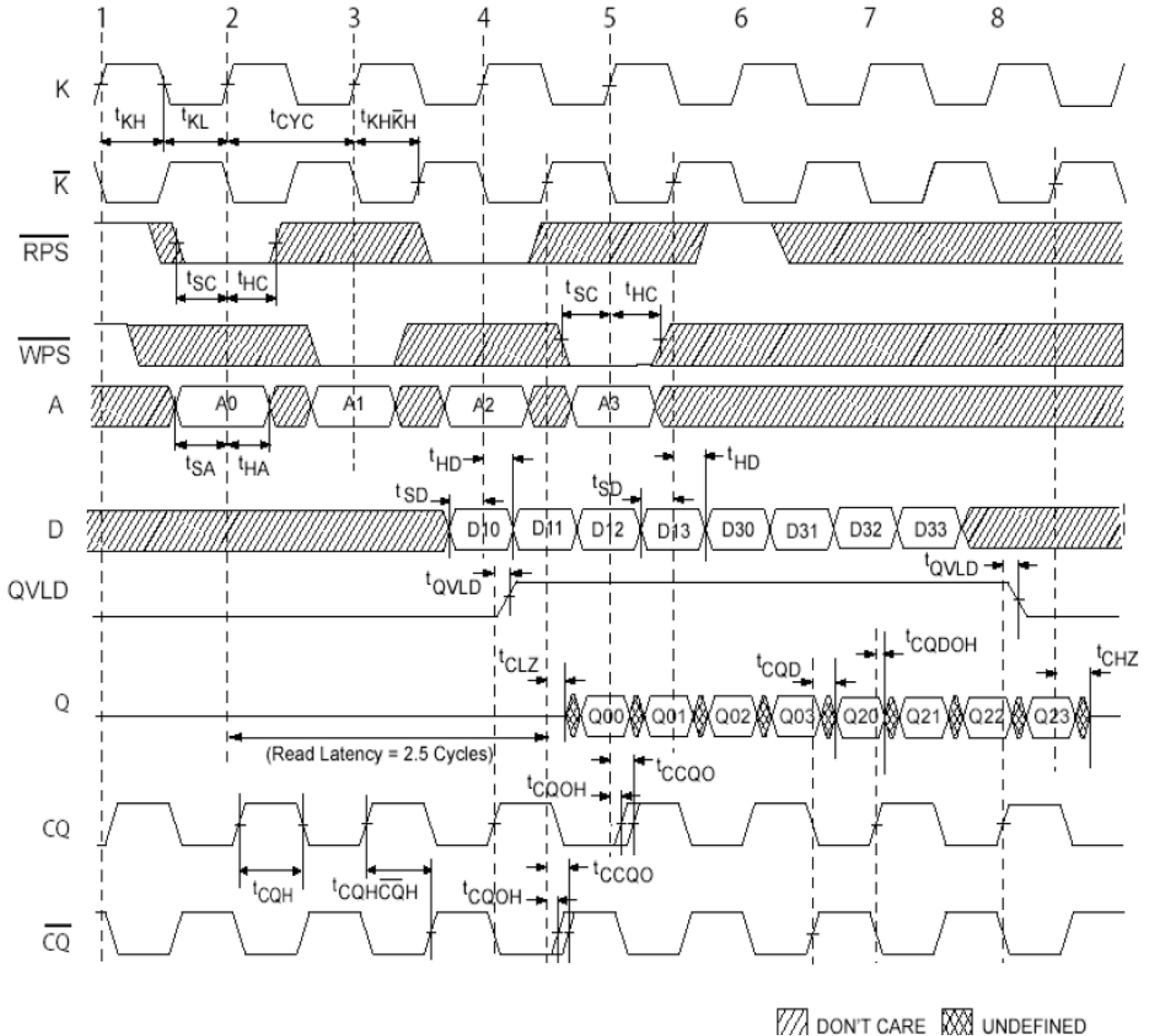

Notes

38. Q00 refers to output from address A0. Q01 refers to output from the next internal burst address following A0, that is, A0 + 1.

39. Outputs are disabled (High Z) one clock cycle after a NOP.

40. In this example, if address A2 = A1, then data Q20 = D10, Q21 = D11, Q22 = D12, and Q23 = D13. Write data is forwarded immediately as read results. This note applies to the whole diagram.