



Chipsmall Limited consists of a professional team with an average of over 10 year of expertise in the distribution of electronic components. Based in Hongkong, we have already established firm and mutual-benefit business relationships with customers from,Europe,America and south Asia,supplying obsolete and hard-to-find components to meet their specific needs.

With the principle of "Quality Parts,Customers Priority,Honest Operation,and Considerate Service",our business mainly focus on the distribution of electronic components. Line cards we deal with include Microchip,ALPS,ROHM,Xilinx,Pulse,ON,Everlight and Freescale. Main products comprise IC,Modules,Potentiometer,IC Socket,Relay,Connector.Our parts cover such applications as commercial,industrial, and automotives areas.

We are looking forward to setting up business relationship with you and hope to provide you with the best service and solution. Let us make a better world for our industry!



## Contact us

Tel: +86-755-8981 8866 Fax: +86-755-8427 6832

Email & Skype: info@chipsmall.com Web: www.chipsmall.com

Address: A1208, Overseas Decoration Building, #122 Zhenhua RD., Futian, Shenzhen, China





CYPRESS

CY7C375i

# UltraLogic™ 128-Macrocell Flash CPLD

## Features

- 128 macrocells in eight logic blocks
- 128 I/O pins
- 5 dedicated inputs including 4 clock pins
- In-System Reprogrammable (ISR™) Flash technology
  - JTAG Interface
- Bus Hold capabilities on all I/Os and dedicated inputs
- No hidden delays
- High speed
  - $f_{MAX} = 125$  MHz
  - $t_{PD} = 10$  ns
  - $t_S = 5.5$  ns
  - $t_{CO} = 6.5$  ns
- Fully PCI compliant
- 3.3V or 5.0V I/O operation
- Available in 160-pin TQFP, CQFP, and PGA packages

## Functional Description

The CY7C375i is an In-System Reprogrammable Complex Programmable Logic Device (CPLD) and is part of the FLASH370i™ family of high-density, high-speed CPLDs. Like all members of the FLASH370i family, the CY7C375i is designed to bring the ease of use and high performance of the 22V10 to high-density PLDs.

Like all of the UltraLogic™ FLASH370i devices, the CY7C375i is electrically erasable and In-System Reprogrammable (ISR), which simplifies both design and manufacturing flows thereby reducing costs. The Cypress ISR function is implemented through a JTAG serial interface. Data is shifted in and out through the SDI and SDO pins. The ISR interface is enabled using the programming voltage pin (ISR<sub>EN</sub>). Additionally, because of the superior routability of the FLASH370i devices, ISR often allows users to change existing logic designs while simultaneously fixing pinout assignments.

## Logic Block Diagram

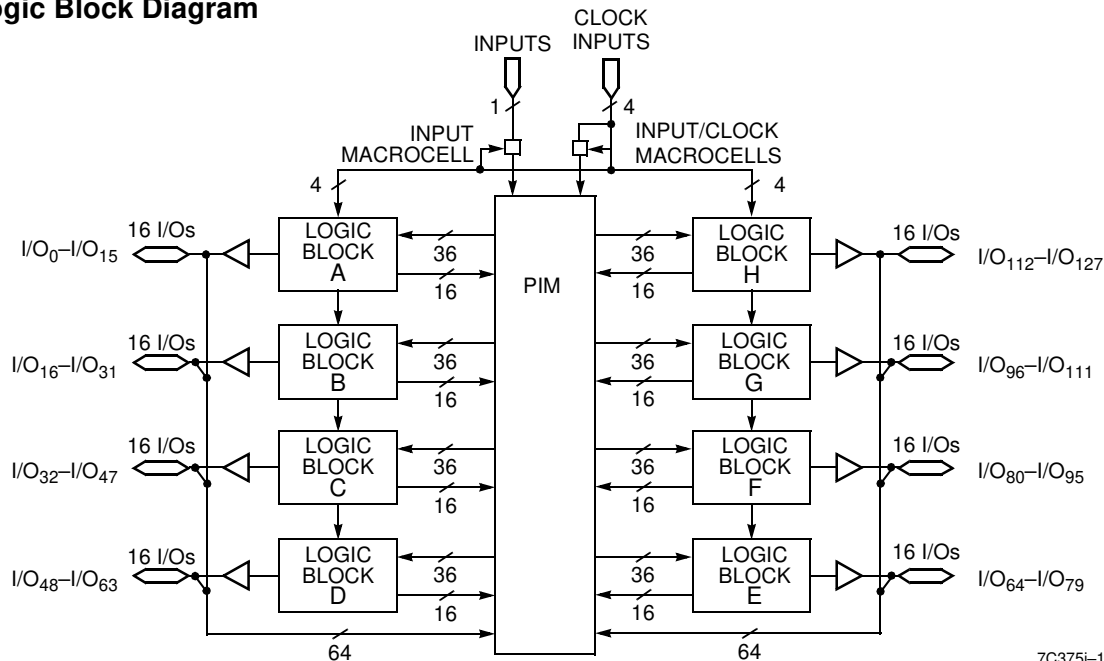

## Selection Guide

	7C375i-125	7C375i-100	7C375i-83	7C375iL-83	7C375i-66	7C375iL-66
Maximum Propagation Delay <sup>[1]</sup> , $t_{PD}$ (ns)	10	12	15	15	20	20
Minimum Set-Up, $t_S$ (ns)	5.5	6	8	8	10	10
Maximum Clock to Output <sup>[1]</sup> , $t_{CO}$ (ns)	6.5	7	8	8	10	10
Typical Supply Current, $I_{CC}$ (mA)	125	125	125	75	125	75

### Note:

1. The 3.3V I/O mode timing adder,  $t_{3.3IO}$ , must be added to this specification when  $V_{CCIO} = 3.3V$

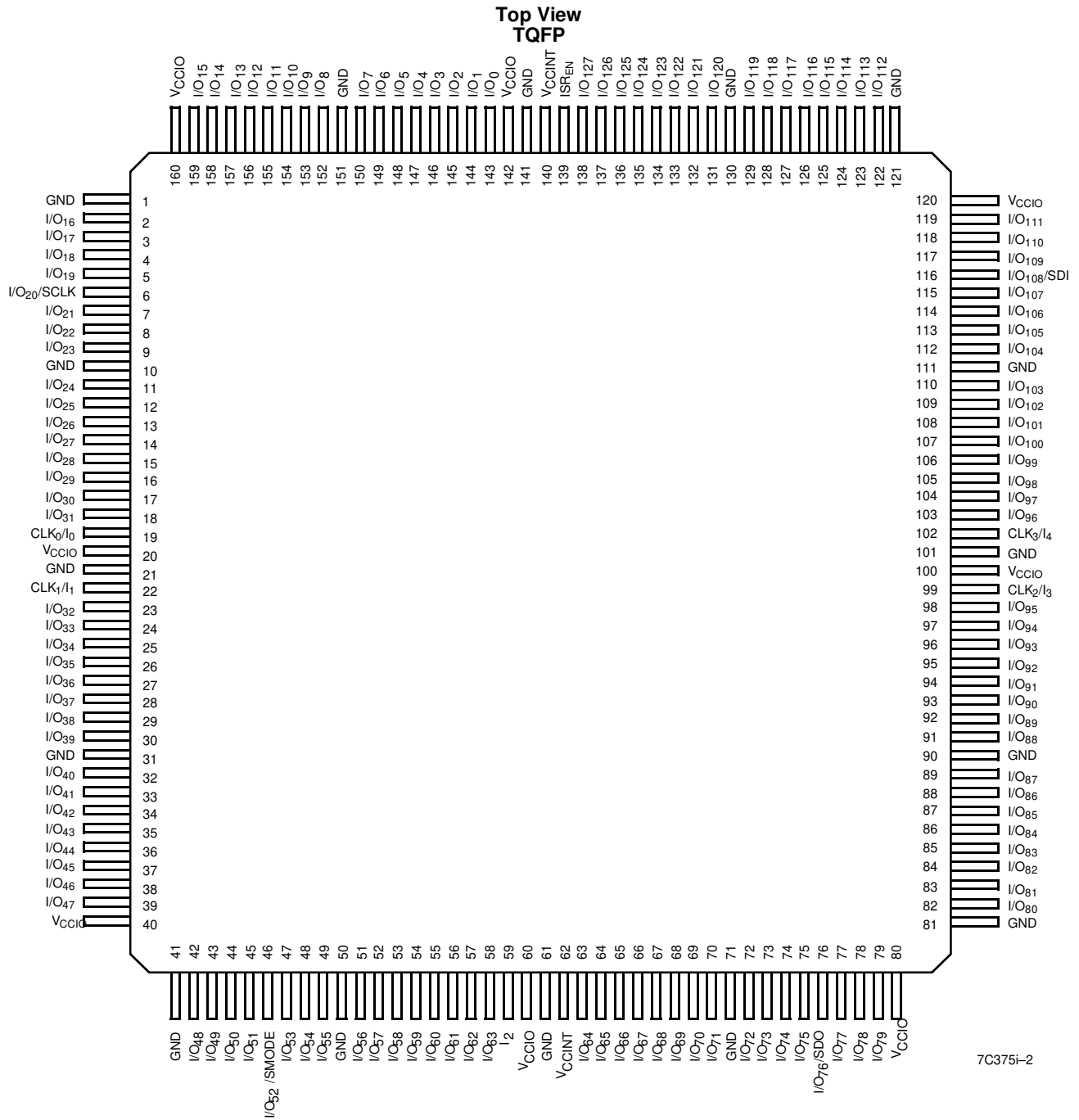
**Pin Configurations**

7C375i-2

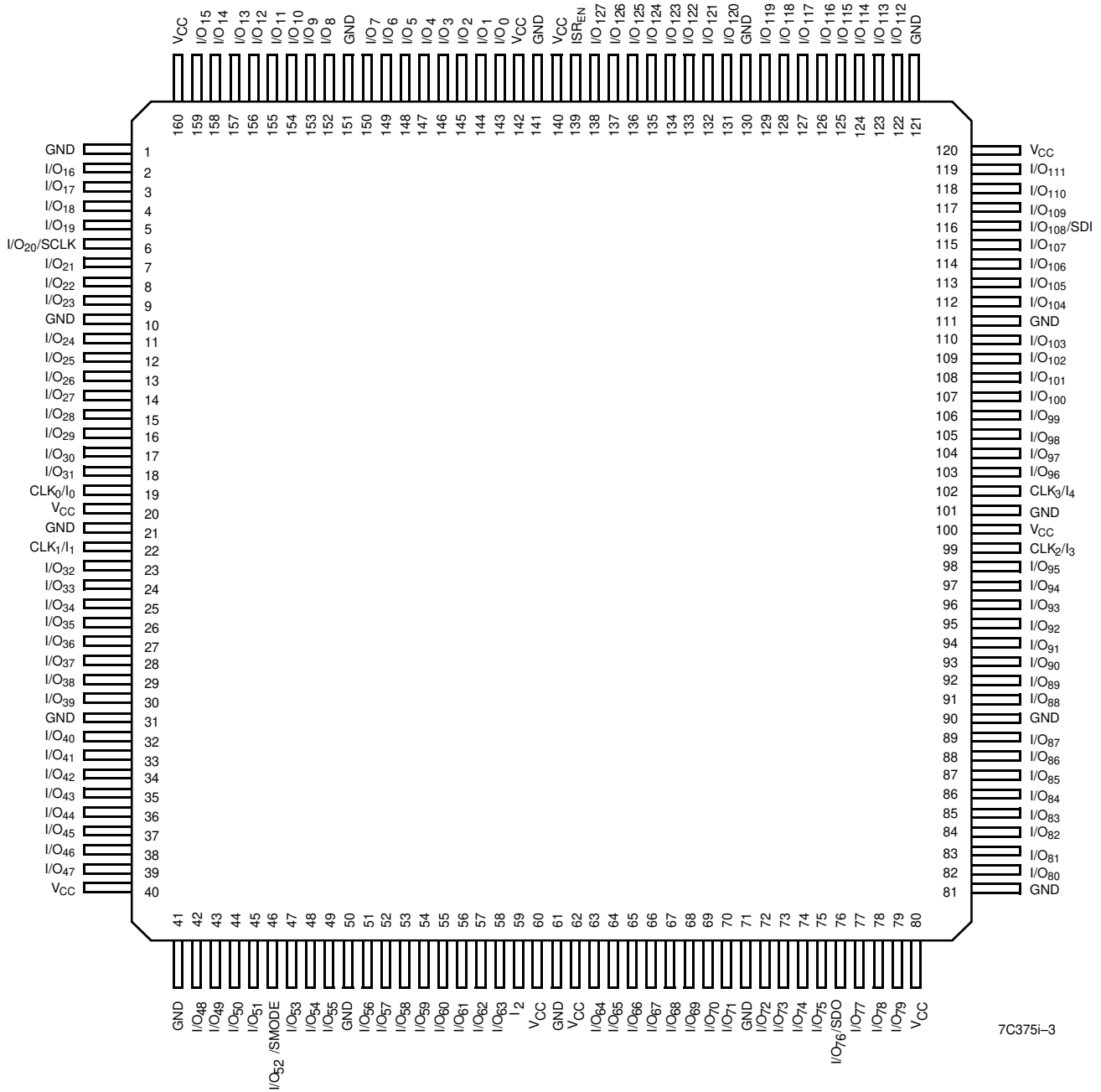
**Pin Configurations (continued)**
**Top View  
CQFP**

7C375i-3

**Pin Configurations** (continued)

**PGA  
Bottom View**

R	I/O <sub>109</sub>	I/O <sub>112</sub>	I/O <sub>115</sub>	I/O <sub>118</sub>	I/O <sub>121</sub>	I/O <sub>123</sub>	I/O <sub>126</sub>	I/O <sub>127</sub>	I/O <sub>0</sub>	I/O <sub>3</sub>	I/O <sub>5</sub>	I/O <sub>7</sub>	I/O <sub>10</sub>	I/O <sub>11</sub>	I/O <sub>14</sub>
P	I/O <sub>106</sub>	I/O <sub>110</sub>	I/O <sub>113</sub>	I/O <sub>116</sub>	I/O <sub>119</sub>	I/O <sub>122</sub>	I/O <sub>125</sub>	GND	I/O <sub>1</sub>	I/O <sub>4</sub>	I/O <sub>6</sub>	I/O <sub>9</sub>	I/O <sub>13</sub>	I/O <sub>15</sub>	I/O <sub>16</sub>
N	I/O <sub>105</sub>	I/O <sub>108</sub> /SDI	I/O <sub>111</sub>	I/O <sub>114</sub>	I/O <sub>117</sub>	I/O <sub>120</sub>	I/O <sub>124</sub>	ISR <sub>EN</sub>	I/O <sub>2</sub>	GND	I/O <sub>8</sub>	I/O <sub>12</sub>	GND	I/O <sub>17</sub>	I/O <sub>19</sub>
M	I/O <sub>102</sub>	I/O <sub>104</sub>	I/O <sub>107</sub>	V <sub>CC</sub>			V <sub>CC</sub>	GND	V <sub>CC</sub>			GND	I/O <sub>18</sub>	I/O <sub>20</sub> /SCLK	I/O <sub>22</sub>
L	I/O <sub>100</sub>	I/O <sub>101</sub>	I/O <sub>103</sub>										I/O <sub>21</sub>	I/O <sub>23</sub>	I/O <sub>25</sub>
K	I/O <sub>98</sub>	I/O <sub>99</sub>	GND										I/O <sub>24</sub>	I/O <sub>26</sub>	I/O <sub>27</sub>
J	I/O <sub>96</sub>	I/O <sub>97</sub>	CLK <sub>3</sub> /I <sub>4</sub>	V <sub>CC</sub>								V <sub>CC</sub>	CLK <sub>28</sub>	I/O <sub>29</sub>	I/O <sub>30</sub>
H	I/O <sub>95</sub>	GND	CLK <sub>2</sub> /I <sub>3</sub>	GND								GND	CLK <sub>0</sub> /I <sub>0</sub>	GND	I/O <sub>31</sub>
G	I/O <sub>94</sub>	I/O <sub>93</sub>	I/O <sub>92</sub>	V <sub>CC</sub>								V <sub>CC</sub>	CLK <sub>1</sub> /I <sub>1</sub>	I/O <sub>33</sub>	I/O <sub>32</sub>
F	I/O <sub>91</sub>	I/O <sub>90</sub>	I/O <sub>88</sub>										GND	I/O <sub>35</sub>	I/O <sub>34</sub>
E	I/O <sub>89</sub>	I/O <sub>87</sub>	I/O <sub>85</sub>		■								I/O <sub>39</sub>	I/O <sub>37</sub>	I/O <sub>36</sub>
D	I/O <sub>86</sub>	I/O <sub>84</sub>	I/O <sub>82</sub>	GND			V <sub>CC</sub>	GND	V <sub>CC</sub>			V <sub>CC</sub>	I/O <sub>43</sub>	I/O <sub>40</sub>	I/O <sub>38</sub>
C	I/O <sub>83</sub>	I/O <sub>81</sub>	GND	I/O <sub>76</sub> /SDO	I/O <sub>72</sub>	GND	I/O <sub>66</sub>	I <sub>2</sub>	I/O <sub>60</sub>	I/O <sub>56</sub>	I/O <sub>53</sub>	I/O <sub>50</sub>	I/O <sub>47</sub>	I/O <sub>44</sub>	I/O <sub>41</sub>
B	I/O <sub>80</sub>	I/O <sub>79</sub>	I/O <sub>77</sub>	I/O <sub>73</sub>	I/O <sub>70</sub>	I/O <sub>68</sub>	I/O <sub>65</sub>	GND	I/O <sub>61</sub>	I/O <sub>58</sub>	I/O <sub>55</sub>	I/O <sub>52</sub> /SMODE	I/O <sub>49</sub>	I/O <sub>46</sub>	I/O <sub>42</sub>
A	I/O <sub>78</sub>	I/O <sub>75</sub>	I/O <sub>74</sub>	I/O <sub>71</sub>	I/O <sub>69</sub>	I/O <sub>67</sub>	I/O <sub>64</sub>	I/O <sub>63</sub>	I/O <sub>62</sub>	I/O <sub>59</sub>	I/O <sub>57</sub>	I/O <sub>51</sub>	I/O <sub>48</sub>	I/O <sub>45</sub>	
	1	2	3	4	5	6	7	8	9	10	11	12	13	14	15

7C375i-4

**Functional Description** (continued)

The 128 macrocells in the CY7C375i are divided between eight logic blocks. Each logic block includes 16 macrocells, a 72 x 86 product term array, and an intelligent product term allocator.

The logic blocks in the FLASH370i architecture are connected with an extremely fast and predictable routing resource—the Programmable Interconnect Matrix (PIM). The PIM brings flexibility, routability, speed, and a uniform delay to the interconnect.

Like all members of the FLASH370i family, the CY7C375i is rich in I/O resources. Every macrocell in the device features an associated I/O pin, resulting in 128 I/O pins on the CY7C375i. In addition, there is one dedicated input and four input/clock pins.

Finally, the CY7C375i features a very simple timing model. Unlike other high-density CPLD architectures, there are no hidden speed delays such as fanout effects, interconnect delays, or expander delays. Regardless of the number of resources used or the type of application, the timing parameters on the CY7C375i remain the same.

**Logic Block**

The number of logic blocks distinguishes the members of the FLASH370i family. The CY7C375i includes eight logic blocks. Each logic block is constructed of a product term array, a product term allocator, and 16 macrocells.

*Product Term Array*

The product term array in the FLASH370i logic block includes 36 inputs from the PIM and outputs 86 product terms to the product term allocator. The 36 inputs from the PIM are available in both positive and negative polarity, making the overall array size 72 x 86. This large array in each logic block allows for very complex functions to be implemented in single passes through the device.

*Product Term Allocator*

The product term allocator is a dynamic, configurable resource that shifts product terms to macrocells that require them. Any number of product terms between 0 and 16 inclusive can be assigned to any of the logic block macrocells (this is called product term steering). Furthermore, product terms can be shared among multiple macrocells. This means that product terms that are common to more than one output can be imple-

mented in a single product term. Product term steering and product term sharing help to increase the effective density of the FLASH370i PLDs. Note that product term allocation is handled by software and is invisible to the user.

#### I/O Macrocell

Each of the macrocells on the CY7C375i has a separate I/O pin associated with it. The input to the macrocell is the sum of between 0 and 16 product terms from the product term allocator. The macrocell includes a register that can be optionally bypassed, polarity control over the input sum-term, and four global clocks to trigger the register. The macrocell also features a separate feedback path to the PIM so that the register can be buried if the I/O pin is used as an input.

#### Programmable Interconnect Matrix

The Programmable Interconnect Matrix (PIM) connects the eight logic blocks on the CY7C375i to the inputs and to each other. All inputs (including feedbacks) travel through the PIM. There is no speed penalty incurred by signals traversing the PIM.

#### Programming

For an overview of ISR programming, refer to the FLASH370i Family data sheet and for ISR cable and software specifications, refer to ISR data sheets. For a detailed description of ISR capabilities, refer to the Cypress application note, "An Introduction to In System Reprogramming with FLASH370i."

#### PCI Compliance

The FLASH370i family of CMOS CPLDs are fully compliant with the PCI Local Bus Specification published by the PCI Special Interest Group. The simple and predictable timing model of FLASH370i ensures compliance with the PCI AC specifications independent of the design. On the other hand, in CPLD and FPGA architectures without simple and predictable timing, PCI compliance is dependent upon routing and product term distribution.

#### 3.3V or 5.0V I/O operation

The FLASH370i family can be configured to operate in both 3.3V and 5.0V systems. All devices have two sets of  $V_{CC}$  pins: one set,  $V_{CCINT}$ , for internal operation and input buffers, and another set,  $V_{CCIO}$ , for I/O output drivers.  $V_{CCINT}$  pins must always be connected to a 5.0V power supply. However, the  $V_{CCIO}$  pins may be connected to either a 3.3V or 5.0V power supply, depending on the output requirements. When  $V_{CCIO}$  pins are connected to a 5.0V source, the I/O voltage levels are

compatible with 5.0V systems. When  $V_{CCIO}$  pins are connected to a 3.3V source, the input voltage levels are compatible with both 5.0V and 3.3V systems, while the output voltage levels are compatible with 3.3V systems. There will be an additional timing delay on all output buffers when operating in 3.3V I/O mode. The added flexibility of 3.3V I/O capability is available in commercial and industrial temperature ranges.

#### Bus Hold Capabilities on all I/Os and Dedicated Inputs

In addition to ISR capability, a new feature called bus-hold has been added to all FLASH370i I/Os and dedicated input pins. Bus-hold, which is an improved version of the popular internal pull-up resistor, is a weak latch connected to the pin that does not degrade the device's performance. As a latch, bus-hold recalls the last state of a pin when it is three-stated, thus reducing system noise in bus-interface applications. Bus-hold additionally allows unused device pins to remain unconnected on the board, which is particularly useful during prototyping as designers can route new signals to the device without cutting trace connections to  $V_{CC}$  or GND.

#### Design Tools

Development software for the CY7C375i is available from Cypress's *Warp™*, *Warp Professional™*, and *Warp Enterprise™* software packages. Please refer to the data sheets on these products for more details. Cypress also actively supports almost all third-party design tools. Please refer to third-party tool support for further information.

#### Maximum Ratings

(Above which the useful life may be impaired. For user guidelines, not tested.)

Storage Temperature .....	-65°C to +150°C
Ambient Temperature with Power Applied .....	-55°C to +125°C
Supply Voltage to Ground Potential .....	-0.5V to +7.0V
DC Voltage Applied to Outputs in High Z State.....	-0.5V to +7.0V
DC Input Voltage .....	-0.5V to +7.0V
DC Program Voltage .....	12.5V
Output Current into Outputs .....	16 mA
Static Discharge Voltage .....	>2001V (per MIL-STD-883, Method 3015)
Latch-Up Current.....	>200 mA

#### Operating Range

Range	Ambient Temperature	$V_{CC}$ $V_{CCINT}$	$V_{CCIO}$
Commercial	0°C to +70°C	5V ± 0.25V	5V ± 0.25V OR 3.3V ± 0.3V
Industrial	-40°C to +85°C	5V ± 0.5V	5V ± 0.5V OR 3.3V ± 0.3V
Military <sup>[2]</sup>	-55°C to +125°C	5V ± 0.5V	

**Note:**

2.  $T_A$  is the "instant on" case temperature.

**Electrical Characteristics** Over the Operating Range<sup>[3, 4]</sup>

Parameter	Description	Test Conditions		Min.	Typ.	Max.	Unit
V <sub>OH</sub>	Output HIGH Voltage	V <sub>CC</sub> = Min.	I <sub>OH</sub> = -3.2 mA (Com'l/Ind) <sup>[5]</sup>	2.4			V
			I <sub>OH</sub> = -2.0 mA (Mil)				V
V <sub>OHZ</sub>	Output HIGH Voltage with Output Disabled <sup>[9]</sup>	V <sub>CC</sub> = Max.	I <sub>OH</sub> = 0 μA (Com'l/Ind) <sup>[5, 6]</sup>			4.0	V
			I <sub>OH</sub> = -50 μA (Com'l/Ind) <sup>[5, 6]</sup>				V
V <sub>OL</sub>	Output LOW Voltage	V <sub>CC</sub> = Min.	I <sub>OL</sub> = 16 mA (Com'l/Ind) <sup>[5]</sup>			0.5	V
			I <sub>OL</sub> = 12 mA (Mil)				V
V <sub>IH</sub>	Input HIGH Voltage	Guaranteed Input Logical HIGH voltage for all inputs <sup>[7]</sup>		2.0		7.0	V
V <sub>IL</sub>	Input LOW Voltage	Guaranteed Input Logical LOW voltage for all inputs <sup>[7]</sup>		-0.5		0.8	V
I <sub>IX</sub>	Input Load Current	V <sub>I</sub> = Internal GND, V <sub>I</sub> = V <sub>CC</sub>		-10		+10	μA
I <sub>OZ</sub>	Output Leakage Current	V <sub>CC</sub> = Max., V <sub>O</sub> = GND or V <sub>O</sub> = V <sub>CC</sub> , Output Disabled		-50		+50	μA
		V <sub>CC</sub> = Max., V <sub>O</sub> = 3.3V, Output Disabled <sup>[6]</sup>		0	-70	-125	μA
I <sub>OS</sub>	Output Short Circuit Current <sup>[8, 9]</sup>	V <sub>CC</sub> = Max., V <sub>OUT</sub> = 0.5V		-30		-160	mA
I <sub>CC</sub>	Power Supply Current <sup>[10]</sup>	V <sub>CC</sub> = Max., I <sub>OUT</sub> = 0 mA, f = 1 MHz, V <sub>IN</sub> = GND, V <sub>CC</sub>	Com'l/Ind.		125	200	mA
			Com'l "L" -66		75	125	mA
			Military		125	250	mA
I <sub>BHL</sub>	Input Bus Hold LOW Sustaining Current	V <sub>CC</sub> = Min., V <sub>IL</sub> = 0.8V		+75			μA
I <sub>BHH</sub>	Input Bus Hold HIGH Sustaining Current	V <sub>CC</sub> = Min., V <sub>IH</sub> = 2.0V		-75			μA
I <sub>BHLO</sub>	Input Bus Hold LOW Overdrive Current	V <sub>CC</sub> = Max.				+500	μA
I <sub>BHHO</sub>	Input Bus Hold HIGH Overdrive Current	V <sub>CC</sub> = Max.				-500	μA

**Capacitance<sup>[9]</sup>**

Parameter	Description	Test Conditions	Min.	Max.	Unit
C <sub>I/O</sub> <sup>[11]</sup>	Input/Output Capacitance	V <sub>IN</sub> = 5.0V at f=1 MHz		8	pF
C <sub>CLK</sub>	Clock Signal Capacitance	V <sub>IN</sub> = 5.0V at f = 1 MHz	5	12	pF

**Notes:**

- See the last page of this specification for Group A subgroup testing information.
- If V<sub>CCIO</sub> is not specified, the device can be operating in either 3.3V or 5V I/O mode; V<sub>CC</sub>=V<sub>CCINT</sub>.
- I<sub>OH</sub> = -2 mA, I<sub>OL</sub> = 2 mA for SDO.
- When the I/O is three-stated, the bus-hold circuit can weakly pull the I/O to a maximum of 4.0V if no leakage current is allowed. This voltage is lowered significantly by a small leakage current. Note that all I/Os are three-stated during ISR programming. Refer to the application note "Understanding Bus Hold" for additional information.
- These are absolute values with respect to device ground. All overshoots due to system or tester noise are included.
- Not more than one output should be tested at a time. Duration of the short circuit should not exceed 1 second. V<sub>OUT</sub> = 0.5V has been chosen to avoid test problems caused by tester ground degradation.
- Tested initially and after any design or process changes that may affect these parameters.
- Measured with 16-bit counter programmed into each logic block.
- C<sub>I/O</sub> for dedicated inputs, and for I/O pins with JTAG functionality is 12 pF, and for the ISR<sub>EN</sub> pin is 15 pF Max.

**Inductance<sup>[9]</sup>**

Parameter	Description	Test Conditions	160-Lead TQFP	160-Pin CQFP	160-Pin CPGA	Unit
L	Maximum Pin Inductance	$V_{IN} = 5.0V$ at $f = 1$ MHz	9	6	10	nH

**Endurance Characteristics<sup>[9]</sup>**

Parameter	Description	Test Conditions	Max.	Unit
N	Maximum Reprogramming Cycles	Normal Programming Conditions	100	Cycles

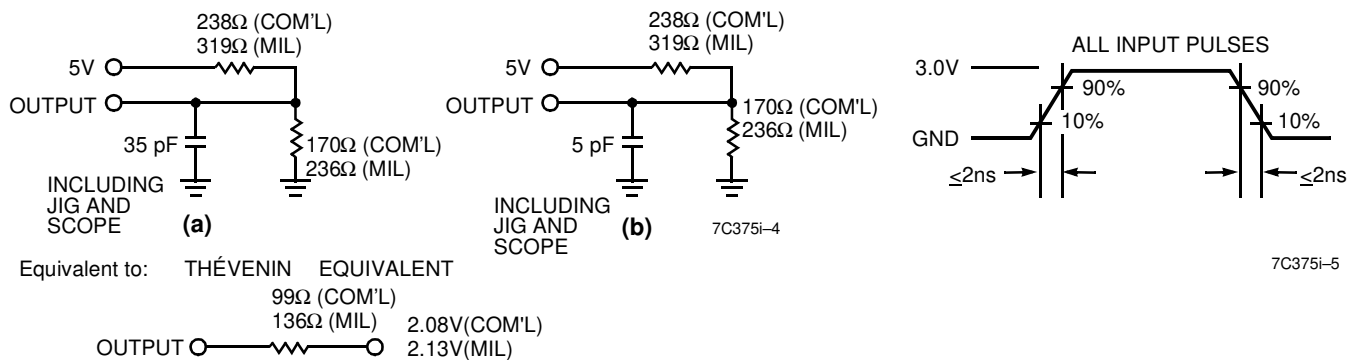
**AC Test Loads and Waveforms**

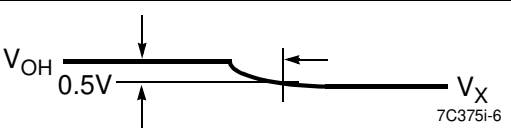
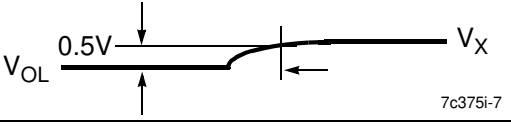
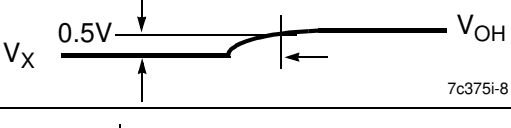
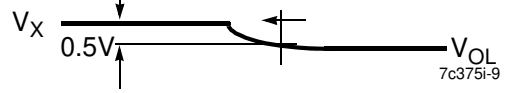
Parameter <sup>[12]</sup>	$V_X$	Output Waveforms--Measurement Level
$t_{ER(-)}$	1.5V	
$t_{ER(+)}$	2.6V	
$t_{EA(+)}$	1.5V	
$t_{EA(-)}$	$V_{the}$	

**(d) Test Waveforms**
**Note:**

12.  $t_{ER}$  measured with 5-pF AC Test Load and  $t_{EA}$  measured with 35-pF AC Test Load.



**Switching Characteristics** Over the Operating Range<sup>[13]</sup>

Parameter	Description	7C375i-125		7C375i-100		7C375i-83 7C374iL-83		7C375i-66 7C375iL-66		Unit
		Min.	Max.	Min.	Max.	Min.	Max.	Min.	Max.	
<b>Combinatorial Mode Parameters</b>										
t <sub>PD</sub>	Input to Combinatorial Output <sup>[1]</sup>		10		12		15		20	ns
t <sub>PDL</sub>	Input to Output Through Transparent Input or Output Latch <sup>[1]</sup>		13		15		18		22	ns
t <sub>PDLL</sub>	Input to Output Through Transparent Input and Output Latches <sup>[1]</sup>		15		16		19		24	ns
t <sub>EA</sub>	Input to Output Enable <sup>[1]</sup>		14		16		19		24	ns
t <sub>ER</sub>	Input to Output Disable		14		16		19		24	ns
<b>Input Registered/Latched Mode Parameters</b>										
t <sub>WL</sub>	Clock or Latch Enable Input LOW Time <sup>[9]</sup>	3		3		4		5		ns
t <sub>WH</sub>	Clock or Latch Enable Input HIGH Time <sup>[9]</sup>	3		3		4		5		ns
t <sub>IS</sub>	Input Register or Latch Set-Up Time	2		2		3		4		ns
t <sub>IH</sub>	Input Register or Latch Hold Time	2		2		3		4		ns
t <sub>ICO</sub>	Input Register Clock or Latch Enable to Combinatorial Output <sup>[1]</sup>		14		16		19		24	ns
t <sub>ICOL</sub>	Input Register Clock or Latch Enable to Output Through Transparent Output Latch <sup>[1]</sup>		16		18		21		26	ns
<b>Output Registered/Latched Mode Parameters</b>										
t <sub>CO</sub>	Clock or Latch Enable to Output <sup>[1]</sup>		6.5		7		8		10	ns
t <sub>S</sub>	Set-Up Time from Input to Clock or Latch Enable	5.5		6		8		10		ns
t <sub>H</sub>	Register or Latch Data Hold Time	0		0		0		0		ns
t <sub>CO2</sub>	Output Clock or Latch Enable to Output Delay (Through Memory Array) <sup>[1]</sup>		14		16		19		24	ns
t <sub>SCS</sub>	Output Clock or Latch Enable to Output Clock or Latch Enable (Through Memory Array)	8		10		12		15		ns
t <sub>SL</sub>	Set-Up Time from Input Through Transparent Latch to Output Register Clock or Latch Enable	10		12		15		20		ns
t <sub>HL</sub>	Hold Time for Input Through Transparent Latch from Output Register Clock or Latch Enable	0		0		0		0		ns
f <sub>MAX1</sub>	Maximum Frequency with Internal Feedback (Least of 1/t <sub>SCS</sub> , 1/(t <sub>S</sub> + t <sub>H</sub> ), or 1/t <sub>CO</sub> ) <sup>[9]</sup>	125		100		83		66		MHz
f <sub>MAX2</sub>	Maximum Frequency Data Path in Output Registered/Latched Mode (Lesser of 1/(t <sub>WL</sub> + t <sub>WH</sub> ), 1/(t <sub>S</sub> + t <sub>H</sub> ), or 1/t <sub>CO</sub> )	158.3		143		125		100		MHz
f <sub>MAX3</sub>	Maximum Frequency with External Feedback (Lesser of 1/(t <sub>CO</sub> + t <sub>S</sub> ) and 1/(t <sub>WL</sub> + t <sub>WH</sub> ).	83.3		76.9		62.5		50		MHz
t <sub>OH</sub> -t <sub>IH</sub> 37x	Output Data Stable from Output Clock Minus Input Register Hold Time for 7C37x <sup>[9, 14]</sup>	0		0		0		0		ns

**Notes:**

13. All AC parameters are measured with 16 outputs switching and 35-pF AC Test Load.
14. This specification is intended to guarantee interface compatibility of the other members of the CY7C370i family with the CY7C375i. This specification is met for the devices operating at the same ambient temperature and at the same power supply voltage.

**Switching Characteristics** Over the Operating Range<sup>[13]</sup> (continued)

Parameter	Description	7C375i-125		7C375i-100		7C375i-83 7C374iL-83		7C375i-66 7C375iL-66		Unit
		Min.	Max.	Min.	Max.	Min.	Max.	Min.	Max.	
<b>Pipelined Mode Parameters</b>										
$t_{ICS}$	Input Register Clock to Output Register Clock	8		10		12		15		ns
$f_{MAX4}$	Maximum Frequency in Pipelined Mode (Least of $1/(t_{CO} + t_{IS})$ , $1/t_{ICS}$ , $1/(t_{WL} + t_{WH})$ , $1/(t_{IS} + t_{IH})$ , or $1/t_{SCS}$ )	125		100		83.3		66.6		MHz
<b>Reset/Preset Parameters</b>										
$t_{RW}$	Asynchronous Reset Width <sup>[9]</sup>	10		12		15		20		ns
$t_{RR}$	Asynchronous Reset Recovery Time <sup>[9]</sup>	12		14		17		22		ns
$t_{RO}$	Asynchronous Reset to Output <sup>[1]</sup>		16		18		21		26	ns
$t_{PW}$	Asynchronous Preset Width <sup>[9]</sup>	10		12		15		20		ns
$t_{PR}$	Asynchronous Preset Recovery Time <sup>[9]</sup>	12		14		17		22		ns
$t_{PO}$	Asynchronous Preset to Output <sup>[1]</sup>		16		18		21		26	ns
<b>Tap Controller Parameter</b>										
$f_{TAP}$	Tap Controller Frequency	500		500		500		500		kHz
<b>3.3V I/O Mode Parameters</b>										
$t_{3.3IO}$	3.3V I/O mode timing adder		1		1		1		1	ns

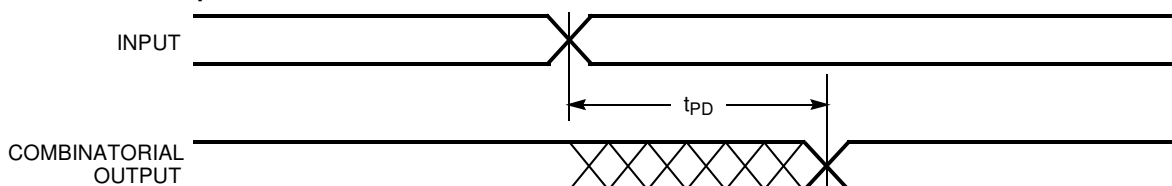
**Switching Waveforms**
**Combinatorial Output**

7C375i-10

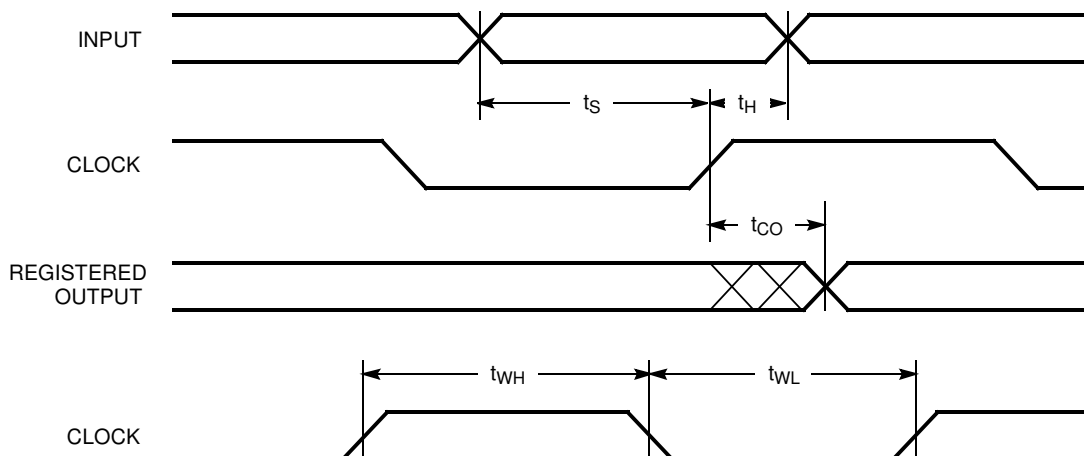
**Registered Output**

7C375i-11

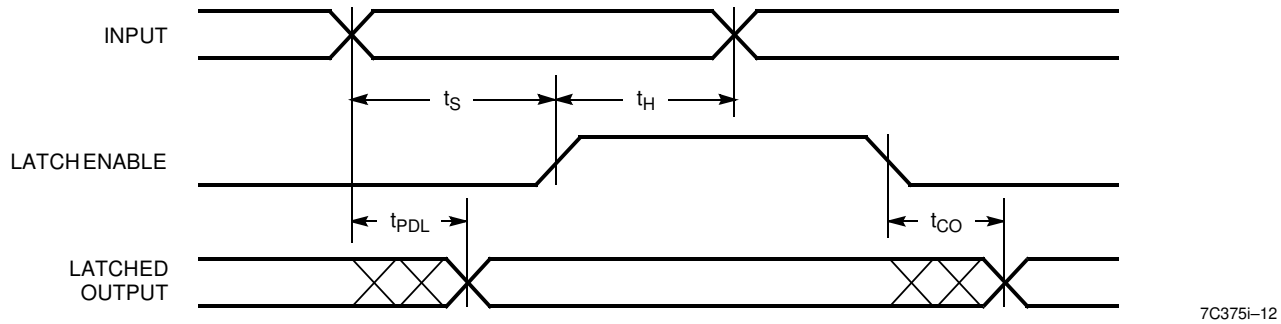
**Switching Waveforms (continued)**
**Latched Output**

7C375i-12

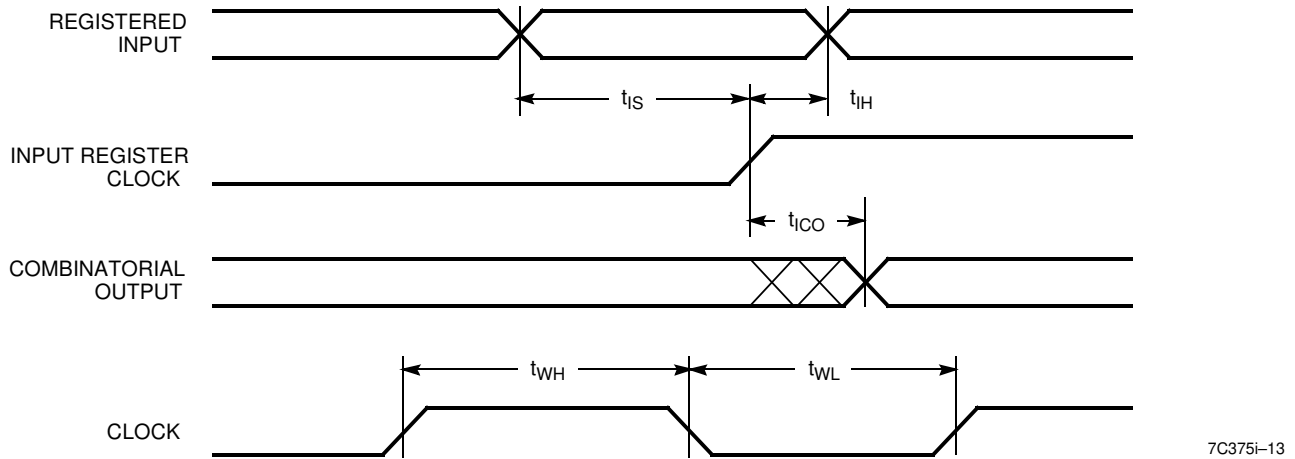
**Registered Input**

7C375i-13

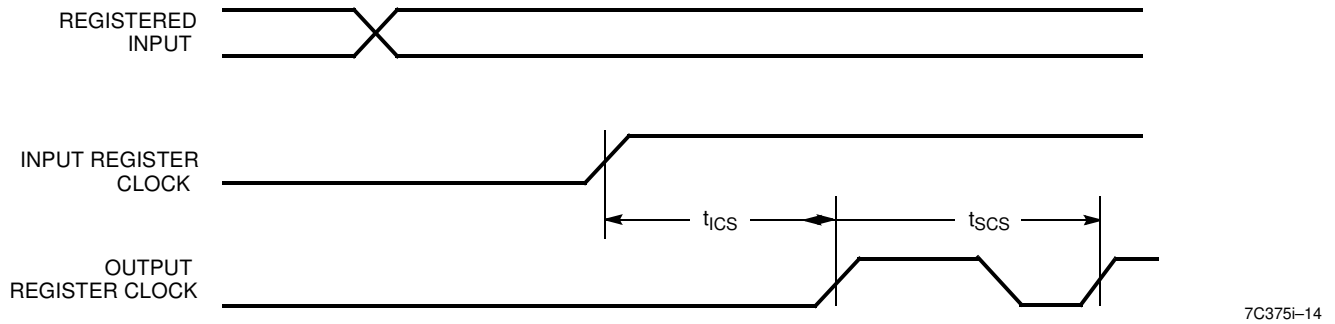
**Clock to Clock**

7C375i-14

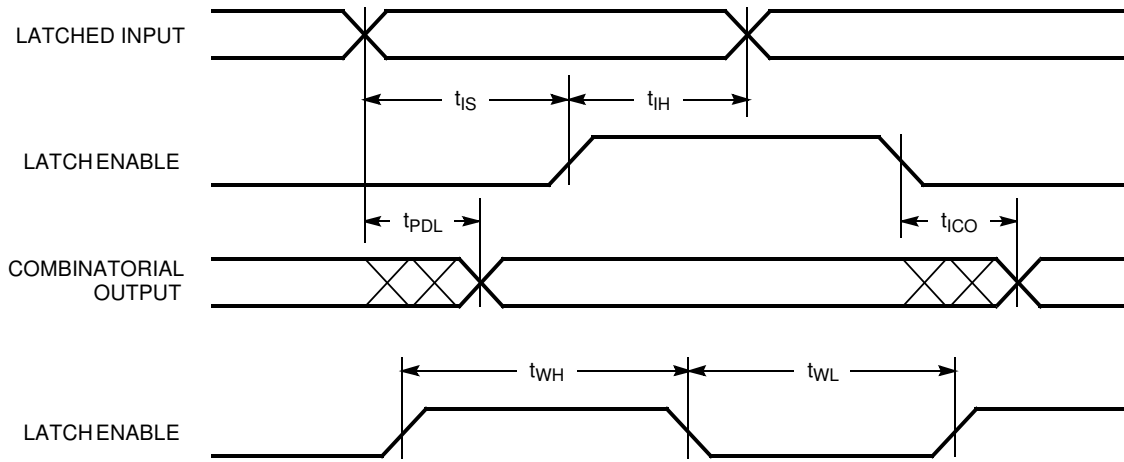
**Switching Waveforms (continued)**
**Latched Input**

7C375i-15

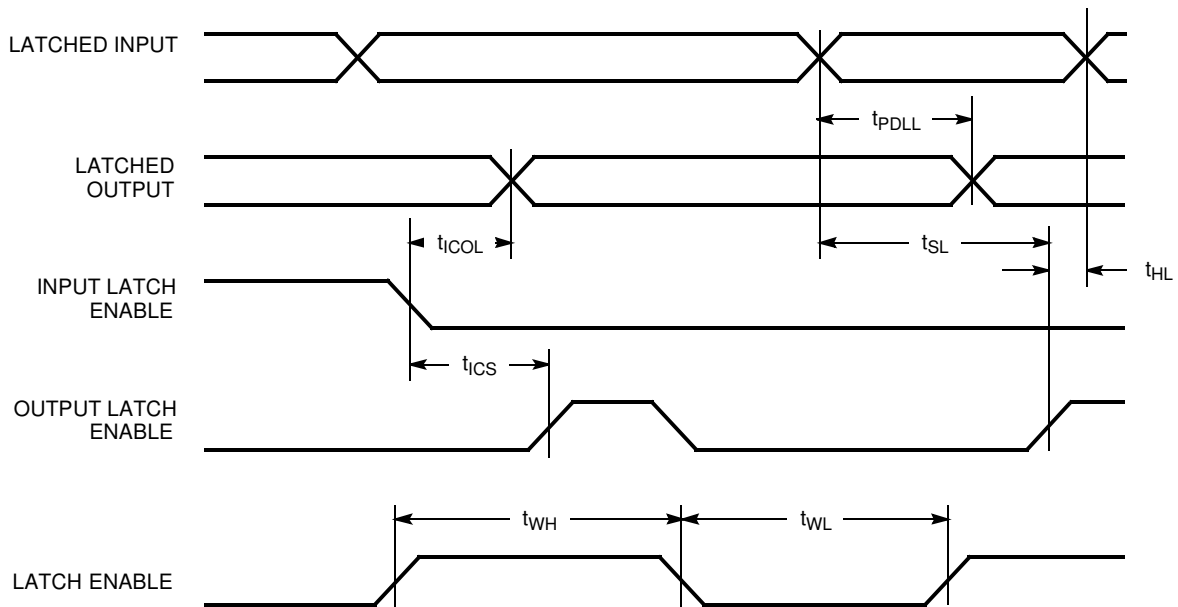
**Latched Input and Output**

7C375i-16

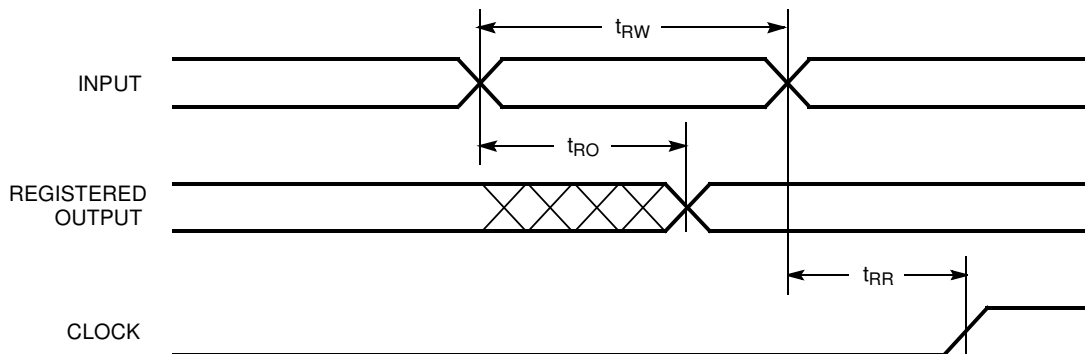
**Switching Waveforms (continued)**
**Asynchronous Reset**

7C375i-17

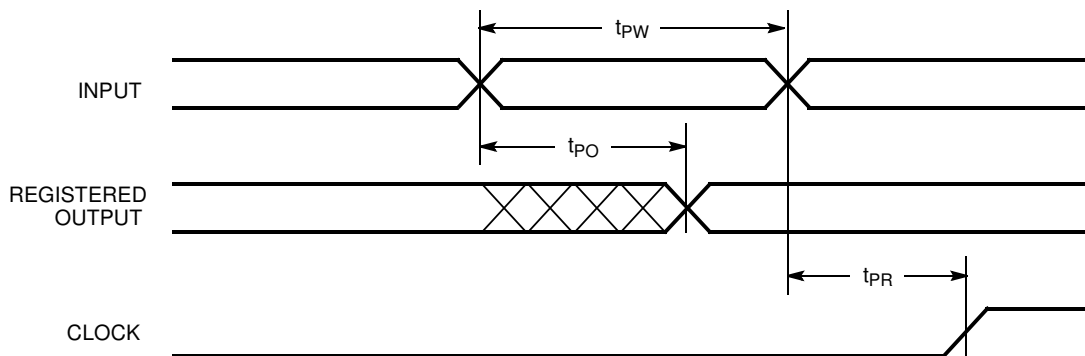
**Asynchronous Preset**

7C375i-18

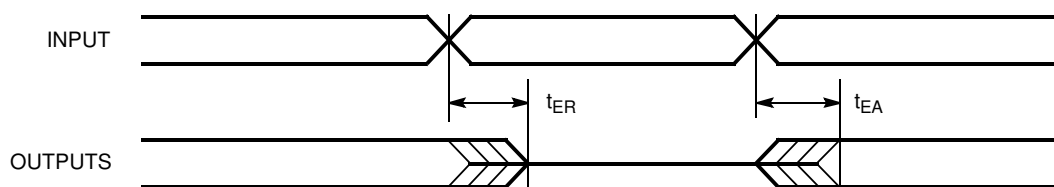
**Output Enable/Disable**

7C375i-20

**Ordering Information**

Speed (MHz)	Ordering Code	Package Name	Package Type	Operating Range
125	CY7C375i-125AC	A160	160-Lead Thin Quad Flatpack	Commercial
100	CY7C375i-100AC	A160	160-Lead Thin Quad Flatpack	Commercial
	CY7C375i-100AI	A160	160-Lead Thin Quad Flatpack	Industrial
83	CY7C375i-83AC	A160	160-Lead Thin Quad Flatpack	Commercial
	CY7C375i-83AI	A160	160-Lead Thin Quad Flatpack	Industrial
	CY7C375i-83GMB	G160	160-Pin Grid Array	Military
	CY7C375i-83UMB	U162	160-Pin Ceramic Quad Flatpack <sup>[15]</sup>	
	CY7C375iL-83AC	A160	160-Lead Thin Quad Flatpack	Commercial
66	CY7C375i-66AC	A160	160-Lead Thin Quad Flatpack	Commercial
	CY7C375i-66AI	A160	160-Lead Thin Quad Flatpack	Industrial
	CY7C375i-66GMB	G160	160-Pin Grid Array	Military
	CY7C375i-66UMB	U162	160-Pin Ceramic Quad Flatpack <sup>[15]</sup>	
	CY7C375iL-66AC	A160	160-Lead Thin Quad Flatpack	Commercial

**MILITARY SPECIFICATIONS**
**Group A Subgroup Testing**
**DC Characteristics**

Parameter	Subgroups
V <sub>OH</sub>	1, 2, 3
V <sub>OL</sub>	1, 2, 3
V <sub>IH</sub>	1, 2, 3
V <sub>IL</sub>	1, 2, 3
I <sub>Ix</sub>	1, 2, 3
I <sub>OZ</sub>	1, 2, 3
I <sub>CC</sub>	1, 2, 3

**Switching Characteristics**

Parameter	Subgroups
t <sub>PD</sub>	9, 10, 11
t <sub>CO</sub>	9, 10, 11
t <sub>ICO</sub>	9, 10, 11
t <sub>S</sub>	9, 10, 11
t <sub>H</sub>	9, 10, 11
t <sub>IS</sub>	9, 10, 11
t <sub>IH</sub>	9, 10, 11
t <sub>ICS</sub>	9, 10, 11

**Note:**

15. Standard product ships trim and formed in a carrier. This product is also available in a molded carrier ring. Contact local Cypress office for package information.

ISR, UltraLogic, FLASH370 and FLASH370i are trademarks of Cypress Semiconductor Corporation.  
*Warp*, *Warp Professional*, and *Warp Enterprise* are registered trademarks of Cypress Semiconductor Corporation.

Package Diagrams

160-Pin Thin Plastic Quad Flat Pack (TQFP) A160

DIMENSIONS ARE IN MILLIMETERS.

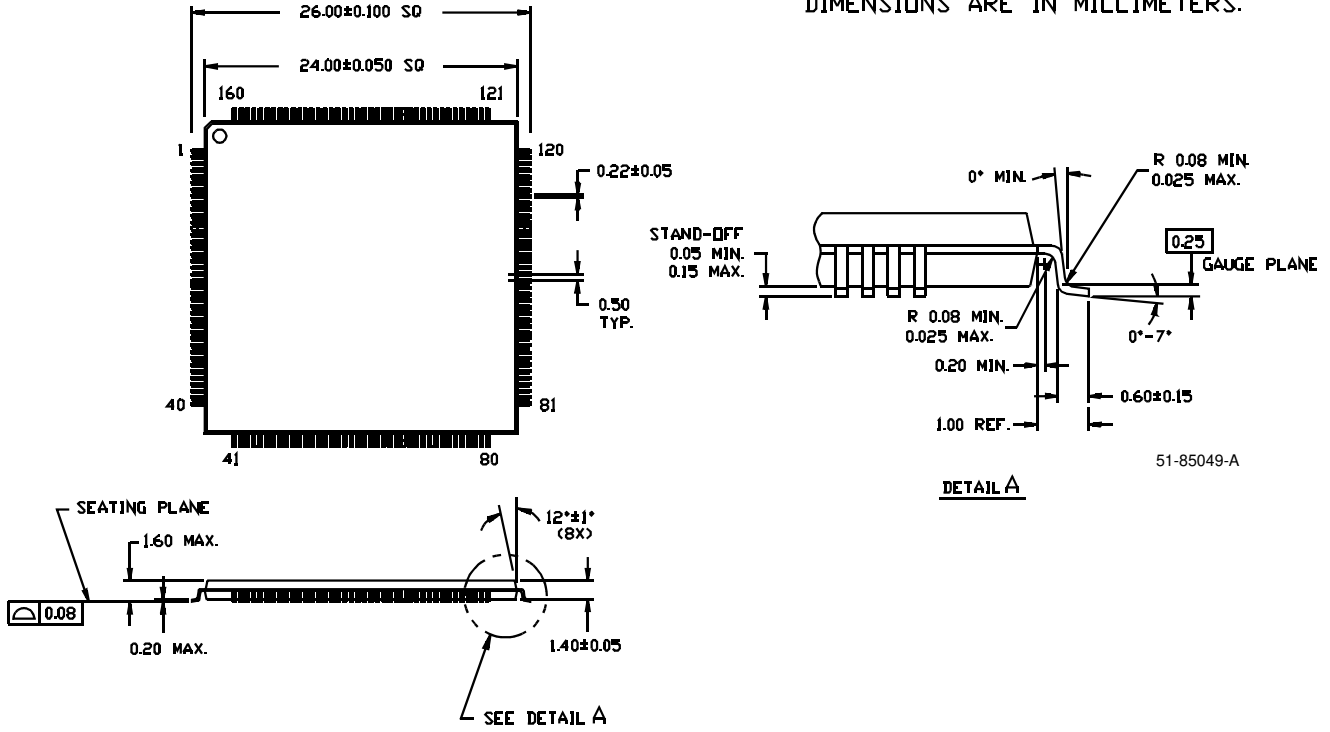

Package Diagrams (continued)

160-Pin PGA G160

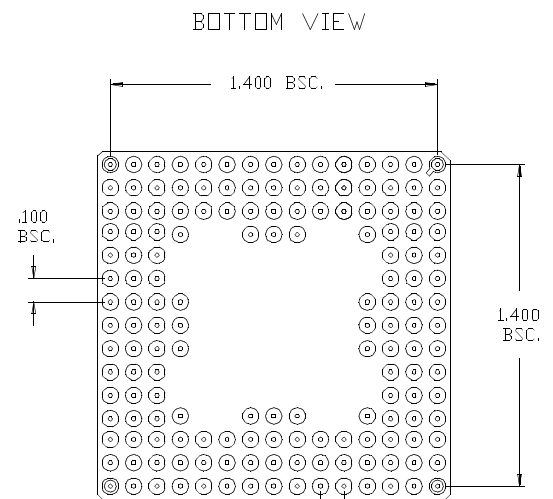
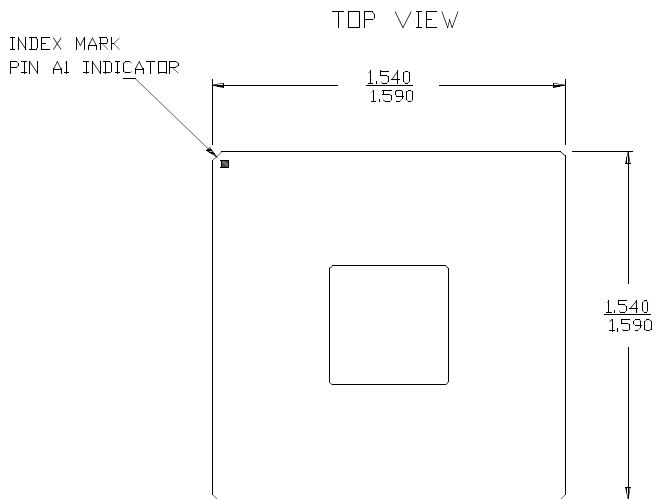

DIMENSIONS IN INCHES  
MIN.  
MAX.

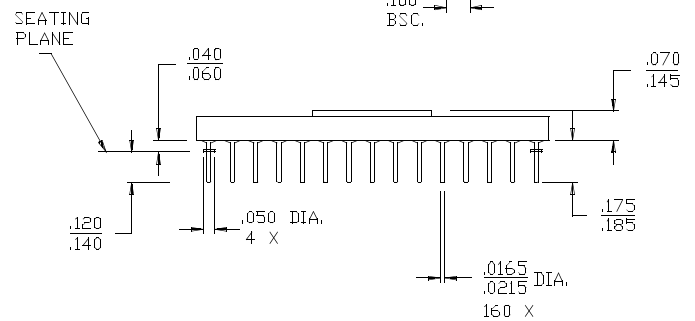

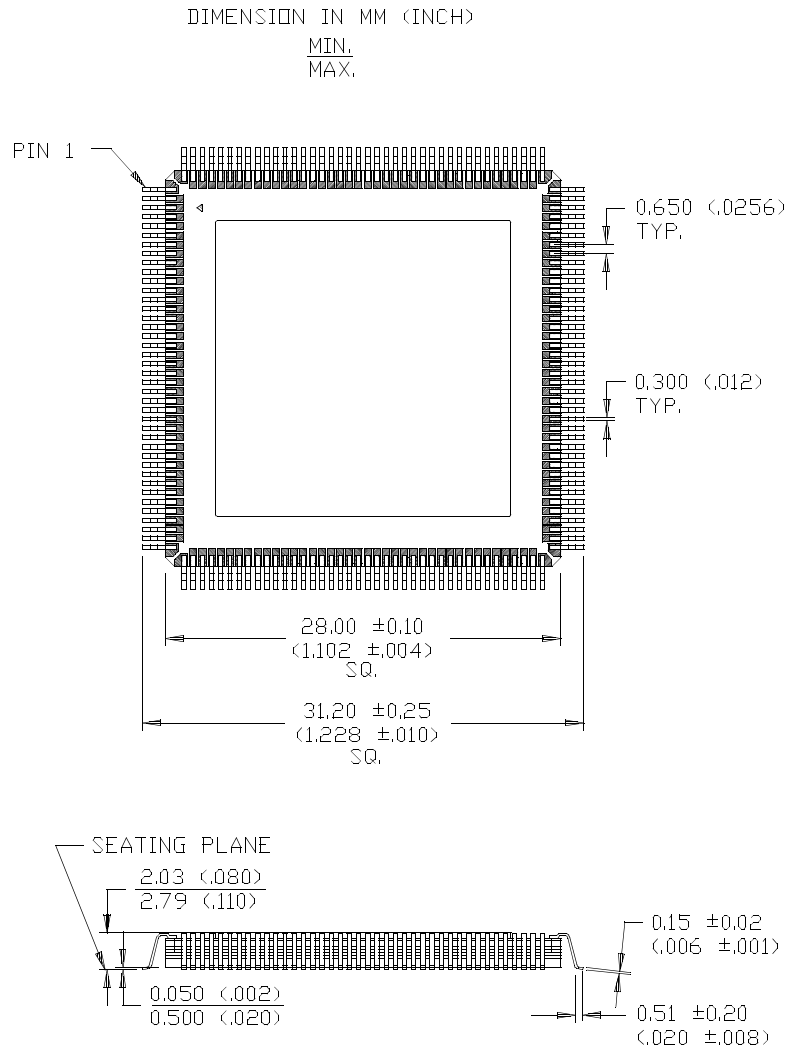

**Package Diagrams** (continued)

**160-Lead Ceramic Quad Flatpack (Cavity Up) U162**

<b>Document Title: CY7C375i UltraLogic™ 128-Macrocell Flash CPLD</b> <b>Document Number: 38-03029</b>				
<b>REV.</b>	<b>ECN NO.</b>	<b>Issue Date</b>	<b>Orig. of Change</b>	<b>Description of Change</b>
**	106374	09/15/01	SZV	Change from Spec number: 38-00494 to 38-03029