



Chipsmall Limited consists of a professional team with an average of over 10 year of expertise in the distribution of electronic components. Based in Hongkong, we have already established firm and mutual-benefit business relationships with customers from,Europe,America and south Asia,supplying obsolete and hard-to-find components to meet their specific needs.

With the principle of “Quality Parts,Customers Priority,Honest Operation,and Considerate Service”,our business mainly focus on the distribution of electronic components. Line cards we deal with include Microchip,ALPS,ROHM,Xilinx,Pulse,ON,Everlight and Freescale. Main products comprise IC,Modules,Potentiometer,IC Socket,Relay,Connector.Our parts cover such applications as commercial,industrial, and automotives areas.

We are looking forward to setting up business relationship with you and hope to provide you with the best service and solution. Let us make a better world for our industry!



## Contact us

Tel: +86-755-8981 8866 Fax: +86-755-8427 6832

Email & Skype: info@chipsmall.com Web: www.chipsmall.com

Address: A1208, Overseas Decoration Building, #122 Zhenhua RD., Futian, Shenzhen, China





**CY7C64013C**  
**CY7C64113C**

---

---

---

**Full-Speed USB (12-Mbps) Function**

# **Full-Speed USB (12-Mbps) Function**

**TABLE OF CONTENTS**

**1.0 FEATURES .....6**

**2.0 FUNCTIONAL OVERVIEW .....7**

**3.0 PIN CONFIGURATIONS .....9**

**4.0 PRODUCT SUMMARY TABLES .....10**

    4.1 Pin Assignments ..... 10

    4.2 I/O Register Summary ..... 10

    4.3 Instruction Set Summary ..... 12

**5.0 PROGRAMMING MODEL .....13**

    5.1 14-Bit Program Counter (PC) ..... 13

        5.1.1 Program Memory Organization ..... 14

    5.2 8-Bit Accumulator (A) ..... 15

    5.3 8-Bit Temporary Register (X) ..... 15

    5.4 8-Bit Program Stack Pointer (PSP) ..... 15

        5.4.1 Data Memory Organization ..... 15

    5.5 8-Bit Data Stack Pointer (DSP) ..... 16

    5.6 Address Modes ..... 16

        5.6.1 Data (Immediate) ..... 16

        5.6.2 Direct ..... 16

        5.6.3 Indexed ..... 16

**6.0 CLOCKING .....17**

**7.0 RESET .....17**

    7.1 Power-On Reset (POR) ..... 17

    7.2 Watchdog Reset (WDR) ..... 17

**8.0 SUSPEND MODE .....18**

**9.0 GENERAL-PURPOSE I/O (GPIO) PORTS .....19**

    9.1 GPIO Configuration Port ..... 20

    9.2 GPIO Interrupt Enable Ports ..... 21

**10.0 DAC PORT .....21**

    10.1 DAC Isink Registers ..... 22

    10.2 DAC Port Interrupts ..... 23

**11.0 12-BIT FREE-RUNNING TIMER .....23**

**12.0 I<sup>2</sup>C AND HAPI CONFIGURATION REGISTER .....24**

**13.0 I<sup>2</sup>C-COMPATIBLE CONTROLLER .....25**

**14.0 HARDWARE ASSISTED PARALLEL INTERFACE (HAPI) .....27**

**15.0 PROCESSOR STATUS AND CONTROL REGISTER .....28**

**16.0 INTERRUPTS .....29**

    16.1 Interrupt Vectors ..... 30

    16.2 Interrupt Latency ..... 31

    16.3 USB Bus Reset Interrupt ..... 31

    16.4 Timer Interrupt ..... 31

    16.5 USB Endpoint Interrupts ..... 31

**TABLE OF CONTENTS**

16.6 DAC Interrupt .....	31
16.7 GPIO/HAPI Interrupt .....	32
16.8 I <sup>2</sup> C Interrupt .....	32
<b>17.0 USB OVERVIEW .....</b>	<b>33</b>
17.1 USB Serial Interface Engine (SIE) .....	33
17.2 USB Enumeration .....	33
17.3 USB Upstream Port Status and Control .....	33
<b>18.0 USB SERIAL INTERFACE ENGINE OPERATION .....</b>	<b>34</b>
18.1 USB Device Address .....	34
18.2 USB Device Endpoints .....	35
18.3 USB Control Endpoint Mode Register .....	35
18.4 USB Non-Control Endpoint Mode Registers .....	36
18.5 USB Endpoint Counter Registers .....	36
18.6 Endpoint Mode/Count Registers Update and Locking Mechanism .....	37
<b>19.0 USB MODE TABLES .....</b>	<b>39</b>
<b>20.0 REGISTER SUMMARY .....</b>	<b>43</b>
<b>21.0 SAMPLE SCHEMATIC .....</b>	<b>44</b>
<b>22.0 ABSOLUTE MAXIMUM RATINGS .....</b>	<b>45</b>
<b>23.0 ELECTRICAL CHARACTERISTICS</b>	
<b>FOSC = 6 MHz; OPERATING TEMPERATURE = 0 TO 70°C, V<sub>CC</sub> = 4.0V TO 5.25V .....</b>	<b>45</b>
<b>24.0 SWITCHING CHARACTERISTICS (f<sub>OSC</sub> = 6.0 MHz) .....</b>	<b>46</b>
<b>25.0 ORDERING INFORMATION .....</b>	<b>48</b>
<b>26.0 PACKAGE DIAGRAMS .....</b>	<b>49</b>

**LIST OF FIGURES**

Figure 6-1. Clock Oscillator On-Chip Circuit ..... 17

Figure 7-1. Watchdog Reset (WDR) ..... 18

Figure 9-1. Block Diagram of a GPIO Pin ..... 19

Figure 9-2. Port 0 Data ..... 19

Figure 9-3. Port 1 Data ..... 19

Figure 9-4. Port 2 Data ..... 19

Figure 9-5. Port 3 Data ..... 20

Figure 9-6. GPIO Configuration Register ..... 20

Figure 9-7. Port 0 Interrupt Enable ..... 21

Figure 9-8. Port 1 Interrupt Enable ..... 21

Figure 9-9. Port 2 Interrupt Enable ..... 21

Figure 9-10. Port 3 Interrupt Enable ..... 21

Figure 10-1. Block Diagram of a DAC Pin ..... 22

Figure 10-2. DAC Port Data ..... 22

Figure 10-3. DAC Sink Register ..... 22

Figure 10-4. DAC Port Interrupt Enable ..... 23

Figure 10-5. DAC Port Interrupt Polarity ..... 23

Figure 11-1. Timer LSB Register ..... 23

Figure 11-2. Timer MSB Register ..... 24

Figure 11-3. Timer Block Diagram ..... 24

Figure 12-1. HAPI/I2C Configuration Register ..... 24

Figure 13-1. I<sup>2</sup>C Data Register ..... 25

Figure 13-2. I2C Status and Control Register ..... 25

Figure 15-1. Processor Status and Control Register ..... 28

Figure 16-1. Global Interrupt Enable Register ..... 29

Figure 16-2. USB Endpoint Interrupt Enable Register ..... 29

Figure 16-3. Interrupt Controller Function Diagram ..... 30

Figure 16-4. GPIO Interrupt Structure ..... 32

Figure 17-1. USB Status and Control Register ..... 34

Figure 18-1. USB Device Address Registers ..... 34

Figure 18-2. USB Device Endpoint Zero Mode Registers ..... 35

Figure 18-3. USB Non-Control Device Endpoint Mode Registers ..... 36

Figure 18-4. USB Endpoint Counter Registers ..... 36

Figure 18-5. Token/Data Packet Flow Diagram ..... 38

Figure 24-1. Clock Timing ..... 47

Figure 24-2. USB Data Signal Timing ..... 47

Figure 24-3. HAPI Read by External Interface from USB Microcontroller ..... 47

Figure 24-4. HAPI Write by External Device to USB Microcontroller ..... 48

---



---

**LIST OF TABLES**

Table 4-1. Pin Assignments .....	10
Table 4-2. I/O Register Summary .....	10
Table 4-3. Instruction Set Summary .....	12
Table 9-1. GPIO Port Output Control Truth Table and Interrupt Polarity .....	20
Table 12-1. HAPI Port Configuration .....	25
Table 12-2. I <sup>2</sup> C Port Configuration .....	25
Table 13-1. I <sup>2</sup> C Status and Control Register Bit Definitions .....	26
Table 14-1. Port 2 Pin and HAPI Configuration Bit Definitions .....	27
Table 16-1. Interrupt Vector Assignments .....	31
Table 17-1. Control Bit Definition for Upstream Port .....	34
Table 18-1. Memory Allocation for Endpoints .....	35
Table 19-1. USB Register Mode Encoding .....	39
Table 19-2. Details of Modes for Differing Traffic Conditions (see <i>Table 19-1</i> for the decode legend) .....	41

## 1.0 Features

- Full-speed USB Microcontroller
- 8-bit USB Optimized Microcontroller
  - Harvard architecture
  - 6-MHz external clock source
  - 12-MHz internal CPU clock
  - 48-MHz internal clock
- Internal memory
  - 256 bytes of RAM
  - 8 KB of PROM (CY7C64013C, CY7C64113C)
- Integrated Master/Slave I<sup>2</sup>C-compatible Controller (100 kHz) enabled through General-Purpose I/O (GPIO) pins
- Hardware Assisted Parallel Interface (HAPI) for data transfer to external devices
- I/O ports
  - Three GPIO ports (Port 0 to 2) capable of sinking 7 mA per pin (typical)
  - An additional GPIO port (Port 3) capable of sinking 12 mA per pin (typical) for high current requirements: LEDs
  - Higher current drive achievable by connecting multiple GPIO pins together to drive a common output
  - Each GPIO port can be configured as inputs with internal pull-ups or open drain outputs or traditional CMOS outputs
  - A Digital to Analog Conversion (DAC) port with programmable current sink outputs is available on the CY7C64113C devices
  - Maskable interrupts on all I/O pins
- 12-bit free-running timer with one microsecond clock ticks
- Watchdog Timer (WDT)
- Internal Power-On Reset (POR)
- USB Specification Compliance
  - Conforms to USB Specification, Version 1.1
  - Conforms to USB HID Specification, Version 1.1
  - Supports up to five user configured endpoints
    - Up to four 8-byte data endpoints
    - Up to two 32-byte data endpoints
  - Integrated USB transceivers
- Improved output drivers to reduce EMI
- Operating voltage from 4.0V to 5.5V DC
- Operating temperature from 0 to 70 degrees Celsius
  - CY7C64013C available in 28-pin SOIC and 28-pin PDIP packages
  - CY7C64113C available in 48-pin SSOP packages
- Industry-standard programmer support

## 2.0 Functional Overview

The CY7C64013C and CY7C64113C are 8-bit One Time Programmable microcontrollers that are designed for full-speed USB applications. The instruction set has been optimized specifically for USB operations, although the microcontrollers can be used for a variety of non-USB embedded applications.

### GPIO

The CY7C64013C features 19 GPIO pins to support USB and other applications. The I/O pins are grouped into three ports (P0[7:0], P1[2:0], P2[6:2], P3[2:0]) where each port can be configured as inputs with internal pull-ups, open drain outputs, or traditional CMOS outputs. There are 16 GPIO pins (Ports 0 and 1) which are rated at 7 mA typical sink current. Port 3 pins are rated at 12 mA typical sink current, a current sufficient to drive LEDs. Multiple GPIO pins can be connected together to drive a single output for more drive current capacity. Additionally, each GPIO can be used to generate a GPIO interrupt to the microcontroller. All of the GPIO interrupts share the same "GPIO" interrupt vector.

The CY7C64113C has 32 GPIO pins (P0[7:0], P1[7:0], P2[7:0], P3[7:0])

### DAC

The CY7C64113C has four programmable sink current I/O pins (DAC) pins (P4[7,2:0]). Every DAC pin includes an integrated 14-k $\Omega$  pull-up resistor. When a '1' is written to a DAC I/O pin, the output current sink is disabled and the output pin is driven HIGH by the internal pull-up resistor. When a '0' is written to a DAC I/O pin, the internal pull-up resistor is disabled and the output pin provides the programmed amount of sink current. A DAC I/O pin can be used as an input with an internal pull-up by writing a '1' to the pin.

The sink current for each DAC I/O pin can be individually programmed to one of 16 values using dedicated Isink registers. DAC bits P4[1:0] can be used as high-current outputs with a programmable sink current range of 3.2 to 16 mA (typical). DAC bits P4[7,2] have a programmable current sink range of 0.2 to 1.0 mA (typical). Multiple DAC pins can be connected together to drive a single output that requires more sink current capacity. Each I/O pin can be used to generate a DAC interrupt to the microcontroller. Also, the interrupt polarity for each DAC I/O pin is individually programmable.

### Clock

The microcontroller uses an external 6-MHz crystal and an internal oscillator to provide a reference to an internal PLL-based clock generator. This technology allows the customer application to use an inexpensive 6-MHz fundamental crystal that reduces the clock-related noise emissions (EMI). A PLL clock generator provides the 6-, 12-, and 48-MHz clock signals for distribution within the microcontroller.

### Memory

The CY7C64013C and CY7C64113C have 8 KB of PROM.

### Power on Reset, Watchdog and Free running Time

These parts include power-on reset logic, a Watchdog timer, and a 12-bit free-running timer. The power-on reset (POR) logic detects when power is applied to the device, resets the logic to a known state, and begins executing instructions at PROM address 0x0000. The Watchdog timer is used to ensure the microcontroller recovers after a period of inactivity. The firmware may become inactive for a variety of reasons, including errors in the code or a hardware failure such as waiting for an interrupt that never occurs.

### I<sup>2</sup>C and HAPI Interface

The microcontroller can communicate with external electronics through the GPIO pins. An I<sup>2</sup>C-compatible interface accommodates a 100-kHz serial link with an external device. There is also a Hardware Assisted Parallel Interface (HAPI) which can be used to transfer data to an external device.

### Timer

The free-running 12-bit timer clocked at 1 MHz provides two interrupt sources, 128- $\mu$ s and 1.024-ms. The timer can be used to measure the duration of an event under firmware control by reading the timer at the start of the event and after the event is complete. The difference between the two readings indicates the duration of the event in microseconds. The upper four bits of the timer are latched into an internal register when the firmware reads the lower eight bits. A read from the upper four bits actually reads data from the internal register, instead of the timer. This feature eliminates the need for firmware to try to compensate if the upper four bits increment immediately after the lower eight bits are read.

### Interrupts

The microcontroller supports 11 maskable interrupts in the vectored interrupt controller. Interrupt sources include the USB Bus Reset interrupt, the 128- $\mu$ s (bit 6) and 1.024-ms (bit 9) outputs from the free-running timer, five USB endpoints, the DAC port, the GPIO ports, and the I<sup>2</sup>C-compatible master mode interface. The timer bits cause an interrupt (if enabled) when the bit toggles from LOW '0' to HIGH '1.' The USB endpoints interrupt after the USB host has written data to the endpoint FIFO or after the USB controller sends a packet to the USB host. The DAC ports have an additional level of masking that allows the user to select which DAC inputs can cause a DAC interrupt. The GPIO ports also have a level of masking to select which GPIO inputs can cause a GPIO interrupt. For additional flexibility, the input transition polarity that causes an interrupt is programmable for each pin of the DAC port. Input transition polarity can be programmed for each GPIO port as part of the port configuration. The interrupt polarity can be rising edge ('0' to '1') or falling edge ('1' to '0').



**Logic Block Diagram**

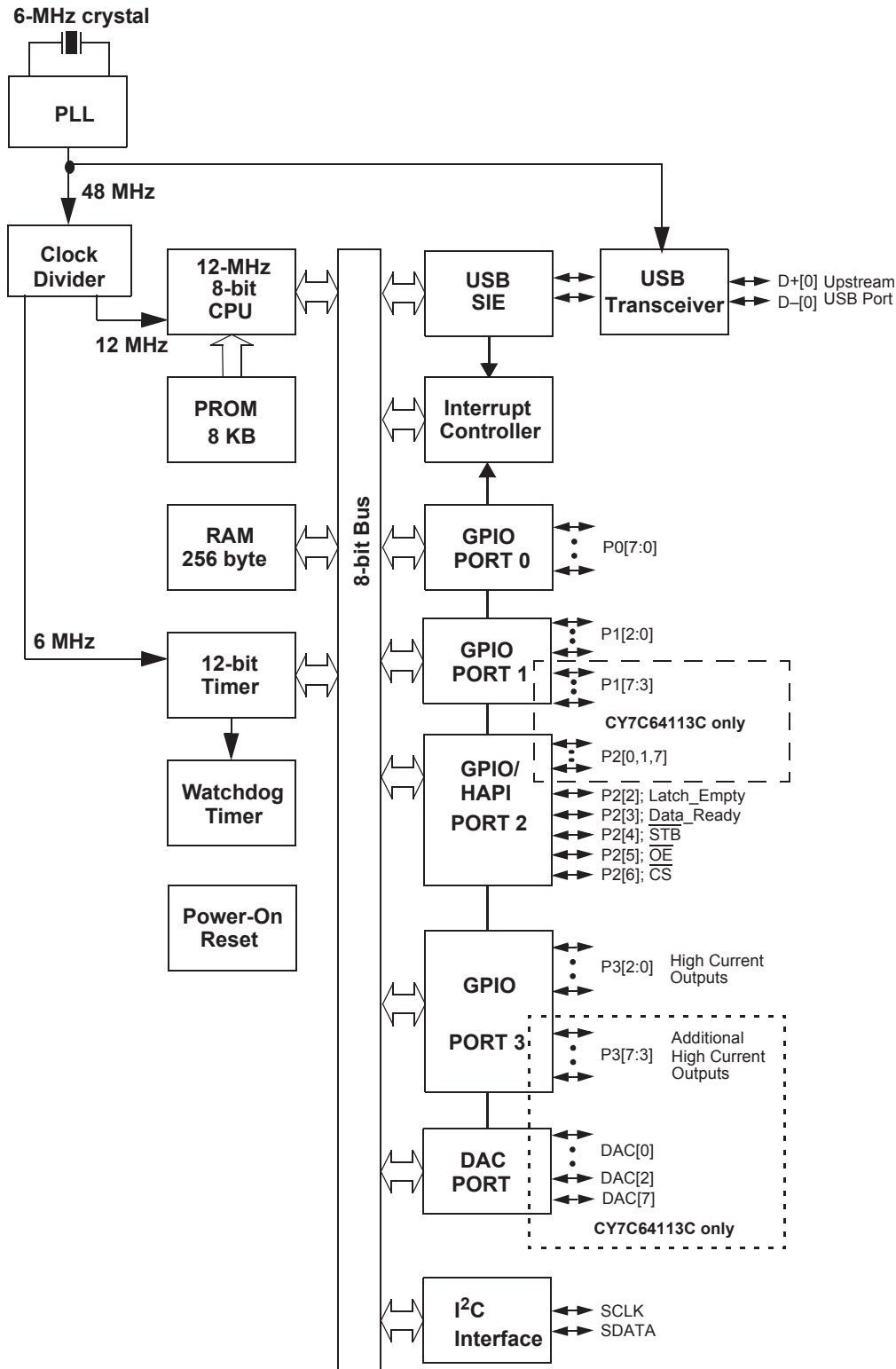

\*I²C-compatible interface enabled by firmware through P2[1:0] or P1[1:0]



## 4.0 Product Summary Tables

### 4.1 Pin Assignments

**Table 4-1. Pin Assignments**

Name	I/O	28-Pin SOIC	28-Pin PDIP	48-Pin SSOP	Description
D+[0], D-[0]	I/O	6, 7	7, 8	7, 8	Upstream port, USB differential data.
P0	I/O	P0[7:0] 10, 14, 11, 15, 12, 16, 13, 17	P0[7:0] 11, 15, 12, 16, 13, 17, 14, 18	P0[7:0] 20, 26, 21, 27, 22, 28, 23, 29	GPIO Port 0 capable of sinking 7 mA (typical).
P1	I/O	P1[2:0] 25, 27, 26	P1[2:0] 26, 4, 27	P1[7:0] 6, 43, 5, 44, 4, 45, 47, 46	GPIO Port 1 capable of sinking 7 mA (typical).
P2	I/O	P2[6:2] 19, 9, 20, 8, 21	P2[6:2] 20, 10, 21, 9, 23	P2[7:0] 18, 32, 17, 33, 15, 35, 14, 36	GPIO Port 2 capable of sinking 7 mA (typical). HAPI is also supported through P2[6:2].
P3	I/O	P3[2:0] 23, 5, 24	P3[2:0] 24, 6, 25	P3[7:0] 13, 37, 12, 39, 10, 41, 7, 42	GPIO Port 3, capable of sinking 12 mA (typical).
DAC	I/O			DAC[7,2:0] 19, 25, 24, 31	DAC Port with programmable current sink outputs. DAC[1:0] offer a programmable range of 3.2 to 16 mA typical. DAC[7,2] have a programmable sink current range of 0.2 to 1.0 mA typical.
XTAL <sub>IN</sub>	IN	2	2	2	6-MHz crystal or external clock input.
XTAL <sub>OUT</sub>	OUT	1	1	1	6-MHz crystal out.
V <sub>PP</sub>	IN	18	19	30	Programming voltage supply, tie to ground during normal operation.
V <sub>CC</sub>	IN	28	28	48	Voltage supply.
GND	IN	4, 22	5, 22	11, 16, 34, 40	Ground.
V <sub>REF</sub>	IN	3	3	3	External 3.3V supply voltage for the differential data output buffers and the D+ pull-up.
NC				38	No Connect.

### 4.2 I/O Register Summary

I/O registers are accessed via the I/O Read (IORD) and I/O Write (IOWR, IOWX) instructions. IORD reads data from the selected port into the accumulator. IOWR performs the reverse; it writes data from the accumulator to the selected port. Indexed I/O Write (IOWX) adds the contents of X to the address in the instruction to form the port address and writes data from the accumulator to the specified port. Specifying address 0 (e.g., IOWX 0h) means the I/O register is selected solely by the contents of X.

All undefined registers are reserved. It is important not to write to reserved registers as this may cause an undefined operation or increased current consumption during operation. When writing to registers with reserved bits, the reserved bits must be written with '0.'

**Table 4-2. I/O Register Summary**

Register Name	I/O Address	Read/Write	Function	Page
Port 0 Data	0x00	R/W	GPIO Port 0 Data	19
Port 1 Data	0x01	R/W	GPIO Port 1 Data	19
Port 2 Data	0x02	R/W	GPIO Port 2 Data	19
Port 3 Data	0x03	R/W	GPIO Port 3 Data	20
Port 0 Interrupt Enable	0x04	W	Interrupt Enable for Pins in Port 0	21
Port 1 Interrupt Enable	0x05	W	Interrupt Enable for Pins in Port 1	21
Port 2 Interrupt Enable	0x06	W	Interrupt Enable for Pins in Port 2	21
Port 3 Interrupt Enable	0x07	W	Interrupt Enable for Pins in Port 3	21

**Table 4-2. I/O Register Summary** (continued)

Register Name	I/O Address	Read/Write	Function	Page
GPIO Configuration	0x08	R/W	GPIO Port Configurations	20
HAPI and I <sup>2</sup> C Configuration	0x09	R/W	HAPI Width and I <sup>2</sup> C Position Configuration	24
USB Device Address A	0x10	R/W	USB Device Address A	34
EP A0 Counter Register	0x11	R/W	USB Address A, Endpoint 0 Counter	35
EP A0 Mode Register	0x12	R/W	USB Address A, Endpoint 0 Configuration	34
EP A1 Counter Register	0x13	R/W	USB Address A, Endpoint 1 Counter	35
EP A1 Mode Register	0x14	R/W	USB Address A, Endpoint 1 Configuration	35
EP A2 Counter Register	0x15	R/W	USB Address A, Endpoint 2 Counter	35
EP A2 Mode Register	0x16	R/W	USB Address A, Endpoint 2 Configuration	35
USB Status & Control	0x1F	R/W	USB Upstream Port Traffic Status and Control	34
Global Interrupt Enable	0x20	R/W	Global Interrupt Enable	29
Endpoint Interrupt Enable	0x21	R/W	USB Endpoint Interrupt Enables	29
Timer (LSB)	0x24	R	Lower 8 Bits of Free-running Timer (1 MHz)	23
Timer (MSB)	0x25	R	Upper 4 Bits of Free-running Timer	24
WDT Clear	0x26	W	Watchdog Timer Clear	18
I <sup>2</sup> C Control & Status	0x28	R/W	I <sup>2</sup> C Status and Control	25
I <sup>2</sup> C Data	0x29	R/W	I <sup>2</sup> C Data	25
DAC Data	0x30	R/W	DAC Data	22
DAC Interrupt Enable	0x31	W	Interrupt Enable for each DAC Pin	23
DAC Interrupt Polarity	0x32	W	Interrupt Polarity for each DAC Pin	23
DAC Isink	0x38-0x3F	W	Input Sink Current Control for each DAC Pin	22
Reserved	0x40		Reserved	
EP A3 Counter Register	0x41	R/W	USB Address A, Endpoint 3 Counter	35
EP A3 Mode Register	0x42	R/W	USB Address A, Endpoint 3 Configuration	34
EP A4 Counter Register	0x43	R/W	USB Address A, Endpoint 4 Counter	35
EP A4 Mode Register	0x44	R/W	USB Address A, Endpoint 4 Configuration	35
Reserved	0x48		Reserved	
Reserved	0x49		Reserved	
Reserved	0x4A		Reserved	
Reserved	0x4B		Reserved	
Reserved	0x4C		Reserved	
Reserved	0x4D		Reserved	
Reserved	0x4E		Reserved	
Reserved	0x4F		Reserved	
Reserved	0x50		Reserved	
Reserved	0x51		Reserved	
Processor Status & Control	0xFF	R/W	Microprocessor Status and Control Register	26

### 4.3 Instruction Set Summary

Refer to the *CYASM Assembler User's Guide* for more details.

**Table 4-3. Instruction Set Summary**

MNEMONIC	operand	opcode	cycles
HALT		00	7
ADD A,expr	data	01	4
ADD A,[expr]	direct	02	6
ADD A,[X+expr]	index	03	7
ADC A,expr	data	04	4
ADC A,[expr]	direct	05	6
ADC A,[X+expr]	index	06	7
SUB A,expr	data	07	4
SUB A,[expr]	direct	08	6
SUB A,[X+expr]	index	09	7
SBB A,expr	data	0A	4
SBB A,[expr]	direct	0B	6
SBB A,[X+expr]	index	0C	7
OR A,expr	data	0D	4
OR A,[expr]	direct	0E	6
OR A,[X+expr]	index	0F	7
AND A,expr	data	10	4
AND A,[expr]	direct	11	6
AND A,[X+expr]	index	12	7
XOR A,expr	data	13	4
XOR A,[expr]	direct	14	6
XOR A,[X+expr]	index	15	7
CMP A,expr	data	16	5
CMP A,[expr]	direct	17	7
CMP A,[X+expr]	index	18	8
MOV A,expr	data	19	4
MOV A,[expr]	direct	1A	5
MOV A,[X+expr]	index	1B	6
MOV X,expr	data	1C	4
MOV X,[expr]	direct	1D	5
reserved		1E	
XPAGE		1F	4
MOV A,X		40	4
MOV X,A		41	4
MOV PSP,A		60	4
CALL	addr	50 - 5F	10
JMP	addr	80-8F	5
CALL	addr	90-9F	10
JZ	addr	A0-AF	5
JNZ	addr	B0-BF	5

MNEMONIC	operand	opcode	cycles
NOP		20	4
INC A	acc	21	4
INC X	x	22	4
INC [expr]	direct	23	7
INC [X+expr]	index	24	8
DEC A	acc	25	4
DEC X	x	26	4
DEC [expr]	direct	27	7
DEC [X+expr]	index	28	8
IORD expr	address	29	5
IOWR expr	address	2A	5
POP A		2B	4
POP X		2C	4
PUSH A		2D	5
PUSH X		2E	5
SWAP A,X		2F	5
SWAP A,DSP		30	5
MOV [expr],A	direct	31	5
MOV [X+expr],A	index	32	6
OR [expr],A	direct	33	7
OR [X+expr],A	index	34	8
AND [expr],A	direct	35	7
AND [X+expr],A	index	36	8
XOR [expr],A	direct	37	7
XOR [X+expr],A	index	38	8
IOWX [X+expr]	index	39	6
CPL		3A	4
ASL		3B	4
ASR		3C	4
RLC		3D	4
RRC		3E	4
RET		3F	8
DI		70	4
EI		72	4
RETI		73	8
JC	addr	C0-CF	5
JNC	addr	D0-DF	5
JACC	addr	E0-EF	7
INDEX	addr	F0-FF	14

## **5.0 Programming Model**

### **5.1 14-Bit Program Counter (PC)**

The 14-bit program counter (PC) allows access to up to 8 KB of PROM available with the CY7C64x13C architecture. The top 32 bytes of the ROM in the 8 Kb part are reserved for testing purposes. The program counter is cleared during reset, such that the first instruction executed after a reset is at address 0x0000h. Typically, this is a jump instruction to a reset handler that initializes the application (see Interrupt Vectors on page 30).

The lower eight bits of the program counter are incremented as instructions are loaded and executed. The upper six bits of the program counter are incremented by executing an XPAGE instruction. As a result, the last instruction executed within a 256-byte “page” of sequential code should be an XPAGE instruction. The assembler directive “XPAGEON” causes the assembler to insert XPAGE instructions automatically. Because instructions can be either one or two bytes long, the assembler may occasionally need to insert a NOP followed by an XPAGE to execute correctly.

The address of the next instruction to be executed, the carry flag, and the zero flag are saved as two bytes on the program stack during an interrupt acknowledge or a CALL instruction. The program counter, carry flag, and zero flag are restored from the program stack during a RETI instruction. Only the program counter is restored during a RET instruction.

The program counter cannot be accessed directly by the firmware. The program stack can be examined by reading SRAM from location 0x00 and up.

5.1.1 Program Memory Organization

after reset	Address	
14-bit PC →	0x0000	Program execution begins here after a reset
	0x0002	USB Bus Reset interrupt vector
	0x0004	128- $\mu$ s timer interrupt vector
	0x0006	1.024-ms timer interrupt vector
	0x0008	USB address A endpoint 0 interrupt vector
	0x000A	USB address A endpoint 1 interrupt vector
	0x000C	USB address A endpoint 2 interrupt vector
	0x000E	USB address A endpoint 3 interrupt vector
	0x0010	USB address A endpoint 4 interrupt vector
	0x0012	Reserved
	0x0014	DAC interrupt vector
	0x0016	GPIO interrupt vector
	0x0018	I <sup>2</sup> C interrupt vector
	0x001A	<b>Program Memory begins here</b>
	0x1FDF	<b>8 KB (-32) PROM ends here (CY7C64013C, CY7C64113C)</b>

### 5.2 8-Bit Accumulator (A)

The accumulator is the general-purpose register for the microcontroller.

### 5.3 8-Bit Temporary Register (X)

The “X” register is available to the firmware for temporary storage of intermediate results. The microcontroller can perform indexed operations based on the value in X. Refer to Section 5.6.3 for additional information.

### 5.4 8-Bit Program Stack Pointer (PSP)

During a reset, the program stack pointer (PSP) is set to 0x00 and “grows” upward from this address. The PSP may be set by firmware, using the MOV PSP,A instruction. The PSP supports interrupt service under hardware control and CALL, RET, and RETI instructions under firmware control. The PSP is not readable by the firmware.

During an interrupt acknowledge, interrupts are disabled and the 14-bit program counter, carry flag, and zero flag are written as two bytes of data memory. The first byte is stored in the memory addressed by the PSP, then the PSP is incremented. The second byte is stored in memory addressed by the PSP, and the PSP is incremented again. The overall effect is to store the program counter and flags on the program “stack” and increment the PSP by two.

The Return from Interrupt (RETI) instruction decrements the PSP, then restores the second byte from memory addressed by the PSP. The PSP is decremented again and the first byte is restored from memory addressed by the PSP. After the program counter and flags have been restored from stack, the interrupts are enabled. The overall effect is to restore the program counter and flags from the program stack, decrement the PSP by two, and reenables interrupts.

The Call Subroutine (CALL) instruction stores the program counter and flags on the program stack and increments the PSP by two.

The Return from Subroutine (RET) instruction restores the program counter but not the flags from the program stack and decrements the PSP by two.

#### 5.4.1 Data Memory Organization

The CY7C64x13C microcontrollers provide 256 bytes of data RAM. Normally, the SRAM is partitioned into four areas: program stack, user variables, data stack, and USB endpoint FIFOs. The following is one example of where the program stack, data stack, and user variables areas could be located.

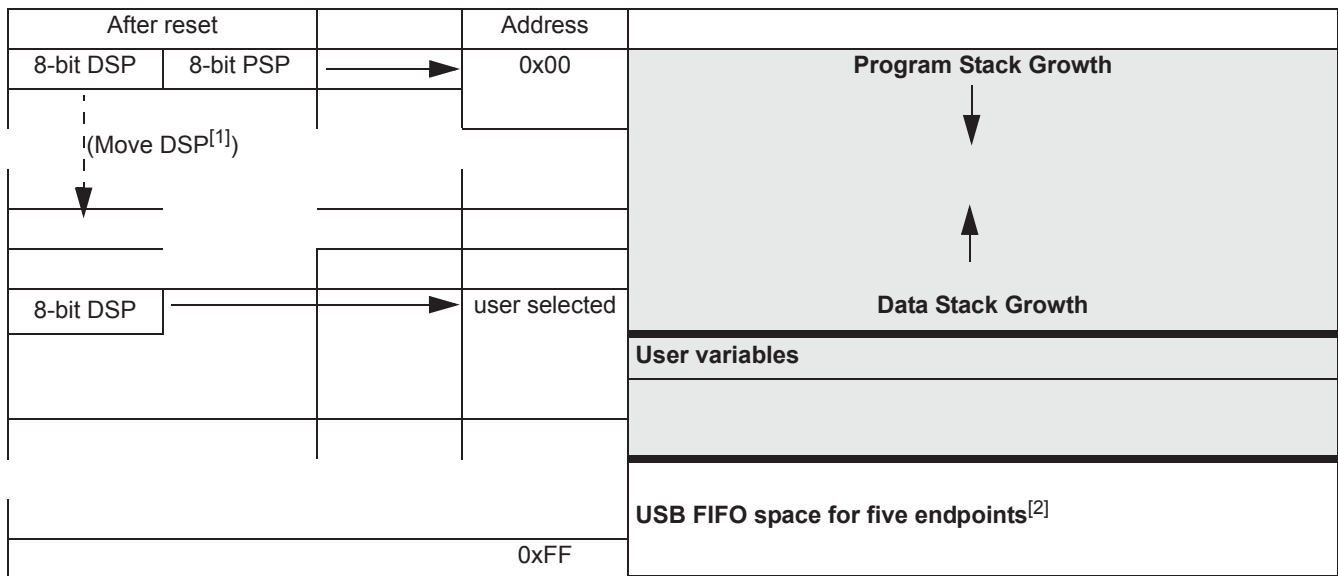

**Notes:**

1. Refer to Section 5.5 for a description of DSP.
2. Endpoint sizes are fixed by the Endpoint Size Bit (I/O register 0x1F, Bit 7), see Table 18-1.



## 5.5 8-Bit Data Stack Pointer (DSP)

The data stack pointer (DSP) supports PUSH and POP instructions that use the data stack for temporary storage. A PUSH instruction pre-decrements the DSP, then writes data to the memory location addressed by the DSP. A POP instruction reads data from the memory location addressed by the DSP, then post-increments the DSP.

During a reset, the DSP is reset to 0x00. A PUSH instruction when DSP equals 0x00 writes data at the top of the data RAM (address 0xFF). This writes data to the memory area reserved for USB endpoint FIFOs. Therefore, the DSP should be indexed at an appropriate memory location that does not compromise the Program Stack, user-defined memory (variables), or the USB endpoint FIFOs.

For USB applications, the firmware should set the DSP to an appropriate location to avoid a memory conflict with RAM dedicated to USB FIFOs. The memory requirements for the USB endpoints are described in Section 18.2. Example assembly instructions to do this with two device addresses (FIFOs begin at 0xD8) are shown below:

```
MOV A,20h ; Move 20 hex into Accumulator (must be D8h or less)
SWAP A,DSP ; swap accumulator value into DSP register
```

## 5.6 Address Modes

The CY7C64013C and CY7C64113C microcontrollers support three addressing modes for instructions that require data operands: data, direct, and indexed.

### 5.6.1 Data (Immediate)

“Data” address mode refers to a data operand that is actually a constant encoded in the instruction. As an example, consider the instruction that loads A with the constant 0xD8:

- MOV A,0D8h

This instruction requires two bytes of code where the first byte identifies the “MOV A” instruction with a data operand as the second byte. The second byte of the instruction is the constant “0xD8.” A constant may be referred to by name if a prior “EQU” statement assigns the constant value to the name. For example, the following code is equivalent to the example shown above:

- DSPINIT: EQU 0D8h
- MOV A,DSPINIT

### 5.6.2 Direct

“Direct” address mode is used when the data operand is a variable stored in SRAM. In that case, the one byte address of the variable is encoded in the instruction. As an example, consider an instruction that loads A with the contents of memory address location 0x10:

- MOV A,[10h]

Normally, variable names are assigned to variable addresses using “EQU” statements to improve the readability of the assembler source code. As an example, the following code is equivalent to the example shown above:

- buttons: EQU 10h
- MOV A,[buttons]

### 5.6.3 Indexed

“Indexed” address mode allows the firmware to manipulate arrays of data stored in SRAM. The address of the data operand is the sum of a constant encoded in the instruction and the contents of the “X” register. Normally, the constant is the “base” address of an array of data and the X register contains an index that indicates which element of the array is actually addressed:

- array: EQU 10h
- MOV X,3
- MOV A,[X+array]

This would have the effect of loading A with the fourth element of the SRAM “array” that begins at address 0x10. The fourth element would be at address 0x13.

## 6.0 Clocking

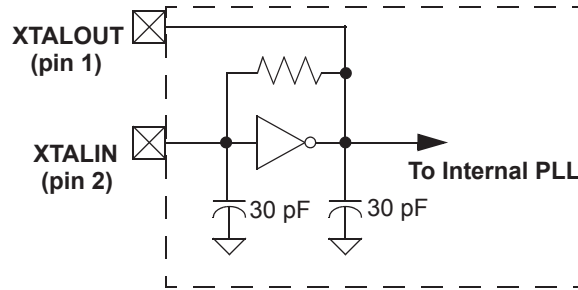

**Figure 6-1. Clock Oscillator On-Chip Circuit**

The XTALIN and XTALOUT are the clock pins to the microcontroller. The user can connect an external oscillator or a crystal to these pins. When using an external crystal, keep PCB traces between the chip leads and crystal as short as possible (less than 2 cm). A 6-MHz fundamental frequency parallel resonant crystal can be connected to these pins to provide a reference frequency for the internal PLL. The two internal 30-pF load caps appear in series to the external crystal and would be equivalent to a 15-pF load. Therefore, the crystal must have a required load capacitance of about 15–18 pF. A ceramic resonator does not allow the microcontroller to meet the timing specifications of full speed USB and therefore a ceramic resonator is not recommended with these parts.

An external 6-MHz clock can be applied to the XTALIN pin if the XTALOUT pin is left open. Grounding the XTALOUT pin when driving XTALIN with an oscillator does not work because the internal clock is effectively shorted to ground.

## 7.0 Reset

The CY7C64x13C supports two resets: Power-On Reset (POR) and a Watchdog Reset (WDR). Each of these resets causes:

- all registers to be restored to their default states,
- the USB Device Address to be set to 0,
- all interrupts to be disabled,
- the PSP and Data Stack Pointer (DSP) to be set to memory address 0x00.

The occurrence of a reset is recorded in the Processor Status and Control Register, as described in Section 15.0. Bits 4 and 6 are used to record the occurrence of POR and WDR, respectively. Firmware can interrogate these bits to determine the cause of a reset.

Program execution starts at ROM address 0x0000 after a reset. Although this looks like interrupt vector 0, there is an important difference. Reset processing does NOT push the program counter, carry flag, and zero flag onto program stack. The firmware reset handler should configure the hardware before the “main” loop of code. Attempting to execute a RET or RETI in the firmware reset handler causes unpredictable execution results.

### 7.1 Power-On Reset (POR)

When  $V_{CC}$  is first applied to the chip, the Power-On Reset (POR) signal is asserted and the CY7C64x13C enters a “semi-suspend” state. During the semi-suspend state, which is different from the suspend state defined in the USB specification, the oscillator and all other blocks of the part are functional, except for the CPU. This semi-suspend time ensures that both a valid  $V_{CC}$  level is reached and that the internal PLL has time to stabilize before full operation begins. When the  $V_{CC}$  has risen above approximately 2.5V, and the oscillator is stable, the POR is deasserted and the on-chip timer starts counting. The first 1 ms of suspend time is not interruptible, and the semi-suspend state continues for an additional 95 ms unless the count is bypassed by a USB Bus Reset on the upstream port. The 95 ms provides time for  $V_{CC}$  to stabilize at a valid operating voltage before the chip executes code.

If a USB Bus Reset occurs on the upstream port during the 95-ms semi-suspend time, the semi-suspend state is aborted and program execution begins immediately from address 0x0000. In this case, the Bus Reset interrupt is pending but not serviced until firmware sets the USB Bus Reset Interrupt Enable bit (bit 0 of register 0x20) and enables interrupts with the EI command.

The POR signal is asserted whenever  $V_{CC}$  drops below approximately 2.5V, and remains asserted until  $V_{CC}$  rises above this level again. Behavior is the same as described above.

### 7.2 Watchdog Reset (WDR)

The Watchdog Timer Reset (WDR) occurs when the internal Watchdog timer rolls over. Writing any value to the write-only Watchdog Restart Register at address 0x26 clears the timer. The timer rolls over and WDR occurs if it is not cleared within  $t_{WATCH}$  (8 ms minimum) of the last clear. Bit 6 of the Processor Status and Control Register is set to record this event (the register contents are set to 010X0001 by the WDR). A Watchdog Timer Reset lasts for 2 ms, after which the microcontroller begins execution at ROM address 0x0000.

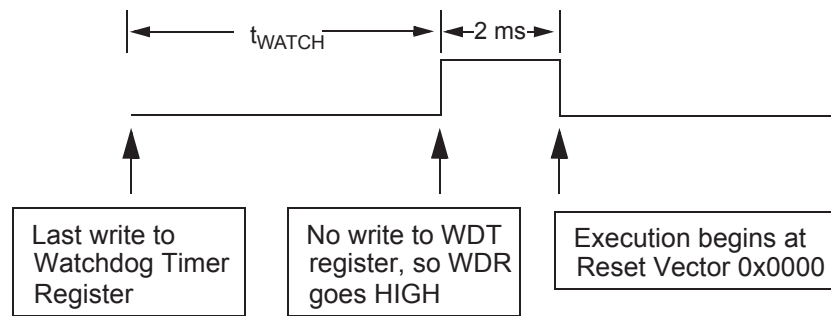

Figure 7-1. Watchdog Reset (WDR)

The USB transmitter is disabled by a Watchdog Reset because the USB Device Address Register is cleared (see Section 18.1). Otherwise, the USB Controller would respond to all address 0 transactions.

It is possible for the WDR bit of the Processor Status and Control Register (0xFF) to be set following a POR event. The WDR bit should be ignored. If the firmware interrogates the Processor Status and Control Register for a Set condition on the WDR bit and if the POR (bit 3 of register 0xFF) bit is set.

## 8.0 Suspend Mode

The CY7C64x13C can be placed into a low-power state by setting the Suspend bit of the Processor Status and Control register. All logic blocks in the device are turned off except the GPIO interrupt logic and the USB receiver. The clock oscillator and PLL, as well as the free-running and Watchdog timers, are shut down. Only the occurrence of an enabled GPIO interrupt or non-idle bus activity at a USB upstream or downstream port wakes the part out of suspend. The Run bit in the Processor Status and Control Register must be set to resume a part out of suspend.

The clock oscillator restarts immediately after exiting suspend mode. The microcontroller returns to a fully functional state 1 ms after the oscillator is stable. The microcontroller executes the instruction following the I/O write that placed the device into suspend mode before servicing any interrupt requests.

The GPIO interrupt allows the controller to wake-up periodically and poll system components while maintaining a very low average power consumption. To achieve the lowest possible current during suspend mode, all I/O should be held at  $V_{CC}$  or Gnd. This also applies to internal port pins that may not be bonded in a particular package.

Typical code for entering suspend is shown below:

```

...           ; All GPIO set to low-power state (no floating pins)
...           ; Enable GPIO interrupts if desired for wake-up
mov a, 09h    ; Set suspend and run bits
iowr FFh     ; Write to Status and Control Register - Enter suspend, wait for USB activity (or GPIO Interrupt)
nop          ; This executes before any ISR
...           ; Remaining code for exiting suspend routine

```



Port 3 Data								ADDRESS 0x03
Bit #	7	6	5	4	3	2	1	0
Bit Name	P3.7	P3.6	P3.5	P3.4	P3.3	P3.2	P3.1	P3.0
Read/Write	R/W	R/W	R/W	R/W	R/W	R/W	R/W	R/W
Reset	1	1	1	1	1	1	1	1

**Figure 9-5. Port 3 Data**

Special care should be taken with any unused GPIO data bits. An unused GPIO data bit, either a pin on the chip or a port bit that is not bonded on a particular package, must not be left floating when the device enters the suspend state. If a GPIO data bit is left floating, the leakage current caused by the floating bit may violate the suspend current limitation specified by the USB Specifications. If a '1' is written to the unused data bit and the port is configured with open drain outputs, the unused data bit remains in an indeterminate state. Therefore, if an unused port bit is programmed in open-drain mode, it must be written with a '0.' Notice that the CY7C64013C part always requires that the data bits P1[7:3], P2[7,1,0], and P3[7:3] be written with a '0.'

In normal non-HAPI mode, reads from a GPIO port always return the present state of the voltage at the pin, independent of the settings in the Port Data Registers. If HAPI mode is activated for a port, reads of that port return latched data as controlled by the HAPI signals (see Section 14.0). During reset, all of the GPIO pins are set to a high-impedance input state ('1' in open drain mode). Writing a '0' to a GPIO pin drives the pin LOW. In this state, a '0' is always read on that GPIO pin unless an external source overdrives the internal pull-down device.

### 9.1 GPIO Configuration Port

Every GPIO port can be programmed as inputs with internal pull-ups, outputs LOW or HIGH, or Hi-Z (floating, the pin is not driven internally). In addition, the interrupt polarity for each port can be programmed. The Port Configuration bits (*Figure 9-6*) and the Interrupt Enable bit (*Figure 9-7* through *Figure 9-10*) determine the interrupt polarity of the port pins.

GPIO Configuration								ADDRESS 0x08
Bit #	7	6	5	4	3	2	1	0
Bit Name	Port 3 Config Bit 1	Port 3 Config Bit 0	Port 2 Config Bit 1	Port 2 Config Bit 0	Port 1 Config Bit 1	Port 1 Config Bit 0	Port 0 Config Bit 1	Port 0 Config Bit 0
Read/Write	R/W	R/W	R/W	R/W	R/W	R/W	R/W	R/W
Reset	0	0	0	0	0	0	0	0

**Figure 9-6. GPIO Configuration Register**

As shown in *Table 9-1* below, a positive polarity on an input pin represents a rising edge interrupt (LOW to HIGH), and a negative polarity on an input pin represents a falling edge interrupt (HIGH to LOW).

The GPIO interrupt is generated when all of the following conditions are met: the Interrupt Enable bit of the associated Port Interrupt Enable Register is enabled, the GPIO Interrupt Enable bit of the Global Interrupt Enable Register (*Figure 16-1*) is enabled, the Interrupt Enable Sense (bit 2, *Figure 15-1*) is set, and the GPIO pin of the port sees an event matching the interrupt polarity.

The driving state of each GPIO pin is determined by the value written to the pin's Data Register (*Figure 9-2* through *Figure 9-5*) and by its associated Port Configuration bits as shown in the GPIO Configuration Register (*Figure 9-6*). These ports are configured on a per-port basis, so all pins in a given port are configured together. The possible port configurations are detailed in *Table 9-1*. As shown in this table below, when a GPIO port is configured with CMOS outputs, interrupts from that port are disabled.

During reset, all of the bits in the GPIO Configuration Register are written with '0' to select Hi-Z mode for all GPIO ports as the default configuration.

**Table 9-1. GPIO Port Output Control Truth Table and Interrupt Polarity**

Port Config Bit 1	Port Config Bit 0	Data Register	Output Drive Strength	Interrupt Enable Bit	Interrupt Polarity
1	1	0	Output LOW	0	Disabled
		1	Resistive	1	– (Falling Edge)
1	0	0	Output LOW	0	Disabled
		1	Output HIGH	1	Disabled
0	1	0	Output LOW	0	Disabled
		1	Hi-Z	1	– (Falling Edge)
0	0	0	Output LOW	0	Disabled
		1	Hi-Z	1	+ (Rising Edge)

Q1, Q2, and Q3 discussed below are the transistors referenced in *Figure 9-1*. The available GPIO drive strength are:

- **Output LOW Mode:** The pin's Data Register is set to '0'  
Writing '0' to the pin's Data Register puts the pin in output LOW mode, regardless of the contents of the Port Configuration Bits[1:0]. In this mode, Q1 and Q2 are OFF. Q3 is ON. The GPIO pin is driven LOW through Q3.
- **Output HIGH Mode:** The pin's Data Register is set to 1 and the Port Configuration Bits[1:0] is set to '10'  
In this mode, Q1 and Q3 are OFF. Q2 is ON. The GPIO is pulled up through Q2. The GPIO pin is capable of sourcing... of current.
- **Resistive Mode:** The pin's Data Register is set to 1 and the Port Configuration Bits[1:0] is set to '11'  
Q2 and Q3 are OFF. Q1 is ON. The GPIO pin is pulled up with an internal 14kΩ resistor. In resistive mode, the pin may serve as an input. Reading the pin's Data Register returns a logic HIGH if the pin is not driven LOW by an external source.
- **Hi-Z Mode:** The pin's Data Register is set to 1 and Port Configuration Bits[1:0] is set either '00' or '01'  
Q1, Q2, and Q3 are all OFF. The GPIO pin is not driven internally. In this mode, the pin may serve as an input. Reading the Port Data Register returns the actual logic value on the port pins.

## 9.2 GPIO Interrupt Enable Ports

Each GPIO pin can be individually enabled or disabled as an interrupt source. The Port 0–3 Interrupt Enable registers provide this feature with an interrupt enable bit for each GPIO pin. When HAPI mode (discussed in Section 14.0) is enabled the GPIO interrupts are blocked, including ports not used by HAPI, so GPIO pins cannot be used as interrupt sources.

During a reset, GPIO interrupts are disabled by clearing all of the GPIO interrupt enable ports. Writing a '1' to a GPIO Interrupt Enable bit enables GPIO interrupts from the corresponding input pin. All GPIO pins share a common interrupt, as discussed in Section 16.7

Port 0 Interrupt Enable								ADDRESS 0x04
Bit #	7	6	5	4	3	2	1	0
Bit Name	P0.7 Intr Enable	P0.6 Intr Enable	P0.5 Intr Enable	P0.4 Intr Enable	P0.3 Intr Enable	P0.2 Intr Enable	P0.1 Intr Enable	P0.0 Intr Enable
Read/Write	W	W	W	W	W	W	W	W
Reset	0	0	0	0	0	0	0	0

Figure 9-7. Port 0 Interrupt Enable

Bit #	7	6	5	4	3	2	1	0
Bit Name	P1.7 Intr Enable	P1.6 Intr Enable	P1.5 Intr Enable	P1.4 Intr Enable	P1.3 Intr Enable	P1.2 Intr Enable	P1.1 Intr Enable	P1.0 Intr Enable
Read/Write	W	W	W	W	W	W	W	W
Reset	0	0	0	0	0	0	0	0

Figure 9-8. Port 1 Interrupt Enable

Port 2 Interrupt Enable								ADDRESS 0x06
Bit #	7	6	5	4	3	2	1	0
Bit Name	P2.7 Intr Enable	P2.6 Intr Enable	P2.5 Intr Enable	P2.4 Intr Enable	P2.3 Intr Enable	P2.2 Intr Enable	P2.1 Intr Enable	P2.0 Intr Enable
Read/Write	W	W	W	W	W	W	W	W
Reset	0	0	0	0	0	0	0	0

Figure 9-9. Port 2 Interrupt Enable

Port 3 Interrupt Enable								ADDRESS 0x07
Bit #	7	6	5	4	3	2	1	0
Bit Name	Reserved (Set to 0)	P3.6 Intr Enable	P3.5 Intr Enable	P3.4 Intr Enable	P3.3 Intr Enable	P3.2 Intr Enable	P3.1 Intr Enable	P3.0 Intr Enable
Read/Write	W	W	W	W	W	W	W	W
Reset	0	0	0	0	0	0	0	0

Figure 9-10. Port 3 Interrupt Enable

## 10.0 DAC Port

The CY7C64113C features a programmable current sink 4 bit port which is also known as a DAC port. Each of these port I/O pins have a programmable current sink. Writing a '1' to a DAC I/O pin disables the output current sink (Isink DAC) and drives the I/O pin HIGH through an integrated 14-kΩ resistor. When a '0' is written to a DAC I/O pin, the Isink DAC is enabled and the pull-up resistor is disabled. This causes the Isink DAC to sink current to drive the output LOW. *Figure 10-1* shows a block diagram of the DAC port pin.

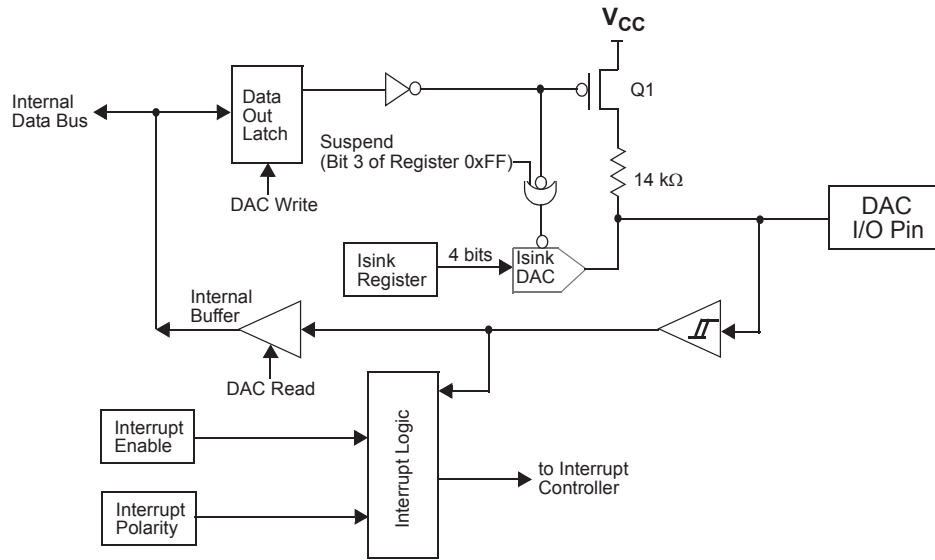

**Figure 10-1. Block Diagram of a DAC Pin**

The amount of sink current for the DAC I/O pin is programmable over 16 values based on the contents of the DAC Isink Register for that output pin. DAC[1:0] are high-current outputs that are programmable from 3.2 mA to 16 mA (typical). DAC[7:2] are low-current outputs, programmable from 0.2 mA to 1.0 mA (typical).

When the suspend bit in Processor Status and Control Register (see *Figure 15-1*) is set, the Isink DAC block of the DAC circuitry is disabled. Special care should be taken when the CY7C64x13C device is placed in the suspend mode. The DAC Port Data Register (see *Figure 10-2*) should normally be loaded with all '1's (0xFF) before setting the suspend bit. If any of the DAC bits are set to '0' when the device is suspended, that DAC input will float. The floating pin could result in excessive current consumption by the device, unless an external load places the pin in a deterministic state.

DAC Port Data								ADDRESS 0x30
Bit #	7	6	5	4	3	2	1	0
Bit Name	DAC[7]	Reserved	Reserved	Reserved	Reserved	DAC[2]	DAC[1]	DAC[0]
Read/Write	R/W	R/W	R/W	R/W	R/W	R/W	R/W	R/W
Reset	1	1	1	1	1	1	1	1

**Figure 10-2. DAC Port Data**

**Bit [1..0]: High Current Output 3.2 mA to 16 mA typical**

1 = I/O pin is an output pulled HIGH through the 14-kΩ resistor. 0 = I/O pin is an input with an internal 14-kΩ pull-up resistor

**Bit [3..2]: Low Current Output 0.2 mA to 1 mA typical**

1 = I/O pin is an output pulled HIGH through the 14-kΩ resistor. 0 = I/O pin is an input with an internal 14-kΩ pull-up resistor

**10.1 DAC Isink Registers**

Each DAC I/O pin has an associated DAC Isink register to program the output sink current when the output is driven LOW. The first Isink register (0x38) controls the current for DAC[0], the second (0x39) for DAC[1], and so on until the Isink register at 0x3F controls the current to DAC[7].

DAC Sink Register								ADDRESS 0x38 -0x3F
Bit #	7	6	5	4	3	2	1	0
Bit Name	Reserved	Reserved	Reserved	Reserved	Isink[3]	Isink[2]	Isink[1]	Isink[0]
Read/Write					W	W	W	W
Reset	-	-	-	-	0	0	0	0

**Figure 10-3. DAC Sink Register**

**Bit [4..0]: Isink [x] (x= 0..4)**

Writing all '0's to the Isink register causes 1/5 of the max current to flow through the DAC I/O pin. Writing all '1's to the Isink register provides the maximum current flow through the pin. The other 14 states of the DAC sink current are evenly spaced between these two values.

**Bit [7..5]: Reserved**

**10.2 DAC Port Interrupts**

A DAC port interrupt can be enabled/disabled for each pin individually. The DAC Port Interrupt Enable register provides this feature with an interrupt enable bit for each DAC I/O pin. All of the DAC Port Interrupt Enable register bits are cleared to '0' during a reset. All DAC pins share a common interrupt, as explained in Section 16.6.

DAC Port Interrupt								ADDRESS 0x31
Bit #	7	6	5	4	3	2	1	0
Bit Name	Enable Bit 7	Reserved	Reserved	Reserved	Reserved	Enable Bit 2	Enable Bit 1	Enable Bit 0
Read/Write	W	W	W	W	W	W	W	W
Reset	0	0	0	0	0	0	0	0

**Figure 10-4. DAC Port Interrupt Enable**

**Bit [7..0]: Enable bit x (x= 0..2, 7)**

1= Enables interrupts from the corresponding bit position; 0= Disables interrupts from the corresponding bit position

As an additional benefit, the interrupt polarity for each DAC pin is programmable with the DAC Port Interrupt Polarity register. Writing a '0' to a bit selects negative polarity (falling edge) that causes an interrupt (if enabled) if a falling edge transition occurs on the corresponding input pin. Writing a '1' to a bit in this register selects positive polarity (rising edge) that causes an interrupt (if enabled) if a rising edge transition occurs on the corresponding input pin. All of the DAC Port Interrupt Polarity register bits are cleared during a reset.

DAC Port Interrupt Polarity								ADDRESS 0x32
Bit #	7	6	5	4	3	2	1	0
Bit Name	Enable Bit 7	Reserved	Reserved	Reserved	Reserved	Enable Bit 2	Enable Bit 1	Enable Bit 0
Read/Write	W	W	W	W	W	W	W	W
Reset	0	0	0	0	0	0	0	0

**Figure 10-5. DAC Port Interrupt Polarity**

**Bit [7..0]: Enable bit x (x= 0..2, 7)**

1= Selects positive polarity (rising edge) that causes an interrupt (if enabled);  
0= Selects negative polarity (falling edge) that causes an interrupt (if enabled)

**11.0 12-Bit Free-Running Timer**

The 12-bit timer provides two interrupts (128-μs and 1.024-ms) and allows the firmware to directly time events that are up to 4 ms in duration. The lower 8 bits of the timer can be read directly by the firmware. Reading the lower 8 bits latches the upper 4 bits into a temporary register. When the firmware reads the upper 4 bits of the timer, it is accessing the count stored in the temporary register. The effect of this logic is to ensure a stable 12-bit timer value can be read, even when the two reads are separated in time.

Timer LSB								ADDRESS 0x24
Bit #	7	6	5	4	3	2	1	0
Bit Name	Timer Bit 7	Timer Bit 6	Timer Bit 5	Timer Bit 4	Timer Bit 3	Timer Bit 2	Timer Bit 1	Timer Bit 0
Read/Write	R	R	R	R	R	R	R	R
Reset	0	0	0	0	0	0	0	0

**Figure 11-1. Timer LSB Register**

**Bit [7:0]: Timer lower 8 bits**



Timer MSB								ADDRESS 0x25
Bit #	7	6	5	4	3	2	1	0
Bit Name	Reserved	Reserved	Reserved	Reserved	Timer Bit 11	Timer Bit 10	Timer Bit 9	Timer Bit 8
Read/Write	-	-	-	-	R	R	R	R
Reset	0	0	0	0	0	0	0	0

Figure 11-2. Timer MSB Register

Bit [3:0]: Timer higher nibble

Bit [7:4]: Reserved

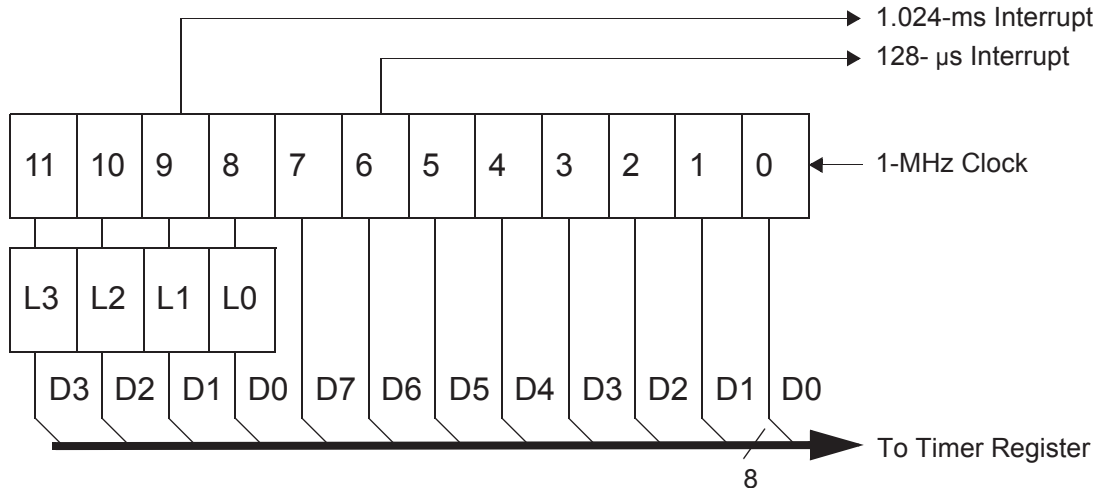

Figure 11-3. Timer Block Diagram

## 12.0 I<sup>2</sup>C and HAPI Configuration Register

Internal hardware supports communication with external devices through two interfaces: a two-wire I<sup>2</sup>C-compatible interface, and a HAPI for 1, 2, or 3 byte transfers. The I<sup>2</sup>C-compatible interface and HAPI functions, discussed in detail in Sections 13.0 and 14.0, share a common configuration register (see Figure 12-1). All bits of this register are cleared on reset.

I <sup>2</sup> C Configuration								ADDRESS 0x09
Bit #	7	6	5	4	3	2	1	0
Bit Name	I <sup>2</sup> C Position	Reserved	EMPTY Polarity	DRDY Polarity	Latch Empty	Data Ready	HAPI Port Width Bit 1	HAPI Port Width Bit 0
Read/Write	R/W	-	R/W	R/W	R	R	R/W	R/W
Reset	0	0	0	0	0	0	0	0

Figure 12-1. HAPI/I<sup>2</sup>C Configuration Register

**Note:** I<sup>2</sup>C-compatible function must be separately enabled as described in Section 13.0.

Bits [7:1:0] of the HAPI/I<sup>2</sup>C Configuration Register control the pin out configuration of the HAPI and I<sup>2</sup>C-compatible interfaces. Bits [5:2] are used in HAPI mode only, and are described in Section 14.0. Table 12-1 shows the HAPI port configurations, and Table 12-2 shows I<sup>2</sup>C pin location configuration options. These I<sup>2</sup>C-compatible options exist due to pin limitations in certain packages, and to allow simultaneous HAPI and I<sup>2</sup>C-compatible operation.

HAPI operation is enabled whenever either HAPI Port Width Bit (Bit 1 or 0) is non-zero. This affects GPIO operation as described in Section 14.0. I<sup>2</sup>C-compatible blocks must be separately enabled as described in Section 13.0.

**Table 12-1. HAPI Port Configuration**

Port Width (Bits[1:0])	HAPI Port Width
11	24 Bits: P3[7:0], P1[7:0], P0[7:0]
10	16 Bits: P1[7:0], P0[7:0]
01	8 Bits: P0[7:0]
00	No HAPI Interface

**Table 12-2. I<sup>2</sup>C Port Configuration**

I <sup>2</sup> C Position (Bit[7])	Port Width (Bit[1])	I <sup>2</sup> C Position
X	1	I <sup>2</sup> C on P2[1:0], 0:SCL, 1:SDA
0	0	I <sup>2</sup> C on P1[1:0], 0:SCL, 1:SDA
1	0	I <sup>2</sup> C on P2[1:0], 0:SCL, 1:SDA

### 13.0 I<sup>2</sup>C-compatible Controller

The I<sup>2</sup>C-compatible block provides a versatile two-wire communication with external devices, supporting master, slave, and multi-master modes of operation. The I<sup>2</sup>C-compatible block functions by handling the low-level signaling in hardware, and issuing interrupts as needed to allow firmware to take appropriate action during transactions. While waiting for firmware response, the hardware keeps the I<sup>2</sup>C-compatible bus idle if necessary.

The I<sup>2</sup>C-compatible block generates an interrupt to the microcontroller at the end of each received or transmitted byte, when a stop bit is detected by the slave when in receive mode, or when arbitration is lost. Details of the interrupt responses are given in Section 16.8.

The I<sup>2</sup>C-compatible interface consists of two registers, an I<sup>2</sup>C Data Register (Figure 13-1) and an I<sup>2</sup>C Status and Control Register (Figure 13-2). The Data Register is implemented as separate read and write registers. Generally, the I<sup>2</sup>C Status and Control Register should only be monitored after the I<sup>2</sup>C interrupt, as all bits are valid at that time. Polling this register at other times could read misleading bit status if a transaction is underway.

The I<sup>2</sup>C SCL clock is connected to bit 0 of GPIO port 1 or GPIO port 2, and the I<sup>2</sup>C SDA data is connected to bit 1 of GPIO port 1 or GPIO port 2. Refer to Section 12.0 for the bit definitions and functionality of the HAPI/I<sup>2</sup>C Configuration Register, which is used to set the locations of the configurable I<sup>2</sup>C-compatible pins. Once the I<sup>2</sup>C-compatible functionality is enabled by setting bit 0 of the I<sup>2</sup>C Status & Control Register, the two LSB bits ([1:0]) of the corresponding GPIO port are placed in Open Drain mode, regardless of the settings of the GPIO Configuration Register. The electrical characteristics of the I<sup>2</sup>C-compatible interface is the same as that of GPIO ports 1 and 2. Note that the I<sub>OL</sub> (max) is 2 mA @ V<sub>OL</sub> = 2.0 V for ports 1 and 2.

All control of the I<sup>2</sup>C clock and data lines is performed by the I<sup>2</sup>C-compatible block.

I <sup>2</sup> C Data								ADDRESS 0x29
Bit #	7	6	5	4	3	2	1	0
Bit Name	I <sup>2</sup> C Data 7	I <sup>2</sup> C Data 6	I <sup>2</sup> C Data 5	I <sup>2</sup> C Data 4	I <sup>2</sup> C Data 3	I <sup>2</sup> C Data 2	I <sup>2</sup> C Data 1	I <sup>2</sup> C Data 0
Read/Write	R/W	R/W	R/W	R/W	R/W	R/W	R/W	R/W
Reset	X	X	X	X	X	X	X	X

**Figure 13-1. I<sup>2</sup>C Data Register**

#### Bits [7..0] : I<sup>2</sup>C Data

Contains the 8 bit data on the I<sup>2</sup>C Bus

#### I<sup>2</sup>C Status and Control

Bit #	7	6	5	4	3	2	1	0
Bit Name	MSTR Mode	Continue/Busy	Xmit Mode	ACK	Addr	ARB Lost/Restart	Received Stop	I <sup>2</sup> C Enable
Read/Write	R/W	R/W	R/W	R/W	R/W	R/W	R/W	R/W
Reset	0	0	0	0	0	0	0	0

**Figure 13-2. I<sup>2</sup>C Status and Control Register**

The I<sup>2</sup>C Status and Control register bits are defined in Table 14-1, with a more detailed description following.