



Chipsmall Limited consists of a professional team with an average of over 10 year of expertise in the distribution of electronic components. Based in Hongkong, we have already established firm and mutual-benefit business relationships with customers from,Europe,America and south Asia,supplying obsolete and hard-to-find components to meet their specific needs.

With the principle of “Quality Parts,Customers Priority,Honest Operation,and Considerate Service”,our business mainly focus on the distribution of electronic components. Line cards we deal with include Microchip,ALPS,ROHM,Xilinx,Pulse,ON,Everlight and Freescale. Main products comprise IC,Modules,Potentiometer,IC Socket,Relay,Connector.Our parts cover such applications as commercial,industrial, and automotives areas.

We are looking forward to setting up business relationship with you and hope to provide you with the best service and solution. Let us make a better world for our industry!



Contact us

Tel: +86-755-8981 8866 Fax: +86-755-8427 6832

Email & Skype: info@chipsmall.com Web: www.chipsmall.com

Address: A1208, Overseas Decoration Building, #122 Zhenhua RD., Futian, Shenzhen, China





CYPRESS

CY7C64601/603/613

CY7C64601/603/613

EZ-USB *FX* USB Microcontroller

Data Sheet

TABLE OF CONTENTS

1.0 FEATURES	3
1.1 EZ-USB FX Features	3
1.2 Example Applications	4
2.0 FUNCTIONAL OVERVIEW	4
2.1 Microprocessor	5
2.2 USB SIE	5
2.3 Endpoints	6
2.4 Default USB Machine	7
2.5 IBN (In-Bulk-NAK) Interrupts	7
2.6 Slave FIFOs	7
2.7 DMA	8
2.8 GPIF (General Programmable Interface)	8
3.0 PIN ASSIGNMENTS	9
3.1 Pin Diagrams	9
3.2 CY7C646xx Pin Descriptions	13
4.0 REGISTER SUMMARY	22
5.0 INPUT/OUTPUT PIN SPECIAL CONSIDERATION	29
6.0 ABSOLUTE MAXIMUM RATINGS	29
7.0 OPERATING CONDITIONS	29
8.0 DC CHARACTERISTICS	29
9.0 AC ELECTRICAL CHARACTERISTICS	30
9.1 USB Transceiver	30
9.2 Program Memory Read	30
9.3 Data Memory Read	31
9.4 Data Memory Write	32
9.5 DMA Read	33
9.6 DMA Write	34
9.7 Slave FIFOs—Output Enables	34
9.8 Slave FIFOs—Synchronous Read	35
9.9 Slave FIFOs—Synchronous Write	35
9.10 Slave FIFOs—Asynchronous Read ^[9, 10]	36
9.11 Slave FIFOs—Asynchronous Write ^[9, 10]	36
9.12 GPIF Signals (Internally Clocked)	37
9.13 GPIF Signals (Externally Clocked)	37
10.0 ORDERING INFORMATION	38
11.0 PACKAGE DIAGRAMS	38
11.1 52 PQFP	38
11.2 80 PQFP	40
11.3 128 PQFP	42

1.0 Features

The CY7C646xx (EZ-USB FX) is Cypress Semiconductor's second-generation full-speed USB family. FX products offer higher performance and a higher level of integration than first-generation EZ-USB products. The FX builds on the EZ-USB feature set, including an intelligent USB core, enhanced 8051, 8-Kbyte RAM, and high-performance I/O. The CY7C646xx enhances the EZ-USB family by providing faster operation and more ways to transfer data into and out of the chip at very high speed.

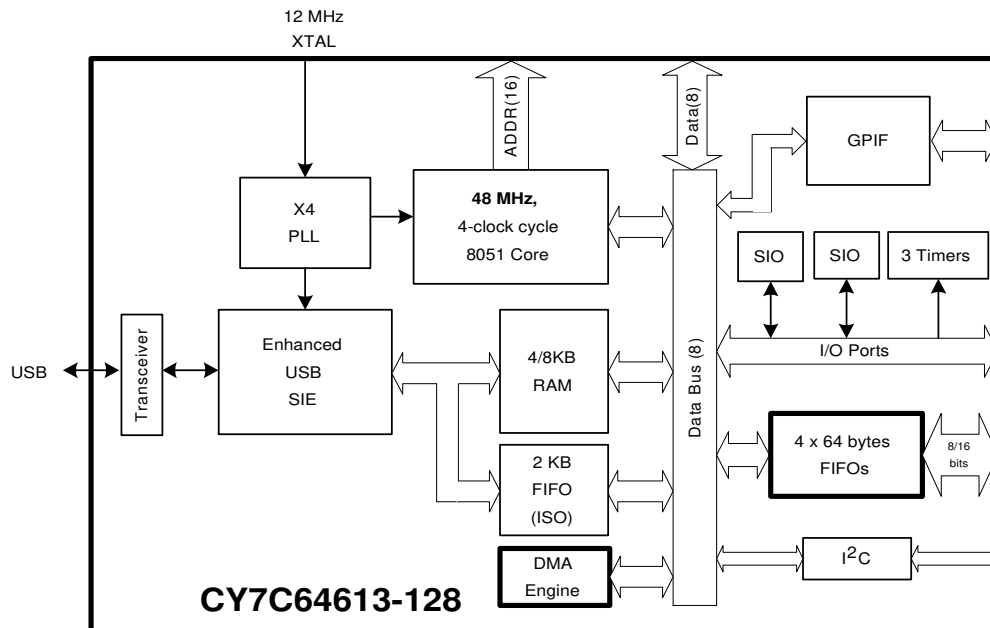

1.1 EZ-USB FX Features

- Single-chip integrated USB Transceiver, Serial Interface Engine (SIE), and Enhanced 8051 Microprocessor
- Soft: 8051 runs from internal RAM, which is:
 - Downloaded via USB, or
 - Loaded from EEPROM
- 14 Bulk/Interrupt endpoints, each with a maximum packet size of 64 bytes
- 16 Isochronous endpoints, with 2 KB of buffer space (1 KB, double buffered) which may be divided among the sixteen isochronous endpoints
- Integrated, industry standard 8051 with enhanced features:
 - Four clocks per cycle
 - Two UARTS
 - Three counter/timers
 - Expanded interrupt system
 - Two data pointers
- 3.3-volt operation
- Smart Serial Interface Engine (SIE)
- Vectored USB interrupts
- Separate buffers for the SETUP and DATA portions of a CONTROL transfer
- Integrated I²C™ controller
- 48-MHz or 24-MHz 8051 operation
- Enhanced IO
 - IO port registers mapped to SFRs
 - Port bits can be controlled using 8051 bit addressing instructions
- Four integrated general purpose 8-bit FIFOs
 - 64 bytes each
 - Automatic conversion to and from 16-bit buses

- FIFOs can use externally supplied clock
- Easy interface to ASIC and DSP ICs
- Brings glue FIFOs inside for lower system cost
- **DMA Controller**
 - Moves data between slave FIFOs, memory, and ports
 - Very fast transfers—one clock (20.8 ns) per byte for internal transfers
 - Can use external RAM as additional FIFO (addressed through A/D buses)
- **Special Autovectors for DMA and FIFO interrupts**
- **400-kHz or 100-kHz I²C operation**
- **General Programmable Interface (GPIF)**
 - Allows direct connection to most parallel interfaces: 8- and 16-bit
 - Programmable Waveform Descriptors and Configuration Registers to define waveforms
 - Supports multiple Ready (RDY) inputs and Control (CTL) outputs
- **Three package options - 128-pin PQFP, 80-pin PQFP, and 52-pin PQFP**

1.2 Example Applications

- DSL modems
- ATAPI interface
- Memory card readers
- Legacy conversion devices
- Cameras
- Scanners
- Home PNA
- Wireless LAN
- MP3 players
- Networking

2.0 Functional Overview

The CY7C646xx enhances the line of Cypress EZ-USB chips while maintaining code compatibility. The CY7C646xx builds on the feature set that has already made the EZ-USB family a popular choice for high-integration, high-speed USB applications:

- **Soft operation.** Program code can be downloaded into on-chip RAM via the USB cable, eliminating the need for external program memory or mask ROM headaches.
- **Enhanced 8051.** A speedy four clocks per cycle, plus expanded features.
- **Smart SIE.** The USB Serial Interface Engine does much of the low-level USB overhead in logic, simplifying the 8051 code.
- **DMA for very fast 8-bit or 16-bit transfers.** In the fastest (synchronous byte) mode, one byte can be transferred per 48-MHz clock, or every 20.8 nanoseconds.
- **General Programmable Interface (GPIF).** A reconfigurable 8- or 16-bit parallel interface allows the CY7C646xx to perform local bus mastering, and can implement a wide variety of protocols such as ATAPI, printer parallel port, and Utopia.
- **Abundant endpoints and buffers.** 16x64 byte buffers for bulk/interrupt/control endpoints, 2x1024 byte FIFOs for up to 16 isochronous endpoints.
- **Glueless memory expansion.** The 8051 16-bit address bus and 8-bit data bus is available, along with strobes RD#, WR#, OE# and CS#. The buses are brought out on separate pins (not multiplexed, as in the standard 8051), saving one clock per external memory cycle.
- **48-MHz or 24-MHz 8051 selectable by EEPROM configuration byte.**
- **Five 8-bit IO ports.**
- **Optimum 8051 IO efficiency.** IO pins can be addressed as external registers (as in EZ-USB) or through 8051 SFR (Special Function Register) bits for faster operation.
- **Four internal FIFOs for glueless interface to ASICs, DSPs, or external logic.** These FIFOs can be clocked either by an internal or external clock, and can operate either synchronously (using strobes and a clock) or asynchronously (using strobes only). The FIFOs have 8-16 and 16-8 bit conversion modes that simplify interface to external data buses.
- **The vectored interrupt system is expanded to accommodate the FIFO flags and DMA systems.** Also, the 8051 can clear the USB (INT2) or the FIFO/DMA (INT4) interrupt request bit for the interrupt currently being serviced by writing an SFR location, saving time and code in the interrupt service routine.
- **400-kHz or 100-kHz I²C bus controller speed.**

2.1 Microprocessor

The CY7C646xx uses a 12-MHz crystal for low EMI. An internal oscillator and PLL develops an internal 48-MHz clock for use by the USB Serial Interface Engine and the 8051 microprocessor. The 8051 can run at either 24 MHz or 48 MHz, controlled by a byte in the EEPROM attached to the I²C bus. The default rate (with no EEPROM connected) is 24 MHz.

The internal microprocessor is an enhanced version of the industry-standard 8051. Enhancements include 4 clock per cycle operation, a second data pointer, and an enhanced interrupt system. The 8051 includes two UARTS, three counter-timers, and 256 bytes of register RAM.

The EZ-USB family implements IO differently than the standard 8051, by having its IO control registers in external memory space. The CY7C646xx preserves this addressing for backward EZ-USB compatibility, and adds the ability to control IO registers using 8051 SFRs (Special Function Registers). This improves IO access time. For example, an IO pin may be toggled using one 8051 instruction, e.g., CPL (bit).

The 8051 program and data memory consists of an internal 8 KB RAM. This RAM is normally downloaded via the USB cable at plug-in, followed by the 8051 starting up and executing the downloaded code. This gives the CY7C646xx family its 'soft' operation feature, whereby permanent memory such as ROM or Flash memory is not required. Program code updates can easily be done in the field since the code is loaded from the PC, not by physically changing or reprogramming a memory device. The 8051 program memory can also be loaded from the EEPROM connected to the I²C bus on reset for stand-alone use without the USB connected.

The 128-pin version of the CY7C646xx brings out the full 8051 address and data buses, plus decoded control signals OE#, CS#, RD#, PSEN, and WR# to allow glueless connection to external memory devices. The 80- and 52-pin packages allow smaller footprints and more effective solutions for certain designs, but do not have external access to the 8051 buses.

2.2 USB SIE

The CY7C646xx uses the EZ-USB family enhanced SIE (Serial Interface Engine). This SIE has the intelligence to perform full USB enumeration, creating a default USB device with predefined endpoints and alternate settings. This enhanced SIE is essential in achieving the family's soft operation, since it provides the mechanism to download firmware prior to the 8051 running.

Once the 8051 is in control, it can use advanced features of the SIE to simplify its USB firmware. Endpoint zero SETUP data is placed in a separate 8-byte RAM space for easy access. GET_Descriptor requests are simplified by using a special Setup Data Pointer. The 8051 simply loads a descriptor address into this 16-bit register, and the SIE takes care of the remaining overhead, i.e., dividing the descriptor into packets, sending them via endpoint 0 in response to IN tokens, and providing the necessary handshakes. The 8051 can do other chores while the SIE completes this USB transfer.

2.3 Endpoints

Endpoint	Type	Buffer Size
EP0-IN EP0-OUT	Control	64 64
EP1-IN	Bulk/Interrupt	64
EP1-OUT	Bulk/Interrupt	64
EP2-IN	Bulk/Interrupt	64
EP2-OUT	Bulk/Interrupt	64
EP3-IN	Bulk/Interrupt	64
EP3-OUT	Bulk/Interrupt	64
EP4-IN	Bulk/Interrupt	64
EP4-OUT	Bulk/Interrupt	64
EP5-IN	Bulk/Interrupt	64
EP5-OUT	Bulk/Interrupt	64
EP6-IN	Bulk/Interrupt	64
EP6-OUT	Bulk/Interrupt	64
EP7-IN	Bulk/Interrupt	64
EP7-OUT	Bulk/Interrupt	64
EP8-IN	Isochronous	0–1023 ^[1]
EP8-OUT	Isochronous	0–1023 ^[1]
EP9-IN	Isochronous	0–1023 ^[1]
EP9-OUT	Isochronous	0–1023 ^[1]
EP10-IN	Isochronous	0–1023 ^[1]
EP10-OUT	Isochronous	0–1023 ^[1]
EP11-IN	Isochronous	0–1023 ^[1]
EP11-OUT	Isochronous	0–1023 ^[1]
EP12-IN	Isochronous	0–1023 ^[1]
EP12-OUT	Isochronous	0–1023 ^[1]
EP13-IN	Isochronous	0–1023 ^[1]
EP13-OUT	Isochronous	0–1023 ^[1]
EP14-IN	Isochronous	0–1023 ^[1]
EP14-OUT	Isochronous	0–1023 ^[1]
EP15-IN	Isochronous	0–1023 ^[1]
EP15-OUT	Isochronous	0–1023 ^[1]

Note:

1. 1023 FIFO bytes may be divided among all Isochronous endpoints.

The CY7C646xx has Control, Bulk, and Interrupt endpoints which each have 64-byte buffers to accommodate the maximum USB specified packet size, giving the highest USB throughput. One endpoint pair is dedicated to endpoint zero, with separate EP0-IN and EP0-OUT buffers to simplify programming. Fourteen additional 64-byte buffers may be used as Bulk or Interrupt endpoints. These endpoints may also be double-buffered by using an endpoint pairing mechanism. Double buffering allows the 8051 to access a packet as another is being transmitted or received over USB. This technique is essential in high-bandwidth applications where NAKs by the USB function would reduce performance.

The CY7C646xx also has sixteen Isochronous (ISO) endpoints which share 1024 bytes of double-buffered endpoint memory (2 KB total). The ISO buffer sizes are programmable within 16-byte increments. The Isochronous endpoint buffers are accessed as FIFOs.

Endpoint data is serviced either directly by the 8051, or moved on or off-chip using the DMA system built into the CY7C646xx. Bulk data is available in 64-byte random-access buffers that can also be addressed as a FIFO using the special AutoPointer feature. Each endpoint has a unique interrupt vector. This allows ISRs (Interrupt Service Routines) automatically to be called with minimum overhead and latency, simply by including the ISR address in an interrupt jump table.

2.4 Default USB Machine

When the CY7C64613 is plugged into USB with no EEPROM attached to its I²C port (but **with** the SCL and SDA pull-ups installed), the intelligent SIE enumerates as a generic USB device with the following characteristics:

ID bytes (hex)

VID (Vendor ID)	0547
PID (Product ID)	2235
DID (Device ID)	0000

Default Endpoints

Endpoint	Type	Alternate Setting		
		0	1	2
		Max Packet Size (bytes)		
0	CTL	64	64	64
1 IN	INT	0	16	64
2 IN	BULK	0	64	64
2 OUT	BULK	0	64	64
4 IN	BULK	0	64	64
4 OUT	BULK	0	64	64
6 IN	BULK	0	64	64
6 OUT	BULK	0	64	64
8 IN	ISO	0	16	256
8 OUT	ISO	0	16	256
9 IN	ISO	0	16	16
9 OUT	ISO	0	16	16
10 IN	ISO	0	16	16
10 OUT	ISO	0	16	16

Powering up with default USB characteristics allows code to be written without initial consideration of the enumeration code that establishes the default USB device, speeding the learning process.

2.5 IBN (In-Bulk-NAK) Interrupts

The CY7C646xx has an interrupt that indicates that an IN token has been received by an endpoint, and the SIE has NAK'd the transfer due to no data being available in the endpoint buffer. Interrupt request bits are provided for endpoints EP1IN through EP7IN, and a previously reserved vector is added to the USB vectored interrupts.

2.6 Slave FIFOs

Many high-bandwidth USB designs use a FIFO between the USB interface chip and external logic to match data rates, or to smooth the USB data delivery (which, being packet oriented, occurs in bursts). The CY7C646xx moves this glue logic into the part by providing four 64-byte internal slave FIFOs. The FIFOs also provide two important interface functions, external clocking and bus width conversion.

Using external clocking, external logic (such as a DSP or ASIC) can clock data into or out of the slave FIFOs under control of its own clock, rather than synchronizing with the clock supplied by the CY7C646xx (24 or 48 MHz). The FIFOs can be controlled

either synchronously (using strobe signals and a clock) or asynchronously (using strobe signals only). The slave FIFO data is available as two 8-bit buses, which may be used simultaneously to operate as a single 16-bit data bus. The 16-bit connection, along with fast double-byte mode, combine to give fast conversion between 8 and 16 bit buses. A flexible set of FIFO flags (full, empty, and programmable) provide FIFO flow control.

2.7 DMA

With many sources and destinations for USB data, such as endpoint buffers, slave FIFOs, and internal/external RAM buffers, it is important to move blocks of data between them quickly. Using internal DMA, the 8051 sets up source, destination, and transfer length registers, and then initiates a DMA transfer. The maximum DMA transfer rate occurs between internal resources, such as endpoint buffers and slave FIFOs. This maximum rate is one byte per 48-MHz clock, or 48 Mbytes per second.

2.8 GPIF (General Programmable Interface)

The GPIF is a flexible 8 or 16-bit parallel interface driven by a user-programmable set of vectors that operate similarly to a finite state machine. It allows the CY7C646xx to perform local bus mastering, and can implement a wide variety of protocols such as ATAPI, printer parallel port, and Utopia.

The GPIF has six programmable Control Outputs (CTL), six Address Outputs (ADR), and six general purpose Ready Inputs (RDY). The data bus width can be 8 or 16 bits. Each GPIF vector defines the state of the control outputs, or determines what state a ready input (or multiple inputs) must be before proceeding. A sequence of the GPIF vectors make up a single waveform that will be executed to perform the desired data move between the CY7C646xx and the external design.

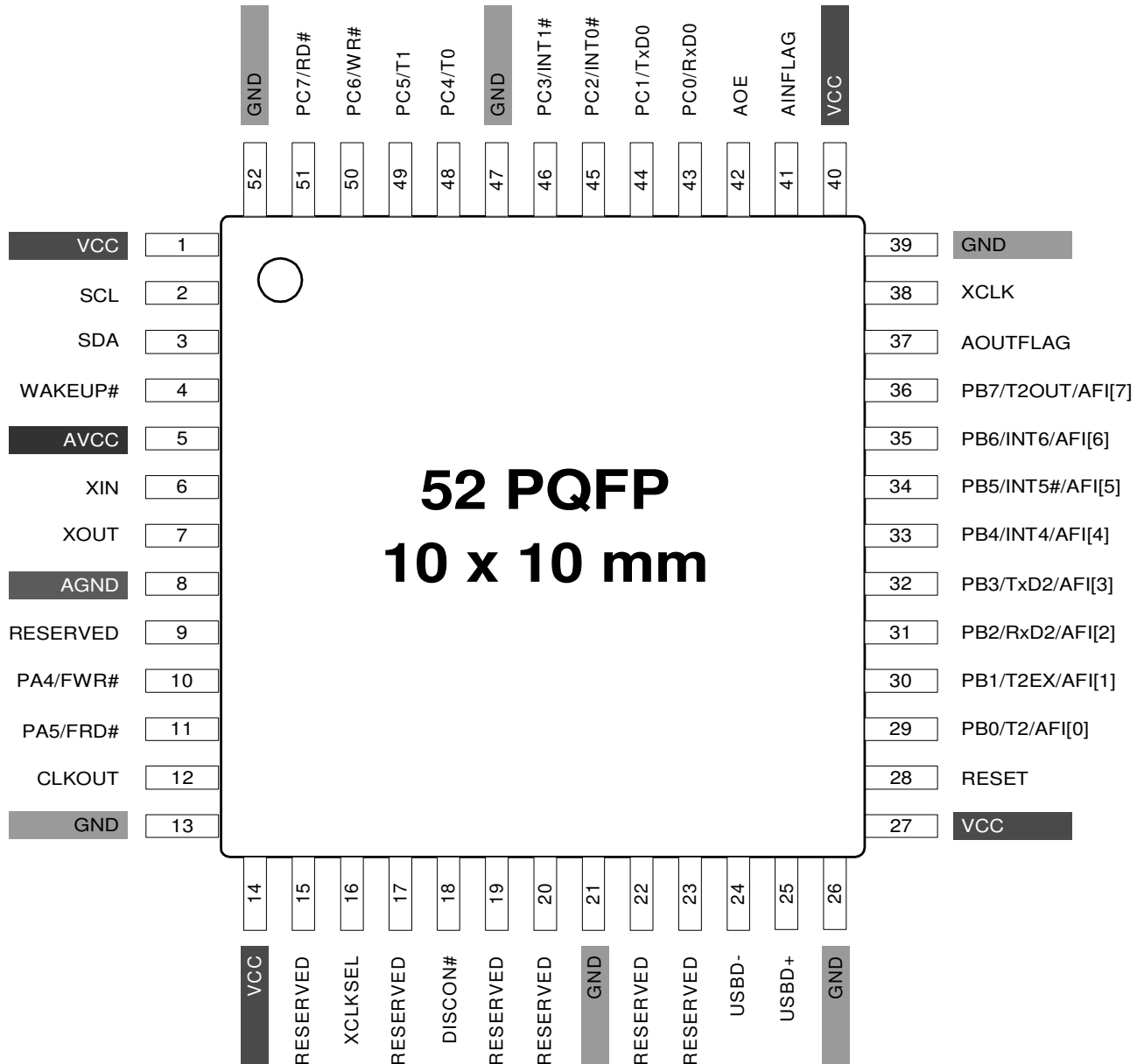
3.0 Pin Assignments
3.1 Pin Diagrams

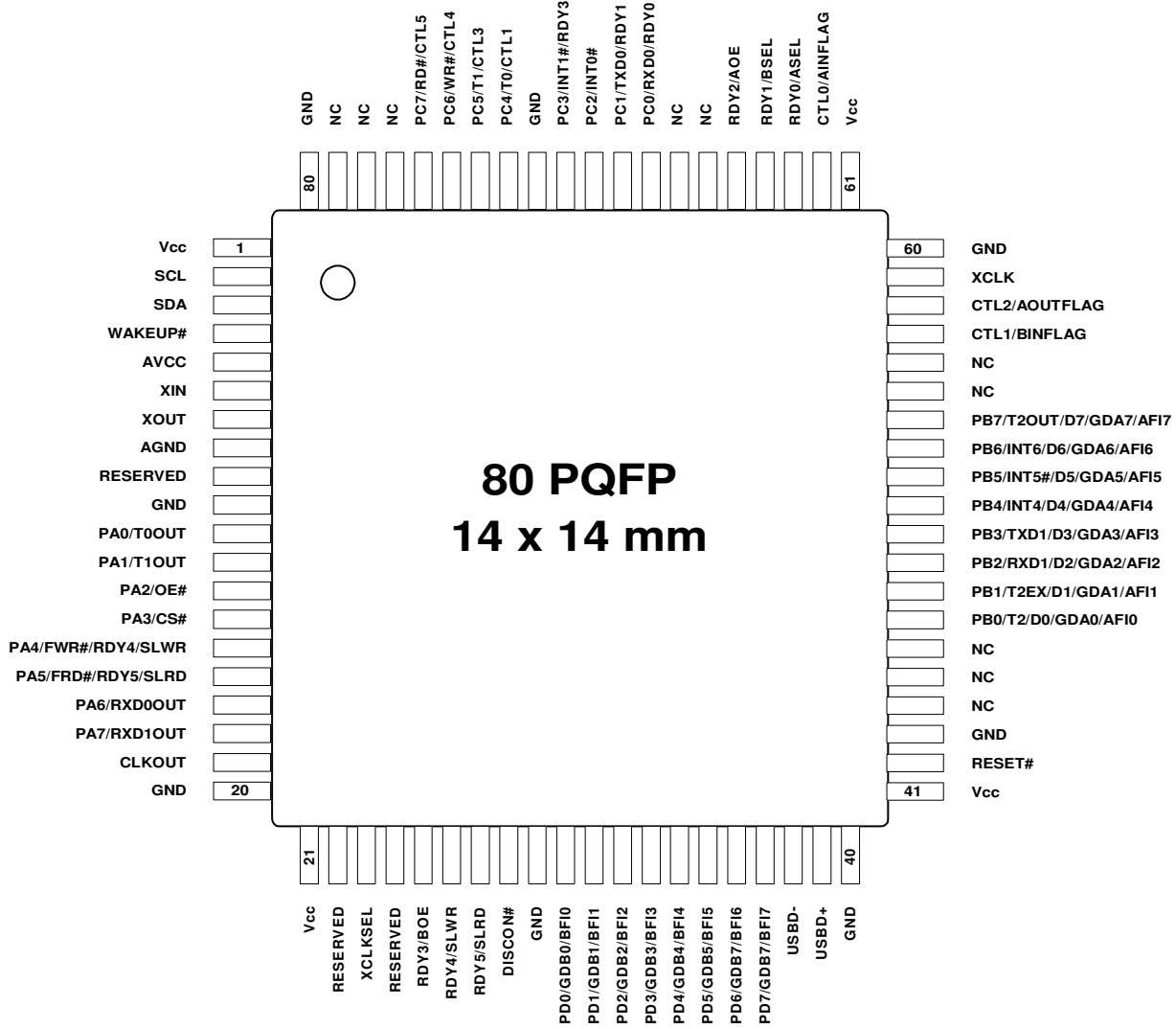

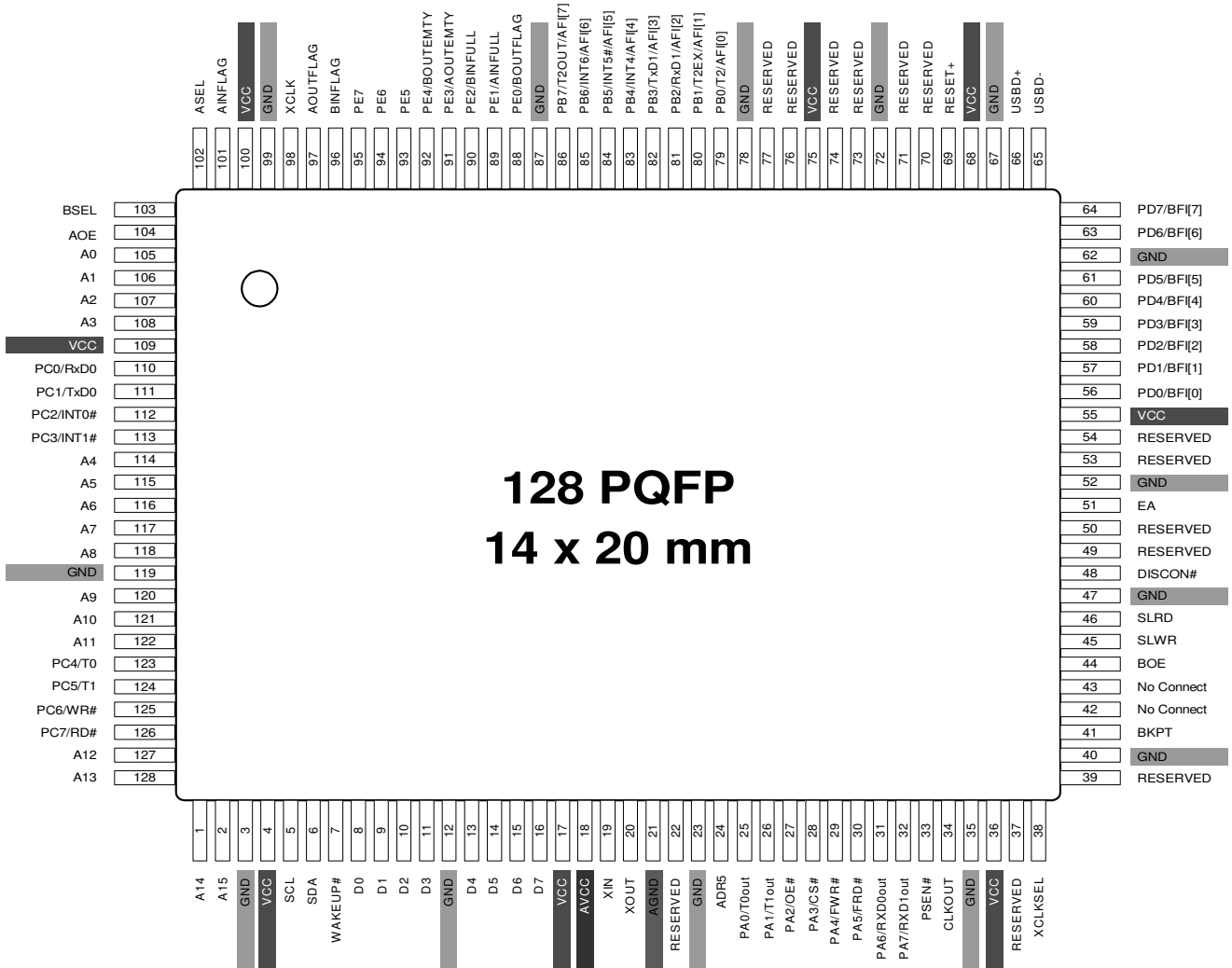

3.2 CY7C646xx Pin Descriptions

128	80	52	Name	Type	Default	Description
18	5	5	AVCC	Power	N/A	Analog V_{CC} . This signal provides power to the analog section of the chip.
21	8	8	AGND	Power	N/A	Analog Ground . Connect to ground with as short a path as possible.
48	28	18	DISCON#	O/Z	H	Disconnect . This pin can drive HIGH, LOW, or float. DISCON# pin floats when the register bit USBCS.2 is LOW, and drives when it is HIGH. The drive level of the DISCON# pin is the invert of register bit USBCS.3. The DISCON# pin is normally connected to the USB D+ line through a 1500Ω resistor. The CY7C646xx signals a USB connection by setting USBCS.3=0 (drive 3.3V) and USBCS.2=1 (output enable). The CY7C646xx signals a USB disconnect by setting USBCS.2=0 which floats the pin and disconnects the 1500Ω resistor from D+.

3.2 CY7C646xx Pin Descriptions (continued)

128	80	52	Name	Type	Default	Description
65	38	24	USBD-	I/O/Z	Z	USB D- Signal. Connect to the USB D- signal through a 24Ω resistor.
66	39	25	USBD+	I/O/Z	Z	USB D+ Signal. Connect to the USB D+ pin through a 24Ω resistor.
105			A0	Output	L	8051 Address Bus. This bus is driven at all times. When the 8051 is addressing internal RAM it reflects the internal address. During DMA transfers that use the RD# and WR# strobes, the address bus contains the incrementing DMA source or destination address for data transferred over D[7..0].
106			A1	Output	L	
107			A2	Output	L	
108			A3	Output	L	
114			A4	Output	L	
115			A5	Output	L	
116			A6	Output	L	
117			A7	Output	L	
118			A8	Output	L	
120			A9	Output	L	
121			A10	Output	L	
122			A11	Output	L	
127			A12	Output	L	
128			A13	Output	L	
1			A14	Output	L	
2			A15	Output	L	
8			D0	I/O/Z	Z	8051 Data Bus. This bidirectional bus is high-impedance when inactive, input for bus reads, and output for bus writes. The data bus is used for external 8051 program and data memory. The data bus is also used for DMA transfers that use the RD#/FRD#, WR#,FWR# pins as strobes. The data bus is active only for external bus accesses, and is driven LOW in suspend.
9			D1	I/O/Z	Z	
10			D2	I/O/Z	Z	
11			D3	I/O/Z	Z	
13			D4	I/O/Z	Z	
14			D5	I/O/Z	Z	
15			D6	I/O/Z	Z	
16			D7	I/O/Z	Z	
33			PSEN#	Output	H	
41			BKPT	Output	L	Breakpoint. This pin goes active (HIGH) when the 8051 address bus matches the BPADDRH/L registers and breakpoints are enabled in the USBBAV register (BPEN=1). If the BPPULSE bit in the USBBAV register is HIGH, this signal pulses HIGH for eight 24-/48-MHz clocks. If the BPPULSE bit is LOW, the signal remains HIGH until the 8051 clears the BREAK bit (by writing 1 to it) in the USBBAV register.
69	42	28	RESET#	Input	N/A	Active LOW Reset. Resets the entire chip. This pin is normally tied to V _{CC} through a 10K resistor, and to GND through a 1-μF capacitor. Hysteresis input.
51			EA	Input	N/A	External Access. This pin determines where the 8051 fetches code between addresses 0x0000 and 0x1B3F. If EA=0 the 8051 fetches this code from its internal RAM. IF EA=1 the 8051 fetches this code from external memory.

3.2 CY7C646xx Pin Descriptions (continued)

128	80	52	Name	Type	Default	Description
19	6	6	XIN	Input	N/A	Crystal Input. Connect this signal to a 12-MHz series-resonant, fundamental mode crystal and 22–33 pF capacitor to GND. Also connect a 1-M Ω resistor between XIN and XOUT.
20	7	7	XOUT	Output	N/A	Crystal Output. Connect this signal to a 12-MHz series-resonant, fundamental mode crystal and 22–33 pF capacitor to GND. Also connect a 1-M Ω resistor between XIN and XOUT.
34	19	12	CLKOUT	O/Z	24 MHz	24- or 48-MHz clock, phase locked to the 12-MHz input clock. Output frequency is set by an external EEPROM bit (Config0.2). If no EEPROM is connected to the I ² C port (but the required pull-up resistors are present), the 8051 defaults to 24-MHz operation. The 8051 may three-state this output by setting CPUCS.1=1. The CLKOUT pin may be inverted by setting the boot EEPROM bit CONFIG0.1=1.
Port A						
25	11		PA0 or T0OUT	I/O/Z	I (PA0)	Multiplexed pin whose function is selected by two bits: PORTACFG.0 and IFCONFIG.3. PA0 is a bidirectional IO port pin. T0OUT is an active-HIGH signal from 8051 Timer-counter0. T0OUT outputs a high level for one CLKOUT clock cycle when Timer0 overflows. If Timer0 is operated in mode 3 (two separate timer/counters), T0OUT is active when the low byte timer/counter overflows.
26	12		PA1 or T1OUT	I/O/Z	I (PA1)	Multiplexed pin whose function is selected by two bits: PORTACFG.1 and IFCONFIG.3. PA1 is a bidirectional IO port pin. T1OUT is an active-HIGH signal from 8051 Timer-counter1. T1OUT outputs a high level for one CLKOUT clock cycle when Timer1 overflows. If Timer1 is operated in mode 3 (two separate timer/counters), T1OUT is active when the low byte timer/counter overflows.
27	13		PA2 or OE# or	I/O/Z	I (PA2)	Multiplexed pin whose function is selected by two bits: PORTACFG.2 and IFCONFIG.3. PA2 is a bidirectional IO port pin. OE# is an active-LOW output enable for external memory. If the OE# pin is used, it should be externally pulled up to V _{CC} to ensure that the write strobe is inactive (high) at power-on.
28	14		PA3 or CS#	I/O/Z	I (PA3)	Multiplexed pin whose function is selected by the PORTACFG.3 bit. PA3 is a bidirectional I/O port pin. CS# is an active-LOW chip select for external memory. If the CS# pin is used, it should be externally pulled up to V _{CC} to ensure that the write strobe is inactive (HIGH) at power-on.
29	15	10	PA4 or FWR# or RDY4 or SLWR	I/O/Z	I (PA4)	Multiplexed pin whose function is selected by the following bits: PORTACFG.4, PORTACF2.4, and IFCONFIG[1..0]. PA4 is a bidirectional I/O port pin. FWR# is the write strobe output for an external FIFO connected to the data bus D[7..0]. If the FWR# pin is used, it should be externally pulled up to V _{CC} to ensure that the write strobe is inactive at power-on. RDY4 is a GPIF input signal. SLWR is the write strobe input for the slave FIFOs connected to AFI[7..0] and/or BFI[7..0].

3.2 CY7C646xx Pin Descriptions (continued)

128	80	52	Name	Type	Default	Description
30	16	11	PA5 or FRD# or RDY5 or SLRD	I/O/Z	I (PA5)	Multiplexed pin whose function is selected by the following bits: PORTACFG.5, PORTACF2.5, and IFCONFIG[1..0]. PA5 is a bidirectional I/O port pin. FRD# is the write strobe output for an external FIFO connected to the data bus D[7..0]. If the FRD# pin is used, it should be externally pulled up to V _{CC} to ensure that the read strobe is inactive at power-on. RDY5 is a GPIF input signal. SLRD is the read strobe input for the slave FIFOs connected to AFI[7..0] and/or BFI[7..0].
31	17		PA6 or RXD0OUT	I/O/Z	I (PA6)	Multiplexed pin whose function is selected by the PORTACFG.6 bit. PA6 is a bidirectional I/O port pin. RXD0OUT is an active-HIGH signal from 8051 UART0. If RXD0OUT is selected and UART0 is in mode 0, this pin provides the output data for UART0 only when it is in sync mode. Otherwise it is a 1.
32	18		PA7 or RXD1OUT	I/O/Z	I (PA7)	Multiplexed pin whose function is selected by the PORTACFG.7 bit. PA7 is a bidirectional I/O port pin. RXD1OUT is an active-HIGH output from 8051 UART1. When RXD1OUT is selected and UART1 is in mode 0, this pin provides the output data for UART1 only when it is in sync mode. In modes 1, 2, and 3, this pin is HIGH.
Port B						
						The following descriptions apply to the PORT B pins: D[7..0] is the 8051 data bus. This bus is optionally available on PORT B pins to provide access to the 8051 data bus in smaller EZ-USB II packages that do not bring out the 8051 address and data buses. GDA[7..0] is the GPIF A data bus. AFI[7..0] is the bidirectional A-FIFO data bus.
79	47	29	PB0 or T2 or D[0] or GDA[0] or AFI [0]	I/O/Z	I (PB0)	Multiplexed pin whose function is selected by the following bits: PORTBCFG.0 and IFCONFIG[1..0]. PB0 is a bidirectional I/O port pin. T2 is the active-HIGH T2 input signal to 8051 Timer2, which provides the input to Timer2 when C/T2=1. When C/T2=0, Timer2 does not use this pin. AFI [0] is the bidirectional A-FIFO data bus.
80	48	30	PB1 or T2EX or D[1] or GDA[1] or AFI [1]	I/O/Z	I (PB1)	Multiplexed pin whose function is selected by the following bits: PORTBCFG.1 and IFCONFIG[1..0]. PB1 is a bidirectional I/O port pin. T2EX is an active-HIGH input signal to the 8051 Timer2. T2EX reloads timer 2 on its falling edge. T2EX is active only if the EXEN2 bit is set in T2CON. AFI [1] is the bidirectional A-FIFO data bus.
81	49	31	PB2 or RXD1 or D[2] or GDA[2] or AFI [2]	I/O/Z	I (PB2)	Multiplexed pin whose function is selected by the following bits: PORTBCFG.2 and IFCONFIG[1..0]. PB2 is a bidirectional I/O port pin. RXD1 is an active-HIGH input signal for 8051 UART1, which provides data to the UART in all modes. AFI [2] is the bidirectional A-FIFO data bus.

3.2 CY7C646xx Pin Descriptions (continued)

128	80	52	Name	Type	Default	Description
82	50	32	PB3 or TXD1 or D[3] or GDA[3] or AFI [3]	I/O/Z	I (PB3)	Multiplexed pin whose function is selected by the following bits: PORTBCFG.3 and IFCONFIG[1..0]. PB3 is a bidirectional I/O port pin. TXD1 is an active-HIGH output pin from 8051 UART1, which provides the output clock in sync mode, and the output data in async mode. AFI [3] is the bidirectional A-FIFO data bus.
83	51	33	PB4 or INT4 or D[4] or GDA[4] or AFI [4]	I/O/Z	I (PB4)	Multiplexed pin whose function is selected by the following bits: PORTBCFG.4 and IFCONFIG[1..0]. PB4 is a bidirectional I/O port pin. INT4 is the 8051 INT4 interrupt request input signal. The INT4 pin is edge-sensitive, active HIGH. AFI [4] is the bidirectional A-FIFO data bus.
84	52	34	PB5 or INT5# or D[5] or GDA[5] or AFI [5]	I/O/Z	I (PB5)	Multiplexed pin whose function is selected by the following bits: PORTBCFG.5 and IFCONFIG[1..0]. PB5 is a bidirectional I/O port pin. INT5# is the 8051 INT5 interrupt request input signal. The INT5 pin is edge-sensitive, active LOW. AFI [5] is the bidirectional A-FIFO data bus.
85	53	35	PB6 or INT6 or D[6] or GDA[6] or AFI [6]	I/O/Z	I (PB6)	Multiplexed pin whose function is selected by the following bits: PORTBCFG.6 and IFCONFIG[1..0]. PB6 is a bidirectional I/O port pin. INT6 is the 8051 INT5 interrupt request input signal. The INT6 pin is edge-sensitive, active HIGH. AFI [6] is the bidirectional A-FIFO data bus.
86	54	36	PB7 or T2OUT or D[7] or GDA[7] or AFI [7]	I/O/Z	I (PB7)	Multiplexed pin whose function is selected by the following bits: PORTBCFG.7 and IFCONFIG[1..0]. PB7 is a bidirectional I/O port pin. T2OUT is the active-HIGH output signal from 8051 Timer2. T2OUT is active (HIGH) for one clock cycle when Timer/Counter 2 overflows. AFI [7] is the bidirectional A-FIFO data bus.
Port C						
110	68	43	PC0 or RXD0 or RDY0	I/O/Z	I (PC0)	Multiplexed pin whose function is selected by the PORTCCFG.0 and PORTCGPIF.0 bits. PC0 is a bidirectional I/O port pin. RXD0 is the active-HIGH RXD0 input to 8051 UART0, which provides data to the UART in all modes. RDY0 is a GPIF input signal.
111	69	44	PC1 or TXD0 or RDY1	I/O/Z	I (PC1)	Multiplexed pin whose function is selected by the PORTCCFG.1 and PORTCGPIF.1 bits. PC1 is a bidirectional I/O port pin. TXD0 is the active-HIGH TXD0 output from 8051 UART0, which provides the output clock in sync mode, and the output data in async mode. RDY1 is a GPIF input signal.
112	70	45	PC2 or INT0#	I/O/Z	I (PC2)	Multiplexed pin whose function is selected by the PORTCCFG.2 bit. PC2 is a bidirectional I/O port pin. INT0# is the active-LOW 8051 INT0 interrupt input signal, which is either edge triggered (IT0 = 1) or level triggered (IT0 = 0).
113	71	46	PC3 or INT1# or RDY3	I/O/Z	I (PC3)	Multiplexed pin whose function is selected by the: PORTCCFG.3 and PORTCGPIF.3 bits. PC3 is a bidirectional I/O port pin. INT1# is the active-LOW 8051 INT1 interrupt input signal, which is either edge triggered (IT1 = 1) or level triggered (IT1 = 0). RDY3 is a GPIF input signal.

3.2 CY7C646xx Pin Descriptions (continued)

128	80	52	Name	Type	Default	Description
123	73	48	PC4 or T0 or CTL1	I/O/Z	I (PC4)	Multiplexed pin whose function is selected by the PORTCCFG.4 and PORTCGPIF.4 bits. PC4 is a bidirectional I/O port pin. T0 is the active-HIGH T0 signal for 8051 Timer0, which provides the input to Timer0 when C/T0 is 1. When C/T0 is 0, Timer0 does not use this bit. CTL1 is a GPIF output signal.
124	74	49	PC5 or T1 or CTL3	I/O/Z	I (PC5)	Multiplexed pin whose function is selected by the PORTCCFG.5 and PORTCGPIF.5 bits. PC5 is a bidirectional I/O port pin. T1 is the active-HIGH T1 signal for 8051 Timer1, which provides the input to Timer1 when C/T1 is 1. When C/T1 is 0, Timer1 does not use this bit. CTL3 is a GPIF output signal.
125	75	50	PC6 or WR# or CTL4	I/O/Z	I (PC6)	Multiplexed pin whose function is selected by the PORTCCFG.6 and PORTCGPIF.6 bits. PC6 is a bidirectional I/O port pin. WR# is the active-LOW write strobe output for external memory. If the WR# signal is used, it should be externally pulled up to V _{CC} to ensure that the write strobe is inactive at power-on. CTL4 is a GPIF output signal.
126	76	51	PC7 or RD# or CTL5	I/O/Z	I (PC7)	Multiplexed pin whose function is selected by the PORTCCFG.7 and PORTCGPIF.7 bits. PC7 is a bidirectional I/O port pin. RD# is the active-LOW read strobe output for external memory. If the RD# signal is used, it should be externally pulled up to V _{CC} to ensure that the write strobe is inactive at power-on. CTL5 is a GPIF output signal.

Port D

						Port D is multiplexed between three sources: PD0–PD7 are bidirectional I/O port pins. GDB[7..0] is the GPIF B data bus. BFI[7..0] is the bidirectional B-FIFO data bus.
56	30		PD0 or GDB[0] or BFI [0]	I/O/Z	I (PD0)	Multiplexed pin whose function is selected by the IFCONFIG[2..0] bits. BFI [0] is the bidirectional B-FIFO data bus.
57	31		PD1 or GDB[1] or BFI [1]	I/O/Z	I (PD1)	Multiplexed pin whose function is selected by the IFCONFIG[2..0] bits. BFI [1] is the bidirectional B-FIFO data bus.
58	32		PD2 or GDB[2] or BFI [2]	I/O/Z	I (PD2)	Multiplexed pin whose function is selected by the IFCONFIG[2..0] bits. BFI [2] is the bidirectional B-FIFO data bus.
59	33		PD3 or GDB[3] or BFI [3]	I/O/Z	I (PD3)	Multiplexed pin whose function is selected by the IFCONFIG[2..0] bits. BFI [3] is the bidirectional B-FIFO data bus.
60	34		PD4 or GDB[4] or BFI [4]	I/O/Z	I (PD4)	Multiplexed pin whose function is selected by the IFCONFIG[2..0] bits. BFI [4] is the bidirectional B-FIFO data bus.
61	35		PD5 or GDB[5] or BFI [5]	I/O/Z	I (PD5)	Multiplexed pin whose function is selected by the IFCONFIG[2..0] bits. BFI [5] is the bidirectional B-FIFO data bus.
63	36		PD6 or GDB[6] or BFI [6]	I/O/Z	I (PD6)	Multiplexed pin whose function is selected by the IFCONFIG[2..0] bits. BFI [6] is the bidirectional B-FIFO data bus.

3.2 CY7C646xx Pin Descriptions (continued)

128	80	52	Name	Type	Default	Description
64	37		PD7 or GDB[7] or BFI [7]	I/O/Z	I (PD7)	Multiplexed pin whose function is selected by the IFCONFIG[2..0] bits. BFI [7] is the bidirectional B-FIFO data bus.
Port E						
88			PE0 or ADR0 or BOUTFLAG	I/O/Z	I (PE0)	Multiplexed pin whose function is selected by the IFCONFIG[2..0] bits. PE0 is a bidirectional I/O port pin. ADR0 is a GPIF address output pin. BOUTFLAG is the B-OUT FIFO flag output, which indicates a programmable level of FIFO fullness.
89			PE1 or ADR1 or AINFULL	I/O/Z	I (PE1)	Multiplexed pin whose function is selected by the IFCONFIG[2..0] bits. PE1 is a bidirectional I/O port pin. ADR1 is a GPIF address output pin. AINFULL is the A-IN FIFO flag output, which indicates FIFO full.
90			PE2 or ADR2 or BINFULL	I/O/Z	I (PE2)	Multiplexed pin whose function is selected by the IFCONFIG[2..0] bits. PE2 is a bidirectional I/O port pin. ADR2 is a GPIF address output pin. BINFULL is the B-IN FIFO flag output, which indicates FIFO full.
91			PE3 or ADR3 or AOUTEMTY	I/O/Z	I (PE3)	Multiplexed pin whose function is selected by the IFCONFIG[2..0] bits. PE3 is a bidirectional I/O port pin. ADR3 is a GPIF address output pin. AOUTEMTY is the A-OUT FIFO flag output, which indicates FIFO empty.
92			PE4 or ADR4 or BOUTEMTY	I/O/Z	I (PE4)	Multiplexed pin whose function is selected by the IFCONFIG[2..0] bits. PE4 is a bidirectional I/O port pin. ADR4 is a GPIF address output pin. BOUTEMTY is the B-OUT FIFO flag output, which indicates FIFO empty.
93			PE5 or CTL3	I/O/Z	I (PE5)	Multiplexed pin whose function is selected by the following bits: IFCONFIG[1..0]. PE5 is a bidirectional I/O port pin. CTL3 is a GPIF output signal.
94			PE6 or CTL4	I/O/Z	I (PE6)	Multiplexed pin whose function is selected by the following bits: IFCONFIG[1..0]. PE6 is a bidirectional I/O port pin. CTL4 is a GPIF output signal.
95			PE7 or CTL5	I/O/Z	I (PE7)	Multiplexed pin whose function is selected by the following bits: IFCONFIG[1..0]. PE7 is a bidirectional I/O port pin. CTL5 is a GPIF output signal.
24			ADR5	O	X	ADR5 is a GPIF address output pin.
102	63		RDY0 or ASEL	Input	X	Multiplexed pin whose function is selected by the following bits: IFCONFIG[1..0]. RDY0 is a GPIF input signal. ASEL is the select input for the A-IN and A-OUT FIFOs.
103	64		RDY1 or BSEL	Input	X	Multiplexed pin whose function is selected by the following bits: IFCONFIG[1..0]. RDY1 is a GPIF input signal. BSEL is the select input for the B-IN and B-OUT FIFOs.

3.2 CY7C646xx Pin Descriptions (continued)

128	80	52	Name	Type	Default	Description
104	65	42	RDY2 or AOE	Input	X	Multiplexed pin whose function is selected by the following bits: IFCONFIG[1..0]. RDY2 is a GPIF input signal. AOE is the output enable input for the A-OUT FIFO.
44	25		RDY3 or BOE	Input	X	Multiplexed pin whose function is selected by the following bits: IFCONFIG[1..0]. RDY3 is a GPIF input signal. BOE is the output enable input for the B-OUT FIFO.
45	26		RDY4 or SLWR	Input	X	Multiplexed pin whose function is selected by the following bits: IFCONFIG[1..0]. RDY4 is a GPIF input signal. SLWR is the input-only write strobe for the slave FIFOs connected to AFI[7..0] and/or BFI[7..0].
46	27		RDY5 or SLRD	Input	X	Multiplexed pin whose function is selected by the following bits: IFCONFIG[1..0]. RDY5 is a GPIF input signal. SLRD is the input-only read strobe for the slave FIFOs connected to AFI[7..0] and/or BFI[7..0].
101	62	41	CTL0 or AINFLAG	Output	X	Multiplexed pin whose function is selected by the following bits: IFCONFIG[1..0]. CTL0 is a GPIF control output. AINFLAG is the A-IN FIFO flag output which indicates a programmable level of FIFO fullness.
96	57		CTL1 or BINFLAG	Output	X	Multiplexed pin whose function is selected by the following bits: IFCONFIG[1..0]. CTL1 is a GPIF control output. BINFLAG is the B-IN FIFO flag output which indicates a programmable level of FIFO fullness.
97	58	37	CTL2 or AOUTFLAG	Output	X	Multiplexed pin whose function is selected by the following bits: IFCONFIG[1..0]. CTL2 is a GPIF control output. AOUTFLAG is the A-OUT FIFO flag output which indicates a programmable level of FIFO fullness.
98	59	38	XCLK	Input	N/A	External clock input, used for synchronously clocking data into the slave FIFOs. XCLK also serves as a timing reference for all slave FIFO control signals and GPIF.
53		22	Reserved	Rsrvd	N/A	Reserved. Connect to Ground.
54		23	Reserved	Rsrvd	N/A	Reserved. Connect to Ground.
70			Reserved	Rsrvd	N/A	Reserved. Connect to Ground.
71			Reserved	Rsrvd	N/A	Reserved. Connect to Ground.
73			Reserved	Rsrvd	N/A	Reserved. Connect to Ground.
74			Reserved	Rsrvd	N/A	Reserved. Connect to Ground.
76			Reserved	Rsrvd	N/A	Reserved. Connect to Ground.
77			Reserved	Rsrvd	N/A	Reserved. Connect to Ground.
50		20	Reserved	Rsrvd	N/A	Reserved. Leave open.
49		19	Reserved	Rsrvd	N/A	Reserved. Connect to Ground.
7	4	4	WAKEUP#	Input	N/A	USB Wakeup. If the 8051 is in suspend, a HIGH-to-LOW edge on this pin starts up the oscillator and interrupts the 8051 to allow it to exit the suspend mode. Holding WAKEUP# LOW inhibits the EZ-USB chip from suspending.
5	2	2	SCL	OD	Z	I²C Clock. Connect to V _{CC} with a 1K resistor, even if no I²C peripheral is attached.

3.2 CY7C646xx Pin Descriptions (continued)

128	80	52	Name	Type	Default	Description
6	3	3	SDA	OD	Z	I²C Data. Connect to V _{CC} with a 1K resistor, even if no I²C peripheral is attached.
38	23	16	XCLKSEL	Input	N/A	HIGH: Use XCLK pin for GPIF and slave FIFOs. LOW: Use internal 48-MHz clock for GPIF and slave FIFOs.
39	24	17	Reserved	Rsrvd	N/A	Reserved. Connect to Ground.
37	22	15	Reserved	Rsrvd	N/A	Reserved. Connect to Ground.
22	9	9	Reserved	Rsrvd	N/A	Reserved. Connect to Ground.
4	1	1	V _{CC}	Power	N/A	V _{CC} . Connect to 3.3 V power source.
17			V _{CC}	Power	N/A	V _{CC} . Connect to 3.3 V power source.
36	21	14	V _{CC}	Power	N/A	V _{CC} . Connect to 3.3 V power source.
55			V _{CC}	Power	N/A	V _{CC} . Connect to 3.3 V power source.
68	41	27	V _{CC}	Power	N/A	V _{CC} . Connect to 3.3 V power source.
75			V _{CC}	Power	N/A	V _{CC} . Connect to 3.3 V power source.
100	61	40	V _{CC}	Power	N/A	V _{CC} . Connect to 3.3 V power source.
109			V _{CC}	Power	N/A	V _{CC} . Connect to 3.3 V power source.
3	80	52	GND	Ground	N/A	Ground.
12			GND	Ground	N/A	Ground.
23	10		GND	Ground	N/A	Ground.
35	20	13	GND	Ground	N/A	Ground.
40			GND	Ground	N/A	Ground.
47			GND	Ground	N/A	Ground.
52	29	21	GND	Ground	N/A	Ground.
62			GND	Ground	N/A	Ground.
67	40	26	GND	Ground	N/A	Ground.
72	43		GND	Ground	N/A	Ground.
78			GND	Ground	N/A	Ground.
87			GND	Ground	N/A	Ground.
99	60	39	GND	Ground	N/A	Ground.
119	72	47	GND	Ground	N/A	Ground.
42	79		NC	N/A	N/A	No-connect. This pin must be left open.
43	44		NC	N/A	N/A	No-connect. This pin must be left open.
	45		NC	N/A	N/A	No-connect. This pin must be left open.
	46		NC	N/A	N/A	No-connect. This pin must be left open.
	55		NC	N/A	N/A	No-connect. This pin must be left open.
	56		NC	N/A	N/A	No-connect. This pin must be left open.
	66		NC	N/A	N/A	No-connect. This pin must be left open.
	67		NC	N/A	N/A	No-connect. This pin must be left open.
	77		NC	N/A	N/A	No-connect. This pin must be left open.
	78		NC	N/A	N/A	No-connect. This pin must be left open.

4.0 Register Summary

Addr	Name	Description	D7	D6	D5	D4	D3	D2	D1	D0
FIFO A-IN										
7800	AINDATA	Read Data from FIFO A	D7	D6	D5	D4	D3	D2	D1	D0
7801	AINBC	Input FIFO A Byte Count	0	D6	D5	D4	D3	D2	D1	D0
7802	AINPF	FIFO A-IN Prog. Flag (internal bit)	LTGT	D6	D5	D4	D3	D2	D1	D0
7803	AINPFPIN	FIFO A-IN Prog. Flag (external pin)	LTGT	D6	D5	D4	D3	D2	D1	D0
7804 (reserved)										
FIFO B-IN										
7805	BINDATA	Read Data from FIFO B	D7	D6	D5	D4	D3	D2	D1	D0
7806	BINBC	Input FIFO B Byte Count	0	D6	D5	D4	D3	D2	D1	D0
7807	BINPF	FIFO B-IN Prog. Flag (internal bit)	LTGT	D6	D5	D4	D3	D2	D1	D0
7808	BINPFPIN	FIFO B-IN Prog. Flag (external pin)	LTGT	D6	D5	D4	D3	D2	D1	D0
7809 (reserved)										
FIFO A/B-IN Control										
780A	ABINTF	Input FIFOs Toggle control and flags	INTOG	INSEL	AINPF	AINEF	AINFF	BINPF	BINEF	BINFF
780B	ABINIE	Input FIFO Interrupt Enables	0	0	AINPFIE	AINEFIE	AINFFIE	BINPFIE	BINEFIE	BINFFIE
780C	ABINIRQ	Input FIFO Interrupt Requests	0	0	AINPFIR	AINEFIR	AINFFIR	BINPFIR	BINEFIR	BINFFIR
780D (reserved)										
FIFO A-OUT										
780E	AOUTDATA	Load Output FIFO A	D7	D6	D5	D4	D3	D2	D1	D0
780F	AOUTBC	Output FIFO A Byte Count	0	D6	D5	D4	D3	D2	D1	D0
7810	AOUTPF	FIFO A-OUT Prog. Flag (internal bit)	LTGT	D6	D5	D4	D3	D2	D1	D0
7811	AOUTPFPIN	FIFO A-OUT Programmable Flag (external pin)	LTGT	D6	D5	D4	D3	D2	D1	D0
7812 (reserved)										
FIFO B-OUT										
7813	BOUTDATA	Load Output FIFO B	D7	D6	D5	D4	D3	D2	D1	D0
7814	BOUTBC	Output FIFO B Byte Count	0	D6	D5	D4	D3	D2	D1	D0
7815	BOUTPF	FIFO B-OUT Prog. (internal bit)	LTGT	D6	D5	D4	D3	D2	D1	D0
7816	BOUTPFPIN	FIFO B-OUT Prog. Flag (external pin)	LTGT	D6	D5	D4	D3	D2	D1	D0
7817 (reserved)										
FIFO A/B OUT Control										
7818	ABOUTF	Output FIFOs Toggle control and flags	OUTTOG	OUTSEL	AOUTPF	AOUTEF	AOUTFF	BOUTPF	BOUTEF	BOUTFF
7819	ABOUTIE	Output FIFO Interrupt Enables	0	0	AOUTPFIE	AOUTEFIE	AOUTFFIE	BOUTPFIE	BOUTEFIE	BOUTFFIE
781A	ABOUTIRQ	Output FIFO Interrupt Requests	0	0	AOUTPFIR	AOUTEFIR	AOUTFFIR	BOUTPFIR	BOUTEFIR	BOUTFFIR
781B (reserved)										
FIFO A/B Global Control										
781C	ABSETUP	FIFO Setup	0	0	ASYNC	DBLIN	0	OUTDLY	0	DBLOUT

4.0 Register Summary (continued)

Addr	Name	Description	D7	D6	D5	D4	D3	D2	D1	D0
781D	ABPOLAR	FIFO Control Signals Polarity	0	0	BOE	AOE	SLRD	SLWR	ASEL	BSEL
781E	ABFLUSH	Write (data=x) to reset all flags	*	*	*	*	*	*	*	*
781F-7823 (reserved)										
7824	WFSELECT	Waveform Selector	SINGLEWR		SINGLERD		FIFOWR		FIFORD	
7825	IDLE_CS	GPIF IDLE State control	DONE	0	0	0	0	0	0	IDLEDRV
7826	IDLECTLOUT	GPIF IDLE CTL states	IOE3	IOE2	IOE1/CTL5	IOE0/CTL4	CTL3	CTL2	CTL1	CTL0
7827	CTLOUTCFG	GPIF CTL Drive mode	TRICTL	0	CTL5	CTL4	CTL3	CTL2	CTL1	CTL0
7828-7829 (reserved)										
782A	GPIFADRL	GPIF Address	*	*	ADR5	ADR4	ADR3	ADR2	ADR1	ADR0
782B (reserved)										
782C	AINTC	FIFO A In Transfer Count	FITC	Transfer Count						
782D	AOUTTC	FIFO A Out Transfer Count	FITC	Transfer Count						
782E	ATRIG	Trigger a FIFO A RD/WR	*	*	*	*	*	*	*	*
782F (reserved)										
7830	BINTC	FIFO B In Transfer Count	FITC	Transfer Count						
7831	BOUTTC	FIFO B Out Transfer Count	FITC	Transfer Count						
7832	BTRIG	Trigger a FIFO B RD/WR	*	*	*	*	*	*	*	*
7833 (reserved)										
7834	SGLDATH	GPIF Data High	D15	D14	D13	D12	D11	D10	D9	D8
7835	SGLDATHLTRIG	GPIF Data Low and Trigger	D7	D6	D5	D4	D3	D2	D1	D0
7836	SGLDATHLN-TRIG	GPIF Data Low and No Trigger	D7	D6	D5	D4	D3	D2	D1	D0
7837(reserved)										
7838	READY	GPIF Ready flags	INTRDY	SAS	RDY5	RDY4	RDY3	RDY2	RDY1	RDY0
7839	ABORT	Abort current GPIF cycle	*	*	*	*	*	*	*	*
783A (reserved)										
783B	GENIE	GPIF/DMA Interrupt Enable	0	0	0	0	0	DMADN	GPWR	GPDONE
783C	GENIRQ	GPIF/DMA Interrupt Request	0	0	0	0	0	DMADN	GPWR	GPDONE
783D-7840 (reserved)										
IO Ports D, E										
7841	OUTD	Output Port D	OUTD7	OUTD6	OUTD5	OUTD4	OUTD3	OUTD2	OUTD1	OUTD0
7842	PIND	Input Port D pins	PIND7	PIND6	PIND5	PIND4	PIND3	PIND2	PIND1	PIND0
7843	OED	Port D Output Enable	0ED7	0ED6	0ED5	0ED4	0ED3	0ED2	0ED1	0ED0
7844 (reserved)										
7845	OUTE	Output Port E	OUTE7	OUTE6	OUTE5	OUTE4	OUTE3	OUTE2	OUTE1	OUTE0
7846	PINSE	Input Port E pins	PINE7	PINE6	PINE5	PINE4	PINE3	PINE2	PINE1	PINE0
7847	OEE	Port E Output Enable	OEE7	OEE6	OEE5	OEE4	OEE3	OEE2	OEE1	OEE0
7848 (reserved)										
7849	PORTSETUP	Timer0 Clock source, Port-to-SFR mapping	0	0	0	0	0	0	T0CLK	SFRPORT
784A	IFCONFIG	Select 8/16 bit data bus, configure buses (IF)	52ONE	0	0	0	GSTATE	BUS16	IF1	IF0
784B	PORTACF2	Port A Configuration #2	0	0	SLRD	SLWR	0	0	0	0

4.0 Register Summary (continued)

Addr	Name	Description	D7	D6	D5	D4	D3	D2	D1	D0
784C	PORTCCF2	Port C Configuration #2	CTL5	CTL4	CTL3	CTL1	RDY3	0	RDY1	RDY0
784D-784E (reserved)										
DMA Control										
784F	DMASRCH	DMA Source H	A15	A14	A13	A12	A11	A10	A9	A8
7850	DMASRCL	DMA Source L	A7	A6	A5	A4	A3	A2	A1	A0
7851	DMADESTH	DMA Destination H	A15	A14	A13	A12	A11	A10	A9	A8
7852	DMADESTL	DMA Destination L	A7	A6	A5	A4	A3	A2	A1	A0
7853 (reserved)										
7854	DMALEN	DMA Transfer Length	D7	D6	D5	D4	D3	D2	D1	D0
7855	DMAGO	Start DMA Transfer	DONE	*	*	*	*	*	*	*
7856 (reserved)										
7857	DMABURST	DMA Burst control	*	*	*	DSTR2	DSTR1	DSTR0	RB	WB
7858	DMAEXTFIFO	Dummy data reg for using RAM as external FIFO	n/a	n/a	n/a	n/a	n/a	n/a	n/a	n/a
7859 - 785C (reserved)										
785D	INT4IVEC	Interrupt 4 Vector	0	1	I4V3	I4V2	I4V1	I4V0	0	0
785E	INT4SETUP	Interrupt 4 Set-up	0	0	0	0	0	INT4SFC	INTERNAL	AV4EN
785F-78FF (reserved)										
7900-797F	WFDESC	GPIF Waveform Descriptors								
7980-7B3F (reserved)										
Endpoint 0-7 Data Buffers										
7B40	OUT7BUF	(64 bytes)	d7	d6	d5	d4	d3	d2	d1	d0
7B80	IN7BUF	(64 bytes)	d7	d6	d5	d4	d3	d2	d1	d0
7BC0	OUT6BUF	(64 bytes)	d7	d6	d5	d4	d3	d2	d1	d0
7C00	IN6BUF	(64 bytes)	d7	d6	d5	d4	d3	d2	d1	d0
7C40	OUT5BUF	(64 bytes)	d7	d6	d5	d4	d3	d2	d1	d0
7C80	IN5BUF	(64 bytes)	d7	d6	d5	d4	d3	d2	d1	d0
7CC0	OUT4BUF	(64 bytes)	d7	d6	d5	d4	d3	d2	d1	d0
7D00	IN4BUF	(64 bytes)	d7	d6	d5	d4	d3	d2	d1	d0
7D40	OUT3BUF	(64 bytes)	d7	d6	d5	d4	d3	d2	d1	d0
7D80	IN3BUF	(64 bytes)	d7	d6	d5	d4	d3	d2	d1	d0
7DC0	OUT2BUF	(64 bytes)	d7	d6	d5	d4	d3	d2	d1	d0
7E00	IN2BUF	(64 bytes)	d7	d6	d5	d4	d3	d2	d1	d0
7E40	OUT1BUF	(64 bytes)	d7	d6	d5	d4	d3	d2	d1	d0
7E80	IN1BUF	(64 bytes)	d7	d6	d5	d4	d3	d2	d1	d0
7EC0	OUT0BUF	(64 bytes)	d7	d6	d5	d4	d3	d2	d1	d0
7F00	IN0BUF	(64 bytes)	d7	d6	d5	d4	d3	d2	d1	d0
7F40-7F5F (reserved)										
Isochronous Data										
7F60	OUT8DATA	Endpoint 8 OUT Data	d7	d6	d5	d4	d3	d2	d1	d0
7F61	OUT9DATA	Endpoint 9 OUT Data	d7	d6	d5	d4	d3	d2	d1	d0
7F62	OUT10DATA	Endpoint 10 OUT Data	d7	d6	d5	d4	d3	d2	d1	d0
7F63	OUT11DATA	Endpoint 11 OUT Data	d7	d6	d5	d4	d3	d2	d1	d0
7F64	OUT12DATA	Endpoint 12 OUT Data	d7	d6	d5	d4	d3	d2	d1	d0

4.0 Register Summary (continued)

Addr	Name	Description	D7	D6	D5	D4	D3	D2	D1	D0
7F65	OUT13DATA	Endpoint 13 OUT Data	d7	d6	d5	d4	d3	d2	d1	d0
7F66	OUT14DATA	Endpoint 14 OUT Data	d7	d6	d5	d4	d3	d2	d1	d0
7F67	OUT15DATA	Endpoint 15 OUT Data	d7	d6	d5	d4	d3	d2	d1	d0
7F68	IN8DATA	Endpoint 8 IN Data	d7	d6	d5	d4	d3	d2	d1	d0
7F69	IN9DATA	Endpoint 9 IN Data	d7	d6	d5	d4	d3	d2	d1	d0
7F6A	IN10DATA	Endpoint 10 IN Data	d7	d6	d5	d4	d3	d2	d1	d0
7F6B	IN11DATA	Endpoint 11 IN Data	d7	d6	d5	d4	d3	d2	d1	d0
7F6C	IN12DATA	Endpoint 12 IN Data	d7	d6	d5	d4	d3	d2	d1	d0
7F6D	IN13DATA	Endpoint 13 IN Data	d7	d6	d5	d4	d3	d2	d1	d0
7F6E	IN14DATA	Endpoint 14 IN Data	d7	d6	d5	d4	d3	d2	d1	d0
7F6F	IN15DATA	Endpoint 15 IN Data	d7	d6	d5	d4	d3	d2	d1	d0
	Isochronous Byte Counts									
7F70	OUT8BCH	EP8 Out Byte Count H	0	0	0	0	0	0	d9	d8
7F71	OUT8BCL	EP8 Out Byte Count L	d7	d6	d5	d4	d3	d2	d1	d0
7F72	OUT9BCH	EP9 Out Byte Count H	0	0	0	0	0	0	d9	d8
7F73	OUT9BCL	EP9 Out Byte Count L	d7	d6	d5	d4	d3	d2	d1	d0
7F74	OUT10BCH	EP10 Out Byte Count H	0	0	0	0	0	0	d9	d8
7F75	OUT10BCL	EP10 Out Byte Count L	d7	d6	d5	d4	d3	d2	d1	d0
7F76	OUT11BCH	EP11 Out Byte Count H	0	0	0	0	0	0	d9	d8
7F77	OUT11BCL	EP11 Out Byte Count L	d7	d6	d5	d4	d3	d2	d1	d0
7F78	OUT12BCH	EP12 Out Byte Count H	0	0	0	0	0	0	d9	d8
7F79	OUT12BCL	EP12 Out Byte Count L	d7	d6	d5	d4	d3	d2	d1	d0
7F7A	OUT13BCH	EP13 Out Byte Count H	0	0	0	0	0	0	d9	d8
7F7B	OUT13BCL	EP13 Out Byte Count L	d7	d6	d5	d4	d3	d2	d1	d0
7F7C	OUT14BCH	EP14 Out Byte Count H	0	0	0	0	0	0	d9	d8
7F7D	OUT14BCL	EP14 Out Byte Count L	d7	d6	d5	d4	d3	d2	d1	d0
7F7E	OUT15BCH	EP15 Out Byte Count H	0	0	0	0	0	0	d9	d8
7F7F	OUT15BCL	EP15 Out Byte Count L	d7	d6	d5	d4	d3	d2	d1	d0
7F80-7F91 (reserved)										
	CPU Registers									
7F92	CPUCS	Control & Status	rv3	rv2	rv1	rv0	24/48	CLKINV	CLKOUT OE	8051RES
7F93	PORTACFG	Port A Configuration	RxD1out	RxD0out	FRD	FWR	CS	OE	T1out	T0out
7F94	PORTBCFG	Port B Configuration	T2OUT	INT6	INT5	INT4	TxD1	RxD1	T2EX	T2
7F95	PORTCCFG	Port C Configuration	RD	WR	T1	T0	INT1	INT0	TxD0	RxD0
	Input-Output Port Registers									
7F96	OUTA	Output Register A	OUTA7	OUTA6	OUTA5	OUTA4	OUTA3	OUTA2	OUTA1	OUTA0
7F97	OUTB	Output Register B	OUTB7	OUTB6	OUTB5	OUTB4	OUTB3	OUTB2	OUTB1	OUTB0
7F98	OUTC	Output Register C	OUTC7	OUTC6	OUTC5	OUTC4	OUTC3	OUTC2	OUTC1	OUTC0
7F99	PINSA	Port Pins A	PINA7	PINA6	PINA5	PINA4	PINA3	PINA2	PINA1	PINA0
7F9A	PINSB	Port Pins B	PINB7	PINB6	PINB5	PINB4	PINB3	PINB2	PINB1	PINB0
7F9B	PINSC	Port Pins C	PINC7	PINC6	PINC5	PINC4	PINC3	PINC2	PINC1	PINC0
7F9C	OEA	Output Enable A	OEA7	OEA6	OEA5	OEA4	OEA3	OEA2	OEA1	OEA0
7F9D	OEB	Output Enable B	OEB7	OEB6	OEB5	OEB4	OEB3	OEB2	OEB1	OEB0

4.0 Register Summary (continued)

Addr	Name	Description	D7	D6	D5	D4	D3	D2	D1	D0
7F9E	OEC	Output Enable C	OEC7	OEC6	OEC5	OEC4	OEC3	OEC2	OEC1	OEC0
7F9F	UART230	230k Baud Configuration	0	0	0	0	0	0	UART1	UART0
Isochronous Control/Status Registers										
7FA0	ISOERR	ISO OUT Endpoint Error	ISO15 ERR	ISO14 ERR	ISO13 ERR	ISO12 ERR	ISO11 ERR	ISO10 ERR	ISO9 ERR	ISO8 ERR
7FA1	ISOCTL	Isochronous Control	*	*	*	*	PPSTAT	0	0	ISODISAB
7FA2	ZBCOUT	Zero Byte Count bits	EP15	EP14	EP13	EP12	EP11	EP10	EP9	EP8
7FA3 (reserved)										
7FA4 (reserved)										
I²C Registers										
7FA5	I2CS	Control & Status	START	STOP	LASTRD	ID1	ID0	BERR	ACK	DONE
7FA6	I2DAT	Data	d7	d6	d5	d4	d3	d2	d1	d0
7FA7	I2CMODE	STOP Int Enable, I ² C bus speed	0	0	0	0	0	0	STOPIE	400KHZ
Interrupts										
7FA8	IVEC	Interrupt Vector	0	IV4	IV3	IV2	IV1	IV0	0	0
7FA9	IN07IRQ	EPIN Interrupt Request	IN7IR	IN6IR	IN5IR	IN4IR	IN3IR	IN2IR	IN1IR	IN0IR
7FAA	OUT07IRQ	EPOUT Interrupt Request	OUT7IR	OUT6IR	OUT5IR	OUT4IR	OUT3IR	OUT2IR	OUT1IR	OUT0IR
7FAB	USBIRQ	USB Interrupt Request	0	0	IBNIR	URESIR	SUSPIR	SUTOKIR	SOFIR	SUDAVIR
7FAC	IN07IEN	EP0-7IN Int Enables	IN7IEN	IN6IEN	IN5IEN	IN4IEN	IN3IEN	IN2IEN	IN1IEN	IN0IEN
7FAD	OUT07IEN	EP0-7OUT Int Enables	OUT7IEN	OUT6IEN	OUT5IEN	OUT4IEN	OUT3IEN	OUT2IEN	OUT1IEN	OUT0IEN
7FAE	USBIEN	USB Int Enables	0	0	IBNIE	URESIE	SUSPIE	SUTOKIE	SOFIE	SUDAVIE
7FAF	USBBAV	Breakpoint & Autovector	*	*	*	INT2SFC	BREAK	BPPULSE	BPEN	AVEN
7FB0	IBNID	IN-Bulk-NAK ID	EP7IN	EP6IN	EP5IN	EP4IN	EP3IN	EP2IN	EP1IN	EP0IN
7FB1	IBNMASK	IN-Bulk-NAK Intr. mask	EP7IN	EP6IN	EP5IN	EP4IN	EP3IN	EP2IN	EP1IN	EP0IN
7FB2	BPADDRH	Breakpoint Address H	A15	A14	A13	A12	A11	A10	A9	A8
7FB3	BPADDRL	Breakpoint Address L	A7	A6	A5	A4	A3	A2	A1	A0
Bulk Endpoints 0-7										
7FB4	EP0CS	Control & Status	*	*	*	*	OUTBSY	INBSY	HSNAK	EP0STALL
7FB5	IN0BC	Byte Count	*	d6	d5	d4	d3	d2	d1	d0
7FB6	IN1CS	Control & Status	*	*	*	*	*	*	in1bsy	in1stl
7FB7	IN1BC	Byte Count	*	d6	d5	d4	d3	d2	d1	d0
7FB8	IN2CS	Control & Status	*	*	*	*	*	*	in2bsy	in2stl
7FB9	IN2BC	Byte Count	*	d6	d5	d4	d3	d2	d1	d0
7FBA	IN3CS	Control & Status	*	*	*	*	*	*	in3bsy	in3stl
7FBB	IN3BC	Byte Count	*	d6	d5	d4	d3	d2	d1	d0
7FBC	IN4CS	Control & Status	*	*	*	*	*	*	in4bsy	in4stl
7FBD	IN4BC	Byte Count	*	d6	d5	d4	d3	d2	d1	d0
7FBE	IN5CS	Control & Status	*	*	*	*	*	*	in5bsy	in5stl
7FBF	IN5BC	Byte Count	*	d6	d5	d4	d3	d2	d1	d0
7FC0	IN6CS	Control & Status	*	*	*	*	*	*	in6bsy	in6stl
7FC1	IN6BC	Byte Count	*	d6	d5	d4	d3	d2	d1	d0
7FC2	IN7CS	Control & Status	*	*	*	*	*	*	in7bsy	in7stl
7FC3	IN7BC	Byte Count	*	d6	d5	d4	d3	d2	d1	d0
7FC4 (reserved)										

4.0 Register Summary (continued)

Addr	Name	Description	D7	D6	D5	D4	D3	D2	D1	D0
7FC5	OUT0BC	Byte Count	*	d6	d5	d4	d3	d2	d1	d0
7FC6	OUT1CS	Control & Status	*	*	*	*	*	*	out1bsy	out1stl
7FC7	OUT1BC	Byte Count	*	d6	d5	d4	d3	d2	d1	d0
7FC8	OUT2CS	Control & Status	*	*	*	*	*	*	out2bsy	out2stl
7FC9	OUT2BC	Byte Count	*	d6	d5	d4	d3	d2	d1	d0
7FCA	OUT3CS	Control & Status	*	*	*	*	*	*	out3bsy	out3stl
7FCB	OUT3BC	Byte Count	*	d6	d5	d4	d3	d2	d1	d0
7FCC	OUT4CS	Control & Status	*	*	*	*	*	*	out4bsy	out4stl
7FCD	OUT4BC	Byte Count	*	d6	d5	d4	d3	d2	d1	d0
7FCE	OUT5CS	Control & Status	*	*	*	*	*	*	out5bsy	out5stl
7FCF	OUT5BC	Byte Count	*	d6	d5	d4	d3	d2	d1	d0
7FD0	OUT6CS	Control & Status	*	*	*	*	*	*	out6bsy	out6stl
7FD1	OUT6BC	Byte Count	*	d6	d5	d4	d3	d2	d1	d0
7FD2	OUT7CS	Control & Status	*	*	*	*	*	*	out7bsy	out7stl
7FD3	OUT7BC	Byte Count	*	d6	d5	d4	d3	d2	d1	d0
7FC5	OUT0BC	Byte Count	*	d6	d5	d4	d3	d2	d1	d0
7FC6	OUT1CS	Control & Status	*	*	*	*	*	*	out1bsy	out1stl
Global USB Registers										
7FD4	SUDPTRH	Setup Data Ptr H	A15	A14	A13	A12	A11	A10	A9	A8
7FD5	SUDPTRL	Setup Data Ptr L	A7	A6	A5	A4	A3	A2	A1	A0
7FD6	USBCS	USB Control & Status	WakeSRC	*	*	*	DisCon	DiscOE	ReNum	SIGR-SUME
7FD7	TOGCTL	Toggle Control	Q	S	R	IO	0	EP2	EP1	EP0
7FD8	USBFRAMEL	Frame Number L	FC7	FC6	FC5	FC4	FC3	FC2	FC1	FC0
7FD9	USBFRAMEH	Frame Number H	0	0	0	0	0	FC10	FC9	FC8
7FDA (reserved)										
7FDB	FNADDR	Function Address	0	FA6	FA5	FA4	FA3	FA2	FA1	FA0
7FDC (reserved)										
7FDD	USBPAIR	Endpoint Control	ISOsend0	*	PR6OUT	PR4OUT	PR2OUT	PR6IN	PR4IN	PR2IN
7FDE	IN07VAL	Input Endpoint 0–7 valid	IN7VAL	IN6VAL	IN5VAL	IN4VAL	IN3VAL	IN2VAL	IN1VAL	1
7FDF	OUT07VAL	Output Endpoint 0–7 valid	OUT7VAL	OUT6VAL	OUT5VAL	OUT4VAL	OUT3VAL	OUT2VAL	OUT1VAL	1
7FE0	INISOVAL	Input EP 8–15 valid	IN15VAL	IN14VAL	IN13VAL	IN12VAL	IN11VAL	IN10VAL	IN9VAL	IN8VAL
7FE1	OUTISOVAL	Output EP 8–15 valid	OUT15VAL	OUT14VAL	OUT13VAL	OUT12VAL	OUT11VAL	OUT10VAL	OUT9VAL	OUT8VAL
7FE2	FASTXFR	Fast Transfer Mode	FISO	FBLK	RPOL	RMOD1	RMOD0	WPOL	WMOD1	WMOD0
7FE3	AUTOPTRH	Auto-Pointer H	A15	A14	A13	A12	A11	A10	A9	A8
7FE4	AUTOPTRL	Auto-Pointer L	A7	A6	A5	A4	A3	A2	A1	A0
7FE5	AUTODATA	Auto Pointer Data	D7	D6	D5	D4	D3	D2	D1	D0
7FE6-7FE7 (reserved)										
Setup Data										
7FE8	SETUPDAT	8 bytes of SETUP data	d7	d6	d5	d4	d3	d2	d1	d0
Isochronous FIFO Sizes										
7FF0	OUT8ADDR	Endpt 8 OUT Start Addr	A9	A8	A7	A6	A5	A4	0	0
7FF1	OUT9ADDR	Endpt 9 OUT Start Addr	A9	A8	A7	A6	A5	A4	0	0
7FF2	OUT10ADDR	Endpt 10 OUT Start Addr	A9	A8	A7	A6	A5	A4	0	0