



Chipsmall Limited consists of a professional team with an average of over 10 year of expertise in the distribution of electronic components. Based in Hongkong, we have already established firm and mutual-benefit business relationships with customers from,Europe,America and south Asia,supplying obsolete and hard-to-find components to meet their specific needs.

With the principle of "Quality Parts,Customers Priority,Honest Operation,and Considerate Service",our business mainly focus on the distribution of electronic components. Line cards we deal with include Microchip,ALPS,ROHM,Xilinx,Pulse,ON,Everlight and Freescale. Main products comprise IC,Modules,Potentiometer,IC Socket,Relay,Connector.Our parts cover such applications as commercial,industrial, and automotives areas.

We are looking forward to setting up business relationship with you and hope to provide you with the best service and solution. Let us make a better world for our industry!



Contact us

Tel: +86-755-8981 8866 Fax: +86-755-8427 6832

Email & Skype: info@chipsmall.com Web: www.chipsmall.com

Address: A1208, Overseas Decoration Building, #122 Zhenhua RD., Futian, Shenzhen, China



General Description

PSoC® 3 is a true programmable embedded system-on-chip, integrating configurable analog and digital peripherals, memory, and a microcontroller on a single chip. The PSoC 3 architecture boosts performance through:

- 8051 core plus DMA controller and digital filter processor, at up to 67 MHz
- Ultra low power with industry's widest voltage range
- Programmable digital and analog peripherals enable custom functions
- Flexible routing of any analog or digital peripheral function to any pin

PSoC devices employ a highly configurable system-on-chip architecture for embedded control design. They integrate configurable analog and digital circuits, controlled by an on-chip microcontroller. A single PSoC device can integrate as many as 100 digital and analog peripheral functions, reducing design time, board space, power consumption, and system cost while improving system quality.

Features

- Operating characteristics
 - Voltage range: 1.71 to 5.5 V, up to six power domains
 - Temperature range (ambient) –40 to 85 °C^[1]
 - DC to 67-MHz operation
 - Power modes
 - Active mode 1.2 mA at 6 MHz, and 12 mA at 48 MHz
 - 1-µA sleep mode
 - 200-nA hibernate mode with RAM retention
 - Boost regulator from 0.5-V input up to 5-V output
- Performance
 - 8-bit 8051 CPU, 32 interrupt inputs
 - 24-channel direct memory access (DMA) controller
 - 24-bit 64-tap fixed-point digital filter processor (DFB)
- Memories
 - Up to 64 KB program flash, with cache and security features
 - Up to 8 KB additional flash for error correcting code (ECC)
 - Up to 8 KB RAM
 - Up to 2 KB EEPROM
- Digital peripherals
 - Up to four 16-bit timer, counter, and PWM (TCPWM) blocks
 - I²C, 1 Mbps bus speed
 - USB 2.0 certified Full-Speed (FS) 12 Mbps peripheral interface (TID#40770053) using internal oscillator^[2]
 - Full CAN 2.0b, 16 Rx, 8 Tx buffers
 - 16 to 24 universal digital blocks (UDB), programmable to create any number of functions:
 - 8-, 16-, 24-, and 32-bit timers, counters, and PWMs
 - I²C, UART, SPI, I2S, LIN 2.0 interfaces
 - Cyclic redundancy check (CRC)
 - Pseudo random sequence (PRS) generators
 - Quadrature decoders
 - Gate-level logic functions
- Programmable clocking
 - 3- to 62-MHz internal oscillator, 1% accuracy at 3 MHz
 - 4- to 25-MHz external crystal oscillator
 - Internal PLL clock generation up to 67 MHz
 - Low-power internal oscillator at 1, 33, and 100 kHz
 - 32.768-kHz external watch crystal oscillator
 - 12 clock dividers routable to any peripheral or I/O
- Analog peripherals
 - Configurable 8- to 12-bit delta-sigma ADC
 - Up to four 8-bit DACs
 - Up to four comparators
 - Up to four opamps
 - Up to four programmable analog blocks, to create:
 - Programmable gain amplifier (PGA)
 - Transimpedance amplifier (TIA)
 - Mixer
 - Sample and hold circuit
 - CapSense® support, up to 62 sensors
 - 1.024 V ±0.1% internal voltage reference
- Versatile I/O system
 - 29 to 72 I/O pins – up to 62 general-purpose I/Os (GPIOs)
 - Up to eight performance I/O (SIO) pins
 - 25 mA current sink
 - Programmable input threshold and output high voltages
 - Can act as a general-purpose comparator
 - Hot swap capability and overvoltage tolerance
 - Two USBIO pins that can be used as GPIOs
 - Route any digital or analog peripheral to any GPIO
 - LCD direct drive from any GPIO, up to 46 × 16 segments
 - CapSense support from any GPIO
 - 1.2-V to 5.5-V interface voltages, up to four power domains
- Programming and debug
 - JTAG (4-wire), serial wire debug (SWD) (2-wire), and single wire viewer (SWV) interfaces
 - Bootloader programming through I²C, SPI, UART, USB, and other interfaces
- Package options: 48-pin SSOP, 48-pin QFN, 68-pin QFN, 100-pin TQFP, and 72-pin WLCSP
- Development support with free PSoC Creator™ tool
 - Schematic and firmware design support
 - Over 100 PSoC Components™ integrate multiple ICs and system interfaces into one PSoC. Components are free embedded ICs represented by icons. Drag and drop component icons to design systems in PSoC Creator.
 - Includes free Keil 8051 compiler
 - Supports device programming and debugging

Notes

1. The maximum storage temperature is 150 °C in compliance with JEDEC Standard JESD22-A103, High Temperature Storage Life.
2. This feature on select devices only. See [Ordering Information](#) on page 120 for details.

More Information

Cypress provides a wealth of data at www.cypress.com to help you to select the right PSoC device for your design, and to help you to quickly and effectively integrate the device into your design. For a comprehensive list of resources, see the knowledge base article [KBA86521, How to Design with PSoC 3, PSoC 4, and PSoC 5LP](#). Following is an abbreviated list for PSoC 3:

- Overview: [PSoC Portfolio](#), [PSoC Roadmap](#)
- Product Selectors: [PSoC 1](#), [PSoC 3](#), [PSoC 4](#), [PSoC 5LP](#)
In addition, PSoC Creator includes a device selection tool.
- Application notes: Cypress offers a large number of PSoC application notes and [code examples](#) covering a broad range of topics, from basic to advanced level. Recommended application notes for getting started with PSoC 3 are:
 - [AN54181: Getting Started With PSoC 3](#)
 - [AN61290: Hardware Design Considerations](#)
 - [AN57821: Mixed Signal Circuit Board Layout](#)
 - [AN58304: Pin Selection for Analog Designs](#)
 - [AN81623: Digital Design Best Practices](#)
 - [AN73854: Introduction To Bootloaders](#)
- Development Kits:
 - [CY8CKIT-030](#) is designed for analog performance, for developing high-precision analog, low-power, and low-voltage applications.
 - [CY8CKIT-001](#) provides a common development platform for any one of the PSoC 1, PSoC 3, PSoC 4, or PSoC 5LP families of devices.
 - The [MiniProg3](#) device provides an interface for flash programming and debug.
- Technical Reference Manuals (TRM)
 - [Architecture TRM](#)
 - [Registers TRM](#)
 - [Programming Specification](#)

PSoC Creator

PSoC Creator is a free Windows-based Integrated Design Environment (IDE). It enables concurrent hardware and firmware design of PSoC 3, PSoC 4, and PSoC 5LP based systems. Create designs using classic, familiar schematic capture supported by over 100 pre-verified, production-ready PSoC Components; see the [list of component datasheets](#). With PSoC Creator, you can:

1. Drag and drop component icons to build your hardware system design in the main design workspace
2. Codesign your application firmware with the PSoC hardware, using the PSoC Creator IDE C compiler
3. Configure components using the configuration tools
4. Explore the library of 100+ components
5. Review component datasheets

Figure 1. Multiple-Sensor Example Project in PSoC Creator

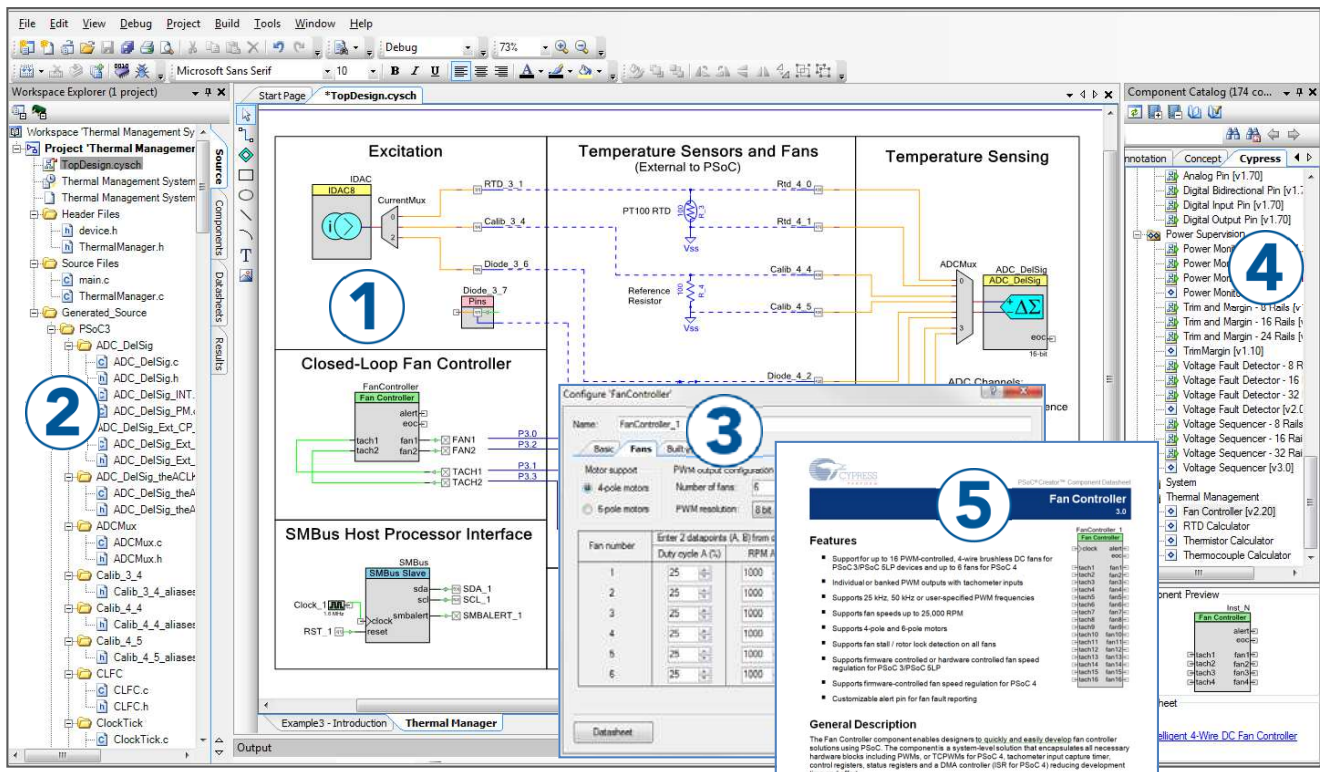

Contents

1. Architectural Overview	4	9. Programming, Debug Interfaces, Resources	65
2. Pinouts	6	9.1 JTAG Interface	66
3. Pin Descriptions	12	9.2 Serial Wire Debug Interface	67
4. CPU	13	9.3 Debug Features	68
4.1 8051 CPU	13	9.4 Trace Features	68
4.2 Addressing Modes	14	9.5 Single Wire Viewer Interface	68
4.3 Instruction Set	14	9.6 Programming Features	68
4.4 DMA and PHUB	18	9.7 Device Security	68
4.5 Interrupt Controller	20	9.8 CSP Package Bootloader	69
5. Memory	23	10. Development Support	70
5.1 Static RAM	23	10.1 Documentation	70
5.2 Flash Program Memory	23	10.2 Online	70
5.3 Flash Security	23	10.3 Tools	70
5.4 EEPROM	24	11. Electrical Specifications	71
5.5 Nonvolatile Latches (NVLs)	24	11.1 Absolute Maximum Ratings	71
5.6 External Memory Interface	25	11.2 Device Level Specifications	72
5.7 Memory Map	26	11.3 Power Regulators	76
6. System Integration	28	11.4 Inputs and Outputs	80
6.1 Clocking System	28	11.5 Analog Peripherals	88
6.2 Power System	31	11.6 Digital Peripherals	105
6.3 Reset	35	11.7 Memory	109
6.4 I/O System and Routing	37	11.8 PSoC System Resources	113
7. Digital Subsystem	44	11.9 Clocking	116
7.1 Example Peripherals	44	12. Ordering Information	120
7.2 Universal Digital Block	46	12.1 Part Numbering Conventions	121
7.3 UDB Array Description	49	13. Packaging	122
7.4 DSI Routing Interface Description	49	14. Acronyms	126
7.5 CAN	51	15. Reference Documents	127
7.6 USB	53	16. Document Conventions	128
7.7 Timers, Counters, and PWMs	53	16.1 Units of Measure	128
7.8 I ² C	54	17. Revision History	129
7.9 Digital Filter Block	56	18. Sales, Solutions, and Legal Information	137
8. Analog Subsystem	56	Worldwide Sales and Design Support.....	137
8.1 Analog Routing	57	Products	137
8.2 Delta-sigma ADC	59	PSoC® Solutions	137
8.3 Comparators	60	Cypress Developer Community.....	137
8.4 Opamps	61	Technical Support	137
8.5 Programmable SC/CT Blocks	61		
8.6 LCD Direct Drive	62		
8.7 CapSense	63		
8.8 Temp Sensor	63		
8.9 DAC	64		
8.10 Up/Down Mixer	64		
8.11 Sample and Hold	65		

1. Architectural Overview

Introducing the CY8C36 family of ultra low-power, flash Programmable System-on-Chip (PSoC[®]) devices, part of a scalable 8-bit PSoC 3 and 32-bit PSoC 5 platform. The CY8C36 family provides configurable blocks of analog, digital, and interconnect circuitry around a CPU subsystem. The combination of a CPU with a flexible analog subsystem, digital subsystem, routing, and I/O enables a high level of integration in a wide variety of consumer, industrial, and medical applications.

Figure 1-1. Simplified Block Diagram

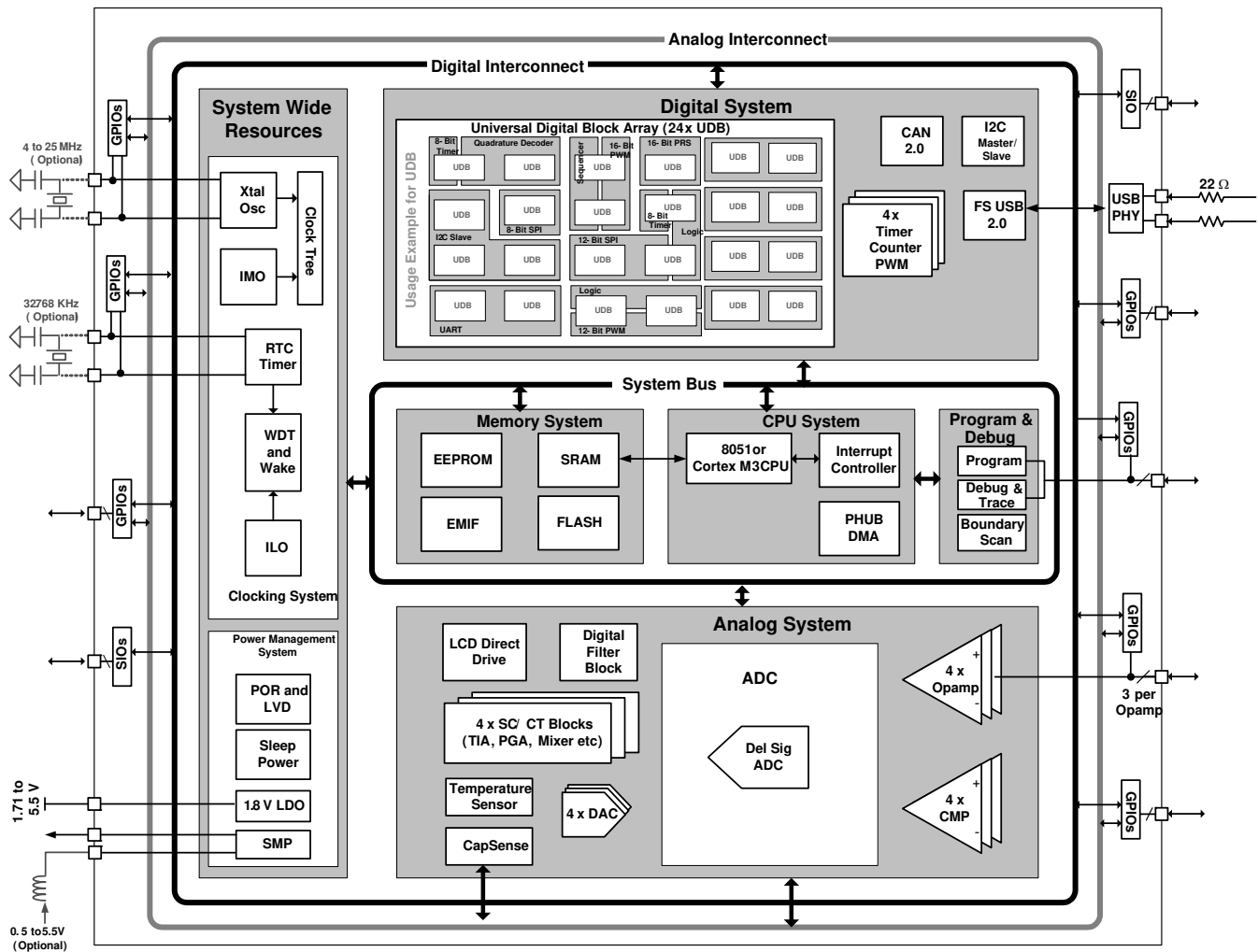

Figure 1-1 illustrates the major components of the CY8C36 family. They are:

- 8051 CPU subsystem
- Nonvolatile subsystem
- Programming, debug, and test subsystem
- Inputs and outputs
- Clocking
- Power
- Digital subsystem
- Analog subsystem

PSoC's digital subsystem provides half of its unique configurability. It connects a digital signal from any peripheral to any pin through the digital system interconnect (DSI). It also provides functional flexibility through an array of small, fast, low-power UDBs. PSoC Creator provides a library of prebuilt and tested standard digital peripherals (UART, SPI, LIN, PRS, CRC, timer, counter, PWM, AND, OR, and so on) that are mapped to the UDB array. You can also easily create a digital circuit using boolean primitives by means of graphical design entry. Each UDB contains programmable array logic (PAL)/programmable logic device (PLD) functionality, together with a small state machine engine to support a wide variety of peripherals.

In addition to the flexibility of the UDB array, PSoC also provides configurable digital blocks targeted at specific functions. For the CY8C36 family these blocks can include four 16-bit timers, counters, and PWM blocks; I²C slave, master, and multi-master; FS USB; and Full CAN 2.0b.

For more details on the peripherals see the “[Example Peripherals](#)” section on page 44 of this data sheet. For information on UDBs, DSI, and other digital blocks, see the “[Digital Subsystem](#)” section on page 44 of this data sheet.

PSoC’s analog subsystem is the second half of its unique configurability. All analog performance is based on a highly accurate absolute voltage reference with less than 0.1-percent error over temperature and voltage. The configurable analog subsystem includes:

- Analog muxes
- Comparators
- Voltage references
- ADC
- DACs
- DFB

All GPIO pins can route analog signals into and out of the device using the internal analog bus. This allows the device to interface up to 62 discrete analog signals. The heart of the analog subsystem is a fast, accurate, configurable delta-sigma ADC with these features:

- Less than 100 μ V offset
- A gain error of 0.2 percent
- INL less than ± 1 LSB
- DNL less than ± 1 LSB
- SINAD better than 66 dB

This converter addresses a wide variety of precision analog applications, including some of the most demanding sensors.

The output of the ADC can optionally feed the programmable DFB through the DMA without CPU intervention. You can configure the DFB to perform IIR and FIR digital filters and several user-defined custom functions. The DFB can implement filters with up to 64 taps. It can perform a 48-bit multiply-accumulate (MAC) operation in one clock cycle.

Four high-speed voltage or current DACs support 8-bit output signals at an update rate of up to 8 Msps. They can be routed out of any GPIO pin. You can create higher resolution voltage PWM DAC outputs using the UDB array. This can be used to create a PWM DAC of up to 10 bits, at up to 48 kHz. The digital DACs in each UDB support PWM, PRS, or delta-sigma algorithms with programmable widths.

In addition to the ADC, DACs, and DFB, the analog subsystem provides multiple:

- Uncommitted opamps
- Configurable switched capacitor/continuous time (SC/CT) blocks. These support:
 - Transimpedance amplifiers
 - Programmable gain amplifiers
 - Mixers
 - Other similar analog components

See the “[Analog Subsystem](#)” section on page 56 of this data sheet for more details.

PSoC’s 8051 CPU subsystem is built around a single-cycle pipelined 8051 8-bit processor running at up to 67 MHz. The CPU subsystem includes a programmable nested vector interrupt controller, DMA controller, and RAM. PSoC’s nested vector interrupt controller provides low latency by allowing the CPU to vector directly to the first address of the interrupt service routine, bypassing the jump instruction required by other architectures. The DMA controller enables peripherals to exchange data without CPU involvement. This allows the CPU to run slower (saving power) or use those CPU cycles to improve the performance of firmware algorithms. The single cycle 8051 CPU runs ten times faster than a standard 8051 processor. The processor speed itself is configurable, allowing you to tune active power consumption for specific applications.

PSoC’s nonvolatile subsystem consists of flash, byte-writable EEPROM, and nonvolatile configuration options. It provides up to 64 KB of on-chip flash. The CPU can reprogram individual blocks of flash, enabling bootloaders. You can enable an ECC for high reliability applications. A powerful and flexible protection model secures the user’s sensitive information, allowing selective memory block locking for read and write protection. Up to 2 KB of byte-writable EEPROM is available on-chip to store application data. Additionally, selected configuration options such as boot speed and pin drive mode are stored in nonvolatile memory. This allows settings to activate immediately after POR.

The three types of PSoC I/O are extremely flexible. All I/Os have many drive modes that are set at POR. PSoC also provides up to four I/O voltage domains through the VDDIO pins. Every GPIO has analog I/O, LCD drive^[3], CapSense^[4], flexible interrupt generation, slew rate control, and digital I/O capability. The SIOs on PSoC allow V_{OH} to be set independently of V_{DDIO} when used as outputs. When SIOs are in input mode they are high impedance. This is true even when the device is not powered or when the pin voltage goes above the supply voltage. This makes the SIO ideally suited for use on an I²C bus where the PSoC may not be powered when other devices on the bus are. The SIO pins also have high current sink capability for applications such as LED drives. The programmable input threshold feature of the SIO can be used to make the SIO function as a general purpose analog comparator. For devices with FS USB the USB physical interface is also provided (USBIO). When not using USB these pins may also be used for limited digital functionality and device programming. All of the features of the PSoC I/Os are covered in detail in the “[I/O System and Routing](#)” section on page 37 of this data sheet.

The PSoC device incorporates flexible internal clock generators, designed for high stability and factory trimmed for high accuracy. The internal main oscillator (IMO) is the clock base for the system, and has 1-percent accuracy at 3 MHz. The IMO can be configured to run from 3 MHz up to 62 MHz. Multiple clock derivatives can be generated from the main clock frequency to meet application needs. The device provides a PLL to generate clock frequencies up to 67 MHz from the IMO, external crystal, or external reference clock. It also contains a separate, very low-power internal low speed oscillator (ILO) for the sleep and watchdog timers. A 32.768-kHz external watch crystal is also supported for use in RTC applications. The clocks, together with programmable clock dividers, provide the flexibility to integrate most timing requirements.

The CY8C36 family supports a wide supply operating range from 1.71 to 5.5 V. This allows operation from regulated supplies such as 1.8 ± 5%, 2.5 V ± 10%, 3.3 V ± 10%, or 5.0 V ± 10%, or directly from a wide range of battery types. In addition, it provides an integrated high efficiency synchronous boost converter that can power the device from supply voltages as low as 0.5 V. This enables the device to be powered directly from a single battery or solar cell. In addition, you can use the boost converter to generate other voltages required by the device, such as a 3.3-V supply for LCD glass drive. The boost's output is available on the V_{BOOST} pin, allowing other devices in the application to be powered from the PSoC.

PSoC supports a wide range of low-power modes. These include a 200-nA hibernate mode with RAM retention and a 1-μA sleep mode with RTC. In the second mode the optional 32.768-kHz watch crystal runs continuously and maintains an accurate RTC.

Power to all major functional blocks, including the programmable digital and analog peripherals, can be controlled independently by firmware. This allows low-power background processing when some peripherals are not in use. This, in turn, provides a total device current of only 1.2 mA when the CPU is running at 6 MHz, or 0.8 mA running at 3 MHz.

The details of the PSoC power modes are covered in the “Power System” section on page 31 of this data sheet. PSoC uses JTAG (4-wire) or SWD (2-wire) interfaces for programming, debug, and test. The 1-wire SWV may also be used for ‘printf’ style debugging. By combining SWD and SWV, you can implement a full debugging interface with just three pins. Using these standard interfaces enables you to debug or program the PSoC with a variety of hardware solutions from Cypress or third party vendors. PSoC supports on-chip break points and 4-KB instruction and data trace memory for debug. Details of the programming, test, and debugging interfaces are discussed in the “Programming, Debug Interfaces, Resources” section on page 65 of this data sheet.

2. Pinouts

Each VDDIO pin powers a specific set of I/O pins. (The USBIOs are powered from VDDD.) Using the VDDIO pins, a single PSoC can support multiple voltage levels, reducing the need for off-chip level shifters. The black lines drawn on the pinout diagrams in Figure 2-3 through Figure 2-6, as well as Table 2-1, show the pins that are powered by each VDDIO.

Each VDDIO may source up to 100 mA total to its associated I/O pins, as shown in Figure 2-1.

Figure 2-1. VDDIO Current Limit

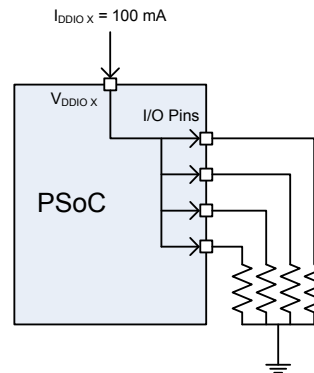

Conversely, for the 100-pin and 68-pin devices, the set of I/O pins associated with any VDDIO may sink up to 100 mA total, as shown in Figure 2-2.

Figure 2-2. I/O Pins Current Limit

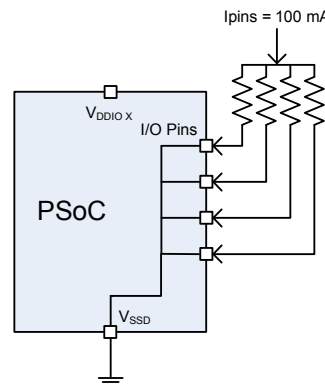

For the 48-pin devices, the set of I/O pins associated with VDDIO0 plus VDDIO2 may sink up to 100 mA total. The set of I/O pins associated with VDDIO1 plus VDDIO3 may sink up to a total of 100 mA.

Notes

3. This feature on select devices only. See [Ordering Information](#) on page 120 for details.
4. GPIOs with opamp outputs are not recommended for use with CapSense.

Figure 2-3. 48-pin SSOP Part Pinout

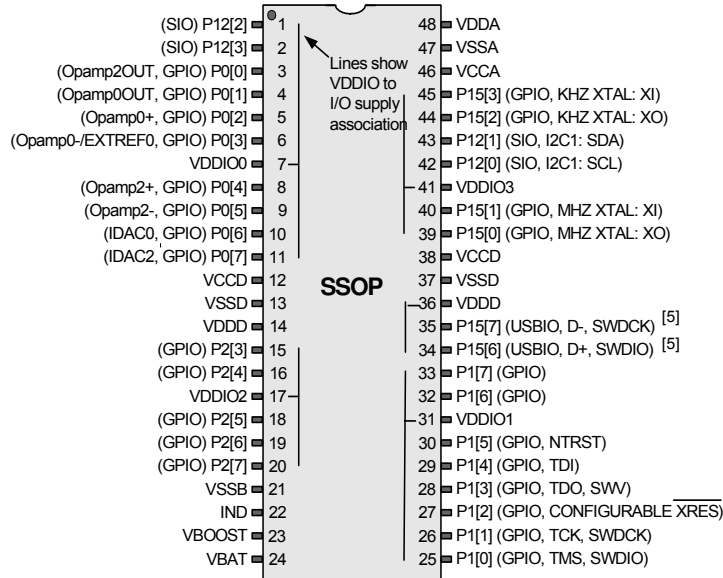
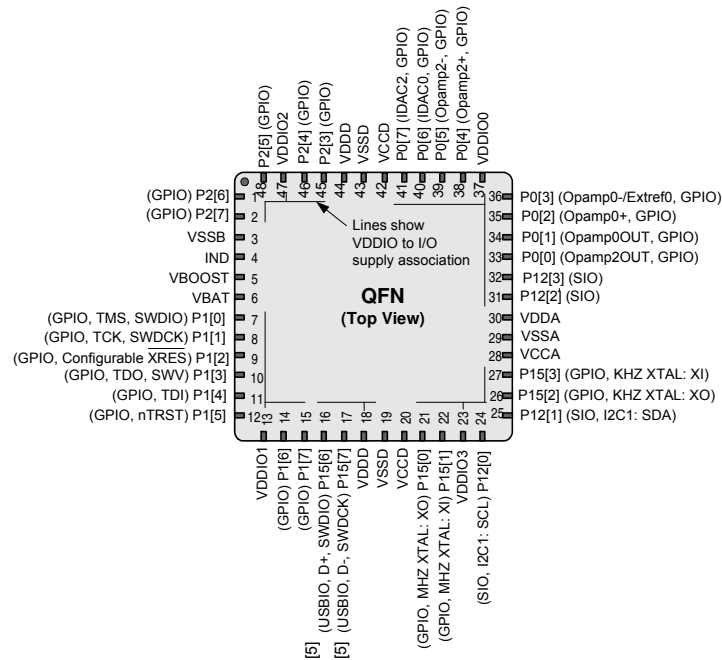

Figure 2-4. 48-pin QFN Part Pinout^[6]



Notes

- Pins are Do Not Use (DNU) on devices without USB. The pin must be left floating.
- The center pad on the QFN package should be connected to digital ground (VSSD) for best mechanical, thermal, and electrical performance. If not connected to ground, it should be electrically floated and not connected to any other signal. For more information, see [AN72845](#), Design Guidelines for QFN Devices.

Figure 2-5. 68-pin QFN Part Pinout^[9]

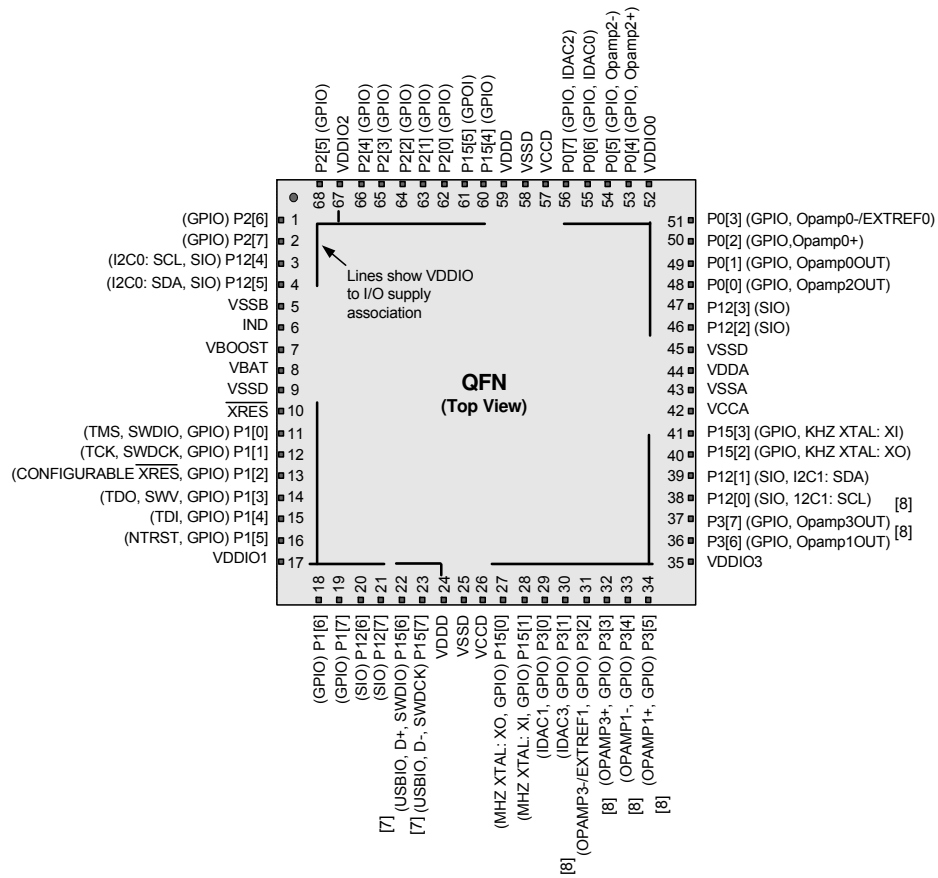

Notes

7. Pins are Do Not Use (DNU) on devices without USB. The pin must be left floating.
8. This feature on select devices only. See [Ordering Information](#) on page 120 for details.
9. The center pad on the QFN package should be connected to digital ground (VSSD) for best mechanical, thermal, and electrical performance. If not connected to ground, it should be electrically floated and not connected to any other signal. For more information, see [AN72845, Design Guidelines for QFN Devices](#).

Table 2-2 shows the pinout for the 72-pin CSP package. Since there are four V_{DDIO} pins, the set of I/O pins associated with any V_{DDIO} may sink up to 100 mA total, same as for the 100-pin and 68-pin devices.

Table 2-2. CSP Pinout

Ball	Name	Ball	Name	Ball	Name
G6	P2[5]	F1	VDDD	A5	VDDA
E5	P2[6]	E1	VSSD	A6	VSSD
F5	P2[7]	E2	VCCD	B6	P12[2]
J7	P12[4]	C1	P15[0]	C6	P12[3]
H6	P12[5]	C2	P15[1]	A7	P0[0]
J6	VSSB	D2	P3[0]	B7	P0[1]
J5	Ind	D3	P3[1]	B5	P0[2]
H5	VBOOST	D4	P3[2]	C5	P0[3]
J4	VBAT	D5	P3[3]	A8	VIO0
H4	VSSD	B4	P3[4]	D6	P0[4]
J3	XRES_N	B3	P3[5]	D7	P0[5]
H3	P1[0]	A1	VIO3	C7	P0[6]
G3	P1[1]	B2	P3[6]	C8	P0[7]
H2	P1[2]	A2	P3[7]	E8	VCCD
J2	P1[3]	C3	P12[0]	F8	VSSD
G4	P1[4]	C4	P12[1]	G8	VDDD
G5	P1[5]	E3	P15[2]	E7	P15[4]
J1	VIO1	E4	P15[3]	F7	P15[5]
F4	P1[6]	B1 ^[12]	NC	G7	P2[0]
F3	P1[7]	B8 ^[12]	NC	H7	P2[1]
H1	P12[6]	D1 ^[12]	NC	H8	P2[2]
G1	P12[7]	D8 ^[12]	NC	F6	P2[3]
G2	P15[6]	A3	VCCA	E6	P2[4]
F2	P15[7]	A4	VSSA	J8	VIO2

Figure 2-7 and Figure 2-8 on page 12 show an example schematic and an example PCB layout, for the 100-pin TQFP part, for optimal analog performance on a two-layer board.

- The two pins labeled VDDD must be connected together.
- The two pins labeled Vccd must be connected together, with capacitance added, as shown in Figure 2-7 and Power System on page 31. The trace between the two Vccd pins should be as short as possible.
- The two pins labeled VSSD must be connected together.

For information on circuit board layout issues for mixed signals, refer to the application note [AN57821 - Mixed Signal Circuit Board Layout Considerations for PSoC® 3 and PSoC 5](#).

Notes

12. Pins are Do Not Use (DNU) on devices without USB. The pin must be left floating.
13. This feature on select devices only. See [Ordering Information](#) on page 120 for details.

Figure 2-7. Example Schematic for 100-pin TQFP Part With Power Connections

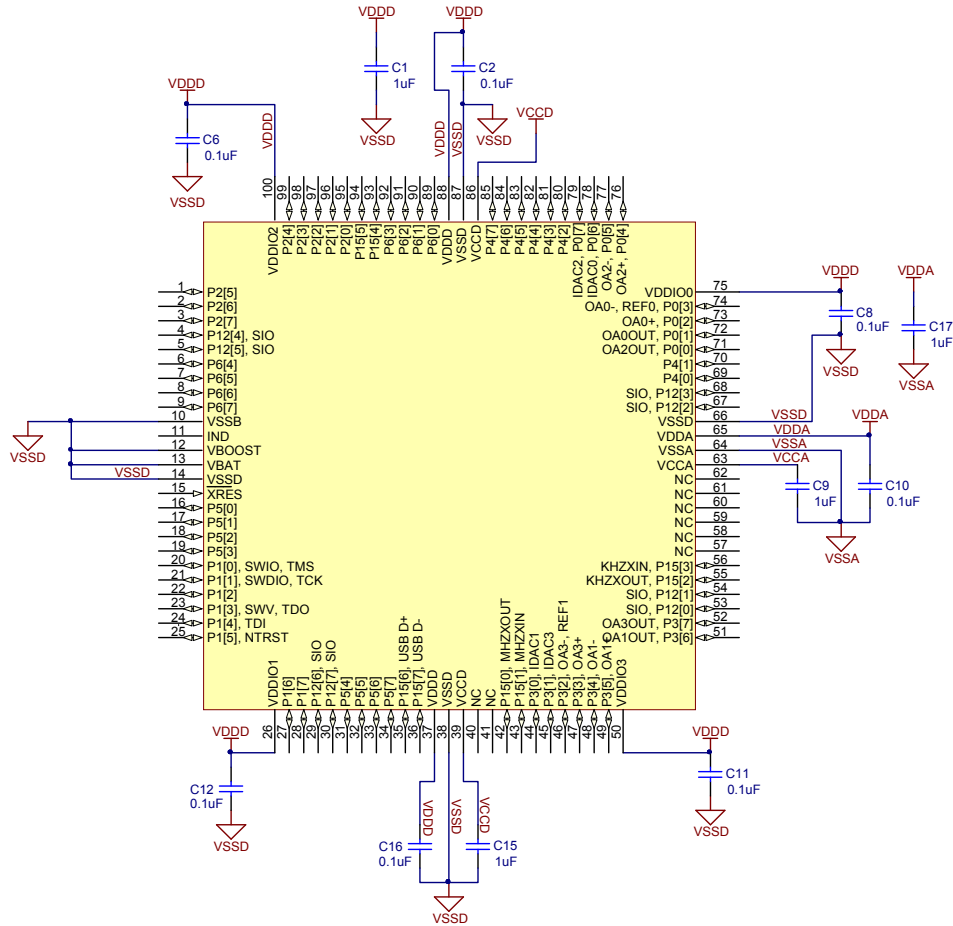

Note The two Vccd pins must be connected together with as short a trace as possible. A trace under the device is recommended, as shown in Figure 2-8 on page 12.

For more information on pad layout, refer to <http://www.cypress.com/cad-resources/psoc-3-cad-libraries>.

Figure 2-8. Example PCB Layout for 100-pin TQFP Part for Optimal Analog Performance

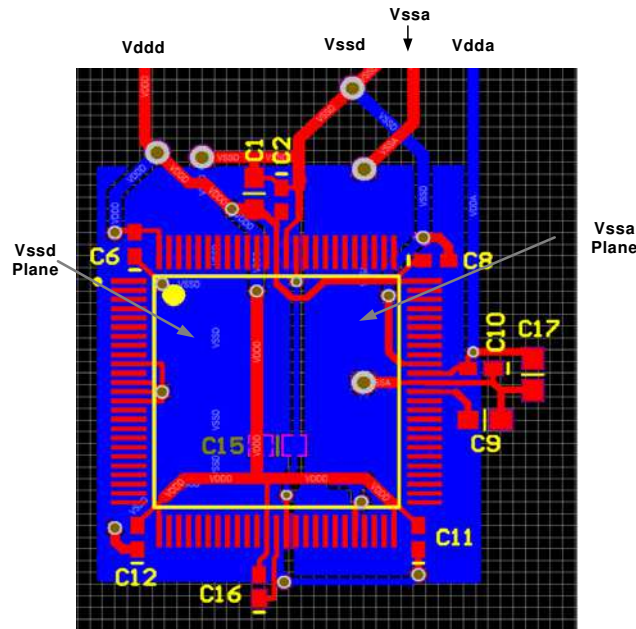

3. Pin Descriptions

IDAC0, IDAC1, IDAC2, IDAC3. Low resistance output pin for high current DACs (IDAC).

Opamp0out, Opamp1out^[15], Opamp2out, Opamp3out^[15].
High current output of uncommitted opamp.^[14]

Extref0, Extref1. External reference input to the analog system.

Opamp0-, Opamp1-^[15], Opamp2-, Opamp3-^[15]. Inverting input to uncommitted opamp.

Opamp0+, Opamp1+^[15], Opamp2+, Opamp3+^[15].
Noninverting input to uncommitted opamp.

GPIO. General purpose I/O pin provides interfaces to the CPU, digital peripherals, analog peripherals, interrupts, LCD segment drive, and CapSense.^[14]

I2C0: SCL, I2C1: SCL. I²C SCL line providing wake from sleep on an address match. Any I/O pin can be used for I²C SCL if wake from sleep is not required.

I2C0: SDA, I2C1: SDA. I²C SDA line providing wake from sleep on an address match. Any I/O pin can be used for I²C SDA if wake from sleep is not required.

Ind. Inductor connection to boost pump.

kHz XTAL: Xo, kHz XTAL: Xi. 32.768 kHz crystal oscillator pin.

MHz XTAL: Xo, MHz XTAL: Xi. 4 to 25 MHz crystal oscillator pin.

nTRST. Optional JTAG Test Reset programming and debug port connection to reset the JTAG connection.

SIO. Special I/O provides interfaces to the CPU, digital peripherals and interrupts with a programmable high threshold voltage, analog comparator, high sink current, and high impedance state when the device is unpowered.

SWDCK. Serial wire debug clock programming and debug port connection.

SWDIO. Serial wire debug input and output programming and debug port connection.

SWV. Single wire viewer debug output.

TCK. JTAG test clock programming and debug port connection.

TDI. JTAG test data in programming and debug port connection.

TDO. JTAG test data out programming and debug port connection.

TMS. JTAG test mode select programming and debug port connection.

USBIO, D+. Provides D+ connection directly to a USB 2.0 bus. May be used as a digital I/O pin. Pins are Do Not Use (DNU) on devices without USB.

USBIO, D-. Provides D- connection directly to a USB 2.0 bus. May be used as a digital I/O pin. Pins are Do Not Use (DNU) on devices without USB.

VBOOST. Power sense connection to boost pump.

VBAT. Battery supply to boost pump.

Notes

14. GPIOs with opamp outputs are not recommended for use with CapSense.

15. This feature on select devices only. See [Ordering Information](#) on page 120 for details.

VCCA. Output of the analog core regulator or the input to the analog core. Requires a 1uF capacitor to VSSA. The regulator output is not designed to drive external circuits. **Note that if you use the device with an external core regulator (externally regulated mode), the voltage applied to this pin must not exceed the allowable range of 1.71 V to 1.89 V.** When using the internal core regulator, (internally regulated mode, the default), do not tie any power to this pin. For details see [Power System](#) on page 31.

VCCD. Output of the digital core regulator or the input to the digital core. The two VCCD pins must be shorted together, with the trace between them as short as possible, and a 1uF capacitor to VSSD. The regulator output is not designed to drive external circuits. **Note that if you use the device with an external core regulator (externally regulated mode), the voltage applied to this pin must not exceed the allowable range of 1.71 V to 1.89 V.** When using the internal core regulator (internally regulated mode, the default), do not tie any power to this pin. For details see [Power System](#) on page 31.

VDDA. Supply for all analog peripherals and analog core regulator. **VDDA must be the highest voltage present on the device. All other supply pins must be less than or equal to VDDA.**

VDDD. Supply for all digital peripherals and digital core regulator. VDDD must be less than or equal to VDDA.

VSSA. Ground for all analog peripherals.

VSSB. Ground connection for boost pump.

VSSD. Ground for all digital logic and I/O pins.

VDDIO0, VDDIO1, VDDIO2, VDDIO3. Supply for I/O pins. See pinouts for specific I/O pin to VDDIO mapping. Each VDDIO must be tied to a valid operating voltage (1.71 V to 5.5 V), and must be less than or equal to VDDA.

XRES (and configurable XRES). External reset pin. Active low with internal pull-up. Pin P1[2] may be configured to be a XRES pin; see [“Nonvolatile Latches \(NVLs\)”](#) on page 24.

4. CPU

4.1 8051 CPU

The CY8C36 devices use a single cycle 8051 CPU, which is fully compatible with the original MCS-51 instruction set. The CY8C36 family uses a pipelined RISC architecture, which executes most instructions in 1 to 2 cycles to provide peak performance of up to 33 MIPS with an average of 2 cycles per instruction. The single cycle 8051 CPU runs ten times faster than a standard 8051 processor.

The 8051 CPU subsystem includes these features:

- Single cycle 8051 CPU
- Up to 64 KB of flash memory, up to 2 KB of EEPROM, and up to 8 KB of SRAM
- 512-byte instruction cache between CPU and flash
- Programmable nested vector interrupt controller
- DMA controller
- Peripheral HUB (PHUB)
- External memory interface (EMIF)

4.2 Addressing Modes

The following addressing modes are supported by the 8051:

- **Direct addressing:** The operand is specified by a direct 8-bit address field. Only the internal RAM and the SFRs can be accessed using this mode.
- **Indirect addressing:** The instruction specifies the register which contains the address of the operand. The registers R0 or R1 are used to specify the 8-bit address, while the data pointer (DPTR) register is used to specify the 16-bit address.
- **Register addressing:** Certain instructions access one of the registers (R0 to R7) in the specified register bank. These instructions are more efficient because there is no need for an address field.
- **Register specific instructions:** Some instructions are specific to certain registers. For example, some instructions always act on the accumulator. In this case, there is no need to specify the operand.
- **Immediate constants:** Some instructions carry the value of the constants directly instead of an address.
- **Indexed addressing:** This type of addressing can be used only for a read of the program memory. This mode uses the Data Pointer as the base and the accumulator value as an offset to read a program memory.
- **Bit addressing:** In this mode, the operand is one of 256 bits.

4.3 Instruction Set

The 8051 instruction set is highly optimized for 8-bit handling and Boolean operations. The types of instructions supported include:

- Arithmetic instructions
- Logical instructions
- Data transfer instructions
- Boolean instructions
- Program branching instructions

4.3.1 Instruction Set Summary

4.3.1.1 Arithmetic Instructions

Arithmetic instructions support the direct, indirect, register, immediate constant, and register-specific instructions. Arithmetic modes are used for addition, subtraction, multiplication, division, increment, and decrement operations. [Table 4-1](#) on page 15 lists the different arithmetic instructions.

Table 4-1. Arithmetic Instructions

Mnemonic	Description	Bytes	Cycles
ADD A,Rn	Add register to accumulator	1	1
ADD A,Direct	Add direct byte to accumulator	2	2
ADD A,@Ri	Add indirect RAM to accumulator	1	2
ADD A,#data	Add immediate data to accumulator	2	2
ADDC A,Rn	Add register to accumulator with carry	1	1
ADDC A,Direct	Add direct byte to accumulator with carry	2	2
ADDC A,@Ri	Add indirect RAM to accumulator with carry	1	2
ADDC A,#data	Add immediate data to accumulator with carry	2	2
SUBB A,Rn	Subtract register from accumulator with borrow	1	1
SUBB A,Direct	Subtract direct byte from accumulator with borrow	2	2
SUBB A,@Ri	Subtract indirect RAM from accumulator with borrow	1	2
SUBB A,#data	Subtract immediate data from accumulator with borrow	2	2
INC A	Increment accumulator	1	1
INC Rn	Increment register	1	2
INC Direct	Increment direct byte	2	3
INC @Ri	Increment indirect RAM	1	3
DEC A	Decrement accumulator	1	1
DEC Rn	Decrement register	1	2
DEC Direct	Decrement direct byte	2	3
DEC @Ri	Decrement indirect RAM	1	3
INC DPTR	Increment data pointer	1	1
MUL	Multiply accumulator and B	1	2
DIV	Divide accumulator by B	1	6
DAA	Decimal adjust accumulator	1	3

4.3.1.2 Logical Instructions

The logical instructions perform Boolean operations such as AND, OR, XOR on bytes, rotate of accumulator contents, and swap of nibbles in an accumulator. The Boolean operations on the bytes are performed on the bit-by-bit basis. [Table 4-2](#) on page 15 shows the list of logical instructions and their description.

Table 4-2. Logical Instructions

Mnemonic	Description	Bytes	Cycles
ANL A,Rn	AND register to accumulator	1	1
ANL A,Direct	AND direct byte to accumulator	2	2
ANL A,@Ri	AND indirect RAM to accumulator	1	2
ANL A,#data	AND immediate data to accumulator	2	2
ANL Direct, A	AND accumulator to direct byte	2	3
ANL Direct, #data	AND immediate data to direct byte	3	3
ORL A,Rn	OR register to accumulator	1	1
ORL A,Direct	OR direct byte to accumulator	2	2
ORL A,@Ri	OR indirect RAM to accumulator	1	2

Table 4-2. Logical Instructions (continued)

Mnemonic	Description	Bytes	Cycles
ORL A,#data	OR immediate data to accumulator	2	2
ORL Direct, A	OR accumulator to direct byte	2	3
ORL Direct, #data	OR immediate data to direct byte	3	3
XRL A,Rn	XOR register to accumulator	1	1
XRL A,Direct	XOR direct byte to accumulator	2	2
XRL A,@Ri	XOR indirect RAM to accumulator	1	2
XRL A,#data	XOR immediate data to accumulator	2	2
XRL Direct, A	XOR accumulator to direct byte	2	3
XRL Direct, #data	XOR immediate data to direct byte	3	3
CLR A	Clear accumulator	1	1
CPL A	Complement accumulator	1	1
RL A	Rotate accumulator left	1	1
RLC A	Rotate accumulator left through carry	1	1
RR A	Rotate accumulator right	1	1
RRC A	Rotate accumulator right though carry	1	1
SWAP A	Swap nibbles within accumulator	1	1

4.3.1.3 Data Transfer Instructions

The data transfer instructions are of three types: the core RAM, xdata RAM, and the lookup tables. The core RAM transfer includes transfer between any two core RAM locations or SFRs. These instructions can use direct, indirect, register, and immediate addressing. The xdata RAM transfer includes only the transfer between the accumulator and the xdata RAM location. It can use only indirect addressing. The lookup tables involve nothing but the read of program memory using the Indexed addressing mode. [Table 4-3](#) lists the various data transfer instructions available.

4.3.1.4 Boolean Instructions

The 8051 core has a separate bit-addressable memory location. It has 128 bits of bit addressable RAM and a set of SFRs that are bit addressable. The instruction set includes the whole menu of bit operations such as move, set, clear, toggle, OR, and AND instructions and the conditional jump instructions. [Table 4-4](#) on page 17 lists the available Boolean instructions.

Table 4-3. Data Transfer Instructions

Mnemonic	Description	Bytes	Cycles
MOV A,Rn	Move register to accumulator	1	1
MOV A,Direct	Move direct byte to accumulator	2	2
MOV A,@Ri	Move indirect RAM to accumulator	1	2
MOV A,#data	Move immediate data to accumulator	2	2
MOV Rn,A	Move accumulator to register	1	1
MOV Rn,Direct	Move direct byte to register	2	3
MOV Rn, #data	Move immediate data to register	2	2
MOV Direct, A	Move accumulator to direct byte	2	2
MOV Direct, Rn	Move register to direct byte	2	2
MOV Direct, Direct	Move direct byte to direct byte	3	3
MOV Direct, @Ri	Move indirect RAM to direct byte	2	3
MOV Direct, #data	Move immediate data to direct byte	3	3
MOV @Ri, A	Move accumulator to indirect RAM	1	2

Table 4-3. Data Transfer Instructions (continued)

Mnemonic	Description	Bytes	Cycles
MOV @Ri, Direct	Move direct byte to indirect RAM	2	3
MOV @Ri, #data	Move immediate data to indirect RAM	2	2
MOV DPTR, #data16	Load data pointer with 16 bit constant	3	3
MOVC A, @A+DPTR	Move code byte relative to DPTR to accumulator	1	5
MOVC A, @A + PC	Move code byte relative to PC to accumulator	1	4
MOVX A,@Ri	Move external RAM (8-bit) to accumulator	1	4
MOVX A, @DPTR	Move external RAM (16-bit) to accumulator	1	3
MOVX @Ri, A	Move accumulator to external RAM (8-bit)	1	5
MOVX @DPTR, A	Move accumulator to external RAM (16-bit)	1	4
PUSH Direct	Push direct byte onto stack	2	3
POP Direct	Pop direct byte from stack	2	2
XCH A, Rn	Exchange register with accumulator	1	2
XCH A, Direct	Exchange direct byte with accumulator	2	3
XCH A, @Ri	Exchange indirect RAM with accumulator	1	3
XCHD A, @Ri	Exchange low order indirect digit RAM with accumulator	1	3

Table 4-4. Boolean Instructions

Mnemonic	Description	Bytes	Cycles
CLR C	Clear carry	1	1
CLR bit	Clear direct bit	2	3
SETB C	Set carry	1	1
SETB bit	Set direct bit	2	3
CPL C	Complement carry	1	1
CPL bit	Complement direct bit	2	3
ANL C, bit	AND direct bit to carry	2	2
ANL C, /bit	AND complement of direct bit to carry	2	2
ORL C, bit	OR direct bit to carry	2	2
ORL C, /bit	OR complement of direct bit to carry	2	2
MOV C, bit	Move direct bit to carry	2	2
MOV bit, C	Move carry to direct bit	2	3
JC rel	Jump if carry is set	2	3
JNC rel	Jump if no carry is set	2	3
JB bit, rel	Jump if direct bit is set	3	5
JNB bit, rel	Jump if direct bit is not set	3	5
JBC bit, rel	Jump if direct bit is set and clear bit	3	5

4.3.1.5 Program Branching Instructions

The 8051 supports a set of conditional and unconditional jump instructions that help to modify the program execution flow. Table 4-5 shows the list of jump instructions.

Table 4-5. Jump Instructions

Mnemonic	Description	Bytes	Cycles
ACALL addr11	Absolute subroutine call	2	4
LCALL addr16	Long subroutine call	3	4
RET	Return from subroutine	1	4
RETI	Return from interrupt	1	4
AJMP addr11	Absolute jump	2	3
LJMP addr16	Long jump	3	4
SJMP rel	Short jump (relative address)	2	3
JMP @A + DPTR	Jump indirect relative to DPTR	1	5
JZ rel	Jump if accumulator is zero	2	4
JNZ rel	Jump if accumulator is nonzero	2	4
CJNE A, Direct, rel	Compare direct byte to accumulator and jump if not equal	3	5
CJNE A, #data, rel	Compare immediate data to accumulator and jump if not equal	3	4
CJNE Rn, #data, rel	Compare immediate data to register and jump if not equal	3	4
CJNE @Ri, #data, rel	Compare immediate data to indirect RAM and jump if not equal	3	5
DJNZ Rn, rel	Decrement register and jump if not zero	2	4
DJNZ Direct, rel	Decrement direct byte and jump if not zero	3	5
NOP	No operation	1	1

4.4 DMA and PHUB

The PHUB and the DMA controller are responsible for data transfer between the CPU and peripherals, and also data transfers between peripherals. The PHUB and DMA also control device configuration during boot. The PHUB consists of:

- A central hub that includes the DMA controller, arbiter, and router
- Multiple spokes that radiate outward from the hub to most peripherals

There are two PHUB masters: the CPU and the DMA controller. Both masters may initiate transactions on the bus. The DMA channels can handle peripheral communication without CPU intervention. The arbiter in the central hub determines which DMA channel is the highest priority if there are multiple requests.

4.4.1 PHUB Features

- CPU and DMA controller are both bus masters to the PHUB
- Eight Multi-layer AHB Bus parallel access paths (spokes) for peripheral access

- Simultaneous CPU and DMA access to peripherals located on different spokes
- Simultaneous DMA source and destination burst transactions on different spokes
- Supports 8-, 16-, 24-, and 32-bit addressing and data

Table 4-6. PHUB Spokes and Peripherals

PHUB Spokes	Peripherals
0	SRAM
1	IOs, PICU, EMIF
2	PHUB local configuration, Power manager, Clocks, IC, SWV, EEPROM, Flash programming interface
3	Analog interface and trim, Decimator
4	USB, CAN, I ² C, Timers, Counters, and PWMs
5	DFB
6	UDBs group 1
7	UDBs group 2

4.4.2 DMA Features

- 24 DMA channels
- Each channel has one or more transaction descriptors (TD) to configure channel behavior. Up to 128 total TDs can be defined
- TDs can be dynamically updated
- Eight levels of priority per channel
- Any digitally routable signal, the CPU, or another DMA channel, can trigger a transaction
- Each channel can generate up to two interrupts per transfer
- Transactions can be stalled or canceled
- Supports transaction size of infinite or 1 to 64 KB
- TDs may be nested and/or chained for complex transactions

4.4.3 Priority Levels

The CPU always has higher priority than the DMA controller when their accesses require the same bus resources. Due to the system architecture, the CPU can never starve the DMA. DMA channels of higher priority (lower priority number) may interrupt current DMA transfers. In the case of an interrupt, the current transfer is allowed to complete its current transaction. To ensure latency limits when multiple DMA accesses are requested simultaneously, a fairness algorithm guarantees an interleaved minimum percentage of bus bandwidth for priority levels 2 through 7. Priority levels 0 and 1 do not take part in the fairness algorithm and may use 100% of the bus bandwidth. If a tie occurs on two DMA requests of the same priority level, a simple round robin method is used to evenly share the allocated bandwidth. The round robin allocation can be disabled for each DMA channel, allowing it to always be at the head of the line. Priority levels 2 to 7 are guaranteed the minimum bus bandwidth shown in [Table 4-7](#) after the CPU and DMA priority levels 0 and 1 have satisfied their requirements.

Table 4-7. Priority Levels

Priority Level	% Bus Bandwidth
0	100.0
1	100.0
2	50.0
3	25.0
4	12.5
5	6.2
6	3.1
7	1.5

When the fairness algorithm is disabled, DMA access is granted based solely on the priority level; no bus bandwidth guarantees are made.

4.4.4 Transaction Modes Supported

The flexible configuration of each DMA channel and the ability to chain multiple channels allow the creation of both simple and complex use cases. General use cases include, but are not limited to:

4.4.4.1 Simple DMA

In a simple DMA case, a single TD transfers data between a source and sink (peripherals or memory location). The basic timing diagrams of DMA read and write cycles shown in [Figure 4-1](#). For more description on other transfer modes, refer to the Technical Reference Manual.

Figure 4-1. DMA Timing Diagram

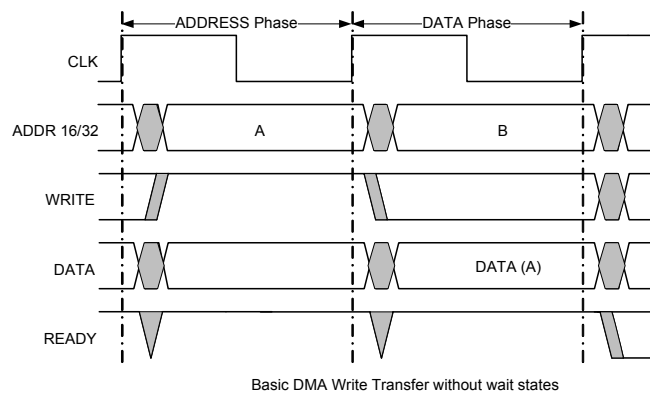
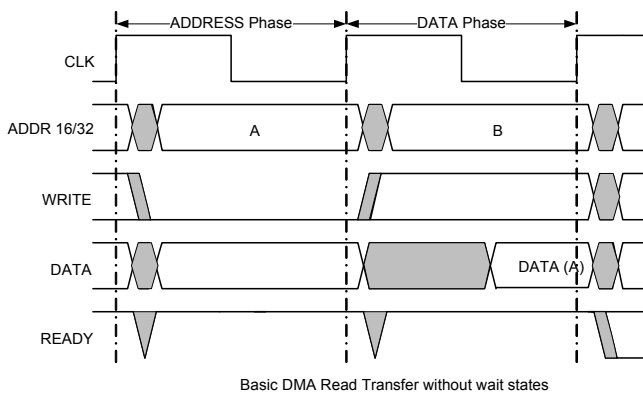

4.4.4.2 Auto Repeat DMA

Auto repeat DMA is typically used when a static pattern is repetitively read from system memory and written to a peripheral. This is done with a single TD that chains to itself.

4.4.4.3 Ping Pong DMA

A ping pong DMA case uses double buffering to allow one buffer to be filled by one client while another client is consuming the

data previously received in the other buffer. In its simplest form, this is done by chaining two TDs together so that each TD calls the opposite TD when complete.

4.4.4.4 Circular DMA

Circular DMA is similar to ping pong DMA except it contains more than two buffers. In this case there are multiple TDs; after the last TD is complete it chains back to the first TD.

4.4.4.5 Scatter Gather DMA

In the case of scatter gather DMA, there are multiple noncontiguous sources or destinations that are required to effectively carry out an overall DMA transaction. For example, a packet may need to be transmitted off of the device and the packet elements, including the header, payload, and trailer, exist in various noncontiguous locations in memory. Scatter gather DMA allows the segments to be concatenated together by using multiple TDs in a chain. The chain gathers the data from the multiple locations. A similar concept applies for the reception of data onto the device. Certain parts of the received data may need to be scattered to various locations in memory for software processing convenience. Each TD in the chain specifies the location for each discrete element in the chain.

4.4.4.6 Packet Queuing DMA

Packet queuing DMA is similar to scatter gather DMA but specifically refers to packet protocols. With these protocols, there may be separate configuration, data, and status phases associated with sending or receiving a packet.

For instance, to transmit a packet, a memory mapped configuration register can be written inside a peripheral, specifying the overall length of the ensuing data phase. The CPU can set up this configuration information anywhere in system memory and copy it with a simple TD to the peripheral. After the configuration phase, a data phase TD (or a series of data phase TDs) can begin (potentially using scatter gather). When the data phase TD(s) finish, a status phase TD can be invoked that reads some memory mapped status information from the peripheral and copies it to a location in system memory specified by the CPU for later inspection. Multiple sets of configuration, data, and status phase “subchains” can be strung together to create larger chains that transmit multiple packets in this way. A similar concept exists in the opposite direction to receive the packets.

4.4.4.7 Nested DMA

One TD may modify another TD, as the TD configuration space is memory mapped similar to any other peripheral. For example, a first TD loads a second TD’s configuration and then calls the second TD. The second TD moves data as required by the application. When complete, the second TD calls the first TD, which again updates the second TD’s configuration. This process repeats as often as necessary.

4.5 Interrupt Controller

The interrupt controller provides a mechanism for hardware resources to change program execution to a new address, independent of the current task being executed by the main code. The interrupt controller provides enhanced features not found on original 8051 interrupt controllers:

- Thirty-two interrupt vectors
- Jumps directly to ISR anywhere in code space with dynamic vector addresses
- Multiple sources for each vector
- Flexible interrupt to vector matching
- Each interrupt vector is independently enabled or disabled
- Each interrupt can be dynamically assigned one of eight priorities
- Eight level nestable interrupts
- Multiple I/O interrupt vectors
- Software can send interrupts
- Software can clear pending interrupts

When an interrupt is pending, the current instruction is completed and the program counter is pushed onto the stack. Code execution then jumps to the program address provided by the vector. After the ISR is completed, a RETI instruction is executed and returns execution to the instruction following the previously interrupted instruction. To do this the RETI instruction pops the program counter from the stack.

If the same priority level is assigned to two or more interrupts, the interrupt with the lower vector number is executed first. Each interrupt vector may choose from three interrupt sources: Fixed Function, DMA, and UDB. The fixed function interrupts are direct connections to the most common interrupt sources and provide the lowest resource cost connection. The DMA interrupt sources provide direct connections to the two DMA interrupt sources provided per DMA channel. The third interrupt source for vectors is from the UDB digital routing array. This allows any digital signal available to the UDB array to be used as an interrupt source. Fixed function interrupts and all interrupt sources may be routed to any interrupt vector using the UDB interrupt source connections.

Figure 4-2 on page 21 represents typical flow of events when an interrupt triggered. Figure 4-3 on page 22 shows the interrupt structure and priority polling.

Figure 4-2. Interrupt Processing Timing Diagram

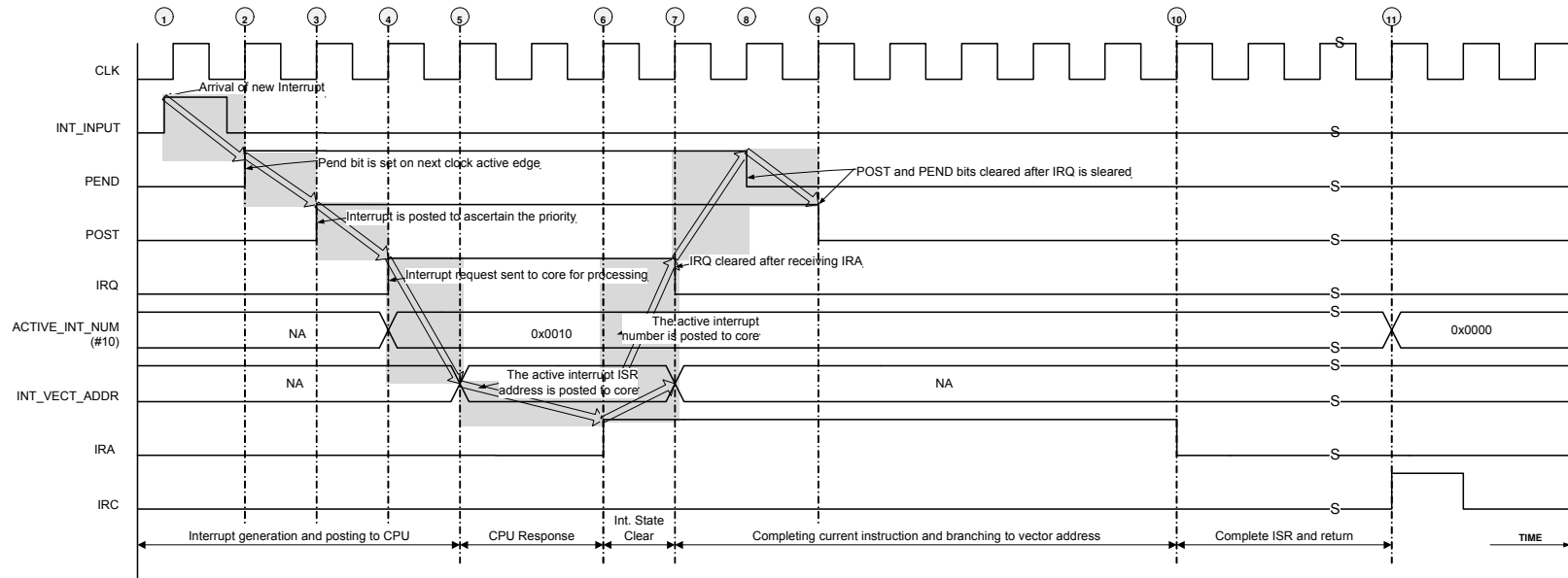

Notes

- 1: Interrupt triggered asynchronous to the clock
- 2: The PEND bit is set on next active clock edge to indicate the interrupt arrival
- 3: POST bit is set following the PEND bit
- 4: Interrupt request and the interrupt number sent to CPU core after evaluation priority (Takes 3 clocks)
- 5: ISR address is posted to CPU core for branching
- 6: CPU acknowledges the interrupt request
- 7: ISR address is read by CPU for branching
- 8, 9: PEND and POST bits are cleared respectively after receiving the IRA from core
- 10: IRA bit is cleared after completing the current instruction and starting the instruction execution from ISR location (Takes 7 cycles)
- 11: IRC is set to indicate the completion of ISR, Active int. status is restored with previous status

The total interrupt latency (ISR execution)

$$= \text{POST} + \text{PEND} + \text{IRQ} + \text{IRA} + \text{Completing current instruction and branching}$$

$$= 1+1+1+2+7 \text{ cycles}$$

$$= 12 \text{ cycles}$$

Figure 4-3. Interrupt Structure

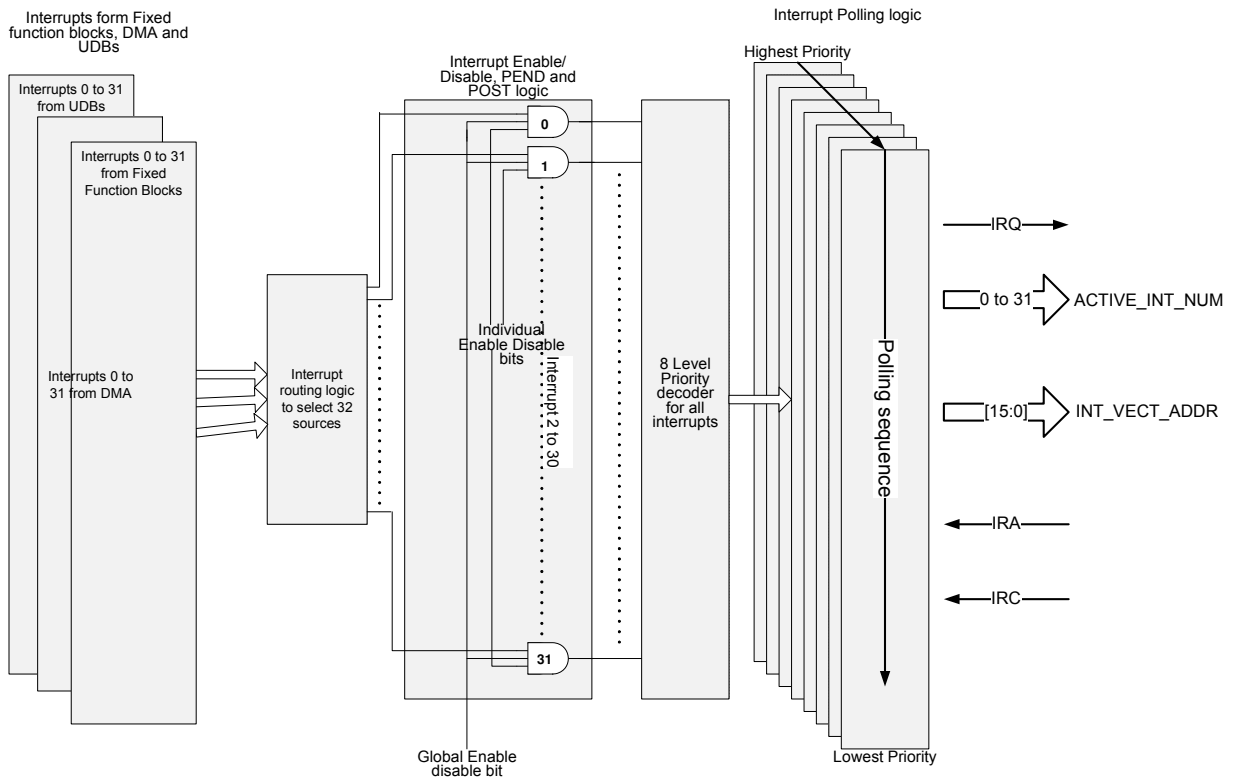

Table 4-8. Interrupt Vector Table

#	Fixed Function	DMA	UDB
0	LVD	phub_termout0[0]	udb_intr[0]
1	Cache/ECC	phub_termout0[1]	udb_intr[1]
2	Reserved	phub_termout0[2]	udb_intr[2]
3	Sleep (Pwr Mgr)	phub_termout0[3]	udb_intr[3]
4	PICU[0]	phub_termout0[4]	udb_intr[4]
5	PICU[1]	phub_termout0[5]	udb_intr[5]
6	PICU[2]	phub_termout0[6]	udb_intr[6]
7	PICU[3]	phub_termout0[7]	udb_intr[7]
8	PICU[4]	phub_termout0[8]	udb_intr[8]
9	PICU[5]	phub_termout0[9]	udb_intr[9]
10	PICU[6]	phub_termout0[10]	udb_intr[10]
11	PICU[12]	phub_termout0[11]	udb_intr[11]
12	PICU[15]	phub_termout0[12]	udb_intr[12]
13	Comparators Combined	phub_termout0[13]	udb_intr[13]
14	Switched Caps Combined	phub_termout0[14]	udb_intr[14]
15	I ² C	phub_termout0[15]	udb_intr[15]
16	CAN	phub_termout1[0]	udb_intr[16]
17	Timer/Counter0	phub_termout1[1]	udb_intr[17]
18	Timer/Counter1	phub_termout1[2]	udb_intr[18]
19	Timer/Counter2	phub_termout1[3]	udb_intr[19]
20	Timer/Counter3	phub_termout1[4]	udb_intr[20]
21	USB SOF Int	phub_termout1[5]	udb_intr[21]
22	USB Arb Int	phub_termout1[6]	udb_intr[22]

Table 4-8. Interrupt Vector Table (continued)

#	Fixed Function	DMA	UDB
23	USB Bus Int	phub_termout1[7]	udb_intr[23]
24	USB Endpoint[0]	phub_termout1[8]	udb_intr[24]
25	USB Endpoint Data	phub_termout1[9]	udb_intr[25]
26	Reserved	phub_termout1[10]	udb_intr[26]
27	LCD	phub_termout1[11]	udb_intr[27]
28	DFB Int	phub_termout1[12]	udb_intr[28]
29	Decimator Int	phub_termout1[13]	udb_intr[29]
30	PHUB Error Int	phub_termout1[14]	udb_intr[30]
31	EEPROM Fault Int	phub_termout1[15]	udb_intr[31]

5. Memory

5.1 Static RAM

CY8C36 Static RAM (SRAM) is used for temporary data storage. Up to 8 KB of SRAM is provided and can be accessed by the 8051 or the DMA controller. See [Memory Map](#) on page 26. Simultaneous access of SRAM by the 8051 and the DMA controller is possible if different 4-KB blocks are accessed.

5.2 Flash Program Memory

Flash memory in PSoC devices provides nonvolatile storage for user firmware, user configuration data, bulk data storage, and optional ECC data. The main flash memory area contains up to 64 KB of user program space.

Up to an additional 8 KB of flash space is available for ECC. If ECC is not used this space can store device configuration data and bulk user data. User code may not be run out of the ECC flash memory section. ECC can correct one bit error and detect two bit errors per 8 bytes of firmware memory; an interrupt can be generated when an error is detected.

The CPU reads instructions located in flash through a cache controller. This improves instruction execution rate and reduces system power consumption by requiring less frequent flash access. The cache has 8 lines at 64 bytes per line for a total of 512 bytes. It is fully associative, automatically controls flash power, and can be enabled or disabled. If ECC is enabled, the cache controller also performs error checking and correction, and interrupt generation.

Flash programming is performed through a special interface and preempts code execution out of flash. The flash programming interface performs flash erasing, programming and setting code protection levels. Flash in-system serial programming (ISSP), typically used for production programming, is possible through both the SWD and JTAG interfaces. In-system programming, typically used for bootloaders, is also possible using serial interfaces such as I²C, USB, UART, and SPI, or any communications protocol.

5.3 Flash Security

All PSoC devices include a flexible flash-protection model that prevents access and visibility to on-chip flash memory. This prevents duplication or reverse engineering of proprietary code. Flash memory is organized in blocks, where each block contains 256 bytes of program or data and 32 bytes of ECC or configuration data. A total of up to 256 blocks is provided on 64-KB flash devices.

The device offers the ability to assign one of four protection levels to each row of flash. [Table 5-1](#) lists the protection modes available. Flash protection levels can only be changed by performing a complete flash erase. The Full Protection and Field Upgrade settings disable external access (through a debugging tool such as PSoC Creator, for example). If your application requires code update through a boot loader, then use the Field Upgrade setting. Use the Unprotected setting only when no security is needed in your application. The PSoC device also offers an advanced security feature called Device Security that permanently disables all test, programming, and debug ports, protecting your application from external access (see [Device Security](#) on page 68). For information about how to take full advantage of the security features in PSoC, see the [PSoC 3 TRM](#).

Table 5-1. Flash Protection

Protection Setting	Allowed	Not Allowed
Unprotected	External read and write + internal read and write	–
Factory Upgrade	External write + internal read and write	External read
Field Upgrade	Internal read and write	External read and write
Full Protection	Internal read	External read and write + internal write

Disclaimer

Note the following details of the flash code protection features on Cypress devices.

Cypress products meet the specifications contained in their particular Cypress data sheets. Cypress believes that its family of products is one of the most secure families of its kind on the market today, regardless of how they are used. There may be methods, unknown to Cypress, that can breach the code protection features. Any of these methods, to our knowledge, would be dishonest and possibly illegal. Neither Cypress nor any other semiconductor manufacturer can guarantee the security of their code. Code protection does not mean that we are guaranteeing the product as “unbreakable.”

Cypress is willing to work with the customer who is concerned about the integrity of their code. Code protection is constantly evolving. We at Cypress are committed to continuously improving the code protection features of our products.

5.4 EEPROM

PSoC EEPROM memory is a byte-addressable nonvolatile memory. The CY8C36 has up to 2 KB of EEPROM memory to store user data. Reads from EEPROM are random access at the byte level. Reads are done directly; writes are done by sending write commands to an EEPROM programming interface. CPU code execution can continue from flash during EEPROM writes. EEPROM is erasable and writable at the row level. The EEPROM is divided into 128 rows of 16 bytes each. The factory default values of all EEPROM bytes are 0.

Because the EEPROM is mapped to the 8051 xdata space, the CPU cannot execute out of EEPROM. There is no ECC hardware associated with EEPROM. If ECC is required it must be handled in firmware.

It can take as much as 20 milliseconds to write to EEPROM or flash. During this time the device should not be reset, or unexpected changes may be made to portions of EEPROM or flash. Reset sources (see [Section 6.3.1](#)) include XRES pin, software reset, and watchdog; care should be taken to make sure that these are not inadvertently activated. In addition, the low voltage detect circuits should be configured to generate an interrupt instead of a reset.

5.5 Nonvolatile Latches (NVLs)

PSoC has a 4-byte array of nonvolatile latches (NVLs) that are used to configure the device at reset. The NVL register map is shown in [Table 5-2](#).

Table 5-2. Device Configuration NVL Register Map

Register Address	7	6	5	4	3	2	1	0
0x00	PRT3RDM[1:0]		PRT2RDM[1:0]		PRT1RDM[1:0]		PRT0RDM[1:0]	
0x01	PRT12RDM[1:0]		PRT6RDM[1:0]		PRT5RDM[1:0]		PRT4RDM[1:0]	
0x02	XRESMEN	DBGEN					PRT15RDM[1:0]	
0x03	DIG_PHS_DLY[3:0]				ECCEN	DPS[1:0]		CFGSPD

The details for individual fields and their factory default settings are shown in [Table 5-3](#).

Table 5-3. Fields and Factory Default Settings

Field	Description	Settings
PRTxRDM[1:0]	Controls reset drive mode of the corresponding IO port. See “Reset Configuration” on page 43. All pins of the port are set to the same mode.	00b (default) - high impedance analog 01b - high impedance digital 10b - resistive pull up 11b - resistive pull down
XRESMEN	Controls whether pin P1[2] is used as a GPIO or as an external reset. See “Pin Descriptions” on page 12, XRES description.	0 (default for 68-pin 72-pin, and 100-pin parts) - GPIO 1 (default for 48-pin parts) - external reset
DBGEN	Debug Enable allows access to the debug system, for third-party programmers.	0 - access disabled 1 (default) - access enabled
CFGSPD	Controls the speed of the IMO-based clock during the device boot process, for faster boot or low-power operation	0 (default) - 12 MHz IMO 1 - 48 MHz IMO
DPS[1:0]	Controls the usage of various P1 pins as a debug port. See “Programming, Debug Interfaces, Resources” on page 65.	00b - 5-wire JTAG 01b (default) - 4-wire JTAG 10b - SWD 11b - debug ports disabled
ECCEN	Controls whether ECC flash is used for ECC or for general configuration and data storage. See “Flash Program Memory” on page 23.	0 - ECC disabled 1 (default) - ECC enabled
DIG_PHS_DLY[3:0]	Selects the digital clock phase delay.	See the TRM for details.

Although PSoC Creator provides support for modifying the device configuration NVLs, the number of NVL erase / write cycles is limited – see [“Nonvolatile Latches \(NVL\)”](#) on page 110.

5.6 External Memory Interface

CY8C36 provides an external memory interface (EMIF) for connecting to external memory devices. The connection allows read and write accesses to external memories. The EMIF operates in conjunction with UDBs, I/O ports, and other hardware to generate external memory address and control signals. At 33 MHz, each memory access cycle takes four bus clock cycles.

Figure 5-1 is the EMIF block diagram. The EMIF supports synchronous and asynchronous memories. The CY8C36 supports only one type of external memory device at a time.

External memory can be accessed through the 8051 xdata space; up to 24 address bits can be used. See [xdata Space](#) on page 27. The memory can be 8 or 16 bits wide.

Figure 5-1. EMIF Block Diagram

