



Chipsmall Limited consists of a professional team with an average of over 10 year of expertise in the distribution of electronic components. Based in Hongkong, we have already established firm and mutual-benefit business relationships with customers from,Europe,America and south Asia,supplying obsolete and hard-to-find components to meet their specific needs.

With the principle of “Quality Parts,Customers Priority,Honest Operation,and Considerate Service”,our business mainly focus on the distribution of electronic components. Line cards we deal with include Microchip,ALPS,ROHM,Xilinx,Pulse,ON,Everlight and Freescale. Main products comprise IC,Modules,Potentiometer,IC Socket,Relay,Connector.Our parts cover such applications as commercial,industrial, and automotives areas.

We are looking forward to setting up business relationship with you and hope to provide you with the best service and solution. Let us make a better world for our industry!



Contact us

Tel: +86-755-8981 8866 Fax: +86-755-8427 6832

Email & Skype: info@chipsmall.com Web: www.chipsmall.com

Address: A1208, Overseas Decoration Building, #122 Zhenhua RD., Futian, Shenzhen, China



General Description

PSoC® 4 is a scalable and reconfigurable platform architecture for a family of programmable embedded system controllers with an ARM® Cortex®-M0+ CPU. It combines programmable and reconfigurable analog and digital blocks with flexible automatic routing. The PSoC 4000S product family is a member of the PSoC 4 platform architecture. It is a combination of a microcontroller with standard communication and timing peripherals, a capacitive touch-sensing system (CapSense) with best-in-class performance, programmable general-purpose continuous-time and switched-capacitor analog blocks, and programmable connectivity. PSoC 4000S products will be upward compatible with members of the PSoC 4 platform for new applications and design needs.

Features

32-bit MCU Subsystem

- 48-MHz ARM Cortex-M0+ CPU
- Up to 32 KB of flash with Read Accelerator
- Up to 4 KB of SRAM

Programmable Analog

- Single-slope 10-bit ADC function provided by Capacitance sensing block
- Two current DACs (IDACs) for general-purpose or capacitive sensing applications on any pin
- Two low-power comparators that operate in Deep Sleep low-power mode

Programmable Digital

Programmable logic blocks allowing Boolean operations to be performed on port inputs and outputs

Low-Power 1.71-V to 5.5-V Operation

- Deep Sleep mode with operational analog and 2.5 μ A digital system current

Capacitive Sensing

- Cypress CapSense Sigma-Delta (CSD) provides best-in-class signal-to-noise ratio (SNR) (>5:1) and water tolerance
- Cypress-supplied software component makes capacitive sensing design easy
- Automatic hardware tuning (SmartSense™)

Serial Communication

- Two independent run-time reconfigurable Serial Communication Blocks (SCBs) with re-configurable I2C, SPI, or UART functionality

LCD Drive Capability

- LCD segment drive capability on GPIOs

Timing and Pulse-Width Modulation

- Five 16-bit timer/counter/pulse-width modulator (TCPWM) blocks
- Center-aligned, Edge, and Pseudo-random modes
- Comparator-based triggering of Kill signals for motor drive and other high-reliability digital logic applications

Up to 36 Programmable GPIO Pins

- 48-pin TQFP, 40-pin QFN, 32-pin QFN, 24-pin QFN, and 25-ball WLCSP packages
- Any GPIO pin can be CapSense, analog, or digital
- Drive modes, strengths, and slew rates are programmable

PSoC Creator Design Environment

- Integrated Development Environment (IDE) provides schematic design entry and build (with analog and digital automatic routing)
- Applications Programming Interface (API) component for all fixed-function and programmable peripherals

Industry-Standard Tool Compatibility

- After schematic entry, development can be done with ARM-based industry-standard development tools

Contents

Functional Definition	4	Analog Peripherals	16
CPU and Memory Subsystem	4	Digital Peripherals	19
System Resources	4	Memory	22
Analog Blocks.....	5	System Resources	22
Programmable Digital Blocks	5	Ordering Information	25
Fixed Function Digital.....	5	Packaging	27
GPIO	6	Package Diagrams	28
Special Function Peripherals	6	Acronyms	31
Pinouts	7	Document Conventions	33
Alternate Pin Functions	8	Units of Measure	33
Power	10	Revision History	34
Mode 1: 1.8 V to 5.5 V External Supply	10	Sales, Solutions, and Legal Information	35
Mode 2: 1.8 V ±5% External Supply.....	10	Worldwide Sales and Design Support.....	35
Development Support	11	Products	35
Documentation	11	PSoC® Solutions	35
Online	11	Cypress Developer Community.....	35
Tools.....	11	Technical Support	35
Electrical Specifications	12		
Absolute Maximum Ratings.....	12		
Device Level Specifications.....	12		

Figure 1. Block Diagram

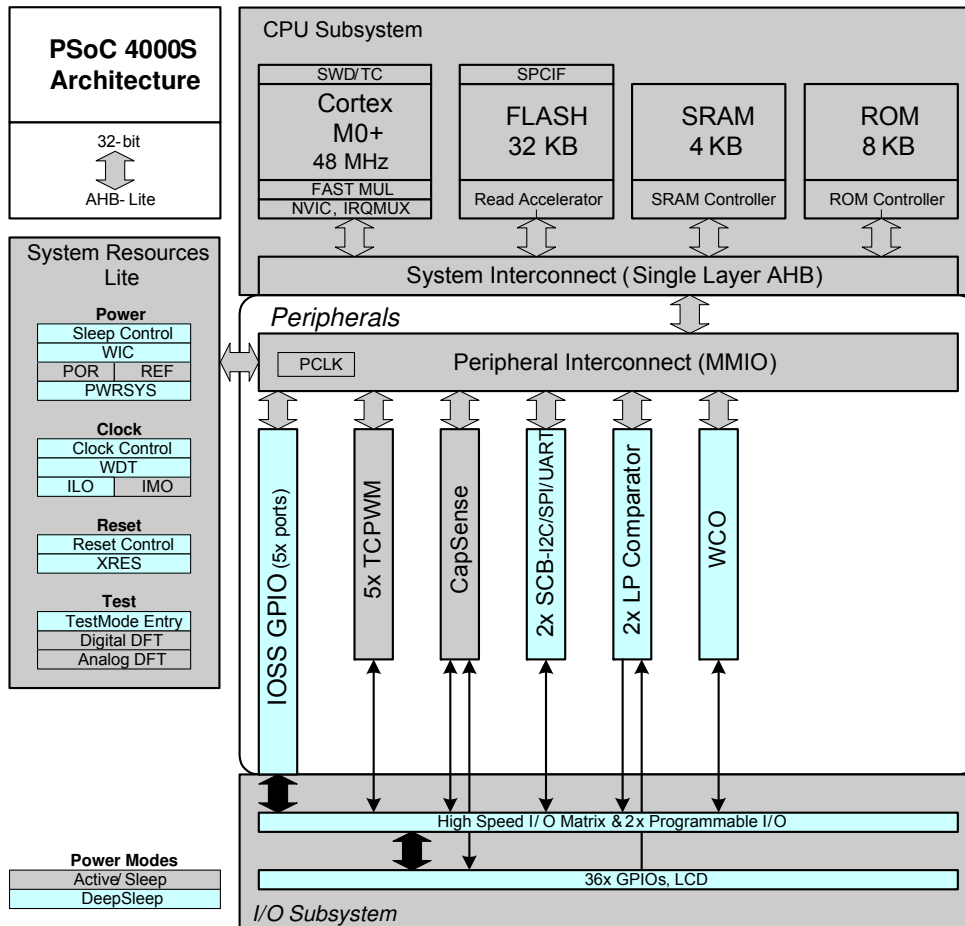

PSoC 4000S devices include extensive support for programming, testing, debugging, and tracing both hardware and firmware.

The ARM Serial-Wire Debug (SWD) interface supports all programming and debug features of the device.

Complete debug-on-chip functionality enables full-device debugging in the final system using the standard production device. It does not require special interfaces, debugging pods, simulators, or emulators. Only the standard programming connections are required to fully support debug.

The PSoC Creator IDE provides fully integrated programming and debug support for the PSoC 4000S devices. The SWD interface is fully compatible with industry-standard third-party tools. The PSoC 4000S family provides a level of security not possible with multi-chip application solutions or with microcontrollers. It has the following advantages:

- Allows disabling of debug features
- Robust flash protection
- Allows customer-proprietary functionality to be implemented in on-chip programmable blocks

The debug circuits are enabled by default and can be disabled in firmware. If they are not enabled, the only way to re-enable them is to erase the entire device, clear flash protection, and reprogram the device with new firmware that enables debugging. Thus firmware control of debugging cannot be over-ridden without erasing the firmware thus providing security.

Additionally, all device interfaces can be permanently disabled (device security) for applications concerned about phishing attacks due to a maliciously reprogrammed device or attempts to defeat security by starting and interrupting flash programming sequences. All programming, debug, and test interfaces are disabled when maximum device security is enabled. Therefore, PSoC 4000S, with device security enabled, may not be returned for failure analysis. This is a trade-off the PSoC 4000S allows the customer to make.

Functional Definition

CPU and Memory Subsystem

CPU

The Cortex-M0+ CPU in the PSoC 4000S is part of the 32-bit MCU subsystem, which is optimized for low-power operation with extensive clock gating. Most instructions are 16 bits in length and the CPU executes a subset of the Thumb-2 instruction set. It includes a nested vectored interrupt controller (NVIC) block with eight interrupt inputs and also includes a Wakeup Interrupt Controller (WIC). The WIC can wake the processor from Deep Sleep mode, allowing power to be switched off to the main processor when the chip is in Deep Sleep mode.

The CPU also includes a debug interface, the serial wire debug (SWD) interface, which is a two-wire form of JTAG. The debug configuration used for PSoC 4000S has four breakpoint (address) comparators and two watchpoint (data) comparators.

Flash

The PSoC 4000S device has a flash module with a flash accelerator, tightly coupled to the CPU to improve average access times from the flash block. The low-power flash block is designed to deliver two wait-state (WS) access time at 48 MHz. The flash accelerator delivers 85% of single-cycle SRAM access performance on average.

SRAM

Four KB of SRAM are provided with zero wait-state access at 48 MHz.

SROM

A supervisory ROM that contains boot and configuration routines is provided.

System Resources

Power System

The power system is described in detail in the section [Power on page 10](#). It provides assurance that voltage levels are as required for each respective mode and either delays mode entry (for example, on power-on reset (POR)) until voltage levels are as required for proper functionality, or generates resets (for example, on brown-out detection). The PSoC 4000S operates with a single external supply over the range of either 1.8 V \pm 5% (externally regulated) or 1.8 to 5.5 V (internally regulated) and has three different power modes, transitions between which are managed by the power system. The PSoC 4000S provides Active, Sleep, and Deep Sleep low-power modes.

All subsystems are operational in Active mode. The CPU subsystem (CPU, flash, and SRAM) is clock-gated off in Sleep mode, while all peripherals and interrupts are active with instantaneous wake-up on a wake-up event. In Deep Sleep mode, the high-speed clock and associated circuitry is switched off; wake-up from this mode takes 35 μ s. The opamps can remain operational in Deep Sleep mode.

Clock System

The PSoC 4000S clock system is responsible for providing clocks to all subsystems that require clocks and for switching between different clock sources without glitching. In addition, the clock system ensures that there are no metastable conditions.

The clock system for the PSoC 4000S consists of the internal main oscillator (IMO), internal low-frequency oscillator (ILO), a 32 kHz Watch Crystal Oscillator (WCO) and provision for an external clock. Clock dividers are provided to generate clocks for peripherals on a fine-grained basis. Fractional dividers are also provided to enable clocking of higher data rates for UARTs.

The HFCLK signal can be divided down to generate synchronous clocks for the analog and digital peripherals. There are eight clock dividers for the PSoC 4000S, two of those are fractional dividers. The 16-bit capability allows flexible generation of fine-grained frequency values, and is fully supported in PSoC Creator.

Figure 2. PSoC 4000S MCU Clocking Architecture

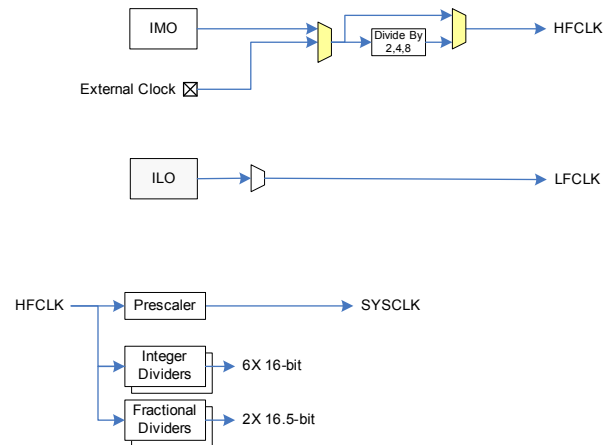

IMO Clock Source

The IMO is the primary source of internal clocking in the PSoC 4000S. It is trimmed during testing to achieve the specified accuracy. The IMO default frequency is 24 MHz and it can be adjusted from 24 to 48 MHz in steps of 4 MHz. The IMO tolerance with Cypress-provided calibration settings is \pm 2%.

ILO Clock Source

The ILO is a very low power, nominally 40-kHz oscillator, which is primarily used to generate clocks for the watchdog timer (WDT) and peripheral operation in Deep Sleep mode. ILO-driven counters can be calibrated to the IMO to improve accuracy. Cypress provides a software component, which does the calibration.

Watch Crystal Oscillator (WCO)

The PSoC 4000S clock subsystem also implements a low-frequency (32-kHz watch crystal) oscillator that can be used for precision timing applications.

Watchdog Timer

A watchdog timer is implemented in the clock block running from the ILO; this allows watchdog operation during Deep Sleep and generates a watchdog reset if not serviced before the set timeout occurs. The watchdog reset is recorded in a Reset Cause register, which is firmware readable.

Reset

The PSoC 4000S can be reset from a variety of sources including a software reset. Reset events are asynchronous and guarantee reversion to a known state. The reset cause is recorded in a register, which is sticky through reset and allows software to determine the cause of the reset. An XRES pin is reserved for external reset by asserting it active low. The XRES pin has an internal pull-up resistor that is always enabled.

Voltage Reference

The PSoC 4000S reference system generates all internally required references. A 1.2-V voltage reference is provided for the comparator. The IDACs are based on a $\pm 5\%$ reference.

Analog Blocks

Low-power Comparators (LPC)

The PSoC 4000S has a pair of low-power comparators, which can also operate in Deep Sleep modes. This allows the analog system blocks to be disabled while retaining the ability to monitor external voltage levels during low-power modes. The comparator outputs are normally synchronized to avoid metastability unless operating in an asynchronous power mode where the system wake-up circuit is activated by a comparator switch event. The LPC outputs can be routed to pins.

Current DACs

The PSoC 4000S has two IDACs, which can drive any of the pins on the chip. These IDACs have programmable current ranges.

Analog Multiplexed Buses

The PSoC 4000S has two concentric independent buses that go around the periphery of the chip. These buses (called amux buses) are connected to firmware-programmable analog switches that allow the chip's internal resources (IDACs, comparator) to connect to any pin on the I/O Ports.

Programmable Digital Blocks

The programmable I/O (Smart I/O) block is a fabric of switches and LUTs that allows Boolean functions to be performed in signals being routed to the pins of a GPIO port. The Smart I/O can perform logical operations on input pins to the chip and on signals going out as outputs.

Fixed Function Digital

Timer/Counter/PWM (TCPWM) Block

The TCPWM block consists of a 16-bit counter with user-programmable period length. There is a capture register to record the count value at the time of an event (which may be an I/O event), a period register that is used to either stop or auto-reload the counter when its count is equal to the period register, and compare registers to generate compare value signals that are used as PWM duty cycle outputs. The block also provides true and complementary outputs with programmable offset between them to allow use as dead-band programmable complementary PWM outputs. It also has a Kill input to force outputs to a predetermined state; for example, this is used in motor drive systems when an over-current state is indicated and the PWM driving the FETs needs to be shut off immediately with no time for software intervention. There are five TCPWM blocks in the PSoC 4000S.

Serial Communication Block (SCB)

The PSoC 4000S has two serial communication blocks, which can be programmed to have SPI, I2C, or UART functionality.

I²C Mode: The hardware I²C block implements a full multi-master and slave interface (it is capable of multi-master arbitration). This block is capable of operating at speeds of up to 400 kbps (Fast Mode) and has flexible buffering options to reduce interrupt overhead and latency for the CPU. It also supports EZI2C that creates a mailbox address range in the memory of the PSoC 4000S and effectively reduces I²C communication to reading from and writing to an array in memory. In addition, the block supports an 8-deep FIFO for receive and transmit which, by increasing the time given for the CPU to read data, greatly reduces the need for clock stretching caused by the CPU not having read data on time.

The I²C peripheral is compatible with the I²C Standard-mode and Fast-mode devices as defined in the NXP I²C-bus specification and user manual (UM10204). The I²C bus I/O is implemented with GPIO in open-drain modes.

The PSoC 4000S is not completely compliant with the I²C spec in the following respect:

- GPIO cells are not overvoltage tolerant and, therefore, cannot be hot-swapped or powered up independently of the rest of the I²C system.

UART Mode: This is a full-feature UART operating at up to 1 Mbps. It supports automotive single-wire interface (LIN), infrared interface (IrDA), and SmartCard (ISO7816) protocols, all of which are minor variants of the basic UART protocol. In addition, it supports the 9-bit multiprocessor mode that allows addressing of peripherals connected over common RX and TX lines. Common UART functions such as parity error, break detect, and frame error are supported. An 8-deep FIFO allows much greater CPU service latencies to be tolerated.

SPI Mode: The SPI mode supports full Motorola SPI, TI SSP (adds a start pulse used to synchronize SPI Coders), and National Microwire (half-duplex form of SPI). The SPI block can use the FIFO.

GPIO

The PSoC 4000S has up to 36 GPIOs. The GPIO block implements the following:

- Eight drive modes:
 - Analog input mode (input and output buffers disabled)
 - Input only
 - Weak pull-up with strong pull-down
 - Strong pull-up with weak pull-down
 - Open drain with strong pull-down
 - Open drain with strong pull-up
 - Strong pull-up with strong pull-down
 - Weak pull-up with weak pull-down
- Input threshold select (CMOS or LVTTL).
- Individual control of input and output buffer enabling/disabling in addition to the drive strength modes
- Selectable slew rates for dV/dt related noise control to improve EMI

The pins are organized in logical entities called ports, which are 8-bit in width (less for Ports 2 and 3). During power-on and reset, the blocks are forced to the disable state so as not to crowbar any inputs and/or cause excess turn-on current. A multiplexing network known as a high-speed I/O matrix is used to multiplex between various signals that may connect to an I/O pin.

Data output and pin state registers store, respectively, the values to be driven on the pins and the states of the pins themselves.

Every I/O pin can generate an interrupt if so enabled and each I/O port has an interrupt request (IRQ) and interrupt service routine (ISR) vector associated with it (5 for PSoC 4000S).

Special Function Peripherals

CapSense

CapSense is supported in the PSoC 4000S through a CapSense Sigma-Delta (CSD) block that can be connected to any pins through an analog multiplex bus via analog switches. CapSense function can thus be provided on any available pin or group of pins in a system under software control. A PSoC Creator component is provided for the CapSense block to make it easy for the user.

Shield voltage can be driven on another analog multiplex bus to provide water-tolerance capability. Water tolerance is provided by driving the shield electrode in phase with the sense electrode to keep the shield capacitance from attenuating the sensed input. Proximity sensing can also be implemented.

The CapSense block has two IDACs, which can be used for general purposes if CapSense is not being used (both IDACs are available in that case) or if CapSense is used without water tolerance (one IDAC is available).

The CapSense block also provides a 10-bit Slope ADC function, which can be used in conjunction with the CapSense function.

The CapSense block is an advanced, low-noise, programmable block with programmable voltage references and current source ranges for improved sensitivity and flexibility. It can also use an external reference voltage. It has a full-wave CSD mode that alternates sensing to VDDA and Ground to null out power-supply related noise.

LCD Segment Drive

The PSoC 4000S has an LCD controller, which can drive up to 8 commons and up to 28 segments. It uses full digital methods to drive the LCD segments requiring no generation of internal LCD voltages. The two methods used are referred to as Digital Correlation and PWM. Digital Correlation pertains to modulating the frequency and drive levels of the common and segment signals to generate the highest RMS voltage across a segment to light it up or to keep the RMS signal to zero. This method is good for STN displays but may result in reduced contrast with TN (cheaper) displays. PWM pertains to driving the panel with PWM signals to effectively use the capacitance of the panel to provide the integration of the modulated pulse-width to generate the desired LCD voltage. This method results in higher power consumption but can result in better results when driving TN displays. LCD operation is supported during Deep Sleep refreshing a small display buffer (4 bits; 1 32-bit register per port).

Pinouts

The following table provides the pin list for PSoc 4000S for the 48-pin TQFP, 40-pin QFN, 32-pin QFN, 24-pin QFN, and 25-ball CSP packages. All port pins support GPIO. Pin 11 is a No-Connect in the 48-TQFP.

Table 1. PSoc 4000S Pin List

48-TQFP		32-QFN		24-QFN		25-CSP		40-QFN	
Pin	Name	Pin	Name	Pin	Name	Pin	Name	Pin	Name
28	P0.0	17	P0.0	13	P0.0	D1	P0.0	22	P0.0
29	P0.1	18	P0.1	14	P0.1	C3	P0.1	23	P0.1
30	P0.2	19	P0.2					24	P0.2
31	P0.3	20	P0.3					25	P0.3
32	P0.4	21	P0.4	15	P0.4	C2	P0.4	26	P0.4
33	P0.5	22	P0.5	16	P0.5	C1	P0.5	27	P0.5
34	P0.6	23	P0.6	17	P0.6	B1	P0.6	28	P0.6
35	P0.7					B2	P0.7	29	P0.7
36	XRES	24	XRES	18	XRES	B3	XRES	30	XRES
37	VCCD	25	VCCD	19	VCCD	A1	VCCD	31	VCCD
38	VSSD	26	VSSD	20	VSSD	A2	VSS		
39	VDDD	27	VDD	21	VDD	A3	VDD	32	VDDD
40	VDDA	27	VDD	21	VDD	A3	VDD	33	VDDA
41	VSSA	28	VSSA	22	VSSA	A2	VSS	34	VSSA
42	P1.0	29	P1.0					35	P1.0
43	P1.1	30	P1.1					36	P1.1
44	P1.2	31	P1.2	23	P1.2	A4	P1.2	37	P1.2
45	P1.3	32	P1.3	24	P1.3	B4	P1.3	38	P1.3
46	P1.4							39	P1.4
47	P1.5								
48	P1.6								
1	P1.7	1	P1.7	1	P1.7	A5	P1.7	40	P1.7
2	P2.0	2	P2.0	2	P2.0	B5	P2.0	1	P2.0
3	P2.1	3	P2.1	3	P2.1	C5	P2.1	2	P2.1
4	P2.2	4	P2.2					3	P2.2
5	P2.3	5	P2.3					4	P2.3
6	P2.4							5	P2.4
7	P2.5	6	P2.5					6	P2.5
8	P2.6	7	P2.6	4	P2.6	D5	P2.6	7	P2.6
9	P2.7	8	P2.7	5	P2.7	C4	P2.7	8	P2.7
10	VSSD					A2	VSS	9	VSSD
12	P3.0	9	P3.0	6	P3.0	E5	P3.0	10	P3.0
13	P3.1	10	P3.1			D4	P3.1	11	P3.1
14	P3.2	11	P3.2	7	P3.2	E4	P3.2	12	P3.2
16	P3.3	12	P3.3	8	P3.3	D3	P3.3	13	P3.3

Table 1. PSoC 4000S Pin List (continued)

48-TQFP		32-QFN		24-QFN		25-CSP		40-QFN	
Pin	Name	Pin	Name	Pin	Name	Pin	Name	Pin	Name
17	P3.4							14	P3.4
18	P3.5							15	P3.5
19	P3.6							16	P3.6
20	P3.7							17	P3.7
21	VDDD								
22	P4.0	13	P4.0	9	P4.0	E3	P4.0	18	P4.0
23	P4.1	14	P4.1	10	P4.1	D2	P4.1	19	P4.1
24	P4.2	15	P4.2	11	P4.2	E2	P4.2	20	P4.2
25	P4.3	16	P4.3	12	P4.3	E1	P4.3	21	P4.3

Descriptions of the Pin functions are as follows:

VDDD: Power supply for the digital section.

VDDA: Power supply for the analog section.

VSSD, VSSA: Ground pins for the digital and analog sections respectively.

VCCD: Regulated digital supply (1.8 V ±5%)

VDD: Power supply to all sections of the chip

VSS: Ground for all sections of the chip

Alternate Pin Functions

Each port pin can be assigned to one of multiple functions; it can, for instance, be an analog I/O, a digital peripheral function, an LCD pin, or a CapSense pin. The pin assignments are shown in the following table.

Port/ Pin	Analog	Smart I/O	Alternate Function 1	Alternate Function 2	Alternate Function 3	Deep Sleep 1	Deep Sleep 2
P0.0	lpcomp.in_p[0]				tcpwm.tr_in[0]		scb[0].spi_select1:0
P0.1	lpcomp.in_n[0]				tcpwm.tr_in[1]		scb[0].spi_select2:0
P0.2	lpcomp.in_p[1]						scb[0].spi_select3:0
P0.3	lpcomp.in_n[1]						
P0.4	wco.wco_in			scb[1].uart_rx:0		scb[1].i2c_scl:0	scb[1].spi_mosi:1
P0.5	wco.wco_out			scb[1].uart_tx:0		scb[1].i2c_sda:0	scb[1].spi_miso:1
P0.6			srss.ext_clk	scb[1].uart_cts:0			scb[1].spi_clk:1
P0.7				scb[1].uart_rts:0			scb[1].spi_select0:1
P1.0			tcpwm.line[2]:1	scb[0].uart_rx:1		scb[0].i2c_scl:0	scb[0].spi_mosi:1
P1.1			tcpwm.line_compl[2]:1	scb[0].uart_tx:1		scb[0].i2c_sda:0	scb[0].spi_miso:1
P1.2			tcpwm.line[3]:1	scb[0].uart_cts:1	tcpwm.tr_in[2]		scb[0].spi_clk:1
P1.3			tcpwm.line_compl[3]:1	scb[0].uart_rts:1	tcpwm.tr_in[3]		scb[0].spi_select0:1
P1.4							scb[0].spi_select1:1
P1.5							scb[0].spi_select2:1

Port/ Pin	Analog	Smart I/O	Alternate Function 1	Alternate Function 2	Alternate Function 3	Deep Sleep 1	Deep Sleep 2
P1.6							scb[0].spi_select3:1
P1.7							
P2.0		prgio[0].io[0]	tcpwm.line[4]:0	csd.comp	tcpwm.tr_in[4]	scb[1].i2c_scl:1	scb[1].spi_mosi:2
P2.1		prgio[0].io[1]	tcpwm.line_compl[4]:0		tcpwm.tr_in[5]	scb[1].i2c_sda:1	scb[1].spi_miso:2
P2.2		prgio[0].io[2]					scb[1].spi_clk:2
P2.3		prgio[0].io[3]					scb[1].spi_select0:2
P2.4		prgio[0].io[4]	tcpwm.line[0]:1				scb[1].spi_select1:1
P2.5		prgio[0].io[5]	tcpwm.line_compl[0]:1				scb[1].spi_select2:1
P2.6		prgio[0].io[6]	tcpwm.line[1]:1				scb[1].spi_select3:1
P2.7		prgio[0].io[7]	tcpwm.line_compl[1]:1			lpcomp.comp[0]:1	
P3.0		prgio[1].io[0]	tcpwm.line[0]:0	scb[1].uart_rx:1		scb[1].i2c_scl:2	scb[1].spi_mosi:0
P3.1		prgio[1].io[1]	tcpwm.line_compl[0]:0	scb[1].uart_tx:1		scb[1].i2c_sda:2	scb[1].spi_miso:0
P3.2		prgio[1].io[2]	tcpwm.line[1]:0	scb[1].uart_cts:1		cpuss.swd_data	scb[1].spi_clk:0
P3.3		prgio[1].io[3]	tcpwm.line_compl[1]:0	scb[1].uart_rts:1		cpuss.swd_clk	scb[1].spi_select0:0
P3.4		prgio[1].io[4]	tcpwm.line[2]:0		tcpwm.tr_in[6]		scb[1].spi_select1:0
P3.5		prgio[1].io[5]	tcpwm.line_compl[2]:0		tcpwm.tr_in[7]		scb[1].spi_select2:0
P3.6		prgio[1].io[6]	tcpwm.line[3]:0		tcpwm.tr_in[8]		scb[1].spi_select3:0
P3.7		prgio[1].io[7]	tcpwm.line_compl[3]:0		tcpwm.tr_in[9]	lpcomp.comp[1]:1	
P4.0	csd.vref_ext			scb[0].uart_rx:0	tcpwm.tr_in[10]	scb[0].i2c_scl:1	scb[0].spi_mosi:0
P4.1	csd.cshieldpads			scb[0].uart_tx:0	tcpwm.tr_in[11]	scb[0].i2c_sda:1	scb[0].spi_miso:0
P4.2	csd.cmodpad			scb[0].uart_cts:0		lpcomp.comp[0]:0	scb[0].spi_clk:0
P4.3	csd.csh_tank			scb[0].uart_rts:0		lpcomp.comp[1]:0	scb[0].spi_select0:0

Power

The following power system diagram shows the set of power supply pins as implemented for the PSoc 4000S. The system has one regulator in Active mode for the digital circuitry. There is no analog regulator; the analog circuits run directly from the V_{DD} input.

Figure 3. Power Supply Connections

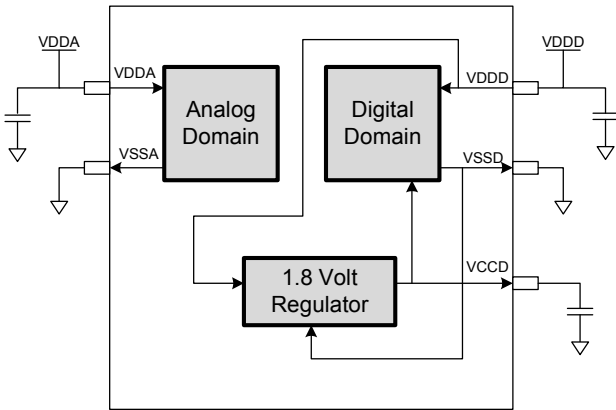

There are two distinct modes of operation. In Mode 1, the supply voltage range is 1.8 V to 5.5 V (unregulated externally; internal regulator operational). In Mode 2, the supply range is 1.8 V ±5% (externally regulated; 1.71 to 1.89, internal regulator bypassed).

Figure 4. External Supply Range from 1.8 V to 5.5 V with Internal Regulator Active

Power supply bypass connections example

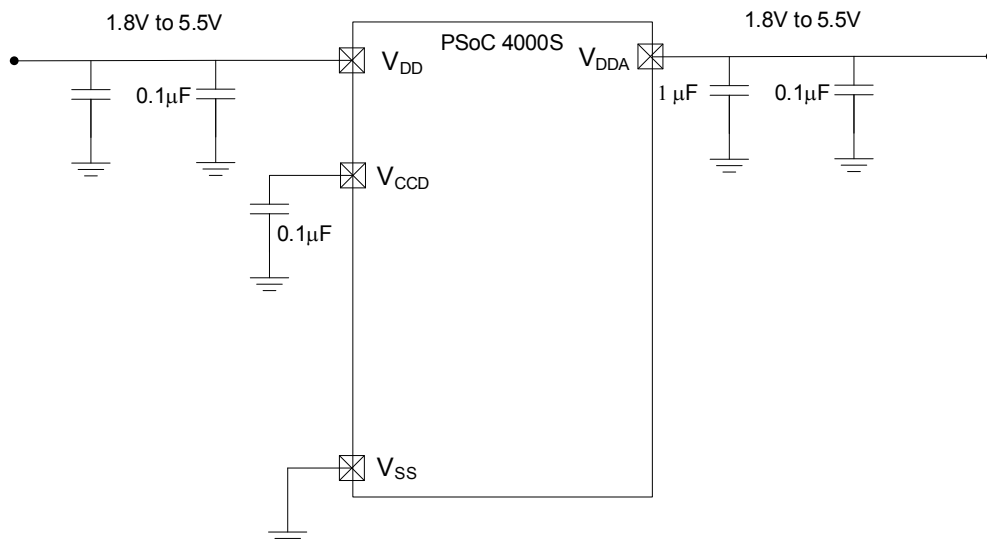

Mode 1: 1.8 V to 5.5 V External Supply

In this mode, the PSoc 4000S is powered by an external power supply that can be anywhere in the range of 1.8 to 5.5 V. This range is also designed for battery-powered operation. For example, the chip can be powered from a battery system that starts at 3.5 V and works down to 1.8 V. In this mode, the internal regulator of the PSoc 4000S supplies the internal logic and its output is connected to the V_{CCD} pin. The V_{CCD} pin must be bypassed to ground via an external capacitor (0.1 µF; X5R ceramic or better) and must not be connected to anything else.

Mode 2: 1.8 V ±5% External Supply

In this mode, the PSoc 4000S is powered by an external power supply that must be within the range of 1.71 to 1.89 V; note that this range needs to include the power supply ripple too. In this mode, the V_{DD} and V_{CCD} pins are shorted together and bypassed. The internal regulator can be disabled in the firmware.

Bypass capacitors must be used from V_{DDD} to ground. The typical practice for systems in this frequency range is to use a capacitor in the 1-µF range, in parallel with a smaller capacitor (0.1 µF, for example). Note that these are simply rules of thumb and that, for critical applications, the PCB layout, lead inductance, and the bypass capacitor parasitic should be simulated to design and obtain optimal bypassing.

An example of a bypass scheme is shown in the following diagram.

Development Support

The PSoC 4000S family has a rich set of documentation, development tools, and online resources to assist you during your development process. Visit www.cypress.com/go/psoc4 to find out more.

Documentation

A suite of documentation supports the PSoC 4000S family to ensure that you can find answers to your questions quickly. This section contains a list of some of the key documents.

Software User Guide: A step-by-step guide for using PSoC Creator. The software user guide shows you how the PSoC Creator build process works in detail, how to use source control with PSoC Creator, and much more.

Component Datasheets: The flexibility of PSoC allows the creation of new peripherals (components) long after the device has gone into production. Component data sheets provide all of the information needed to select and use a particular component, including a functional description, API documentation, example code, and AC/DC specifications.

Application Notes: PSoC application notes discuss a particular application of PSoC in depth; examples include brushless DC motor control and on-chip filtering. Application notes often include example projects in addition to the application note document.

Technical Reference Manual: The Technical Reference Manual (TRM) contains all the technical detail you need to use a PSoC device, including a complete description of all PSoC registers. The TRM is available in the Documentation section at www.cypress.com/psoc4.

Online

In addition to print documentation, the Cypress PSoC forums connect you with fellow PSoC users and experts in PSoC from around the world, 24 hours a day, 7 days a week.

Tools

With industry standard cores, programming, and debugging interfaces, the PSoC 4000S family is part of a development tool ecosystem. Visit us at www.cypress.com/go/psoccreator for the latest information on the revolutionary, easy to use PSoC Creator IDE, supported third party compilers, programmers, debuggers, and development kits.

Electrical Specifications

Absolute Maximum Ratings

Table 2. Absolute Maximum Ratings^[1]

Spec ID#	Parameter	Description	Min	Typ	Max	Units	Details/Conditions
SID1	V _{DDD_ABS}	Digital supply relative to V _{SS}	-0.5	-	6	V	-
SID2	V _{CCD_ABS}	Direct digital core voltage input relative to V _{SS}	-0.5	-	1.95		-
SID3	V _{GPIO_ABS}	GPIO voltage	-0.5	-	V _{DD} +0.5		-
SID4	I _{GPIO_ABS}	Maximum current per GPIO	-25	-	25	mA	-
SID5	I _{GPIO_injection}	GPIO injection current, Max for V _{IH} > V _{DDD} , and Min for V _{IL} < V _{SS}	-0.5	-	0.5		Current injected per pin
BID44	ESD_HBM	Electrostatic discharge human body model	2200	-	-	V	-
BID45	ESD_CDM	Electrostatic discharge charged device model	500	-	-		-
BID46	LU	Pin current for latch-up	-140	-	140	mA	-

Device Level Specifications

All specifications are valid for -40 °C ≤ T_A ≤ 85 °C and T_J ≤ 100 °C, except where noted. Specifications are valid for 1.71 V to 5.5 V, except where noted.

Table 3. DC Specifications

Typical values measured at V_{DD} = 3.3 V and 25 °C.

Spec ID#	Parameter	Description	Min	Typ	Max	Units	Details/Conditions
SID53	V _{DD}	Power supply input voltage	1.8	-	5.5	V	Internally regulated supply
SID255	V _{DD}	Power supply input voltage (V _{CCD} = V _{DD} = V _{DDA})	1.71	-	1.89		Internally unregulated supply
SID54	V _{CCD}	Output voltage (for core logic)	-	1.8	-		-
SID55	C _{EFC}	External regulator voltage bypass	-	0.1	-	μF	X5R ceramic or better
SID56	C _{EXC}	Power supply bypass capacitor	-	1	-		X5R ceramic or better
Active Mode, V_{DD} = 1.8 V to 5.5 V. Typical values measured at V_{DD} = 3.3 V and 25 °C.							
SID10	I _{DD5}	Execute from flash; CPU at 6 MHz	-	1.2	2.0	mA	-
SID16	I _{DD8}	Execute from flash; CPU at 24 MHz	-	2.4	4.0		-
SID19	I _{DD11}	Execute from flash; CPU at 48 MHz	-	4.6	5.9		-
Sleep Mode, V_{DDD} = 1.8 V to 5.5 V (Regulator on)							
SID22	I _{DD17}	I ² C wakeup WDT, and Comparators on	-	1.1	1.6	mA	6 MHz
SID25	I _{DD20}	I ² C wakeup, WDT, and Comparators on	-	1.4	1.9		12 MHz

Note

- Usage above the absolute maximum conditions listed in Table 2 may cause permanent damage to the device. Exposure to Absolute Maximum conditions for extended periods of time may affect device reliability. The Maximum Storage Temperature is 150 °C in compliance with JEDEC Standard JESD22-A103, High Temperature Storage Life. When used below Absolute Maximum conditions but above normal operating conditions, the device may not operate to specification.

Table 3. DC Specifications (continued)

 Typical values measured at $V_{DD} = 3.3\text{ V}$ and $25\text{ }^{\circ}\text{C}$.

Spec ID#	Parameter	Description	Min	Typ	Max	Units	Details/ Conditions
Sleep Mode, $V_{DD} = 1.71\text{ V to }1.89\text{ V}$ (Regulator bypassed)							
SID28	I_{DD23}	I ² C wakeup, WDT, and Comparators on	–	0.7	0.9	mA	6 MHz
SID28A	I_{DD23A}	I ² C wakeup, WDT, and Comparators on	–	0.9	1.1	mA	12 MHz
Deep Sleep Mode, $V_{DD} = 1.8\text{ V to }3.6\text{ V}$ (Regulator on)							
SID31	I_{DD26}	I ² C wakeup and WDT on	–	2.5	60	μA	–
Deep Sleep Mode, $V_{DD} = 3.6\text{ V to }5.5\text{ V}$ (Regulator on)							
SID34	I_{DD29}	I ² C wakeup and WDT on	–	2.5	60	μA	–
Deep Sleep Mode, $V_{DD} = V_{CCD} = 1.71\text{ V to }1.89\text{ V}$ (Regulator bypassed)							
SID37	I_{DD32}	I ² C wakeup and WDT on	–	2.5	60	μA	–
XRES Current							
SID307	I_{DD_XR}	Supply current while XRES asserted	–	2	5	mA	–

Table 4. AC Specifications

Spec ID#	Parameter	Description	Min	Typ	Max	Units	Details/ Conditions
SID48	F_{CPU}	CPU frequency	DC	–	48	MHz	$1.71 \leq V_{DD} \leq 5.5$
SID49 ^[3]	T_{SLEEP}	Wakeup from Sleep mode	–	0	–	μs	
SID50 ^[3]	$T_{DEEPSLEEP}$	Wakeup from Deep Sleep mode	–	35	–		

Note

- Guaranteed by characterization.

GPIO

Table 5. GPIO DC Specifications

Spec ID#	Parameter	Description	Min	Typ	Max	Units	Details/ Conditions	
SID57	$V_{IH}^{[3]}$	Input voltage high threshold	$0.7 \times V_{DDD}$	–	–	V	CMOS Input	
SID58	V_{IL}	Input voltage low threshold	–	–	$0.3 \times V_{DDD}$		CMOS Input	
SID241	$V_{IH}^{[3]}$	LVTTL input, $V_{DDD} < 2.7 V$	$0.7 \times V_{DDD}$	–	–		–	
SID242	V_{IL}	LVTTL input, $V_{DDD} < 2.7 V$	–	–	$0.3 \times V_{DDD}$		–	
SID243	$V_{IH}^{[3]}$	LVTTL input, $V_{DDD} \geq 2.7 V$	2.0	–	–		–	
SID244	V_{IL}	LVTTL input, $V_{DDD} \geq 2.7 V$	–	–	0.8		–	
SID59	V_{OH}	Output voltage high level	$V_{DDD} - 0.6$	–	–		$I_{OH} = 4 \text{ mA at } 3 V V_{DDD}$	
SID60	V_{OH}	Output voltage high level	$V_{DDD} - 0.5$	–	–		$I_{OH} = 1 \text{ mA at } 3 V V_{DDD}$	
SID61	V_{OL}	Output voltage low level	–	–	0.6		$I_{OL} = 4 \text{ mA at } 1.8 V V_{DDD}$	
SID62	V_{OL}	Output voltage low level	–	–	0.6		$I_{OL} = 10 \text{ mA at } 3 V V_{DDD}$	
SID62A	V_{OL}	Output voltage low level	–	–	0.4		$I_{OL} = 3 \text{ mA at } 3 V V_{DDD}$	
SID63	R_{PULLUP}	Pull-up resistor	3.5	5.6	8.5		k Ω	–
SID64	$R_{PULLDOWN}$	Pull-down resistor	3.5	5.6	8.5			–
SID65	I_{IL}	Input leakage current (absolute value)	–	–	2	nA	25 °C, $V_{DDD} = 3.0 V$	
SID66	C_{IN}	Input capacitance	–	–	7	pF	–	
SID67 ^[4]	V_{HYSTTL}	Input hysteresis LVTTL	25	40	–	mV	$V_{DDD} \geq 2.7 V$	
SID68 ^[4]	$V_{HYSCMOS}$	Input hysteresis CMOS	$0.05 \times V_{DDD}$	–	–		$V_{DD} < 4.5 V$	
SID68A ^[4]	$V_{HYSCMOS5V5}$	Input hysteresis CMOS	200	–	–		$V_{DD} > 4.5 V$	
SID69 ^[4]	I_{DIODE}	Current through protection diode to V_{DD}/V_{SS}	–	–	100	μA	–	
SID69A ^[4]	I_{TOT_GPIO}	Maximum total source or sink chip current	–	–	200	mA	–	

Table 6. GPIO AC Specifications

(Guaranteed by Characterization)

Spec ID#	Parameter	Description	Min	Typ	Max	Units	Details/ Conditions
SID70	T_{RISEF}	Rise time in fast strong mode	2	–	12	ns	3.3 V V_{DDD} , Load = 25 pF
SID71	T_{FALLF}	Fall time in fast strong mode	2	–	12		3.3 V V_{DDD} , Load = 25 pF
SID72	T_{RISES}	Rise time in slow strong mode	10	–	60	–	3.3 V V_{DDD} , Load = 25 pF
SID73	T_{FALLS}	Fall time in slow strong mode	10	–	60	–	3.3 V V_{DDD} , Load = 25 pF

Notes

- V_{IH} must not exceed $V_{DDD} + 0.2 V$.
- Guaranteed by characterization.

Table 6. GPIO AC Specifications

(Guaranteed by Characterization) (continued)

Spec ID#	Parameter	Description	Min	Typ	Max	Units	Details/ Conditions
SID74	F _{GPIOUT1}	GPIO F _{OUT} ; 3.3 V ≤ V _{DDD} ≤ 5.5 V Fast strong mode	–	–	33	MHz	90/10%, 25 pF load, 60/40 duty cycle
SID75	F _{GPIOUT2}	GPIO F _{OUT} ; 1.71 V ≤ V _{DDD} ≤ 3.3 V Fast strong mode	–	–	16.7		90/10%, 25 pF load, 60/40 duty cycle
SID76	F _{GPIOUT3}	GPIO F _{OUT} ; 3.3 V ≤ V _{DDD} ≤ 5.5 V Slow strong mode	–	–	7		90/10%, 25 pF load, 60/40 duty cycle
SID245	F _{GPIOUT4}	GPIO F _{OUT} ; 1.71 V ≤ V _{DDD} ≤ 3.3 V Slow strong mode.	–	–	3.5		90/10%, 25 pF load, 60/40 duty cycle
SID246	F _{GPIOIN}	GPIO input operating frequency; 1.71 V ≤ V _{DDD} ≤ 5.5 V	–	–	48		90/10% V _{IO}

XRES

Table 7. XRES DC Specifications

Spec ID#	Parameter	Description	Min	Typ	Max	Units	Details/ Conditions
SID77	V _{IH}	Input voltage high threshold	0.7 × V _{DDD}	–	–	V	CMOS Input
SID78	V _{IL}	Input voltage low threshold	–	–	0.3 × V _{DDD}		
SID79	R _{PULLUP}	Pull-up resistor	–	60	–	kΩ	–
SID80	C _{IN}	Input capacitance	–	–	7	pF	–
SID81 ^[5]	V _{HYSXRES}	Input voltage hysteresis	–	100	–	mV	Typical hysteresis is 200 mV for V _{DD} > 4.5 V
SID82	I _{DIODE}	Current through protection diode to V _{DD} /V _{SS}	–	–	100	μA	

Table 8. XRES AC Specifications

Spec ID#	Parameter	Description	Min	Typ	Max	Units	Details/ Conditions
SID83 ^[5]	T _{RESETWIDTH}	Reset pulse width	1	–	–	μs	–
BID194 ^[5]	T _{RESETWAKE}	Wake-up time from reset release	–	–	2.7	ms	–

Note

5. Guaranteed by characterization.

Analog Peripherals

Table 9. Comparator DC Specifications

Spec ID#	Parameter	Description	Min	Typ	Max	Units	Details/ Conditions
SID84	V _{OFFSET1}	Input offset voltage, Factory trim	–	–	±10	mV	–
SID85	V _{OFFSET2}	Input offset voltage, Custom trim	–	–	±4		–
SID86	V _{HYST}	Hysteresis when enabled	–	10	35		–
SID87	V _{ICM1}	Input common mode voltage in normal mode	0	–	V _{DDD} -0.1	V	Modes 1 and 2
SID247	V _{ICM2}	Input common mode voltage in low power mode	0	–	V _{DDD}		–
SID247A	V _{ICM3}	Input common mode voltage in ultra low power mode	0	–	V _{DDD} -1.15		V _{DDD} ≥ 2.2 V at -40 °C
SID88	C _{MRR}	Common mode rejection ratio	50	–	–	dB	V _{DDD} ≥ 2.7V
SID88A	C _{MRR}	Common mode rejection ratio	42	–	–		V _{DDD} ≤ 2.7V
SID89	I _{CMP1}	Block current, normal mode	–	–	400	μA	–
SID248	I _{CMP2}	Block current, low power mode	–	–	100		–
SID259	I _{CMP3}	Block current in ultra low-power mode	–	6	28		V _{DDD} ≥ 2.2 V at -40 °C
SID90	Z _{CMP}	DC Input impedance of comparator	35	–	–	MΩ	–

Table 10. Comparator AC Specifications

Spec ID#	Parameter	Description	Min	Typ	Max	Units	Details/ Conditions
SID91	TRESP1	Response time, normal mode, 50 mV overdrive	–	38	110	ns	–
SID258	TRESP2	Response time, low power mode, 50 mV overdrive	–	70	200		–
SID92	TRESP3	Response time, ultra-low power mode, 200 mV overdrive	–	2.3	15	μs	V _{DDD} ≥ 2.2 V at -40 °C

CSD

Table 11. CSD and IDAC Specifications

SPEC ID#	Parameter	Description	Min	Typ	Max	Units	Details / Conditions
SYS.PER#3	VDD_RIPPLE	Max allowed ripple on power supply, DC to 10 MHz	–	–	±50	mV	$V_{DD} > 2\text{ V}$ (with ripple), 25°C T_A , Sensitivity = 0.1 pF
SYS.PER#16	VDD_RIPPLE_1.8	Max allowed ripple on power supply, DC to 10 MHz	–	–	±25	mV	$V_{DD} > 1.75\text{V}$ (with ripple), 25°C T_A , Parasitic Capacitance (C_p) < 20 pF, Sensitivity ≥ 0.4 pF
SID.CSD.BLK	ICSD	Maximum block current	–	–	4000	μA	Maximum block current for both IDACs in dynamic (switching) mode including comparators, buffer, and reference generator.
SID.CSD#15	V _{REF}	Voltage reference for CSD and Comparator	0.6	1.2	$V_{DDA} - 0.6$	V	$V_{DDA} - 0.06$ or 4.4, whichever is lower
SID.CSD#15A	VREF_EXT	External Voltage reference for CSD and Comparator	0.6		$V_{DDA} - 0.6$	V	$V_{DDA} - 0.06$ or 4.4, whichever is lower
SID.CSD#16	IDAC1IDD	IDAC1 (7-bits) block current	–	–	1750	μA	
SID.CSD#17	IDAC2IDD	IDAC2 (7-bits) block current	–	–	1750	μA	
SID308	VCSD	Voltage range of operation	1.71	–	5.5	V	1.8 V ±5% or 1.8 V to 5.5 V
SID308A	VCOMPIDAC	Voltage compliance range of IDAC	0.6	–	$V_{DDA} - 0.6$	V	$V_{DDA} - 0.06$ or 4.4, whichever is lower
SID309	IDAC1DNL	DNL	–1	–	1	LSB	
SID310	IDAC1INL	INL	–2	–	2	LSB	INL is ±5.5 LSB for $V_{DDA} < 2\text{ V}$
SID311	IDAC2DNL	DNL	–1	–	1	LSB	
SID312	IDAC2INL	INL	–2	–	2	LSB	INL is ±5.5 LSB for $V_{DDA} < 2\text{ V}$
SID313	SNR	Ratio of counts of finger to noise. Guaranteed by characterization	5	–	–	Ratio	Capacitance range of 5 to 35 pF, 0.1-pF sensitivity. All use cases. $V_{DDA} > 2\text{ V}$.
SID314	IDAC1CRT1	Output current of IDAC1 (7 bits) in low range	4.2	–	5.4	μA	LSB = 37.5-nA typ.
SID314A	IDAC1CRT2	Output current of IDAC1(7 bits) in medium range	34	–	41	μA	LSB = 300-nA typ.
SID314B	IDAC1CRT3	Output current of IDAC1(7 bits) in high range	275	–	330	μA	LSB = 2.4-μA typ.
SID314C	IDAC1CRT12	Output current of IDAC1 (7 bits) in low range, 2X mode	8	–	10.5	μA	LSB = 75-nA typ.
SID314D	IDAC1CRT22	Output current of IDAC1(7 bits) in medium range, 2X mode	69	–	82	μA	LSB = 600-nA typ.
SID314E	IDAC1CRT32	Output current of IDAC1(7 bits) in high range, 2X mode	540	–	660	μA	LSB = 4.8-μA typ.
SID315	IDAC2CRT1	Output current of IDAC2 (7 bits) in low range	4.2	–	5.4	μA	LSB = 37.5-nA typ.
SID315A	IDAC2CRT2	Output current of IDAC2 (7 bits) in medium range	34	–	41	μA	LSB = 300-nA typ.
SID315B	IDAC2CRT3	Output current of IDAC2 (7 bits) in high range	275	–	330	μA	LSB = 2.4-μA typ.
SID315C	IDAC2CRT12	Output current of IDAC2 (7 bits) in low range, 2X mode	8	–	10.5	μA	LSB = 75-nA typ.
SID315D	IDAC2CRT22	Output current of IDAC2(7 bits) in medium range, 2X mode	69	–	82	μA	LSB = 600-nA typ.
SID315E	IDAC2CRT32	Output current of IDAC2(7 bits) in high range, 2X mode	540	–	660	μA	LSB = 4.8-μA typ.
SID315F	IDAC3CRT13	Output current of IDAC in 8-bit mode in low range	8	–	10.5	μA	LSB = 37.5-nA typ.

Table 11. CSD and IDAC Specifications (continued)

SPEC ID#	Parameter	Description	Min	Typ	Max	Units	Details / Conditions
SID315G	IDAC3CRT23	Output current of IDAC in 8-bit mode in medium range	69	–	82	μA	LSB = 300-nA typ.
SID315H	IDAC3CRT33	Output current of IDAC in 8-bit mode in high range	540	–	660	μA	LSB = 2.4-μA typ.
SID320	IDACOFFSET	All zeroes input	–	–	1	LSB	Polarity set by Source or Sink. Offset is 2 LSBs for 37.5 nA/LSB mode
SID321	IDACGAIN	Full-scale error less offset	–	–	±10	%	
SID322	IDACMISMATCH1	Mismatch between IDAC1 and IDAC2 in Low mode	–	–	9.2	LSB	LSB = 37.5-nA typ.
SID322A	IDACMISMATCH2	Mismatch between IDAC1 and IDAC2 in Medium mode	–	–	5.6	LSB	LSB = 300-nA typ.
SID322B	IDACMISMATCH3	Mismatch between IDAC1 and IDAC2 in High mode	–	–	6.8	LSB	LSB = 2.4-μA typ.
SID323	IDACSET8	Settling time to 0.5 LSB for 8-bit IDAC	–	–	10	μs	Full-scale transition. No external load.
SID324	IDACSET7	Settling time to 0.5 LSB for 7-bit IDAC	–	–	10	μs	Full-scale transition. No external load.
SID325	CMOD	External modulator capacitor.	–	2.2	–	nF	5-V rating, X7R or NP0 cap.

Table 12. 10-bit CapSense ADC Specifications

Spec ID#	Parameter	Description	Min	Typ	Max	Units	Details/Conditions
SIDA94	A_RES	Resolution	–	–	10	bits	Auto-zeroing is required every millisecond
SIDA95	A_CHNLS_S	Number of channels - single ended	–	–	16		Defined by AMUX Bus.
SIDA97	A-MONO	Monotonicity	–	–	–	Yes	
SIDA98	A_GAINERR	Gain error	–	–	±2	%	In V _{REF} (2.4 V) mode with V _{DDA} bypass capacitance of 10 μF
SIDA99	A_OFFSET	Input offset voltage	–	–	3	mV	In V _{REF} (2.4 V) mode with V _{DDA} bypass capacitance of 10 μF
SIDA100	A_ISAR	Current consumption	–	–	0.25	mA	
SIDA101	A_VINS	Input voltage range - single ended	V _{SSA}	–	V _{DDA}	V	
SIDA103	A_INRES	Input resistance	–	2.2	–	KΩ	
SIDA104	A_INCAP	Input capacitance	–	20	–	pF	
SIDA106	A_PSR	Power supply rejection ratio	–	60	–	dB	In V _{REF} (2.4 V) mode with V _{DDA} bypass capacitance of 10 μF
SIDA107	A_TACQ	Sample acquisition time	–	1	–	μs	
SIDA108	A_CONV8	Conversion time for 8-bit resolution at conversion rate = F _{clk} /(2 ^N)). Clock frequency = 48 MHz.	–	–	21.3	μs	Does not include acquisition time. Equivalent to 44.8 ksp/s including acquisition time.
SIDA108A	A_CONV10	Conversion time for 10-bit resolution at conversion rate = F _{clk} /(2 ^N)). Clock frequency = 48 MHz.	–	–	85.3	μs	Does not include acquisition time. Equivalent to 11.6 ksp/s including acquisition time.

Table 12. 10-bit CapSense ADC Specifications (continued)

Spec ID#	Parameter	Description	Min	Typ	Max	Units	Details/Conditions
SIDA109	A_SND	Signal-to-noise and Distortion ratio (SINAD)	–	61	–	dB	With 10-Hz input sine wave, external 2.4-V reference, V _{REF} (2.4 V) mode
SIDA110	A_BW	Input bandwidth without aliasing	–	–	22.4	kHz	8-bit resolution
SIDA111	A_INL	Integral Non Linearity. 1 ksp	–	–	2	LSB	V _{REF} = 2.4 V or greater
SIDA112	A_DNL	Differential Non Linearity. 1 ksp	–	–	1	LSB	

Digital Peripherals
Timer Counter Pulse-Width Modulator (TCPWM)
Table 13. TCPWM Specifications

Spec ID	Parameter	Description	Min	Typ	Max	Units	Details/Conditions
SID.TCPWM.1	ITCPWM1	Block current consumption at 3 MHz	–	–	45	μA	All modes (TCPWM)
SID.TCPWM.2	ITCPWM2	Block current consumption at 12 MHz	–	–	155		All modes (TCPWM)
SID.TCPWM.2A	ITCPWM3	Block current consumption at 48 MHz	–	–	650		All modes (TCPWM)
SID.TCPWM.3	TCPWM _{FREQ}	Operating frequency	–	–	F _c	MHz	F _c max = CLK_SYS Maximum = 48 MHz
SID.TCPWM.4	TPWM _{ENEXT}	Input trigger pulse width	2/F _c	–	–	ns	For all trigger events ^[6]
SID.TCPWM.5	TPWM _{EXT}	Output trigger pulse widths	2/F _c	–	–		Minimum possible width of Overflow, Underflow, and CC (Counter equals Compare value) outputs
SID.TCPWM.5A	TC _{RES}	Resolution of counter	1/F _c	–	–		Minimum time between successive counts
SID.TCPWM.5B	PWM _{RES}	PWM resolution	1/F _c	–	–		Minimum pulse width of PWM Output
SID.TCPWM.5C	Q _{RES}	Quadrature inputs resolution	1/F _c	–	–		Minimum pulse width between Quadrature phase inputs

Note

6. Trigger events can be Stop, Start, Reload, Count, Capture, or Kill depending on which mode of operation is selected.

I²C

Table 14. Fixed I²C DC Specifications^[7]

Spec ID	Parameter	Description	Min	Typ	Max	Units	Details/Conditions
SID149	I _{I2C1}	Block current consumption at 100 kHz	–	–	50	μA	–
SID150	I _{I2C2}	Block current consumption at 400 kHz	–	–	135		–
SID151	I _{I2C3}	Block current consumption at 1 Mbps	–	–	310		–
SID152	I _{I2C4}	I ² C enabled in Deep Sleep mode	–	–	1.4		

Table 15. Fixed I²C AC Specifications^[7]

Spec ID	Parameter	Description	Min	Typ	Max	Units	Details/Conditions
SID153	F _{I2C1}	Bit rate	–	–	1	Msp/s	–

Table 16. SPI DC Specifications^[7]

Spec ID	Parameter	Description	Min	Typ	Max	Units	Details/Conditions
SID163	ISPI1	Block current consumption at 1 Mbps	–	–	360	μA	–
SID164	ISPI2	Block current consumption at 4 Mbps	–	–	560		–
SID165	ISPI3	Block current consumption at 8 Mbps	–	–	600		–

Table 17. SPI AC Specifications^[7]

Spec ID	Parameter	Description	Min	Typ	Max	Units	Details/Conditions
SID166	FSPI	SPI operating frequency (Master; 6X Oversampling)	–	–	8	MHz	
Fixed SPI Master Mode AC Specifications							
SID167	TDMO	MOSI Valid after SClk driving edge	–	–	15	ns	–
SID168	TDSI	MISO Valid before SClk capturing edge	20	–	–		Full clock, late MISO sampling
SID169	THMO	Previous MOSI data hold time	0	–	–		Referred to Slave capturing edge
Fixed SPI Slave Mode AC Specifications							
SID170	TDMI	MOSI Valid before SClk Capturing edge	40	–	–	ns	–
SID171	TDSO	MISO Valid after SClk driving edge	–	–	42 + 3*T _{cpu}		T _{CPU} = 1/F _{CPU}
SID171A	TDSO_EXT	MISO Valid after SClk driving edge in Ext. Clk mode	–	–	48		–
SID172	THSO	Previous MISO data hold time	0	–	–		–
SID172A	TSSELSSCK	SSEL Valid to first SCK Valid edge	–	–	100	ns	–

Note

7. Guaranteed by characterization.

Table 18. UART DC Specifications^[8]

Spec ID	Parameter	Description	Min	Typ	Max	Units	Details/Conditions
SID160	I _{UART1}	Block current consumption at 100 Kbps	–	–	55	μA	–
SID161	I _{UART2}	Block current consumption at 1000 Kbps	–	–	312	μA	–

Table 19. UART AC Specifications^[8]

Spec ID	Parameter	Description	Min	Typ	Max	Units	Details/Conditions
SID162	F _{UART}	Bit rate	–	–	1	Mbps	–

Table 20. LCD Direct Drive DC Specifications^[8]

Spec ID	Parameter	Description	Min	Typ	Max	Units	Details/Conditions
SID154	I _{LCDLOW}	Operating current in low power mode	–	5	–	μA	16 × 4 small segment disp. at 50 Hz
SID155	C _{LCDCAP}	LCD capacitance per segment/common driver	–	500	5000	pF	–
SID156	LCD _{OFFSET}	Long-term segment offset	–	20	–	mV	–
SID157	I _{LCDOP1}	LCD system operating current V _{bias} = 5 V	–	2	–	mA	32 × 4 segments. 50 Hz. 25 °C
SID158	I _{LCDOP2}	LCD system operating current V _{bias} = 3.3 V	–	2	–		32 × 4 segments. 50 Hz. 25 °C

Table 21. LCD Direct Drive AC Specifications^[8]

Spec ID	Parameter	Description	Min	Typ	Max	Units	Details/Conditions
SID159	F _{LCD}	LCD frame rate	10	50	150	Hz	–

Note

8. Guaranteed by characterization.

Memory

Table 22. Flash DC Specifications

Spec ID	Parameter	Description	Min	Typ	Max	Units	Details/Conditions
SID173	V _{PE}	Erase and program voltage	1.71	–	5.5	V	–

Table 23. Flash AC Specifications

Spec ID	Parameter	Description	Min	Typ	Max	Units	Details/Conditions
SID174	T _{ROWWRITE} ^[9]	Row (block) write time (erase and program)	–	–	20	ms	Row (block) = 128 bytes
SID175	T _{ROWERASE} ^[9]	Row erase time	–	–	16		–
SID176	T _{ROWPROGRAM} ^[9]	Row program time after erase	–	–	4		–
SID178	T _{BULKERASE} ^[9]	Bulk erase time (32 KB)	–	–	35		–
SID180 ^[10]	T _{DEVPROG} ^[9]	Total device program time	–	–	7	Seconds	–
SID181 ^[10]	F _{END}	Flash endurance	100 K	–	–	Cycles	–
SID182 ^[10]	F _{RET}	Flash retention. T _A ≤ 55 °C, 100 K P/E cycles	20	–	–	Years	–
SID182A ^[10]	–	Flash retention. T _A ≤ 85 °C, 10 K P/E cycles	10	–	–		–
SID256	TWS48	Number of Wait states at 48 MHz	2	–	–		CPU execution from Flash
SID257	TWS24	Number of Wait states at 24 MHz	1	–	–		CPU execution from Flash

System Resources

Power-on Reset (POR)

Table 24. Power On Reset (PRES)

Spec ID	Parameter	Description	Min	Typ	Max	Units	Details/Conditions
SID.CLK#6	SR_POWER_UP	Power supply slew rate	1	–	67	V/ms	At power-up
SID185 ^[10]	V _{RISEIPOR}	Rising trip voltage	0.80	–	1.5	V	–
SID186 ^[10]	V _{FALLIPOR}	Falling trip voltage	0.70	–	1.4		–

Table 25. Brown-out Detect (BOD) for V_{CCD}

Spec ID	Parameter	Description	Min	Typ	Max	Units	Details/Conditions
SID190 ^[10]	V _{FALLPPOR}	BOD trip voltage in active and sleep modes	1.48	–	1.62	V	–
SID192 ^[10]	V _{FALLDPSLP}	BOD trip voltage in Deep Sleep	1.11	–	1.5		–

Notes

9. It can take as much as 20 milliseconds to write to Flash. During this time the device should not be Reset, or Flash operations will be interrupted and cannot be relied on to have completed. Reset sources include the XRES pin, software resets, CPU lockup states and privilege violations, improper power supply levels, and watchdogs. Make certain that these are not inadvertently activated.

10. Guaranteed by characterization.

SWD Interface

Table 26. SWD Interface Specifications

Spec ID	Parameter	Description	Min	Typ	Max	Units	Details/Conditions
SID213	F_SWDCLK1	$3.3\text{ V} \leq V_{DD} \leq 5.5\text{ V}$	–	–	14	MHz	SWDCLK \leq 1/3 CPU clock frequency
SID214	F_SWDCLK2	$1.71\text{ V} \leq V_{DD} \leq 3.3\text{ V}$	–	–	7		SWDCLK \leq 1/3 CPU clock frequency
SID215 ^[11]	T_SWDI_SETUP	$T = 1/f\text{ SWDCLK}$	$0.25 \cdot T$	–	–	ns	–
SID216 ^[11]	T_SWDI_HOLD	$T = 1/f\text{ SWDCLK}$	$0.25 \cdot T$	–	–		–
SID217 ^[11]	T_SWDO_VALID	$T = 1/f\text{ SWDCLK}$	–	–	$0.5 \cdot T$		–
SID217A ^[11]	T_SWDO_HOLD	$T = 1/f\text{ SWDCLK}$	1	–	–		–

Internal Main Oscillator

Table 27. IMO DC Specifications

(Guaranteed by Design)

Spec ID	Parameter	Description	Min	Typ	Max	Units	Details/Conditions
SID218	I _{IMO1}	IMO operating current at 48 MHz	–	–	250	μA	–
SID219	I _{IMO2}	IMO operating current at 24 MHz	–	–	180	μA	–

Table 28. IMO AC Specifications

Spec ID	Parameter	Description	Min	Typ	Max	Units	Details/Conditions
SID223	F _{IMOTOL1}	Frequency variation at 24, 32, and 48 MHz (trimmed)	–	–	±2	%	
SID226	T _{STARTIMO}	IMO startup time	–	–	7	μs	–
SID228	T _{JITRMSIMO2}	RMS jitter at 24 MHz	–	145	–	ps	–

Internal Low-Speed Oscillator

Table 29. ILO DC Specifications

(Guaranteed by Design)

Spec ID	Parameter	Description	Min	Typ	Max	Units	Details/Conditions
SID231 ^[11]	I _{ILO1}	ILO operating current	–	0.3	1.05	μA	–

Table 30. ILO AC Specifications

Spec ID	Parameter	Description	Min	Typ	Max	Units	Details/Conditions
SID234 ^[11]	T _{STARTILO1}	ILO startup time	–	–	2	ms	–
SID236 ^[11]	T _{ILODUTY}	ILO duty cycle	40	50	60	%	–
SID237	F _{ILOTRIM1}	ILO frequency range	20	40	80	kHz	–

Note

11. Guaranteed by characterization.

Table 31. Watch Crystal Oscillator (WCO) Specifications

Spec ID#	Parameter	Description	Min	Typ	Max	Units	Details / Conditions
SID398	FWCO	Crystal Frequency	–	32.768	–	kHz	
SID399	FTOL	Frequency tolerance	–	50	250	ppm	With 20-ppm crystal
SID400	ESR	Equivalent series resistance	–	50	–	kΩ	
SID401	PD	Drive Level	–	–	1	μW	
SID402	TSTART	Startup time	–	–	500	ms	
SID403	CL	Crystal Load Capacitance	6	–	12.5	pF	
SID404	C0	Crystal Shunt Capacitance	–	1.35	–	pF	
SID405	IWCO1	Operating Current (high power mode)	–	–	8	uA	
SID406	IWCO2	Operating Current (low power mode)	–	–	1	uA	

Table 32. External Clock Specifications

Spec ID	Parameter	Description	Min	Typ	Max	Units	Details/Conditions
SID305 ^[12]	ExtClkFreq	External clock input frequency	0	–	48	MHz	–
SID306 ^[12]	ExtClkDuty	Duty cycle; measured at $V_{DD/2}$	45	–	55	%	–

Table 33. Block Specs

Spec ID	Parameter	Description	Min	Typ	Max	Units	Details/Conditions
SID262 ^[12]	T _{CLKSWITCH}	System clock source switching time	3	–	4	Periods	–

Table 34. Smart I/O Pass-through Time (Delay in Bypass Mode)

Spec ID#	Parameter	Description	Min	Typ	Max	Units	Details / Conditions
SID252	PRG_BYPASS	Max delay added by Smart I/O in bypass mode	–	–	1.6	ns	

Note

12. Guaranteed by characterization.

Ordering Information

The PSoC 4000S part numbers and features are listed in the following table.

Table 35. PSoC 4000S Ordering Information

Category	MPN	Features											Package					
		Max CPU Speed (MHz)	Flash (KB)	SRAM (KB)	Opamp (CTBm)	CapSense	10-bit CSD ADC	12-bit SAR ADC	LP Comparators	TCPWM Blocks	SCB Blocks	Smart I/Os	GPIO	WLCSP (0.35-mm pitch)	24-Pin QFN	32-Pin QFN	40-Pin QFN	48-Pin TQFP
4024	CY8C4024FNI-S402	24	16	2	0	0	1	0	2	5	2	8	21	✓				
	CY8C4024LQI-S401	24	16	2	0	0	1	0	2	5	2	8	19		✓			
	CY8C4024LQI-S402	24	16	2	0	0	1	0	2	5	2	16	27			✓		
	CY8C4024LQI-S403	24	16	2	0	0	1	0	2	5	2	16	34				✓	
	CY8C4024AZI-S403	24	16	2	0	0	1	0	2	5	2	16	36					✓
	CY8C4024FNI-S412	24	16	2	0	1	1	0	2	5	2	8	21	✓				
	CY8C4024LQI-S411	24	16	2	0	1	1	0	2	5	2	8	19		✓			
	CY8C4024LQI-S412	24	16	2	0	1	1	0	2	5	2	16	27			✓		
	CY8C4024LQI-S413	24	16	2	0	1	1	0	2	5	2	16	34				✓	
4025	CY8C4025FNI-S402	24	32	4	0	0	1	0	2	5	2	8	21	✓				
	CY8C4025LQI-S401	24	32	4	0	0	1	0	2	5	2	8	19		✓			
	CY8C4025LQI-S402	24	32	4	0	0	1	0	2	5	2	16	27			✓		
	CY8C4025AZI-S403	24	32	4	0	0	1	0	2	5	2	16	36					✓
	CY8C4025FNI-S412	24	32	4	0	1	1	0	2	5	2	8	21	✓				
	CY8C4025LQI-S411	24	32	4	0	1	1	0	2	5	2	8	19		✓			
	CY8C4025LQI-S412	24	32	4	0	1	1	0	2	5	2	16	27			✓		
4045	CY8C4045FNI-S412	48	32	4	0	1	1	0	2	5	2	8	21	✓				
	CY8C4045LQI-S411	48	32	4	0	1	1	0	2	5	2	8	19		✓			
	CY8C4045LQI-S412	48	32	4	0	1	1	0	2	5	2	16	27			✓		
	CY8C4045AZI-S413	48	32	4	0	1	1	0	2	5	2	16	36					✓

The nomenclature used in the preceding table is based on the following part numbering convention:

Field	Description	Values	Meaning
CY8C	Cypress Prefix		
4	Architecture	4	PSoC 4
A	Family	0	4000 Family
B	CPU Speed	2	24 MHz
		4	48 MHz