



Chipsmall Limited consists of a professional team with an average of over 10 year of expertise in the distribution of electronic components. Based in Hongkong, we have already established firm and mutual-benefit business relationships with customers from,Europe,America and south Asia,supplying obsolete and hard-to-find components to meet their specific needs.

With the principle of “Quality Parts,Customers Priority,Honest Operation,and Considerate Service”,our business mainly focus on the distribution of electronic components. Line cards we deal with include Microchip,ALPS,ROHM,Xilinx,Pulse,ON,Everlight and Freescale. Main products comprise IC,Modules,Potentiometer,IC Socket,Relay,Connector.Our parts cover such applications as commercial,industrial, and automotives areas.

We are looking forward to setting up business relationship with you and hope to provide you with the best service and solution. Let us make a better world for our industry!



Contact us

Tel: +86-755-8981 8866 Fax: +86-755-8427 6832

Email & Skype: info@chipsmall.com Web: www.chipsmall.com

Address: A1208, Overseas Decoration Building, #122 Zhenhua RD., Futian, Shenzhen, China



Features

- Zero insertion loss
- Low distortion transformer signal coupling (0.01% max)
- Complete ring detector circuit
- Low power hookswitch
- Electronic inductor/gyrator circuit
- Solid state surge protection
- Transient protection zeners
- Complete hybrid circuit (2-4 wire converter) included
- Compatible with all modem chip sets
- V.32 bis/V.34 compatible

Description

Clare's Cybergate™ CYG2218 DAA module provides a complete telephone line interface circuit featuring 0dB insertion loss. It includes a 2-4 wire converter for transmit and receive signal separation in a small 1.07" x 1.07" x 0.4" package. The module provides a fast and cost effective solution for designs that require an interface to the telephone line. The module is designed to meet FCC part 68 requirements thus providing a low risk design solution.

Approvals

- UL recognized file #: E174201

Applications

- Modems
- Fax machines
- Remote data acquisition
- Security systems
- Voice mail systems
- PC motherboard
- Computer telephony
- Process control
- Medical
- PBX
- Direct broadcast satellite

Ordering Information

Part #	Description
CYG2218	DAA Module (18/Tube)

Block Diagram

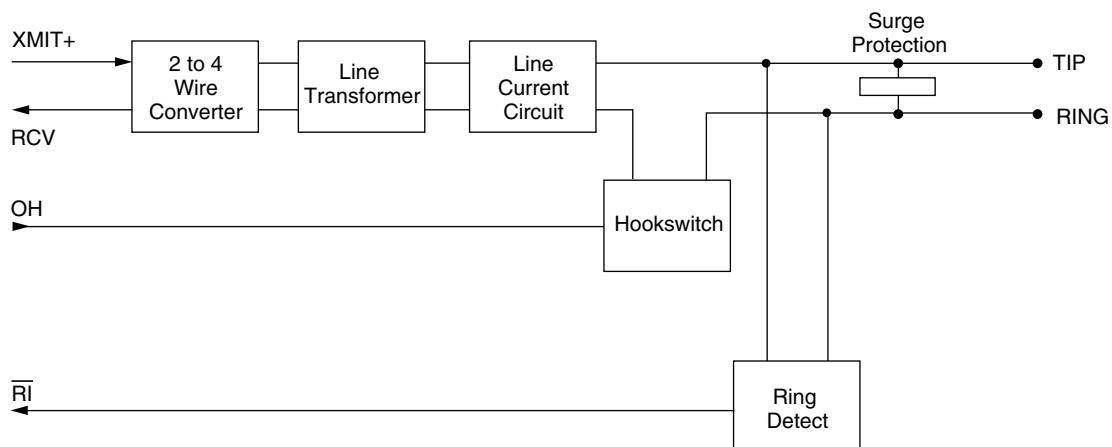

Handling and Assembly Recommendations

The CYG2218 products are not hermetically sealed and should not be exposed to any liquid-based rinsing processes. Clare recommends two (2) approaches. The modem should either use a no clean soldering flux that would mostly evaporate during the normal wave soldering processes, or be soldered by hand after the rest of the card is wave soldered.



CYG2218

Absolute Maximum Ratings (@ 25° C)

Parameter	Min	Typ	Max	Units
Isolation Voltage	-	-	1000	V_{RMS}
Operational Temperature	0	-	70	°C
Storage Temperature	0	-	100	°C
Relative Humidity (Non-Condensing)	10	-	85	%
Soldering Temperature	-	-	260	°C
Tip/Ring Load Current (continuous)	-	-	120	mA
Hookswitch LED Drive Current	-	-	50	mA
Hookswitch LED Reverse Voltage	-	-	5	V
Ring Detect Phototransistor Voltage V_{CC}	-	-	20	V

¹ Derate Linearly 1.33 mw / oC

² Derate Linearly 3.67 mw / oC

Absolute Maximum Ratings are stress ratings. Stresses in excess of these ratings can cause permanent damage to the device. Functional operation of the device at these or any other conditions beyond those indicated in the operational sections of this data sheet is not implied. Exposure of the device to the absolute maximum ratings for an extended period may degrade the device and effect its reliability.

Electrical Characteristics

Parameter	Conditions	Min	Typ	Max	Units
DC Electrical Characteristics					
On-Hook Impedance 2,1 (R,T) per FCC 68.312	@100V V_{DC} across pins 1,2	10	-	-	MΩ
Off-Hook Line Leakage Current 2,1 (R,T) per FCC 68.312	@100V V_{DC} across pins 1,2	-	-	10	μA
Power Supply Current @ V_{CC}	$V_{CC}=5V$	4	5	6	mA
Hookswitch Control Current @ (OH)	@ $V_{OH}=2.4V$	3.5	4.1	5.0	mA
	@ $V_{OH}=5.0V$	11.8	12.4	13	mA
Hookswitch Control Voltage	Off-Hook	2.0	3.0	20	V
	On-Hook	-	0.2	0.5	V
AC Signal Path Electrical Characteristics					
Return Loss	600Ω, 1800Hz	39	40	-	dB
Insertion Loss	600Ω, 1800Hz				
	Transmit Test Circuit 1	-1.0	0	+1.0	dB
Receive Test Circuit 2	-1.0	0	+1.0	dB	
Frequency Response	300-3500Hz	-0.25	-	+0.25	dB
Longitudinal Balance	On-Hook	60	-	-	dB
	Off-Hook	40	-	-	dB
Transhybrid Loss	600Ω, 1800Hz	-	-32	-10	dB
Total Harmonic Distortion	600Ω, 1800Hz	-	-80	-	dB
DC Loop Current	-	20	-	120	mA
Ring Detection Circuit Characteristics					
Ring Voltage Detection Range	-	20	-	150	V_{RMS}
Ring Frequency Detection Range	-	15	-	70	Hz
Ringer Equivalence Number	-	-	0.8B	-	-
RING (Pin 5) Output Voltage (Pulsed) Logic '0', Ring present Logic '1', Ring not present	$V_{CC}=+5V$				
		-	-	0.8	V
		-	-	V_{CC}	V
Surge and Isolation Characteristics					
Surge Protection Voltage Tip and Ring (Pins 1,2)	-	-	-	300	V
Isolation Voltage (Pins 18,17,16,15,14,5,4,to1,2)	Per FCC 68.302	1000	-	-	V_{RMS}

Test Circuits

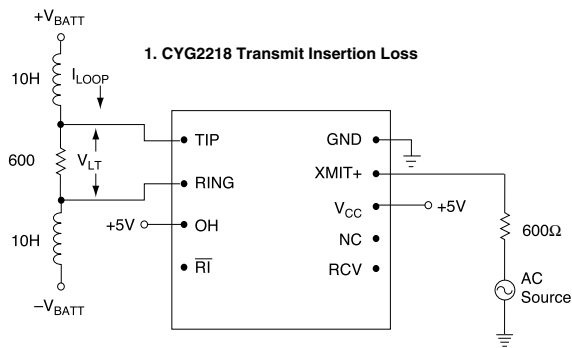

$$\text{Transmit Insertion Loss} = G_{TR} = 20 \text{Log} \frac{V_{LT}}{V_T}$$

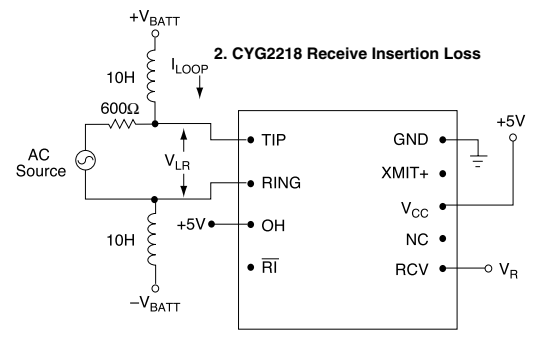

$$\text{Receive Insertion Loss} = G_{RC} = 20 \text{Log} \frac{V_R}{V_{LR}}$$

Package Pinout

CYG2218

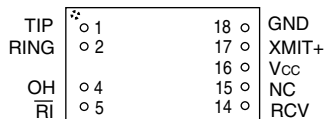

Top View

CYG2218 Pinouts & Definitions

PIN#	Name	Function
1	TIP	Connection to telephone line Tip connected through an external fuse.
2	RING	Connection to telephone line Ring conductor.
4	OH	Driving this pin high asserts the off-hook condition. The hookswitch LED is current limited by an internal 300Ω resistor.
5	RI	Active LOW indicates an incoming ring signal. This is pulsed LOW by the AC ring signal and is not a steady state LOW during ringing.
14	RCV	Provides the analog output signal from the 2-4 wire converter of the CYG2218. RCV uses a 2.5 volt reference signal and therefore must be capacitively coupled to host equipment which uses a ground reference.
15	NC	No connection.
16	V _{CC}	Provides power to the CYG2218. Typically +5V, V _{CC} should not exceed 20V.
17	XMIT+	Provides the analog input signal from the 2-4 wire converter of the CYG2218. XMIT+ uses a 2.5 volt reference signal and therefore must be capacitively coupled to host equipment which uses a ground reference.
18	GND	Connection to host system ground.



CLARE

For additional information please visit our website at: www.clare.com

Clare, Inc. makes no representations or warranties with respect to the accuracy or completeness of the contents of this publication and reserves the right to make changes to specifications and product descriptions at any time without notice. Neither circuit patent licenses nor indemnity are expressed or implied. Except as set forth in Clare's Standard Terms and Conditions of Sale, Clare, Inc. assumes no liability whatsoever, and disclaims any express or implied warranty, relating to its products including, but not limited to, the implied warranty of merchantability, fitness for a particular purpose, or infringement of any intellectual property right.

The products described in this document are not designed, intended, authorized or warranted for use as components in systems intended for surgical implant into the body, or in other applications intended to support or sustain life, or where malfunction of Clare's product may result in direct physical harm, injury, or death to a person or severe property or environmental damage. Clare, Inc. reserves the right to discontinue or make changes to its products at any time without notice.

Specification: DS-CYG2218-R1.0
©Copyright 2002, Clare, Inc.
Cybergate™ is a trademark of Clare, Inc.
All rights reserved. Printed in USA.
3/22/02