



Chipsmall Limited consists of a professional team with an average of over 10 year of expertise in the distribution of electronic components. Based in Hongkong, we have already established firm and mutual-benefit business relationships with customers from,Europe,America and south Asia,supplying obsolete and hard-to-find components to meet their specific needs.

With the principle of "Quality Parts,Customers Priority,Honest Operation,and Considerate Service",our business mainly focus on the distribution of electronic components. Line cards we deal with include Microchip,ALPS,ROHM,Xilinx,Pulse,ON,Everlight and Freescale. Main products comprise IC,Modules,Potentiometer,IC Socket,Relay,Connector.Our parts cover such applications as commercial,industrial, and automotives areas.

We are looking forward to setting up business relationship with you and hope to provide you with the best service and solution. Let us make a better world for our industry!



## Contact us

Tel: +86-755-8981 8866 Fax: +86-755-8427 6832

Email & Skype: info@chipsmall.com Web: www.chipsmall.com

Address: A1208, Overseas Decoration Building, #122 Zhenhua RD., Futian, Shenzhen, China



# Programmable Radio on Chip Low Power

## PROc™ LP Features

- **Single Device, Two Functions**
  - 8-bit Flash based MCU function and 2.4 GHz radio transceiver function in a single device.
- **Flash Based Microcontroller Function**
  - M8C based 8-bit CPU, optimized for Human Interface Devices (HID) applications
  - 256 Bytes of SRAM
  - 8 Kbytes of Flash memory with EEPROM emulation
  - In-System reprogrammable
  - CPU speed up to 12 MHz
  - 16-bit free running timer
  - Low power wakeup timer
  - 12-bit Programmable Interval Timer with interrupts
  - Watchdog timer
- **Industry leading 2.4 GHz Radio Transceiver Function**
  - Operates in the unlicensed worldwide Industrial, Scientific, and Medical (ISM) band (2.4 GHz to 2.483 GHz)
  - DSSS data rates of up to 250 Kbps
  - GFSK data rate of 1 Mbps
  - -97 dBm receive sensitivity
- Programmable output power up to +4 dBm
- Auto Transaction Sequencer (ATS)
- Framing CRC and Auto ACK
- Received Signal Strength Indication (RSSI)
- Automatic Gain Control (AGC)
- **Component Reduction**
  - Integrated 1.8 V boost converter
  - GPIOs that require no external components
  - Operates off a single crystal
- **Flexible I/O**
  - 2 mA source current on all GPIO pins. Configurable 8 mA or 50 mA/pin current sink on designated pins
  - Each GPIO pin supports high impedance inputs, configurable pull up, open drain output, CMOS/TTL inputs, and CMOS output
  - Maskable interrupts on all I/O pins
- **Operating Voltage from 1.8 V to 3.6 V DC**
- **Operating Temperature from 0 to 70 °C**
- **Pb-free 40-pin QFN Package**
- **Advanced Development Tools based on Cypress's PSoC® Tools**

## Logic Block Diagram

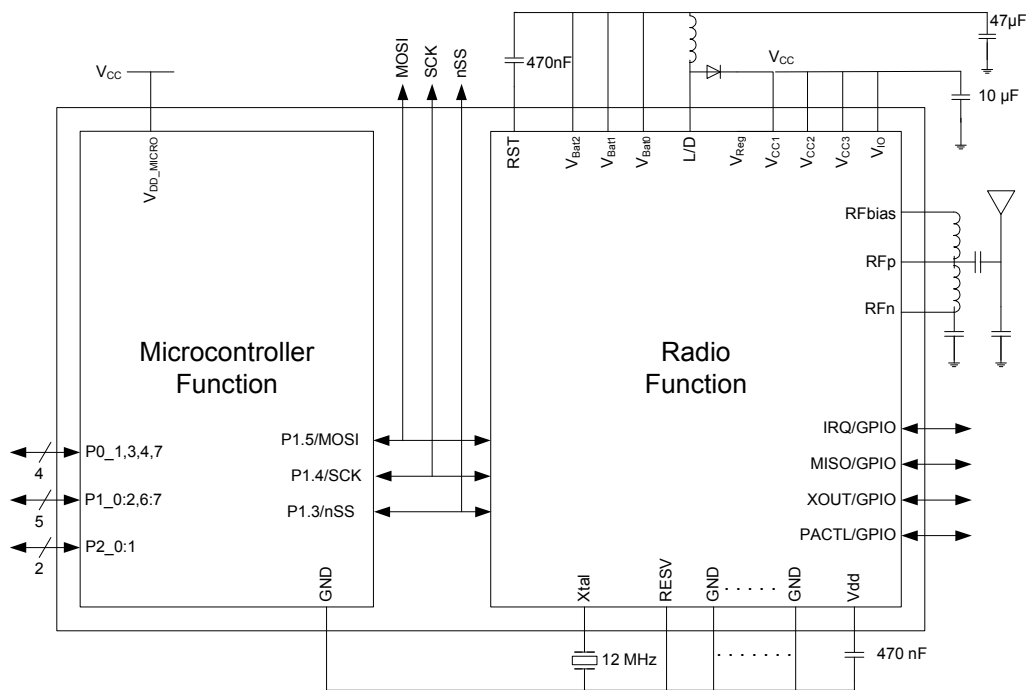

**Contents**

<b>Applications</b> .....	<b>3</b>	Flash Program Memory Organization .....	20
<b>Functional Description</b> .....	<b>3</b>	Data Memory Organization .....	21
<b>Functional Overview</b> .....	<b>3</b>	Flash .....	21
2.4 GHz Radio Function .....	3	SROM .....	21
Data Transmission Modes .....	3	SROM Function Descriptions .....	22
Microcontroller Function .....	3	<b>Clocking</b> .....	<b>25</b>
Backward Compatibility .....	4	SROM Table Read Description .....	26
DDR Mode .....	4	Clock Architecture Description .....	27
SDR Mode .....	5	CPU Clock During Sleep Mode .....	31
<b>Pinouts</b> .....	<b>6</b>	<b>Reset</b> .....	<b>32</b>
<b>Pin Definitions</b> .....	<b>6</b>	Power On Reset .....	33
<b>Functional Block Overview</b> .....	<b>7</b>	Watchdog Timer Reset .....	33
2.4 GHz Radio .....	7	<b>Sleep Mode</b> .....	<b>33</b>
Frequency Synthesizer .....	7	Sleep Sequence .....	33
Baseband and Framer .....	7	Low Power in Sleep Mode .....	34
Packet Buffers and Radio Configuration Registers .....	8	Wakeup Sequence .....	34
Auto Transaction Sequencer (ATS) .....	8	<b>Low Voltage Detect Control</b> .....	<b>36</b>
Interrupts .....	9	POR Compare State .....	37
Clocks .....	9	ECO Trim Register .....	37
GPIO Interface .....	9	<b>General Purpose I/O Ports</b> .....	<b>38</b>
Power On Reset/Low Voltage Detect .....	9	Port Data Registers .....	38
Timers .....	9	GPIO Port Configuration .....	39
Power Management .....	9	GPIO Configurations for Low Power Mode .....	44
Low Noise Amplifier (LNA) and		Serial Peripheral Interface (SPI) .....	45
Received Signal Strength Indication (RSSI) .....	11	SPI Data Register .....	46
Receive Spurious Response .....	11	SPI Configure Register .....	46
<b>SPI Interface</b> .....	<b>11</b>	SPI Interface Pins .....	48
3-Wire SPI Interface .....	11	<b>Timer Registers</b> .....	<b>48</b>
4-Wire SPI Interface .....	11	Registers .....	48
SPI Communication and Transactions .....	12	<b>Interrupt Controller</b> .....	<b>51</b>
SPI I/O Voltage References .....	12	Architectural Description .....	51
SPI Connects to External Devices .....	12	Interrupt Processing .....	52
<b>CPU Architecture</b> .....	<b>13</b>	Interrupt Latency .....	52
<b>CPU Registers</b> .....	<b>14</b>	Interrupt Registers .....	52
Flags Register .....	14	Microcontroller Function Register Summary .....	56
Accumulator Register .....	14	<b>Radio Function Register Summary</b> .....	<b>58</b>
Index Register .....	15	<b>Absolute Maximum Ratings</b> .....	<b>59</b>
Stack Pointer Register .....	15	<b>DC Characteristics</b> .....	<b>59</b>
CPU Program Counter High Register .....	15	<b>AC Characteristics</b> .....	<b>61</b>
CPU Program Counter Low Register .....	15	<b>RF Characteristics</b> .....	<b>65</b>
<b>Addressing Modes</b> .....	<b>16</b>	<b>Ordering Information</b> .....	<b>67</b>
Source Immediate .....	16	Ordering Code Definitions .....	67
Source Direct .....	16	<b>Package Handling</b> .....	<b>68</b>
Source Indexed .....	16	<b>Package Diagram</b> .....	<b>68</b>
Destination Direct .....	16	<b>Acronyms</b> .....	<b>70</b>
Destination Indexed .....	17	<b>Document Conventions</b> .....	<b>70</b>
Destination Direct Source Immediate .....	17	Units of Measure .....	70
Destination Indexed Source Immediate .....	17	<b>Document History Page</b> .....	<b>71</b>
Destination Direct Source Direct .....	17	<b>Sales, Solutions, and Legal Information</b> .....	<b>72</b>
Source Indirect Post Increment .....	18	Worldwide Sales and Design Support .....	72
Destination Indirect Post Increment .....	18	Products .....	72
<b>Instruction Set Summary</b> .....	<b>19</b>	PSoC Solutions .....	72
<b>Memory Organization</b> .....	<b>20</b>		

## Applications

The CYRF69103 PRoC LP is targeted for the following applications:

- Wireless HID devices:
  - Mice
  - Remote Controls
  - Presenter tools
  - Barcode scanners
  - POS terminal
- General purpose wireless applications:
  - Industrial applications
  - Home automation
  - White goods
  - Consumer electronics
  - Toys

## Functional Description

PRoC LP devices are integrated radio and microcontroller functions in the same package to provide a dual-role single-chip solution.

Communication between the microcontroller and the radio is through the radio's SPI interface.

## Functional Overview

The CYRF69103 is a complete Radio System-on-Chip device, providing a complete RF system solution with a single device and a few discrete components. The CYRF69103 is designed to implement low cost wireless systems operating in the worldwide 2.4 GHz Industrial, Scientific, and Medical (ISM) frequency band (2.400 GHz to 2.4835 GHz).

### 2.4 GHz Radio Function

The SoC contains a 2.4 GHz 1 Mbps GFSK radio transceiver, packet data buffering, packet framer, DSSS baseband controller, Received Signal Strength Indication (RSSI), and SPI interface for data transfer and device configuration.

The radio supports 98 discrete 1 MHz channels (regulations may limit the use of some of these channels in certain jurisdictions). In DSSS modes the baseband performs DSSS spreading/despreading, while in GFSK Mode (1 Mb/s - GFSK) the baseband performs Start of Frame (SOF), End of Frame (EOF) detection, and CRC16 generation and checking. The baseband may also be configured to automatically transmit Acknowledge (ACK) handshake packets whenever a valid packet is received.

When in receive mode, with packet framing enabled, the device is always ready to receive data transmitted at any of the supported bit rates, except SDR, enabling the implementation of mixed-rate systems in which different devices use different data rates. This also enables the implementation of dynamic data rate systems, which use high data rates at shorter distances and/or in a low moderate interference environment, and change to lower data rates at longer distances and/or in high interference environments.

The radio meets the following worldwide regulatory requirements:

- Europe:
  - ETSI EN 301 489-1 V1.4.1
  - ETSI EN 300 328-1 V1.3.1
- North America:
  - FCC CFR 47 Part 15
- Japan:
  - ARIB STD-T66

### Data Transmission Modes

The radio supports four different data transmission modes:

- In GFSK mode, data is transmitted at 1 Mbps, without any DSSS
- In 8DR mode, 1 byte is encoded in each PN code symbol transmitted
- In DDR mode, 2 bits are encoded in each PN code symbol transmitted
- In SDR mode, a single bit is encoded in each PN code symbol transmitted

Both 64-chip and 32-chip data PN codes are supported. The four data transmission modes apply to the data after the Start of Packet (SOP). In particular, the packet length, data and CRC are all sent in the same mode.

### Microcontroller Function

The MCU function is an 8-bit Flash-programmable microcontroller. The instruction set is optimized specifically for HID and a variety of other embedded applications.

The MCU function has up to 8 Kbytes of Flash for user's code and up to 256 bytes of RAM for stack space and user variables.

In addition, the MCU function includes a Watchdog timer, a vectored interrupt controller, a 16-bit Free Running Timer, and 12-bit Programmable Interrupt Timer.

The microcontroller has 15 GPIO pins grouped into multiple ports. With the exception of the four radio function GPIOs, each GPIO port supports high impedance inputs, configurable pull up, open drain output, CMOS/TTL inputs and CMOS output. Up to two pins support programmable drive strength of up to 50 mA. Additionally, each I/O pin can be used to generate a GPIO interrupt to the microcontroller. Each GPIO port has its own GPIO interrupt vector with the exception of GPIO Port 0. GPIO Port 0 has two dedicated pins that have independent interrupt vectors (P0.3–P0.4).

The microcontroller features an internal oscillator.

The PRoC LP includes a Watchdog timer, a vectored interrupt controller, a 12-bit programmable interval timer with configurable 1 ms interrupt and a 16-bit free running timer.

In addition, the CYRF69103 IC has a Power Management Unit (PMU), which enables direct connection of the device to any battery voltage in the range 1.8 V to 3.6 V. The PMU conditions the battery voltage to provide the supply voltages required by the device and may supply external devices.

**Backward Compatibility**

The CYRF69103 IC is fully interoperable with the main modes of the first generation Cypress radios namely the CYWUSB6934-LS and CYWWUSB6935-LR devices. The 62.5 kbps mode is supported by selecting 32 chip DDR mode. Similarly, the 15.675 kbps mode is supported by selecting 64 chip SDR mode. In this method, a suitably configured CYRF69103 IC device may transmit data to or receive data from a first generation device, or both. Backwards compatibility requires disabling the SOP, length, and CRC16 fields.

This section provides the different configurations of the registers and firmware that enable a new generation radio to communicate with a first generation radio. There are two possible modes: SDR and DDR mode (8-DR and GFSK modes are not present in the first generation radio). The second generation radio must be initialized using the RadiolnitAPI of the LP radio driver and then the following registers' bits need to be configured to the given Byte values. Essentially, the following deactivates the added features of the second generation radio and takes it down to the level of the first generation radio. The data format, data rates, and the PN codes used are recognizable by the first generation radio.

**DDR Mode**

**Table 1. DDR Mode**

Register	Value	Description
TX_CFG_ADR	0X16	32 chip PN Code, DDR, PA = 6
RX_CFG_ADR	0X4B	AGC is enabled. LNA and attenuator are disabled. Fast turnaround is disabled, the device uses high side receive injection and Hi-Lo is disabled. Overwrite to receive buffer is enabled and the RX buffer is configured to receive eight bytes maximum.
XACT_CFG_ADR	0X05	AutoACK is disabled. Forcing end state is disabled. The device is configured to transition to Idle mode after a Receive or Transmit. ACK timeout is set to 128 $\mu$ s.
FRAMING_CFG_ADR	0X00	All SOP and framing features are disabled. Disable LEN_EN = 0 if EOP is needed.
TX_OVERRIDE_ADR	0X04	Disable Transmit CRC-16.
RX_OVERRIDE_ADR	0X14	The receiver rejects packets with a zero seed. The Rx CRC-16 Checker is disabled and the receiver accepts bad packets that do not match the seed in CRC_seed registers. This helps in communication with the first generation radio that does not have CRC capabilities.
ANALOG_CTRL_ADR	0X01	Set ALL SLOW. When set, the synthesizer settle time for all channels is the same as the slow channels in the first generation radio.
DATA32_THOLD_ADR	0X03	Sets the number of allowed corrupted bits to 3.
EOP_CTRL_ADR	0x01	Sets the number of consecutive symbols for non-correlation to detect end of packet.
PREAMBLE_ADR	0xAAAA05	AAAA are the two preamble bytes. Any other byte can also be written into the preamble register file. Recommended counts of the preamble bytes to be sent must be >4.

**SDR Mode**

**Table 2. SDR Mode**

Register	Value	Description
TX_CFG_ADR	0X3E	64 chip PN code, SDR mode, PA = 6
RX_CFG_ADR	0X4B	AGC is enabled. LNA and attenuator are disabled. Fast turnaround is disabled, the device uses high side receive injection and Hi-Lo is disabled. Overwrite to receive buffer is enabled and RX buffer is configured to receive eight bytes maximum. Enables RXOW to allow new packets to be loaded into the receive buffer. This also enables the VALID bit which is used by the first generation radio's error correction firmware.
XACT_CFG_ADR	0X05	AutoACK is disabled. Forcing end state is disabled. The device is configured to transition to Idle mode after Receive or Transmit. ACK timeout is set to 128 $\mu$ s.
FRAMING_CFG_ADR	0X00	All SOP and framing features are disabled. Disable LEN_EN=0 if EOP is needed.
TX_OVERRIDE_ADR	0X04	Disable Transmit CRC-16.
RX_OVERRIDE_ADR	0X14	The receiver rejects packets with a zero seed. The RX CRC-16 checker is disabled and the receiver accepts bad packets that do not match the seed in the CRC_seed registers. This helps in communication with the first generation radio that does not have CRC capabilities.
ANALOG_CTRL_ADR	0X01	Set ALL SLOW. When set, the synthesizer settle time for all channels is the same as the slow channels in the first generation radio, for manual ACK consistency
DATA64_THOLD_ADR	0X07	Sets the number of allowed corrupted bits to 7 which is close to the recommended 12% value.
EOP_CTRL_ADR	0xA1	Sets the number of consecutive symbols for non-correlation to detect end of packet.
PREAMBLE_ADR	0xAAAA09	AAAA are the two preamble bytes. Any other byte can also be written into the preamble register file. Recommended counts of the preamble bytes to be sent must be >8.

Pinouts

Figure 1. Pin Diagram

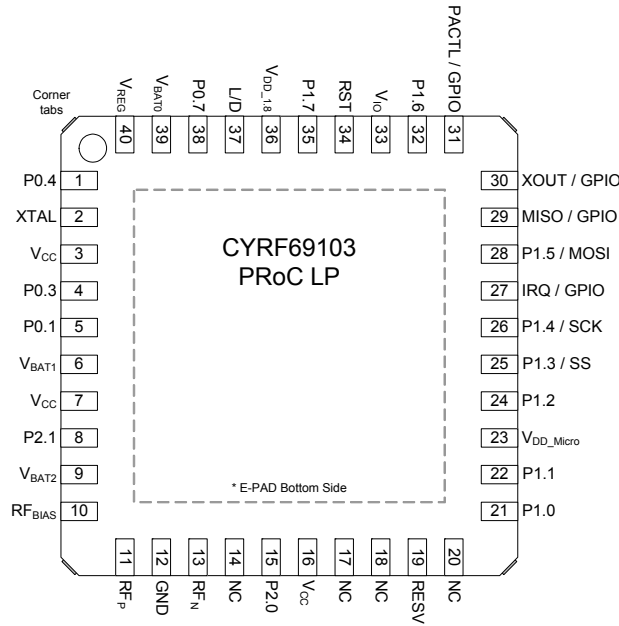

Pin Definitions

Pin	Name	Description
1	P0.4	Individually configured GPIO
2	XTAL	12 MHz crystal
3, 7, 16	V <sub>CC</sub>	2.4 V to 3.6 V supply. Connected to pin 40 (0.047 μF bypass)
4	P0.3	Individually configured GPIO
5	P0.1	Individually configured GPIO
6	V <sub>bat1</sub>	Connect to 1.8 V to 3.6 V power supply, through 47 ohm series/1 μF shunt C.
8	P2.1	GPIO. Port 2 Bit 1
9	V <sub>bat2</sub>	Connected to 1.8 V to 3.6 V main power supply, through 0.047 μF bypass C.
10	RF <sub>bias</sub>	RF pin voltage reference
11	RF <sub>p</sub>	Differential RF to or from antenna
12	GND	GND
13	RF <sub>n</sub>	Differential RF to or from antenna
14, 17, 18, 20	NC	
15	P2.0	GPIO
19	RESV	Reserved. Must connect to GND
21	P1.0	GPIO port 1 bit 0 / ISSP-SCLK If this pin is used as a general-purpose output it draws current. It is, therefore, configured as an input to reduce current draw.
22	P1.1	GPIO port 1 bit 1 / ISSP-SDATA If this pin is used as a general-purpose output it draws current. It is, therefore, configured as an input to reduce current draw.
23	V <sub>DD_micro</sub>	MCU supply connected to pin 40, max CPU 12 MHz

**Pin Definitions** (continued)

Pin	Name	Description
24	P1.2	GPIO
25	P1.3 / nSS	Slave Select
26	P1.4 / SCK	SPI Clock
27	IRQ	Radio Function Interrupt output, configure High, Low or as Radio GPIO.
28	P1.5 / MOSI	MOSI pin from microcontroller function to radio function.
29	MISO	3-wire SPI mode configured as Radio GPIO. In 4-wire SPI mode sends data to MCU function.
30	XOUT	Buffered CLK, PACTL_n or Radio GPIO.
31	PACTL	Control for external PA or Radio GPIO.
32	P1.6	GPIO
33	V <sub>IO</sub>	1.8 V to 3.6V to main power supply rail for Radio I/O.
34	RST	Radio Reset. Connected to pin 40 with 0.47 μF. Must have a RST = HIGH event the very first time power is applied to the radio otherwise the state of the radio control registers is unknown.
35	P1.7	GPIO
36	V <sub>DD1.8</sub>	Regulated logic bypass. Connected to 0.47 μF to GND.
37	L/D	Inductor/Diode connection for Boost. When Internal PMU is not being used connect L/D to GND.
38	P0.7	GPIO
39	V <sub>bat0</sub>	Connected to 1.8 V to 3.6 V main power supply, through 0.047 μF bypass C.
40	V <sub>REG</sub>	Boost regulator output voltage feedback
41	E-pad	Must be connected to ground.
42	Corner Tabs	Do Not connect corner tabs.

**Functional Block Overview**

All the blocks that make up the PRoC LP are presented in this section.

**2.4 GHz Radio**

The radio transceiver is a dual conversion low IF architecture optimized for power and range/robustness. The radio employs channel matched filters to achieve high performance in the presence of interference. An integrated Power Amplifier (PA) provides up to +4 dBm transmit power, with an output power control range of 34 dB in eight steps. The supply current of the device is reduced as the RF output power is reduced.

**Table 3. Internal PA Output Power Step Table**

PA Setting	Typical Output Power (dBm)
7	+4
6	0
5	-5
4	-10
3	-15
2	-20
1	-25
0	-30

**Frequency Synthesizer**

Before transmission or reception may commence, it is necessary for the frequency synthesizer to settle. The settling time varies depending on channel; 25 fast channels are provided with a maximum settling time of 100 μs.

The “fast channels” (<100 μs settling time) are every 3<sup>rd</sup> frequency, starting at 2400 MHz up to and including 2472 MHz (that is, 0,3,6,9.....69 and 72).

**Baseband and Framer**

The baseband and framer blocks provide the DSSS encoding and decoding, SOP generation and reception and CRC16 generation and checking, and EOP detection and length field.

*Data Transmission Modes and Data Rates*

The SoC supports four different data transmission modes:

- In GFSK mode, data is transmitted at 1 Mbps, without any DSSS.
- In 8DR mode, 8 bits are encoded in each DATA\_CODE\_ADR derived code symbol transmitted.
- In DDR mode, 2 bits are encoded in each DATA\_CODE\_ADR derived code symbol transmitted (as in the CYWUSB6934 DDR mode).
- In SDR mode, 1 bit is encoded in each DATA\_CODE\_ADR derived code symbol transmitted (as in the CYWUSB6934 standard modes).



Both 64-chip and 32-chip DATA\_CODE\_ADR codes are supported. The four data transmission modes apply to the data after the SOP. In particular the length, data, and CRC16 are all sent in the same mode. In general, lower data rates reduces packet error rate in any given environment.

The CYRF69103 IC supports the following data rates:

- 1000 kbps (GFSK)
- 250 kbps (32-chip 8DR)
- 125 kbps (64-chip 8DR)
- 62.5 kbps (32-chip DDR)
- 31.25 kbps (64-chip DDR)
- 15.625 kbps (64-chip SDR)

Lower data rates typically provide longer range and/or a more robust link.

*Link Layer Modes*

The CYRF69103 IC device supports the following data packet framing features:

**SOP** – Packets begin with a 2-symbol Start of Packet (SOP) marker. This is required in GFSK and 8DR modes, but is optional in DDR mode and is not supported in SDR mode. If framing is disabled then an SOP event is inferred whenever two successive correlations are detected. The SOP\_CODE\_ADR code used for the SOP is different from that used for the “body” of the packet, and if desired may be a different length. SOP must be configured to be the same length on both sides of the link.

**EOP** – There are two options for detecting the end of a packet. If SOP is enabled, then a packet length field may be enabled. GFSK and 8DR must enable the length field. This is the first 8 bits after the SOP symbol, and is transmitted at the payload data rate. If the length field is enabled, an End of Packet (EOP) condition is inferred after reception of the number of bytes defined in the length field, plus two bytes for the CRC16 (if enabled). The alternative to using the length field is to infer an EOP condition from a configurable number of successive non correlations; this option is not available in GFSK mode and is only recommended when using SDR mode.

**CRC16** – The device may be configured to append a 16-bit CRC16 to each packet. The CRC16 uses the USB CRC polynomial with the added programmability of the seed. If enabled, the receiver verifies the calculated CRC16 for the payload data against the received value in the CRC16 field. The starting value for the CRC16 calculation is configurable, and the CRC16 transmitted may be calculated using either the loaded seed value or a zero seed; the received data CRC16 is checked against both the configured and zero CRC16 seeds.

CRC16 detects the following errors:

- Any one bit in error
- Any two bits in error (no matter how far apart, which column, and so on)
- Any odd number of bits in error (no matter where they are)
- An error burst as wide as the checksum itself

Figure 2 shows an example packet with SOP, CRC16 and lengths fields enabled.

**Figure 2. Example Default Packet Format**

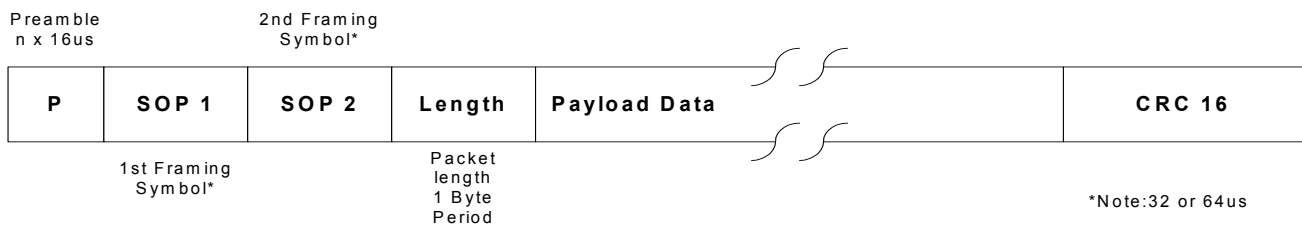

**Packet Buffers and Radio Configuration Registers**

Packet data and configuration registers are accessed through the SPI interface. All configuration registers are directly addressed through the address field in the SPI packet (as in the CYWUSB6934). Configuration registers are provided to allow configuration of DSSS PN codes, data rate, operating mode, interrupt masks, interrupt status, and others.

*Packet Buffers*

All data transmission and reception use the 16-byte packet buffers: one for transmission and one for reception.

The transmit buffer allows a complete packet of up to 16 bytes of payload data to be loaded in one burst SPI transaction, and then transmitted with no further MCU intervention. Similarly, the receive buffer allows an entire packet of payload data up to 16 bytes to be received with no firmware intervention required until packet reception is complete.

The CYRF69103 IC supports packet length of up to 40 bytes; interrupts are provided to allow an MCU to use the transmit and receive buffers as FIFOs. When transmitting a packet longer than 16 bytes, the MCU can load 16 bytes initially, and add further bytes to the transmit buffer as transmission of data creates space in the buffer. Similarly, when receiving packets longer than 16 bytes, the MCU must fetch received data from the FIFO periodically during packet reception to prevent it from overflowing.

**Auto Transaction Sequencer (ATS)**

The CYRF69103 IC provides automated support for transmission and reception of acknowledged data packets.

When transmitting a data packet, the device automatically starts the crystal and synthesizer, enters transmit mode, transmits the packet in the transmit buffer, and then automatically switches to receive mode and waits for a handshake packet – and then

automatically reverts to sleep mode or idle mode when either an ACK packet is received, or a time out period expires.

Similarly, when receiving in transaction mode, the device waits in receive mode for a valid packet to be received, then automatically transitions to transmit mode, transmits an ACK packet, and then switches back to receive mode to await the next packet. The contents of the packet buffers are not affected by the transmission or reception of ACK packets.

In each case, the entire packet transaction takes place without any need for MCU firmware action; to transmit data the MCU simply needs to load the data packet to be transmitted, set the length, and set the TX GO bit. Similarly, when receiving packets in transaction mode, firmware simply needs to retrieve the fully received packet in response to an interrupt request indicating reception of a packet.

### Interrupts

The radio function provides an interrupt (IRQ) output, which is configurable to indicate the occurrence of various different events. The IRQ pin may be programmed to be either active high or active low, and be either a CMOS or open drain output.

The radio function features three sets of interrupts: transmit, receive, and system interrupts. These interrupts all share a single pin (IRQ), but can be independently enabled/disabled. In transmit mode, all receive interrupts are automatically disabled, and in receive mode all transmit interrupts are automatically disabled. However, the contents of the enable registers are preserved when switching between transmit and receive modes.

If more than one radio interrupt is enabled at any time, it is necessary to read the relevant status register to determine which event caused the IRQ pin to assert. Even when a given interrupt source is disabled, the status of the condition that would otherwise cause an interrupt can be determined by reading the appropriate status register. It is therefore possible to use the devices without making use of the IRQ pin by polling the status register(s) to wait for an event, rather than using the IRQ pin.

### Clocks

A 12 MHz crystal (30 ppm or better) is directly connected between XTAL and GND without the need for external capacitors. A digital clock out function is provided, with selectable output frequencies of 0.75, 1.5, 3, 6, or 12 MHz. This output may be used to clock an external microcontroller (MCU) or ASIC. This output is enabled by default, but may be disabled.

The requirements for the crystal to be directly connected to XTAL pin and GND are:

- Nominal Frequency: 12 MHz
- Operating Mode: Fundamental Mode
- Resonance Mode: Parallel Resonant
- Frequency Initial Stability:  $\pm 30$  ppm
- Series Resistance:  $\leq 60$  ohms
- Load Capacitance: 10 pF
- Drive Level: 100  $\mu$ W

The MCU function features an internal oscillator. The clock generator provides the 12 MHz and 24 MHz clocks that remain internal to the microcontroller.

### GPIO Interface

The MCU function features up to 15 general purpose I/O (GPIO) pins. The I/O pins are grouped into three ports (Port 0 to 2). The pins on Port 0 and Port 1 may each be configured individually while the pins on Port 2 may only be configured as a group. Each GPIO port supports high-impedance inputs, configurable pull up, open drain output, CMOS/TTL inputs, and CMOS output with up to two pins that support programmable drive strength of up to 50 mA sink current. Additionally, each I/O pin can be used to generate a GPIO interrupt to the microcontroller. Each GPIO port has its own GPIO interrupt vector with the exception of GPIO Port 0. GPIO Port 0 has three dedicated pins that have independent interrupt vectors (P0.1, P0.3–P0.4).

### Power On Reset/Low Voltage Detect

The power on reset circuit detects logic when power is applied to the device, resets the logic to a known state, and begins executing instructions at Flash address 0x0000. When power falls below a programmable trip voltage, it generates reset or may be configured to generate interrupt. There is a low voltage detect circuit that detects when  $V_{CC}$  drops below a programmable trip voltage. It may be configurable to generate an LVD interrupt to inform the processor about the low voltage event. POR and LVD share the same interrupt. There is not a separate interrupt for each. The Watchdog timer can be used to ensure the firmware never gets stalled in an infinite loop.

### Timers

The free running 16-bit timer provides two interrupt sources: the programmable interval timer with 1- $\mu$ s resolution and the 1.024 ms outputs. The timer can be used to measure the duration of an event under firmware control by reading the timer at the start and at the end of an event, then calculating the difference between the two values.

### Power Management

The operating voltage of the device is 1.8V to 3.6V DC, which is applied to the  $V_{BAT}$  pin. The device can be shut down to a fully static sleep mode by writing to the FRC END = 1 and END STATE = 000 bits in the XACT\_CFG\_ADR register over the SPI interface. The device enters sleep mode within 35  $\mu$ s after the last SCK positive edge at the end of this SPI transaction. Alternatively, the device may be configured to automatically enter sleep mode after completing packet transmission or reception. When in sleep mode, the on-chip oscillator is stopped, but the SPI interface remains functional. The device wakes from sleep mode automatically when the device is commanded to enter transmit or receive mode. When resuming from sleep mode, there is a short delay while the oscillator restarts. The device may be configured to assert the IRQ pin when the oscillator has stabilized.

The output voltage ( $V_{REG}$ ) of the Power Management Unit (PMU) is configurable to several minimum values between 2.4 V and 2.7 V.  $V_{REG}$  may be used to provide up to 15 mA (average load) to external devices. It is possible to disable the PMU, and to provide an externally regulated DC supply voltage to the

device in the range 2.4 V to 3.6 V. The PMU also provides a regulated 1.8 V supply to the logic.

The PMU has been designed to provide high boost efficiency (74–85% depending on input voltage, output voltage and load) when using a Schottky diode and power inductor, eliminating the need for an external boost converter in many systems where other components require a boosted voltage. However, reasonable efficiencies (69–82% depending on input voltage, output voltage and load) may be achieved when using low-cost components such as SOT23 diodes and 0805 inductors.

The current through the diode must stay within the linear operating range of the diode. For some loads the SOT23 diode is sufficient, but with higher loads it is not and a SS12 diode must be used to stay within this linear range of operation. Along with the diode, the inductor used must not saturate its core. In higher loads, a lower resistance/higher saturation coil like the inductor from Sumida must be used.

The PMU also provides a configurable low battery detection function which may be read over the SPI interface. One of seven thresholds between 1.8 V and 2.7 V may be selected. The interrupt pin may be configured to assert when the voltage on the  $V_{BAT}$  pin falls below the configured threshold. LV IRQ is not a latched event. Battery monitoring is disabled when the device is in sleep mode.

The following three figures show different examples of how to use PRoC LP with and without the PMU. **Figure 3** shows the most common circuit making use of the PMU to boost battery voltage up to 2.7 V. **Figure 4** is an example of the circuit used when the supply voltage is always above 2.7 V. This could be three 1.5 V battery cells in series along with a linear regulator, or some similar power source. **Figure 5** shows an example of using the PRoC LP with its PMU disabled and an external boost to supply power to the device. This might be required when the load is much greater than the 15 mA average load that PRoC can support.

**Figure 3. PMU Enabled**

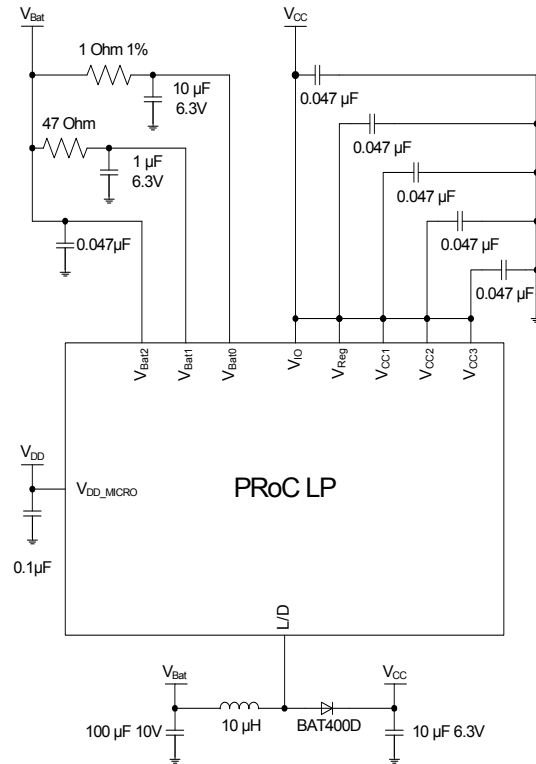

**Figure 4. PMU Disabled - Linear Regulator**

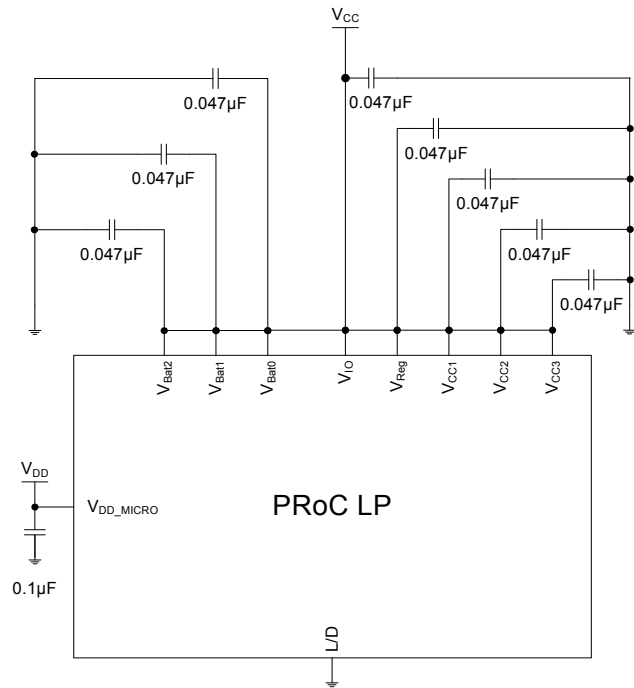
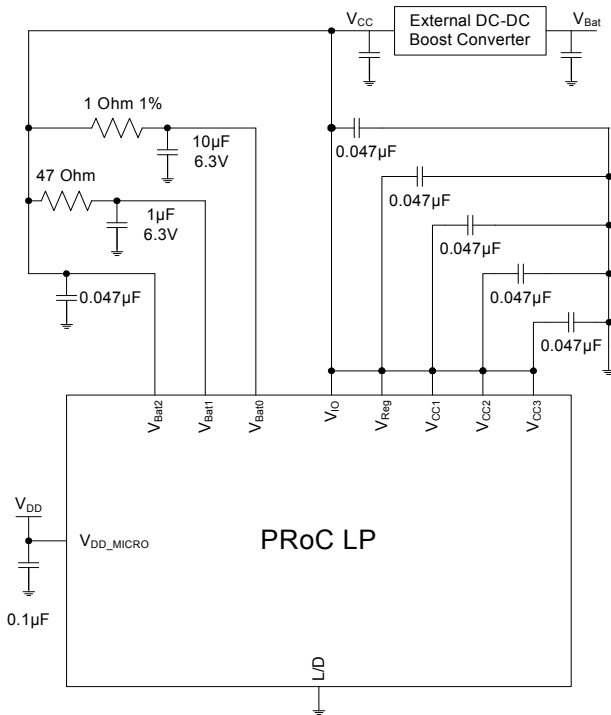

Figure 5. PMU Disabled - External Boost Converter



### Low Noise Amplifier (LNA) and Received Signal Strength Indication (RSSI)

The gain of the receiver may be controlled directly by clearing the AGC EN bit and writing to the Low Noise Amplifier (LNA) bit of the RX\_CFG\_ADR register. When the LNA bit is cleared, the receiver gain is reduced by approximately 20 dB, allowing accurate reception of very strong received signals (for example when operating a receiver very close to the transmitter). An additional 20 dB of receiver attenuation can be added by setting the Attenuation (ATT) bit; this allows data reception to be limited to devices at very short ranges. Disabling AGC and enabling LNA is recommended unless receiving from a device using external PA.

The RSSI register returns the relative signal strength of the on-channel signal power.

When receiving, the device may be configured to automatically measure and store the relative strength of the signal being received as a 5-bit value. When enabled, an RSSI reading is taken and may be read through the SPI interface. An RSSI reading is taken automatically when the start of a packet is detected. In addition, a new RSSI reading is taken every time the previous reading is read from the RSSI register, allowing the background RF energy level on any given channel to be easily measured when RSSI is read when no signal is being received. A new reading can occur as fast as once every 12 µs.

### Receive Spurious Response

The transmitter may exhibit spurs around 50MHz offset at levels approximately 50dB to 60dB below the carrier power. Receivers

operating at the transmit spur frequency may receive the spur if the spur level power is greater than the receive sensitivity level.

The workaround for this is to program an additional byte in the packet header which contains the transmitter channel number. After the packet is received, the channel number can be checked. If the channel number does not match the receive channel then the packet is rejected.

### SPI Interface

The SPI interface between the MCU function and the radio function is a 3-wire SPI Interface. The three pins are MOSI (Master Out Slave In), SCK (Serial Clock), SS (Slave Select). There is an alternate 4-wire MISO Interface that requires the connection of two external pins. The SPI interface is controlled by configuring the SPI Configure Register. (SPICR Addr: 0x3D).

### 3-Wire SPI Interface

The radio function receives a clock from the MCU function on the SCK pin. The MOSI pin is multiplexed with the MISO pin. Bidirectional data transfer takes place between the MCU function and the radio function through this multiplexed MOSI pin. When using this mode the user firmware must ensure that the MOSI pin on the MCU function is in a high impedance state, except when the MCU is actively transmitting data. Firmware must also control the direction of data flow and switch directions between MCU function and radio function by setting the SWAP bit [Bit 7] of the SPI Configure Register. The SS pin is asserted before initiating a data transfer between the MCU function and the radio function. The IRQ function may be optionally multiplexed with the MOSI pin; when this option is enabled the IRQ function is not available while the SS pin is low. When using this configuration, user firmware must ensure that the MOSI function on MCU function is in a high-impedance state whenever SS is high.

Figure 6. 3-Wire SPI Mode

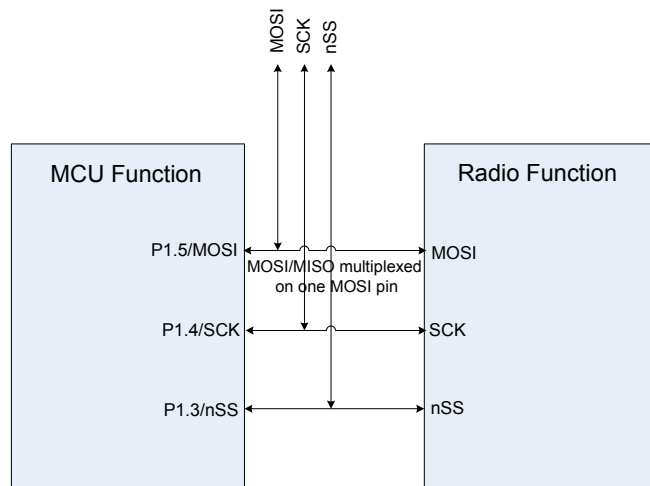

### 4-Wire SPI Interface

The 4-wire SPI communications interface consists of MOSI, MISO, SCK, and SS.

The device receives SCK from the MCU function on the SCK pin. Data from the MCU function is shifted in on the MOSI pin. Data to the MCU function is shifted out on the MISO pin. The active low SS pin must be asserted for the two functions to communicate. The IRQ function may be optionally multiplexed with the MOSI pin; when this option is enabled the IRQ function is not available while the SS pin is low. When using this configuration, user firmware must ensure that the MOSI function on MCU function is in a high-impedance state whenever SS is high.

**Figure 7. 4-Wire SPI Mode**

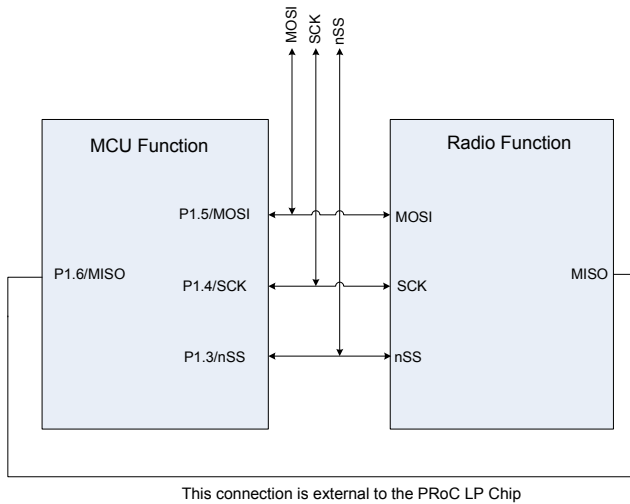

### SPI Communication and Transactions

The SPI transactions can be single byte or multi-byte. The MCU function initiates a data transfer through a Command/Address

**Table 4. SPI Transaction Format**

	Byte 1			Byte 1+N
<b>Bit #</b>	7	6	[5:0]	[7:0]
<b>Bit Name</b>	DIR	INC	Address	Data

byte. The following bytes are data bytes. The SPI transaction format is shown in Figure 4.

The DIR bit specifies the direction of data transfer. 0 = Master reads from slave. 1 = Master writes to slave.

The INC bit helps to read or write consecutive bytes from contiguous memory locations in a single burst mode operation.

If Slave Select is asserted and INC = 1, then the master MCU function reads a byte from the radio, the address is incremented by a byte location, and then the byte at that location is read, and so on.

If Slave Select is asserted and INC = 0, then the MCU function reads/writes the bytes in the same register in burst mode, but if it is a register file then it reads/writes the bytes in that register file.

The SPI interface between the radio function and the MCU is not dependent on the internal 12 MHz oscillator of the radio. Therefore, radio function registers can be read from or written into while the radio is in sleep mode.

### SPI I/O Voltage References

The SPI interfaces between MCU function and the radio and the IRQ and RST have a separate voltage reference  $V_{IO}$ . For CYRF69103  $V_{IO}$  is normally set to  $V_{CC}$ .

### SPI Connects to External Devices

The three SPI wires, MOSI, SCK, and SS are also drawn out of the package as external pins to allow the user to interface their own external devices (such as optical sensors and others) through SPI. The radio function also has its own SPI wires MISO and IRQ, which can be used to send data back to the MCU function or send an interrupt request to the MCU function. They can also be configured as GPIO pins.

## CPU Architecture

This family of microcontrollers is based on a high-performance, 8-bit, Harvard architecture microprocessor. Five registers control the primary operation of the CPU core. These registers are affected by various instructions, but are not directly accessible through the register space by the user.

**Table 5. CPU Registers and Register Name**

Register	Register Name
Flags	CPU_F
Program Counter	CPU_PC
Accumulator	CPU_A
Stack Pointer	CPU_SP
Index	CPU_X

The 16-bit Program Counter Register (CPU\_PC) allows for direct addressing of the full eight Kbytes of program memory space.

The Accumulator Register (CPU\_A) is the general-purpose register that holds the results of instructions that specify any of the source addressing modes.

The Index Register (CPU\_X) holds an offset value that is used in the indexed addressing modes. Typically, this is used to address a block of data within the data memory space.

The Stack Pointer Register (CPU\_SP) holds the address of the current top-of-stack in the data memory space. It is affected by the PUSH, POP, LCALL, CALL, RETI, and RET instructions, which manage the software stack. It can also be affected by the SWAP and ADD instructions.

The Flag Register (CPU\_F) has three status bits: Zero Flag bit [1]; Carry Flag bit [2]; Supervisory State bit [3]. The Global Interrupt Enable bit [0] is used to globally enable or disable interrupts. The user cannot manipulate the Supervisory State status bit [3]. The flags are affected by arithmetic, logic, and shift operations. The manner in which each flag is changed is dependent upon the instruction being executed (for example, AND, OR, XOR). See [Table 22](#) on page 19.

## CPU Registers

### Flags Register

The Flags Register can only be set or reset with logical instruction.

**Table 6. CPU Flags Register (CPU\_F) [R/W]**

Bit #	7	6	5	4	3	2	1	0
Field	Reserved			XIO	Super	Carry	Zero	Global IE
Read/Write	–	–	–	R/W	R	RW	RW	RW
Default	0	0	0	0	0	0	1	0

**Bits 7:5** Reserved

**Bit 4** XIO  
Set by the user to select between the register banks.  
0 = Bank 0  
1 = Bank 1

**Bit 3** Super  
Indicates whether the CPU is executing user code or Supervisor Code (This code cannot be accessed directly by the user).  
0 = User Code  
1 = Supervisor Code

**Bit 2** Carry  
Set by CPU to indicate whether there has been a carry in the previous logical/arithmetic operation.  
0 = No Carry  
1 = Carry

**Bit 1** Zero  
Set by CPU to indicate whether there has been a zero result in the previous logical/arithmetic operation.  
0 = Not Equal to Zero  
1 = Equal to Zero

**Bit 0** Global IE  
Determines whether all interrupts are enabled or disabled.  
0 = Disabled  
1 = Enabled

**Note** This register is readable with explicit address 0xF7. The *OR F, expr* and *AND F, expr* must be used to set and clear the CPU\_F bits.

### Accumulator Register

**Table 7. CPU Accumulator Register (CPU\_A)**

Bit #	7	6	5	4	3	2	1	0
Field	CPU Accumulator [7:0]							
Read/Write	–	–	–	–	–	–	–	–
Default	0	0	0	0	0	0	0	0

**Bits 7:0** CPU Accumulator [7:0]  
8-bit data value holds the result of any logical/arithmetic instruction that uses a source addressing mode.

**Index Register**

**Table 8. CPU X Register (CPU\_X)**

Bit #	7	6	5	4	3	2	1	0
Field	X [7:0]							
Read/Write	–	–	–	–	–	–	–	–
Default	0	0	0	0	0	0	0	0

**Bits 7:0** X [7:0]  
8-bit data value holds an index for any instruction that uses an indexed addressing mode.

**Stack Pointer Register**

**Table 9. CPU Stack Pointer Register (CPU\_SP)**

Bit #	7	6	5	4	3	2	1	0
Field	Stack Pointer [7:0]							
Read/Write	–	–	–	–	–	–	–	–
Default	0	0	0	0	0	0	0	0

**Bits 7:0** Stack Pointer [7:0]  
8-bit data value holds a pointer to the current top-of-stack.

**CPU Program Counter High Register**

**Table 10. CPU Program Counter High Register (CPU\_PCH)**

Bit #	7	6	5	4	3	2	1	0
Field	Program Counter [15:8]							
Read/Write	–	–	–	–	–	–	–	–
Default	0	0	0	0	0	0	0	0

**Bits 7:0** Program Counter [15:8]  
8-bit data value holds the higher byte of the program counter.

**CPU Program Counter Low Register**

**Table 11. CPU Program Counter Low Register (CPU\_PCL)**

Bit #	7	6	5	4	3	2	1	0
Field	Program Counter [7:0]							
Read/Write	–	–	–	–	–	–	–	–
Default	0	0	0	0	0	0	0	0

**Bit 7:0** Program Counter [7:0]  
8-bit data value holds the lower byte of the program counter.



## Addressing Modes

Examples of the different addressing modes are discussed in this section and example code is given.

### Source Immediate

The result of an instruction using this addressing mode is placed in the A register, the F register, the SP register, or the X register, which is specified as part of the instruction opcode. Operand 1 is an immediate value that serves as a source for the instruction. Arithmetic instructions require two sources. Instructions using this addressing mode are two bytes in length.

**Table 12. Source Immediate**

Opcode	Operand 1
Instruction	Immediate Value

#### Examples

- ADD A, 7 In this case, the immediate value of 7 is added with the Accumulator, and the result is placed in the Accumulator.
- MOV X, 8 In this case, the immediate value of 8 is moved to the X register.
- AND F, 9 In this case, the immediate value of 9 is logically ANDed with the F register and the result is placed in the F register.

### Source Direct

The result of an instruction using this addressing mode is placed in either the A register or the X register, which is specified as part of the instruction opcode. Operand 1 is an address that points to a location in either the RAM memory space or the register space that is the source for the instruction. Arithmetic instructions require two sources; the second source is the A register or X register specified in the opcode. Instructions using this addressing mode are two bytes in length.

**Table 13. Source Direct**

Opcode	Operand 1
Instruction	Source Address

#### Examples

- ADD A, [7] In this case, the value in the RAM memory location at address 7 is added with the Accumulator, and the result is placed in the Accumulator.
- MOV X, REG[8] In this case, the value in the register space at address 8 is moved to the X register.

### Source Indexed

The result of an instruction using this addressing mode is placed in either the A register or the X register, which is specified as part of the instruction opcode. Operand 1 is added to the X register forming an address that points to a location in either the RAM memory space or the register space that is the source for the instruction. Arithmetic instructions require two sources; the second source is the A register or X register specified in the opcode. Instructions using this addressing mode are two bytes in length.

**Table 14. Source Indexed**

Opcode	Operand 1
Instruction	Source Index

#### Examples

- ADD A, [X+7] In this case, the value in the memory location at address X + 7 is added with the Accumulator, and the result is placed in the Accumulator.
- MOV X, REG[X+8] In this case, the value in the register space at address X + 8 is moved to the X register.

### Destination Direct

The result of an instruction using this addressing mode is placed within either the RAM memory space or the register space. Operand 1 is an address that points to the location of the result. The source for the instruction is either the A register or the X register, which is specified as part of the instruction opcode. Arithmetic instructions require two sources; the second source is the location specified by Operand 1. Instructions using this addressing mode are two bytes in length.

**Table 15. Destination Direct**

Opcode	Operand 1
Instruction	Destination Address

#### Examples

- ADD [7], A In this case, the value in the memory location at address 7 is added with the Accumulator, and the result is placed in the memory location at address 7. The Accumulator is unchanged.
- MOV REG[8], A In this case, the Accumulator is moved to the register space location at address 8. The Accumulator is unchanged.

**Destination Indexed**

The result of an instruction using this addressing mode is placed within either the RAM memory space or the register space. Operand 1 is added to the X register forming the address that points to the location of the result. The source for the instruction is the A register. Arithmetic instructions require two sources; the second source is the location specified by Operand 1 added with the X register. Instructions using this addressing mode are two bytes in length.

**Table 16. Destination Indexed**

Opcode	Operand 1
Instruction	Destination Index

**Example**

ADD [X+7], A In this case, the value in the memory location at address X+7 is added with the Accumulator, and the result is placed in the memory location at address x+7. The Accumulator is unchanged.

**Destination Direct Source Immediate**

The result of an instruction using this addressing mode is placed within either the RAM memory space or the register space. Operand 1 is the address of the result. The source for the instruction is Operand 2, which is an immediate value. Arithmetic instructions require two sources; the second source is the location specified by Operand 1. Instructions using this addressing mode are three bytes in length.

**Table 17. Destination Direct Source Immediate**

Opcode	Operand 1	Operand 2
Instruction	Destination Address	Immediate Value

**Examples**

ADD [7], 5 In this case, value in the memory location at address 7 is added to the immediate value of 5, and the result is placed in the memory location at address 7.

MOV REG[8], 6 In this case, the immediate value of 6 is moved into the register space location at address 8.

**Destination Indexed Source Immediate**

The result of an instruction using this addressing mode is placed within either the RAM memory space or the register space. Operand 1 is added to the X register to form the address of the result. The source for the instruction is Operand 2, which is an immediate value. Arithmetic instructions require two sources; the second source is the location specified by Operand 1 added with the X register. Instructions using this addressing mode are three bytes in length.

**Table 18. Destination Indexed Source Immediate**

Opcode	Operand 1	Operand 2
Instruction	Destination Index	Immediate Value

**Examples**

ADD [X+7], 5 In this case, the value in the memory location at address X+7 is added with the immediate value of 5 and the result is placed in the memory location at address X+7.

MOV REG[X+8], 6 In this case, the immediate value of 6 is moved into the location in the register space at address X+8.

**Destination Direct Source Direct**

The result of an instruction using this addressing mode is placed within the RAM memory. Operand 1 is the address of the result. Operand 2 is an address that points to a location in the RAM memory that is the source for the instruction. This addressing mode is only valid on the MOV instruction. The instruction using this addressing mode is three bytes in length.

**Table 19. Destination Direct Source Direct**

Opcode	Operand 1	Operand 2
Instruction	Destination Address	Source Address

**Example**

MOV [7], [8] In this case, the value in the memory location at address 8 is moved to the memory location at address 7.

**Source Indirect Post Increment**

The result of an instruction using this addressing mode is placed in the Accumulator. Operand 1 is an address pointing to a location within the memory space, which contains an address (the indirect address) for the source of the instruction. The indirect address is incremented as part of the instruction execution. This addressing mode is only valid on the MVI instruction. The instruction using this addressing mode is two bytes in length. Refer to the *PSoC Designer: Assembly Language User Guide* for further details on MVI instruction.

**Table 20. Source Indirect Post Increment**

Opcode	Operand 1
Instruction	Source Address Address

**Example**

MVI A, [8] In this case, the value in the memory location at address 8 is an indirect address. The memory location pointed to by the indirect address is moved into the Accumulator. The indirect address is then incremented.

**Destination Indirect Post Increment**

The result of an instruction using this addressing mode is placed within the memory space. Operand 1 is an address pointing to a location within the memory space, which contains an address (the indirect address) for the destination of the instruction. The indirect address is incremented as part of the instruction execution. The source for the instruction is the Accumulator. This addressing mode is only valid on the MVI instruction. The instruction using this addressing mode is two bytes in length.

**Table 21. Destination Indirect Post Increment**

Opcode	Operand 1
Instruction	Destination Address Address

**Example**

MVI [8], A In this case, the value in the memory location at address 8 is an indirect address. The Accumulator is moved into the memory location pointed to by the indirect address. The indirect address is then incremented.

## Instruction Set Summary

The instruction set is summarized in [Table 22](#) numerically and serves as a quick reference. If more information is needed, the Instruction Set Summary tables are described in detail in the *PSoC Designer Assembly Language User Guide* (available on [www.cypress.com](http://www.cypress.com)).

**Table 22. Instruction Set Summary Sorted Numerically by Opcode Order** [1, 2]

Opcode Hex	Cycles	Bytes	Instruction Format	Flags	Opcode Hex	Cycles	Bytes	Instruction Format	Flags	Opcode Hex	Cycles	Bytes	Instruction Format	Flags
00	15	1	SSC		2D	8	2	OR [X+expr], A	Z	5A	5	2	MOV [expr], X	
01	4	2	ADD A, expr	C, Z	2E	9	3	OR [expr], expr	Z	5B	4	1	MOV A, X	Z
02	6	2	ADD A, [expr]	C, Z	2F	10	3	OR [X+expr], expr	Z	5C	4	1	MOV X, A	
03	7	2	ADD A, [X+expr]	C, Z	30	9	1	HALT		5D	6	2	MOV A, reg[expr]	Z
04	7	2	ADD [expr], A	C, Z	31	4	2	XOR A, expr	Z	5E	7	2	MOV A, reg[X+expr]	Z
05	8	2	ADD [X+expr], A	C, Z	32	6	2	XOR A, [expr]	Z	5F	10	3	MOV [expr], [expr]	
06	9	3	ADD [expr], expr	C, Z	33	7	2	XOR A, [X+expr]	Z	60	5	2	MOV reg[expr], A	
07	10	3	ADD [X+expr], expr	C, Z	34	7	2	XOR [X+expr], A	Z	61	6	2	MOV reg[X+expr], A	
08	4	1	PUSH A		35	8	2	XOR [X+expr], A	Z	62	8	3	MOV reg[expr], expr	
09	4	2	ADC A, expr	C, Z	36	9	3	XOR [expr], expr	Z	63	9	3	MOV reg[X+expr], expr	
0A	6	2	ADC A, [expr]	C, Z	37	10	3	XOR [X+expr], expr	Z	64	4	1	ASL A	C, Z
0B	7	2	ADC A, [X+expr]	C, Z	38	5	2	ADD SP, expr		65	7	2	ASL [expr]	C, Z
0C	7	2	ADC [expr], A	C, Z	39	5	2	CMP A, expr	if (A=B) Z=1 if (A<B) C=1	66	8	2	ASL [X+expr]	C, Z
0D	8	2	ADC [X+expr], A	C, Z	3A	7	2	CMP A, [expr]		67	4	1	ASR A	C, Z
0E	9	3	ADC [expr], expr	C, Z	3B	8	2	CMP A, [X+expr]		68	7	2	ASR [expr]	C, Z
0F	10	3	ADC [X+expr], expr	C, Z	3C	8	3	CMP [expr], expr		69	8	2	ASR [X+expr]	C, Z
10	4	1	PUSH X		3D	9	3	CMP [X+expr], expr		6A	4	1	RLC A	C, Z
11	4	2	SUB A, expr	C, Z	3E	10	2	MVI A, [ [expr]++ ]	Z	6B	7	2	RLC [expr]	C, Z
12	6	2	SUB A, [expr]	C, Z	3F	10	2	MVI [ [expr]++ ], A		6C	8	2	RLC [X+expr]	C, Z
13	7	2	SUB A, [X+expr]	C, Z	40	4	1	NOP		6D	4	1	RRC A	C, Z
14	7	2	SUB [expr], A	C, Z	41	9	3	AND reg[expr], expr	Z	6E	7	2	RRC [expr]	C, Z
15	8	2	SUB [X+expr], A	C, Z	42	10	3	AND reg[X+expr], expr	Z	6F	8	2	RRC [X+expr]	C, Z
16	9	3	SUB [expr], expr	C, Z	43	9	3	OR reg[expr], expr	Z	70	4	2	AND F, expr	C, Z
17	10	3	SUB [X+expr], expr	C, Z	44	10	3	OR reg[X+expr], expr	Z	71	4	2	OR F, expr	C, Z
18	5	1	POP A	Z	45	9	3	XOR reg[expr], expr	Z	72	4	2	XOR F, expr	C, Z
19	4	2	SBB A, expr	C, Z	46	10	3	XOR reg[X+expr], expr	Z	73	4	1	CPL A	Z
1A	6	2	SBB A, [expr]	C, Z	47	8	3	TST [expr], expr	Z	74	4	1	INC A	C, Z
1B	7	2	SBB A, [X+expr]	C, Z	48	9	3	TST [X+expr], expr	Z	75	4	1	INC X	C, Z
1C	7	2	SBB [expr], A	C, Z	49	9	3	TST reg[expr], expr	Z	76	7	2	INC [expr]	C, Z
1D	8	2	SBB [X+expr], A	C, Z	4A	10	3	TST reg[X+expr], expr	Z	77	8	2	INC [X+expr]	C, Z
1E	9	3	SBB [expr], expr	C, Z	4B	5	1	SWAP A, X	Z	78	4	1	DEC A	C, Z
1F	10	3	SBB [X+expr], expr	C, Z	4C	7	2	SWAP A, [expr]	Z	79	4	1	DEC X	C, Z
20	5	1	POP X		4D	7	2	SWAP X, [expr]		7A	7	2	DEC [expr]	C, Z
21	4	2	AND A, expr	Z	4E	5	1	SWAP A, SP	Z	7B	8	2	DEC [X+expr]	C, Z
22	6	2	AND A, [expr]	Z	4F	4	1	MOV X, SP		7C	13	3	LCALL	
23	7	2	AND A, [X+expr]	Z	50	4	2	MOV A, expr	Z	7D	7	3	LJMP	
24	7	2	AND [expr], A	Z	51	5	2	MOV A, [expr]	Z	7E	10	1	RETI	C, Z
25	8	2	AND [X+expr], A	Z	52	6	2	MOV A, [X+expr]	Z	7F	8	1	RET	
26	9	3	AND [expr], expr	Z	53	5	2	MOV [expr], A		8x	5	2	JMP	
27	10	3	AND [X+expr], expr	Z	54	6	2	MOV [X+expr], A		9x	11	2	CALL	
28	11	1	ROMX	Z	55	8	3	MOV [expr], expr		Ax	5	2	JZ	
29	4	2	OR A, expr	Z	56	9	3	MOV [X+expr], expr		Bx	5	2	JNZ	
2A	6	2	OR A, [expr]	Z	57	4	2	MOV X, expr		Cx	5	2	JC	
2B	7	2	OR A, [X+expr]	Z	58	6	2	MOV X, [expr]		Dx	5	2	JNC	
2C	7	2	OR [expr], A	Z	59	7	2	MOV X, [X+expr]		Ex	7	2	JACC	
										Fx	13	2	INDEX	Z

**Notes**

1. Interrupt routines take 13 cycles before execution resumes at interrupt vector table.
2. The number of cycles required by an instruction is increased by one for instructions that span 256-byte boundaries in the Flash memory space.

### Memory Organization

#### Flash Program Memory Organization

Figure 8. Program Memory Space with Interrupt Vector Table

Address	Description
0x0000	Program execution begins here after a reset
0x0004	POR/LVD
0x0008	Reserved
0x000C	SPI Transmitter Empty
0x0010	SPI Receiver Full
0x0014	GPIO Port 0
0x0018	GPIO Port 1
0x001C	INT1
0x0020	Reserved
0x0024	Reserved
0x0028	Reserved
0x002C	Reserved
0x0030	Reserved
0x0034	1 ms Interval Timer
0x0038	Programmable Interval Timer
0x003C	Reserved
0x0040	Reserved
0x0044	16-bit Free Running Timer Wrap
0x0048	INT2
0x004C	Reserved
0x0050	GPIO Port 2
0x0054	Reserved
0x0058	Reserved
0x005C	Reserved
0x0060	Reserved
0x0064	Sleep Timer
0x0068	<b>Program Memory begins here (if below interrupts not used, program memory can start lower)</b>
0x1FFF	

Diagram description: A box labeled 'after reset' and '16-bit PC' has an arrow pointing to the '0x0000' address in the table.

### Data Memory Organization

The MCU function provides up to 256 bytes of data RAM.

Figure 9. Data Memory Organization

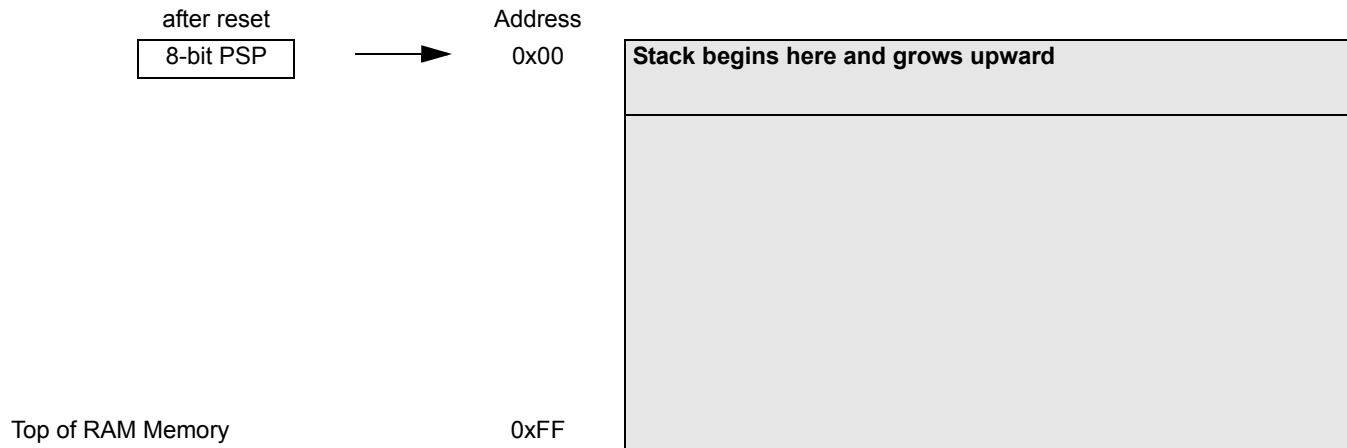

### Flash

This section describes the Flash block of the CYRF69103. Much of the user visible Flash functionality, including programming and security, are implemented in the M8C Supervisory Read Only Memory (SROM). CYRF69103 Flash has an endurance of 1000 cycles and 10-year data retention.

#### Flash Programming and Security

All Flash programming is performed by code in the SROM. The registers that control the Flash programming are only visible to the M8C CPU when it is executing out of SROM. This makes it impossible to read, write, or erase the Flash by bypassing the security mechanisms implemented in the SROM.

Customer firmware can only program the Flash through SROM calls. The data or code images can be sourced by way of any interface with the appropriate support firmware. This type of programming requires a 'bootloader' – a piece of firmware resident on the Flash. For safety reasons, this bootloader must not be over written during firmware rewrites.

The Flash provides four auxiliary rows that are used to hold Flash block protection flags, boot time calibration values, configuration tables, and any device values. The routines for accessing these auxiliary rows are documented in the SROM section. The auxiliary rows are not affected by the device erase function.

#### In-System Programming

CYRF69103 enables this type of in-system programming by using the P1.0 and P1.1 pins as the serial programming mode interface. This allows an external controller to cause the CYRF69103 to enter serial programming mode and then to use the test queue to issue Flash access functions in the SROM.

### SROM

The SROM holds code that is used to boot the part, calibrate circuitry, and perform Flash operations (Table 23 lists the SROM functions). The functions of the SROM may be accessed in normal user code or operating from Flash. The SROM exists in a separate memory space from user code. The SROM functions are accessed by executing the Supervisory System Call instruction (SSC), which has an opcode of 00h. Before executing the SSC, the M8C's accumulator needs to be loaded with the desired SROM function code from Table 23. Undefined functions causes a HALT if called from user code. The SROM functions are executing code with calls; therefore, the functions require stack space. With the exception of Reset, all of the SROM functions have a *parameter block* in SRAM that must be configured before executing the SSC. Table 24 on page 22 lists all possible parameter block variables. The meaning of each parameter, with regards to a specific SROM function, is described later in this section.

Table 23. SROM Function Codes

Function Code	Function Name	Stack Space
00h	SWBootReset	0
01h	ReadBlock	7
02h	WriteBlock	10
03h	EraseBlock	9
05h	EraseAll	11
06h	TableRead	3
07h	CheckSum	3

Two important variables that are used for all functions are KEY1 and KEY2. These variables are used to help discriminate between valid SSCs and inadvertent SSCs. KEY1 must always have a value of 3Ah, while KEY2 must have the same value as the stack pointer when the SROM function begins execution. This is the Stack Pointer value when the SSC opcode is executed, plus three. If either of the keys do not match the expected values, the M8C halts (with the exception of the SWBootReset function). The following code puts the correct value in KEY1 and KEY2. The code starts with a halt, to force the program to jump directly into the setup code and not run into it.

```
halt
SSCOP: mov [KEY1], 3ah
mov X, SP
mov A, X
add A, 3
mov [KEY2], A
```

**Table 24. SROM Function Parameters**

Variable Name	SRAM Address
Key1/Counter/Return Code	0,F8h
Key2/TMP	0,F9h
BlockID	0,FAh
Pointer	0,FBh
Clock	0,FCCh
Mode	0,FDh
Delay	0,FEh
PCL	0,FFh

The SROM also features Return Codes and Lockouts.

#### Return Codes

Return codes aid in the determination of success or failure of a particular function. The return code is stored in KEY1's position in the parameter block. The CheckSum and TableRead functions do not have return codes because KEY1's position in the parameter block is used to return other data.

**Table 25. SROM Return Codes**

Return Code	Description
00h	Success
01h	Function not allowed due to level of protection on block
02h	Software reset without hardware reset
03h	Fatal error, SROM halted

Read, write, and erase operations may fail if the target block is read or write protected. Block protection levels are set during device programming.

The EraseAll function overwrites data in addition to leaving the entire user Flash in the erase state. The EraseAll function loops through the number of Flash macros in the product, executing the following sequence: erase, bulk program all zeros, erase. After all the user space in all the Flash macros are erased, a second loop erases and then programs each protection block with zeros.

## SROM Function Descriptions

All SROM functions are described in the following sections.

### SWBootReset Function

The SROM function, SWBootReset, is the function that is responsible for transitioning the device from a reset state to running user code. The SWBootReset function is executed whenever the SROM is entered with an M8C accumulator value of 00h; the SRAM parameter block is not used as an input to the function. This happens, by design, after a hardware reset, because the M8C's accumulator is reset to 00h or when user code executes the SSC instruction with an accumulator value of 00h. The SWBootReset function does not execute when the SSC instruction is executed with a bad key value and a nonzero function code. A CYRF69103 device executes the HALT instruction if a bad value is given for either KEY1 or KEY2.

The SWBootReset function verifies the integrity of the calibration data by way of a 16-bit checksum, before releasing the M8C to run user code.

### ReadBlock Function

The ReadBlock function is used to read 64 contiguous bytes from Flash – a block.

The first thing this function does is to check the protection bits and determine if the desired BLOCKID is readable. If read protection is turned on, the ReadBlock function exits setting the accumulator and KEY2 back to 00h. KEY1 has a value of 01h, indicating a read failure. If read protection is not enabled, the function reads 64 bytes from the Flash using a ROMX instruction and store the results in SRAM using an MVI instruction. The first of the 64 bytes are stored in SRAM at the address indicated by the value of the POINTER parameter. When the ReadBlock completes successfully, the accumulator, KEY1 and KEY2, all have a value of 00h.

**Table 26. ReadBlock Parameters**

Name	Address	Description
KEY1	0,F8h	3Ah
KEY2	0,F9h	Stack Pointer value, when SSC is executed
BLOCKID	0,FAh	Flash block number
POINTER	0,FBh	First of 64 addresses in SRAM where returned data must be stored

### WriteBlock Function

The WriteBlock function is used to store data in the Flash. Data is moved 64 bytes at a time from SRAM to Flash using this function. The first thing the WriteBlock function does is to check the protection bits and determine if the desired BLOCKID is writable. If write protection is turned on, the WriteBlock function exits, setting the accumulator and KEY2 back to 00h. KEY1 has a value of 01h, indicating a write failure. The configuration of the WriteBlock function is straightforward. The BLOCKID of the Flash block, where the data is stored, must be determined and stored at SRAM address FAh.

The SRAM address of the first of the 64 bytes to be stored in Flash must be indicated using the POINTER variable in the

parameter block (SRAM address FBh). Finally, the CLOCK and DELAY values must be set correctly. The CLOCK value determines the length of the write pulse that is used to store the data in the Flash. The CLOCK and DELAY values are dependent on the CPU. Refer to 'Clocking' Section for additional information.

**Table 27. WriteBlock Parameters**

Name	Address	Description
KEY1	0,F8h	3Ah
KEY2	0,F9h	Stack Pointer value, when SSC is executing
BLOCK ID	0,FAh	8 KB Flash block number (00h–7Fh) 4 KB Flash block number (00h–3Fh) 3 KB Flash block number (00h–2Fh)
POINTER	0,FBh	First 64 addresses in SRAM where the data to be stored in Flash is located before calling WriteBlock
CLOCK	0,FCh	Clock Divider used to set the write Pulse width
DELAY	0,FEh	For a CPU speed of 12 MHz set to 56h

*EraseBlock Function*

The EraseBlock function is used to erase a block of 64 contiguous bytes in Flash. The first thing the EraseBlock function does is to check the protection bits and determine if the desired BLOCKID is writable. If write protection is turned on, the EraseBlock function exits, setting the accumulator and KEY2 back to 00h. KEY1 has a value of 01h, indicating a write failure. The EraseBlock function is only useful as the first step in programming. Erasing a block does not cause data in a block to be one hundred percent unreadable. If the objective is to obliterate data in a block, the best method is to perform an EraseBlock followed by a WriteBlock of all zeros.

To set up the parameter block for the EraseBlock function, correct key values must be stored in KEY1 and KEY2. The block number to be erased must be stored in the BLOCKID variable and the CLOCK and DELAY values must be set based on the current CPU speed.

**Table 28. EraseBlock Parameters**

Name	Address	Description
KEY1	0,F8h	3Ah
KEY2	0,F9h	Stack Pointer value when SSC is executed
BLOCKID	0,FAh	Flash block number (00h–7Fh)
CLOCK	0,FCh	Clock Divider used to set the erase pulse width
DELAY	0,FEh	For a CPU speed of 12 MHz set to 56h

*ProtectBlock Function*

The CYRF69103 device offers Flash protection on a block-by-block basis. Table 29 lists the protection modes

available. In the table, ER and EW are used to indicate the ability to perform external reads and writes. For internal writes, IW is used. Internal reading is always permitted by way of the ROMX instruction. The ability to read by way of the SRAM ReadBlock function is indicated by SR. The protection level is stored in two bits, according to Table 29. These bits are bit packed into the 64 bytes of the protection block. Therefore, each protection block byte stores the protection level for four Flash blocks. The bits are packed into a byte, with the lowest numbered block's protection level stored in the lowest numbered bits.

The first address of the protection block contains the protection level for blocks 0 through 3; the second address is for blocks 4 through 7. The 64th byte stores the protection level for blocks 252 through 255.

**Table 29. Protection Modes**

Mode	Settings	Description	Marketing
00b	SR ER EW IW	Unprotected	Unprotected
01b	SR ER EW IW	Read protect	Factory upgrade
10b	SR ER EW IW	Disable external write	Field upgrade
11b	SR ER EW IW	Disable internal write	Full protection

7	6	5	4	3	2	1	0
Block n+3		Block n+2		Block n+1		Block n	

The level of protection is only decreased by an EraseAll, which places zeros in all locations of the protection block. To set the level of protection, the ProtectBlock function is used. This function takes data from SRAM, starting at address 80h, and ORs it with the current values in the protection block. The result of the OR operation is then stored in the protection block. The EraseBlock function does not change the protection level for a block. Because the SRAM location for the protection data is fixed and there is only one protection block per Flash macro, the ProtectBlock function expects very few variables in the parameter block to be set before calling the function. The parameter block values that must be set, besides the keys, are the CLOCK and DELAY values.

**Table 30. ProtectBlock Parameters**

Name	Address	Description
KEY1	0,F8h	3Ah
KEY2	0,F9h	Stack Pointer value when SSC is executed
CLOCK	0,FCh	Clock Divider used to set the write pulse width
DELAY	0,FEh	For a CPU speed of 12 MHz set to 56h

*EraseAll Function*

The EraseAll function performs a series of steps that destroy the user data in the Flash macros and resets the protection block in each Flash macro to all zeros (the unprotected state). The EraseAll function does not affect the three hidden blocks above



the protection block in each Flash macro. The first of these four hidden blocks is used to store the protection table for its eight Kbytes of user data.

The EraseAll function begins by erasing the user space of the Flash macro with the highest address range. A bulk program of all zeros is then performed on the same Flash macro, to destroy all traces of the previous contents. The bulk program is followed by a second erase that leaves the Flash macro in a state ready for writing. The erase, program, erase sequence is then performed on the next lowest Flash macro in the address space if it exists. Following the erase of the user space, the protection block for the Flash macro with the highest address range is erased. Following the erase of the protection block, zeros are written into every bit of the protection table. The next lowest Flash macro in the address space then has its protection block erased and filled with zeros.

The end result of the EraseAll function is that all user data in the Flash is destroyed and the Flash is left in an unprogrammed state, ready to accept one of the various write commands. The protection bits for all user data are also reset to the zero state.

The parameter block values that must be set, besides the keys, are the CLOCK and DELAY values.

**Table 31. EraseAll Parameters**

Name	Address	Description
KEY1	0,F8h	3Ah
KEY2	0,F9h	Stack Pointer value when SSC is executed
CLOCK	0,FCh	Clock Divider used to set the write pulse width
DELAY	0,FEh	For a CPU speed of 12 MHz set to 56h

#### TableRead Function

The TableRead function gives the user access to part specific data stored in the Flash during manufacturing. It also returns a Revision ID for the die (not to be confused with the Silicon ID).

**Table 32. Table Read Parameters**

Name	Address	Description
KEY1	0,F8h	3Ah
KEY2	0,F9h	Stack Pointer value when SSC is executed
BLOCKID	0,FAh	Table number to read

The table space for the CYRF69103 is simply a 64 byte row broken up into eight tables of eight bytes. The tables are

numbered zero through seven. All user and hidden blocks in the CYRF69103 consist of 64 bytes.

An internal table holds the Silicon ID and returns the Revision ID. The Silicon ID is returned in SRAM, while the Revision ID is returned in the CPU\_A and CPU\_X registers. The Silicon ID is a value placed in the table by programming the Flash and is controlled by Cypress Semiconductor Product Engineering. The Revision ID is hard coded into the SROM. The Revision ID is discussed in more detail later in this section.

An internal table holds alternate trim values for the device and returns a one-byte internal revision counter. The internal revision counter starts out with a value of zero and is incremented each time one of the other revision numbers is not incremented. It is reset to zero each time one of the other revision numbers is incremented. The internal revision count is returned in the CPU\_A register. The CPU\_X register is always set to FFh when trim values are read. The BLOCKID value, in the parameter block, is used to indicate which table must be returned to the user. Only the three least significant bits of the BLOCKID parameter are used by the TableRead function for the CYRF69103. The upper five bits are ignored. When the function is called, it transfers bytes from the table to SRAM addresses F8h–FFh.

The M8C's A and X registers are used by the TableRead function to return the die's Revision ID. The Revision ID is a 16-bit value hard coded into the SROM that uniquely identifies the die's design.

#### Checksum Function

The Checksum function calculates a 16-bit checksum over a user specifiable number of blocks, within a single Flash macro (Bank) starting from block zero. The BLOCKID parameter is used to pass in the number of blocks to calculate the checksum over. A BLOCKID value of 1 calculates the checksum of only block 0, while a BLOCKID value of 0 calculates the checksum of all 256 user blocks. The 16-bit checksum is returned in KEY1 and KEY2. The parameter KEY1 holds the lower eight bits of the checksum and the parameter KEY2 holds the upper eight bits of the checksum.

The checksum algorithm executes the following sequence of three instructions over the number of blocks times 64 to be checksummed.

```
romx
add [KEY1], A
adc [KEY2], 0
```

**Table 33. Checksum Parameters**

Name	Address	Description
KEY1	0,F8h	3Ah
KEY2	0,F9h	Stack Pointer value when SSC is executed
BLOCKID	0,FAh	Number of Flash blocks to calculate checksum on

### Clocking

The CYRF69103 internal oscillator outputs two frequencies, the Internal 24 MHz Oscillator and the 32 kHz Low power Oscillator.

The Internal 24 MHz Oscillator is designed such that it may be trimmed to an output frequency of 24 MHz over temperature and voltage variation. The Internal 24 MHz Oscillator accuracy is 24 MHz -22% to +10% (between 0 °C-70 °C). No external components are required to achieve this level of accuracy.

Firmware is responsible for selecting the correct trim values from the User row to match the power supply voltage in the end application and writing the values to the trim registers IOSCTR and LPOSCTR.

The internal low speed oscillator of nominally 32 kHz provides a slow clock source for the CYRF69103 in suspend mode. This is used to generate a periodic wakeup interrupt and provide a clock to sequential logic during power up and power down events when the main clock is stopped. In addition, this oscillator can

also be used as a clocking source for the Interval Timer clock (ITMRCLK) and Capture Timer clock (TCAPCLK). The 32 kHz Low power Oscillator can operate in low power mode or can provide a more accurate clock in normal mode. The Internal 32 kHz Low power Oscillator accuracy ranges from -53.12% to +56.25%. The 32 kHz low power oscillator can be calibrated against the internal 24 MHz oscillator or another timing source if desired.

CYRF69103 provides the ability to load new trim values for the 24 MHz oscillator based on voltage. This allows Vdd to be monitored and have firmware trim the oscillator based on voltage present. The IOSCTR register is used to set trim values for the 24 MHz oscillator. CYRF69103 is initialized with 3.30V trim values at power on, then firmware is responsible for transferring the correct set of trim values to the trim registers to match the application's actual Vdd. The 32 kHz oscillator generally does not require trim adjustments versus voltage but trim values for the 32 kHz are also stored in Supervisory ROM.

Figure 10. SROM Table

	F8h	F9h	FAh	FBh	FCh	FDh	FEh	FFh
Table 0	Silicon ID [15-8]	Silicon ID [7-0]						
Table 1								
Table 2					24 MHz IOSCTR at 3.30V	24 MHz IOSCTR at 3.00V	24 MHz IOSCTR at 2.85V	24 MHz IOSCTR at 2.70V
Table 3	32 kHz LPOSCTR at 3.30V	32 kHz LPOSCTR at 3.00V	32 kHz LPOSCTR at 2.85V	32 kHz LPOSCTR at 2.70V				
Table 4								
Table 5								
Table 6								
Table 7								

To improve the accuracy of the IMO, new trim values are loaded based on supply voltage to the part. For this, firmware needs to make modifications to two registers:

1. The internal oscillator trim register at location 0x34.
2. The gain register at location 0x38.