



Chipsmall Limited consists of a professional team with an average of over 10 year of expertise in the distribution of electronic components. Based in Hongkong, we have already established firm and mutual-benefit business relationships with customers from,Europe,America and south Asia,supplying obsolete and hard-to-find components to meet their specific needs.

With the principle of “Quality Parts,Customers Priority,Honest Operation,and Considerate Service”,our business mainly focus on the distribution of electronic components. Line cards we deal with include Microchip,ALPS,ROHM,Xilinx,Pulse,ON,Everlight and Freescale. Main products comprise IC,Modules,Potentiometer,IC Socket,Relay,Connector.Our parts cover such applications as commercial,industrial, and automotives areas.

We are looking forward to setting up business relationship with you and hope to provide you with the best service and solution. Let us make a better world for our industry!



Contact us

Tel: +86-755-8981 8866 Fax: +86-755-8427 6832

Email & Skype: info@chipsmall.com Web: www.chipsmall.com

Address: A1208, Overseas Decoration Building, #122 Zhenhua RD., Futian, Shenzhen, China



Features

- SONET OC-48 operation
- Bellcore and ITU jitter compliance
- 2.488 GBaud serial signaling rate
- Multiple selectable loopback or loop through modes
- Single 155.52 MHz reference clock
- Transmit FIFO for flexible data interface clocking
- 16-bit parallel-to-serial conversion in transmit path
- Serial-to-16-bit parallel conversion in receive path
- Synchronous parallel interface
 - LVPECL compliant
 - HSTL compliant
- Internal transmit and receive phase-locked loops (PLLs)
- Differential CML serial input
 - 50 mV input sensitivity
 - 100 Ω internal termination and DC restoration
- Differential CML serial output
 - Source matched for 50 Ω transmission lines (100 Ω differential transmission lines)
- Direct interface to standard fiber optic modules
- Less than 1.0W typical power
- 120-pin 14 mm \times 14 mm TQFP
- Standby power saving mode for inactive loops
- 0.25 μ BiCMOS technology
- Pb-free packages available

Functional Description

The CYS25G0101DX SONET OC-48 Transceiver is a communications building block for high speed SONET data communications. It provides complete parallel-to-serial and serial-to-parallel conversion, clock generation, and clock and data recovery operations in a single chip optimized for full SONET compliance.

Transmit Path

New data is accepted at the 16-bit parallel transmit interface at a rate of 155.52 MHz. This data is passed to a small integrated FIFO to enable flexible transfer of data between the SONET processor and the transmit serializer. As each 16-bit word is read from the transmit FIFO, it is serialized and sent out to the high speed differential line driver at a rate of 2.488 Gbits per second.

Receive Path

As serial data is received at the differential line receiver, it is passed to a clock and data recovery (CDR) PLL that extracts a precision low jitter clock from the transitions in the data stream. This bit rate clock is used to sample the data stream and receive the data. Every 16-bit times, a new word is presented at the receive parallel interface along with a clock.

Parallel Interface

The parallel I/O interface supports high speed bus communications using HSTL signaling levels to minimize both power consumption and board landscape. The HSTL outputs are capable of driving unterminated transmission lines of less than 70 mm and terminated 50 Ω transmission lines of more than twice that length.

The CYS25G0101DX Transceiver's parallel HSTL I/O can also be configured to operate at LVPECL signaling levels. This is done externally by changing V_{DDQ} , V_{REF} and creating a simple circuit at the termination of the transceiver's parallel output interface.

Logic Block Diagram

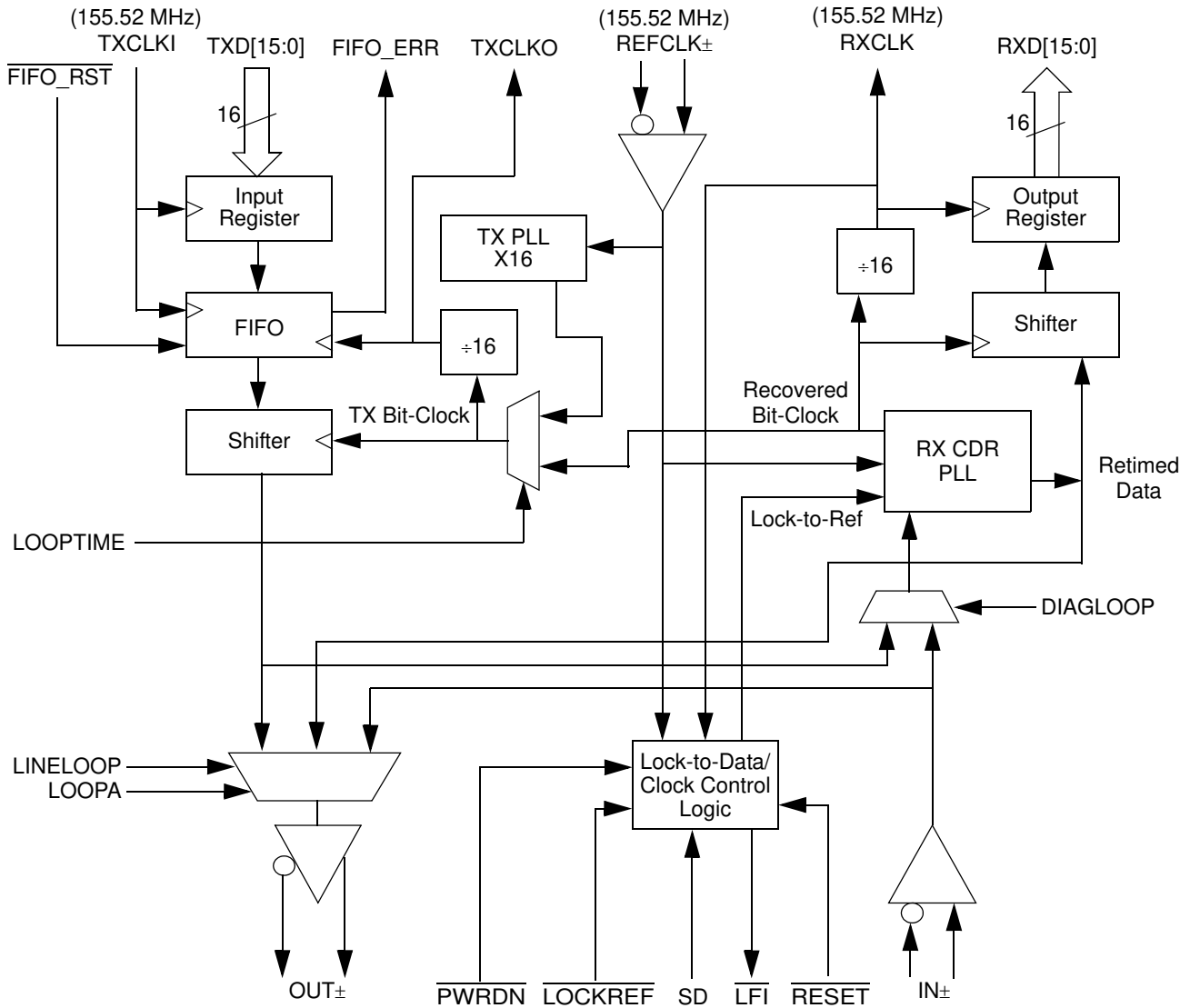

Contents

Clocking	4	DC Specifications	10
Pin Configuration	5	DC Specifications	10
Pin Descriptions	6	DC Specifications	11
CYS25G0101DX Operation	8	DC Specifications	11
CYS25G0101DX Transmit Data Path	8	DC Specifications	12
Operating Modes	8	AC Test Loads and Waveforms	12
Phase Align Buffer	8	AC Specifications	13
Transmit PLL Clock Multiplier	8	AC Specifications	13
Serializer	8	AC Specifications	14
Serial Output Driver	8	Jitter Specifications	14
CYS25G0101DX Receive Data Path	8	Jitter Waveforms	15
Serial Line Receivers	8	Switching Waveforms	16
Lock to Data Control	8	Typical IO Terminations	17
Clock Data Recovery	8	Ordering Information	19
External Filter	8	Ordering Code Definitions	19
Deserializer	9	Package Diagram	20
Loopback Timing Modes	9	Document History Page	21
Reset Modes	9	Sales, Solutions, and Legal Information	22
Power Down Mode	9	Worldwide Sales and Design Support	22
LVPECL Compliance	9	Products	22
Maximum Ratings	10	PSoC® Solutions	22
Power Up Requirements	10	Cypress Developer Community	22
Operating Range	10	Technical Support	22

Clocking

The source clock for the transmit data path is selectable from either the recovered clock or an external BITS (Building Integrated Timing Source) reference clock. The low jitter of the CDR PLL enables loop timed operation of the transmit data path meeting all Bellcore and ITU jitter requirements.

Multiple loopback and loop through modes are available for both diagnostic and normal operation. For systems containing redundant SONET rings that are maintained in standby, the CYS25G0101DX may also be dynamically powered down to conserve system power.

Figure 1. CYS25G0101DX System Connections

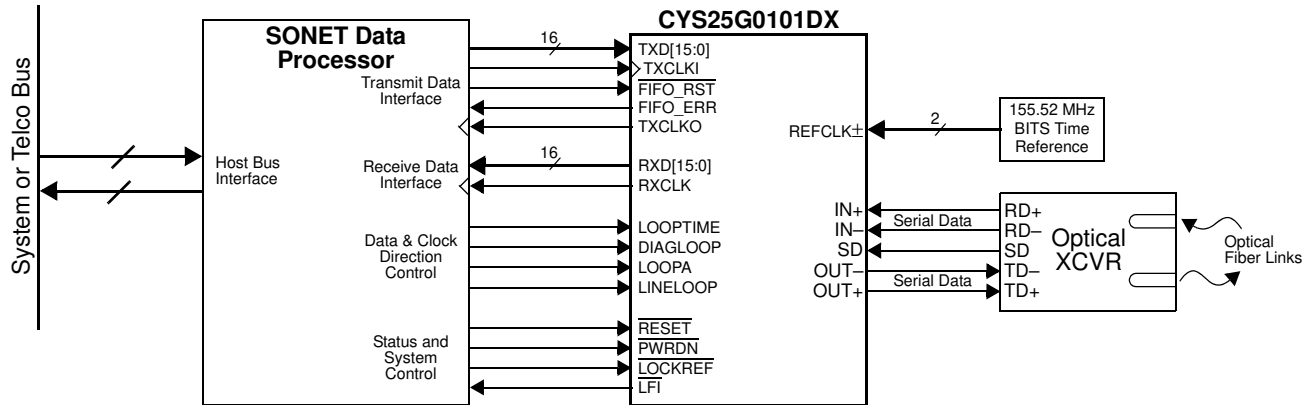

Pin Configuration

Figure 2. 120-pin TQFP pinout [1, 2]

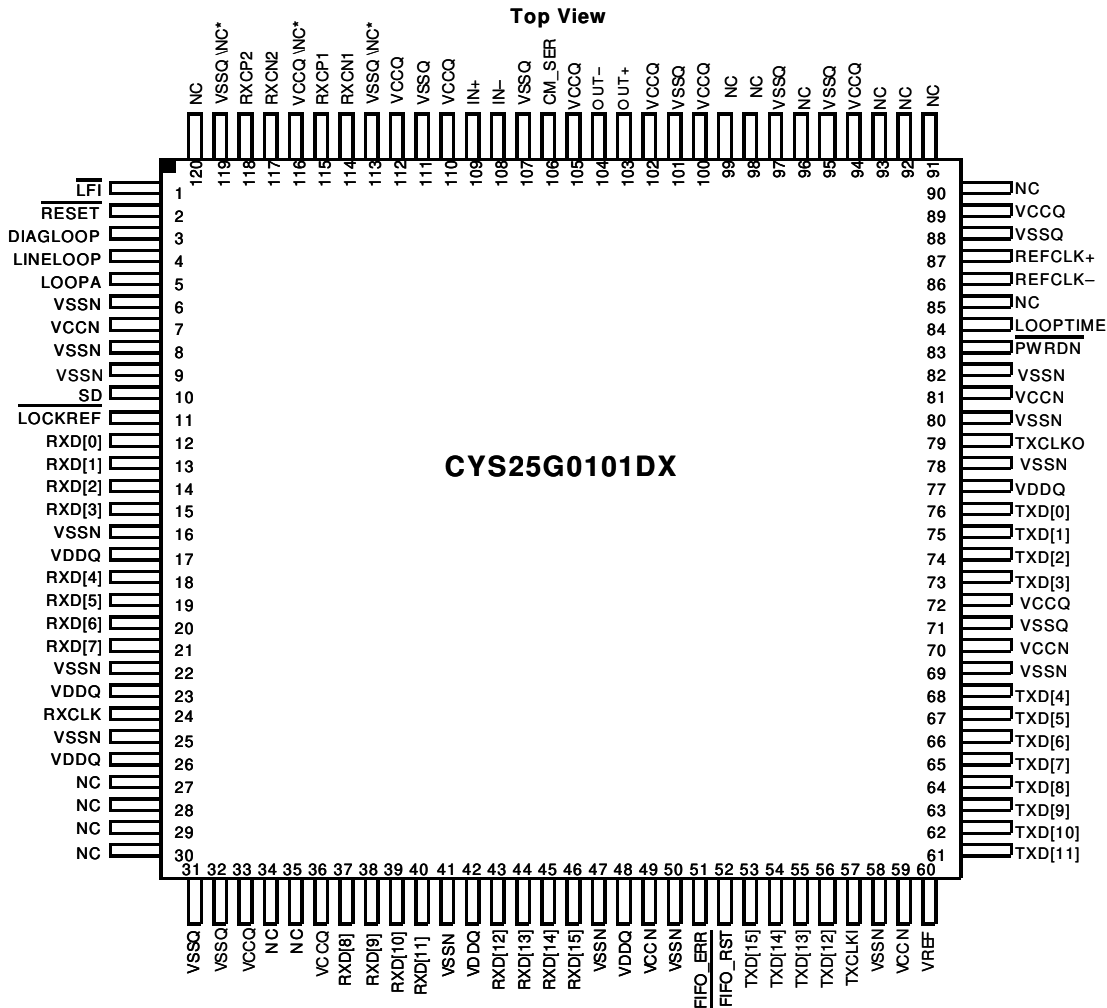

Notes

1. No connect (NC) pins are left unconnected or floating. Connecting any of these pins to the positive or negative power supply causes improper operation or failure of the device.
2. Pins 113 and 119 are either no connect or VSSQ. Use VSSQ for compatibility with next generation of OC-48 SERDES devices. Pin 116 are either no connect or VCCQ. Use VCCQ for compatibility with next generation of OC-48 SERDES devices.

Pin Descriptions

CYS25G0101DX OC-48 SONET Transceiver

Pin Name	I/O Characteristics	Signal Description
Transmit Path Signals		
TXD[15:0]	HSTL inputs, sampled by TXCLKI↑	Parallel Transmit Data Inputs. A 16-bit word, sampled by TXCLKI↑. TXD[15] is the most significant bit (the first bit transmitted).
TXCLKI	HSTL Clock input	Parallel Transmit Data Input Clock. The TXCLKI is used to transfer the data into the input register of the serializer. The TXCLKI samples the data, TXD [15:0], on the rising edge of the clock cycle.
TXCLKO	HSTL Clock output	Transmit Clock Output. Divide by 16 of the selected transmit bit rate clock. It is used to coordinate byte wide transfers between upstream logic and the CYS25G0101DX.
V _{REF}	Input Analog Reference	Reference Voltage for HSTL Parallel Input Bus. V _{DDQ} /2. ^[3]
Receive Path Signals		
RXD[15:0]	HSTL output, synchronous	Parallel Receive Data Output. These outputs change following RXCLK↓. RXD[15] is the most significant bit of the output word and is received first on the serial interface.
RXCLK	HSTL Clock output	Receive Clock Output. Divide by 16 of the bit rate clock extracted from the received serial stream. RXD [15:0] is clocked out on the falling edge of the RXCLK.
CM_SER	Analog	Common Mode Termination. Capacitor shunt to V _{SS} for common mode noise.
RXCN1	Analog	Receive Loop Filter Capacitor (Negative).
RXCN2	Analog	Receive Loop Filter Capacitor (Negative).
RXCP1	Analog	Receive Loop Filter Capacitor (Positive).
RXCP2	Analog	Receive Loop Filter Capacitor (Positive).
Device Control and Status Signals		
REFCLK±	Differential LVPECL input	Reference Clock. This clock input is used as the timing reference for the transmit and receive PLLs. A derivative of this input clock is used to clock the transmit parallel interface. The reference clock is internally biased enabling for an AC coupled clock signal.
LFI	LVTTTL output	Line Fault Indicator. When LOW, this signal indicates that the selected receive data stream is detected as invalid by either a LOW input on SD or by the receive VCO operated outside its specified limits.
RESET	LVTTTL input	Reset for all logic functions except the transmit FIFO.
LOCKREF	LVTTTL input	Receive PLL Lock to Reference. When LOW, the receive PLL locks to REFCLK instead of the received serial data stream.
SD	LVTTTL input	Signal Detect. When LOW, the receive PLL locks to REFCLK instead of the received serial data stream. The SD needs to be connected to an external optical module to indicate a loss of received optical power.
FIFO_ERR	LVTTTL output	Transmit FIFO Error. When HIGH, the transmit FIFO has either underflowed or overflowed. When this occurs, the FIFO's internal clearing mechanism clears the FIFO within nine clock cycles. In addition, FIFO_RST is activated at device power up to ensure that the in and out pointers of the FIFO are set to maximum separation.
FIFO_RST	LVTTTL input	Transmit FIFO Reset. When LOW, the in and out pointers of the transmit FIFO are set to maximum separation. FIFO_RST is activated at device power up to ensure that the in and out pointers of the FIFO are set to maximum separation. When the FIFO is reset, the output data is a 1010... pattern.
PWRDN	LVTTTL input	Device Power Down. When LOW, the logic and drivers are all disabled and placed into a standby condition where only minimal power is dissipated.

Note

3. V_{REF} equals to (V_{CC} – 1.33V) if interfacing to a parallel LVPECL interface.

Pin Descriptions (continued)

CYS25G0101DX OC-48 SONET Transceiver

Pin Name	I/O Characteristics	Signal Description
Loop Control Signals		
DIAGLOOP	LVTTL input	Diagnostic Loopback Control. When HIGH, transmit data is routed through the receive clock and data recovery. It is then presented at the RXD[15:0] outputs. When LOW, received serial data is routed through the receive clock and data recovery. It is then presented at the RXD[15:0] outputs.
LINELOOP	LVTTL input	Line Loopback Control. When HIGH, received serial data is looped back from receive to transmit after being reclocked by a recovered clock. When LINELOOP is LOW, the data passed to the OUT± line driver is controlled by LOOPA. When both LINELOOP and LOOPA are LOW, the data passed to the OUT± line driver is generated in the transmit shifter.
LOOPA	LVTTL input	Analog Line Loopback. When LINELOOP is LOW and LOOPA is HIGH, received serial data is looped back from receive input buffer to transmit output buffer but is not routed through the clock and data recovery PLL. When LOOPA is LOW, the data passed to the OUT± line driver is controlled by LINELOOP.
LOOPTIME	LVTTL input	Loop Time Mode. When HIGH, the extracted receive bit clock replaces transmit bit clock. When LOW, the REFCLK input is multiplied by 16 to generate the transmit bit clock.
Serial I/O		
OUT±	Differential CML output	Differential Serial Data Output. This differential CML output (+3.3 V referenced) is capable of driving terminated 50Ω transmission lines or commercial fiber optic transmitter modules.
IN±	Differential CML input	Differential Serial Data Input. This differential input accepts the serial data stream for deserialization and clock extraction.
Power		
V _{CCN}	Power	+3.3 V supply (for digital and low speed IO functions)
V _{SSN}	Ground	Signal and power ground (for digital and low speed IO functions)
V _{CCQ}	Power	+3.3 V quiet power (for analog functions)
V _{SSQ}	Ground	Quiet ground (for analog functions)
V _{DDQ}	Power	+1.5 V supply for HSTL outputs ^[4]

Note

 4. V_{DDQ} equals V_{CC} if interfacing to a parallel LVPECL interface.

CYS25G0101DX Operation

The CYS25G0101DX is a highly configurable device designed to support reliable transfer of large quantities of data using high speed serial links. It performs necessary clock and data recovery, clock generation, serial-to-parallel conversion, and parallel-to-serial conversion. CYS25G0101DX also provides various loopback functions.

CYS25G0101DX Transmit Data Path

Operating Modes

The transmit path of the CYS25G0101DX supports 16-bit wide data paths.

Phase Align Buffer

Data from the input register is passed to a phase align buffer (FIFO). This buffer is used to absorb clock phase differences between the transmit input clock and the internal character clock.

Initialization of the phase align buffer takes place when the FIFO_RST input is asserted LOW. When FIFO_RST is returned HIGH, the present input clock phase, relative to TXCLKO, is set. Once set, the input clock is enabled to skew in time up to half a character period in either direction relative to REFCLK (that is, $\pm 180^\circ$). This time shift enables the delay path of the character clock (relative to REFCLK) to change due to operating voltage and temperature not affecting the desired operation. FIFO_RST is an asynchronous input. FIFO_ERR is the transmit FIFO Error indicator. When HIGH, the transmit FIFO has either underflowed or overflowed. The FIFO is externally reset to clear the error indication; or if no action is taken, the internal clearing mechanism clears the FIFO in nine clock cycles. When the FIFO is being reset, the output data is 1010.

Transmit PLL Clock Multiplier

The Transmit PLL Clock Multiplier accepts a 155.52 MHz external clock at the REFCLK input. It multiplies that clock by 16 to generate a bit rate clock for use by the transmit shifter. The operating serial signaling rate and allowable range of REFCLK frequencies is listed in [Table on page 13](#). The REFCLK phase noise limits to meet SONET compliancy are shown in [Figure 8 on page 15](#). The REFCLK \pm input is a standard LVPECL input.

Serializer

The parallel data from the phase align buffer is passed to the Serializer that converts the parallel data to serial data. It uses the bit rate clock generated by the Transmit PLL clock multiplier. TXD[15] is the most significant bit of the output word and is transmitted first on the serial interface.

Serial Output Driver

The Serial Interface Output Driver makes use of high performance differential Current Mode Logic (CML) to provide a source matched driver for the transmission lines. This driver receives its data from the Transmit Shifters or the receive loopback data. The outputs have signal swings equivalent to that of standard LVPECL drivers and are capable of driving AC coupled optical modules or transmission lines.

CYS25G0101DX Receive Data Path

Serial Line Receivers

A differential line receiver, IN \pm , is available for accepting the input serial data stream. The serial line receiver inputs accommodate high wire interconnect and filtering losses or transmission line attenuation ($V_{SE} \geq 25$ mV, or 50 mV peak-to-peak differential). It can be AC coupled to +3.3V or +5V powered fiber optic interface modules. The common mode tolerance of these line receivers accommodates a wide range of signal termination voltages.

Lock to Data Control

Line Receiver routed to the clock and data recovery PLL is monitored for:

- status of signal detect (SD) pin
- status of LOCKREF pin.

This status is presented on the Line Fault Indicator (LFI) output, that changes asynchronously in the cases in which SD or LOCKREF go from HIGH to LOW. Otherwise, it changes synchronously to the REFCLK.

Clock Data Recovery

The extraction of a bit rate clock and recovery of data bits from received serial stream is performed by a Clock Data Recovery (CDR) block. The clock extraction function is performed by high performance embedded phase-locked loop (PLL) that tracks the frequency of the incoming bit stream and aligns the phase of the internal bit rate clock to the transitions in the selected serial data stream.

CDR accepts a character rate (bit rate * 16) reference clock on the REFCLK input. This REFCLK input is used to ensure that the VCO (within the CDR) is operating at the correct frequency (rather than some harmonic of the bit rate), to improve PLL acquisition time and to limit unlocked frequency excursions of the CDR VCO when no data is present at the serial inputs.

Regardless of the type of signal present, the CDR attempts to recover a data stream from it. If the frequency of the recovered data stream is outside the limits set by the range controls, the CDR PLL tracks REFCLK instead of the data stream. When the frequency of the selected data stream returns to a valid frequency, the CDR PLL is allowed to track the received data stream. The frequency of REFCLK must be within ± 100 ppm of the frequency of the clock that drives the REFCLK signal of the remote transmitter to ensure a lock to the incoming data stream.

For systems using multiple or redundant connections, the LFI output can be used to select an alternate data stream. When an LFI indication is detected, external logic toggles selection of the input device. When such a port switch takes place, it is necessary for the PLL to reacquire lock to the new serial stream.

External Filter

The CDR circuit uses external capacitors for the PLL filter. A 0.1 μ F capacitor needs to be connected between RXCN1 and RXCP1. Similarly a 0.1 μ F capacitor needs to be connected between RXCN2 and RXCP2. The recommended packages and dielectric material for these capacitors are 0805 X7R or 0603 X7R.

Deserializer

The CDR circuit extracts bits from the serial data stream and clocks these bits into the Deserializer at the bit clock rate. The Deserializer converts serial data into parallel data. RXD[15] is the most significant bit of the output word and is received first on the serial interface.

Loopback Timing Modes

CYS25G0101DX supports various loopback modes, as described in the following sections.

Facility Loopback (Line Loopback with Retiming)

When the LINELOOP signal is set HIGH, the Facility Loopback mode is activated and the high speed serial receive data (IN \pm) is presented to the high speed transmit output (OUT \pm) after retiming. In Facility Loopback mode, the high speed receive data (IN \pm) is also converted to parallel data and presented to the low speed receive data output pins (RXD[15:0]). The receive recovered clock is also divided down and presented to the low speed clock output (RXCLK).

Equipment Loopback (Diagnostic Loopback with Retiming)

When the DIAGLOOP signal is set HIGH, transmit data is looped back to the RX PLL, replacing IN \pm . Data is looped back from the parallel TX inputs to the parallel RX outputs. The data is looped back at the internal serial interface and goes through transmit shifter and the receive CDR. SD is ignored in this mode.

Line Loopback Mode (Non-retimed Data)

When the LOOPA signal is set HIGH, the RX serial data is directly buffered out to the transmit serial data. The data at the serial output is not retimed.

Loop Timing Mode

When the LOOPTIME signal is set HIGH, the TX PLL is bypassed and the receive bit rate clock is used for the transmit side shifter.

Reset Modes

ALL logic circuits in the device are reset using $\overline{\text{RESET}}$ and FIFO_RST signals. When $\overline{\text{RESET}}$ is set LOW, all logic circuits except FIFO are internally reset. When FIFO_RST is set LOW, the FIFO logic is reset.

Power Down Mode

CYS25G0101DX provides a global power down signal PWRDN. When LOW, this signal powers down the entire device to a minimal power dissipation state. $\overline{\text{RESET}}$ and FIFO_RST signals should be asserted LOW along with PWRDN signal to ensure low power dissipation.

LVPECL Compliance

The CYS25G0101DX HSTL parallel I/O can be configured to LVPECL compliance with slight termination modifications. On the transmit side of the transceiver, the TXD[15:0] and TXCLKI are made LVPECL compliant by setting V_{REF} (reference voltage of a LVPECL signal) to $V_{\text{CC}} - 1.33 \text{ V}$. To emulate an LVPECL signal on the receiver side, set the VDDQ to 3.3 V and the transmission lines needs to be terminated with the Thévenin equivalent of Z_0 at LVPECL ref. The signal is then attenuated using a series resistor at the driver end of the line to reduce the 3.3 V swing level to a LVPECL swing level (see [Figure 14 on page 17](#)). This circuit needs to be used on all 16 RXD[15:0] pins, TXCLKO, and RXCLK. The voltage divider is calculated assuming the system is built with 50Ω transmission lines.

Maximum Ratings

Exceeding maximum ratings may shorten the useful life of the device. User guidelines are not tested.

- Storage Temperature -65 °C to +150 °C
- Ambient Temperature with Power Applied -55 °C to +125 °C
- V_{CC} Supply Voltage to Ground Potential -0.5 V to +4.2 V
- V_{DDQ} Supply Voltage to Ground Potential ... -0.5 V to +4.2 V
- DC Voltage Applied to HSTL Outputs in High Z State -0.5 V to V_{DDQ} + 0.5 V
- DC Voltage Applied to Other Outputs in High Z State -0.5 V to V_{CC} + 0.5 V
- Output Current into LVTTL Outputs (LOW) 30 mA
- DC Input Voltage -0.5 V to V_{CC} + 0.5 V
- Static Discharge Voltage (MIL-STD-883, Method 3015) > 1100 V

Latch up Current > 200 mA

Power Up Requirements

Power supply sequencing is not required if you are configuring V_{DDQ} = 3.3 V and all power supplies pins are connected to the same 3.3 V power supply.

Power supply sequencing is required if you are configuring V_{DDQ} = 1.5 V. Power is applied in the following sequence: V_{CC} (3.3) followed by V_{DDQ} (1.5). Power supply ramping may occur simultaneously as long as the V_{CC}/V_{DDQ} relationship is maintained.

Operating Range

Range	Ambient Temperature	V _{DDQ}	V _{CC}
Commercial	0 °C to +70 °C	1.4 V to 1.6 V ^[5]	3.3 V ± 10%
Industrial	-40 °C to +85 °C	1.4 V to 1.6 V ^[5]	3.3 V ± 10%

DC Specifications

LVTTL

Parameter	Description	Test Conditions	Min	Max	Unit
LVTTL Outputs					
V _{OHT}	Output HIGH Voltage	V _{CC} = Min, I _{OH} = -10.0 mA	2.4	-	V
V _{OLT}	Output LOW Voltage	V _{CC} = Min, I _{OL} = 10.0 mA	-	0.4	V
I _{OS}	Output Short Circuit Current	V _{OUT} = 0 V	-20	-90	mA
LVTTL Inputs					
V _{IHT}	Input HIGH Voltage	Low = 2.1 V, High = V _{CC} + 0.5 V	2.1	V _{CC} - 0.3	V
V _{ILT}	Input LOW Voltage	Low = -3.0 V, High = 0.8	-0.3	0.8	V
I _{IHT}	Input HIGH Current	V _{CC} = Max, V _{IN} = V _{CC}	-	50	µA
I _{ILT}	Input LOW Current	V _{CC} = Max, V _{IN} = 0 V	-	-50	µA
Capacitance					
C _{IN}	Input Capacitance	V _{CC} = Max, at f = 1 MHz	-	5	pF

DC Specifications

Power

Parameter	Description	Test Conditions	Typ	Max	Unit
Power					
I _{CC1}	Active Power Supply Current		300	347	mA
I _{SB}	Standby Current		-	5	mA

Note

5. V_{DDQ} equals V_{CC} if interfacing to a parallel LVPECL interface.

DC Specifications

Differential LVPECL Compatible Inputs (REFCLK) [6]

Parameter	Description	Test Conditions	Min	Max	Unit
V _{INSGLE}	Input Single-ended Swing		200	600	mV
V _{DIFFE}	Input Differential Voltage		400	1200	mV
V _{IEHH}	Highest Input HIGH Voltage		V _{CC} - 1.2	V _{CC} - 0.3	V
V _{IELL}	Lowest Input LOW Voltage		V _{CC} - 2.0	V _{CC} - 1.45	V
I _{IEH}	Input HIGH Current	V _{IN} = V _{IEHH} Max.	-	750	μA
I _{IEL}	Input LOW Current	V _{IN} = V _{IELL} Min.	-200	-	μA
Capacitance					
C _{INE}	Input Capacitance		-	4	pF

DC Specifications

Differential CML [6]

Parameter	Description	Test Conditions	Min	Max	Unit
Transmitter CML compatible Outputs					
V _{OHC}	Output HIGH Voltage (V _{CC} Referenced)	100 Ω differential load	V _{CC} - 0.5	V _{CC} - 0.15	V
V _{OLC}	Output LOW Voltage (V _{CC} Referenced)	100 Ω differential load	V _{CC} - 1.2	V _{CC} - 0.7	V
V _{DIFFOC}	Output Differential Swing	100 Ω differential load	560	1600	mV
V _{SGLCO}	Output Single-ended Voltage	100 Ω differential load	280	800	mV
Receiver CML compatible Inputs					
V _{INSGLC}	Input Single-ended Swing		25	1000	mV
V _{DIFFC}	Input Differential Voltage		50	2000	mV
V _{ICHH}	Highest Input HIGH Voltage		-	V _{CC}	V
V _{ICLL}	Lowest Input LOW Voltage		1.2	-	V

Figure 3. Differential Waveform Definition

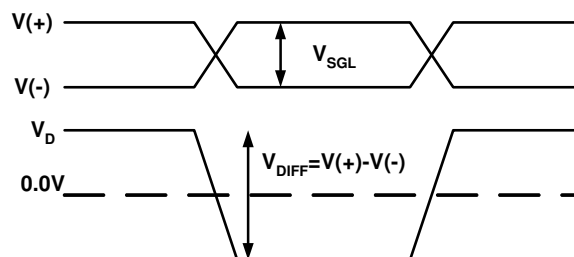

Note

6. See Figure 3 for differential waveform definition.

DC Specifications

HSTL

Parameter	Description	Test Conditions	Min	Max	Unit
HSTL Outputs					
V_{OHH}	Output HIGH Voltage	$V_{CC} = \text{min}, I_{OH} = -4.0 \text{ mA}$	$V_{DDQ} - 0.4$		V
V_{OLH}	Output LOW Voltage	$V_{CC} = \text{min}, I_{OL} = 4.0 \text{ mA}$		0.4	V
I_{OSH}	Output Short Circuit Current	$V_{OUT} = 0V$		100	mA
HSTL Inputs					
V_{IHH}	Input HIGH Voltage		$V_{REF} + 0.13$	$V_{DDQ} + 0.3$	V
V_{ILH}	Input LOW Voltage		-0.3	$V_{REF} - 0.1$	V
I_{IHH}	Input HIGH Current	$V_{DDQ} = \text{max}, V_{IN} = V_{DDQ}$		50	μA
I_{ILH}	Input LOW Current	$V_{DDQ} = \text{max}, V_{IN} = 0V$		-40	μA
Capacitance					
C_{INH}	Input Capacitance	$V_{DDQ} = \text{max}, \text{at } f = 1 \text{ MHz}$		5	pF

AC Test Loads and Waveforms

Figure 4. AC Waveforms

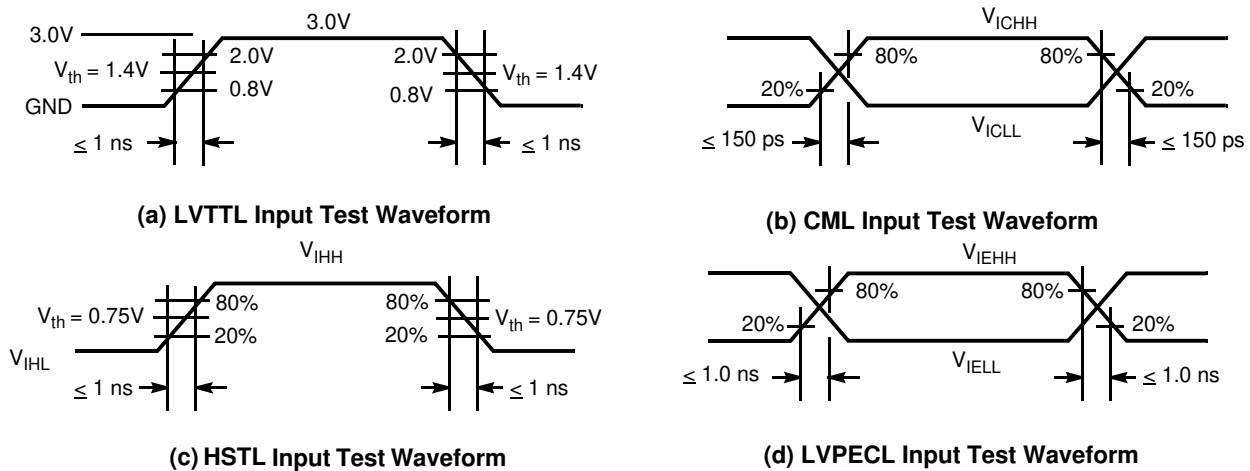
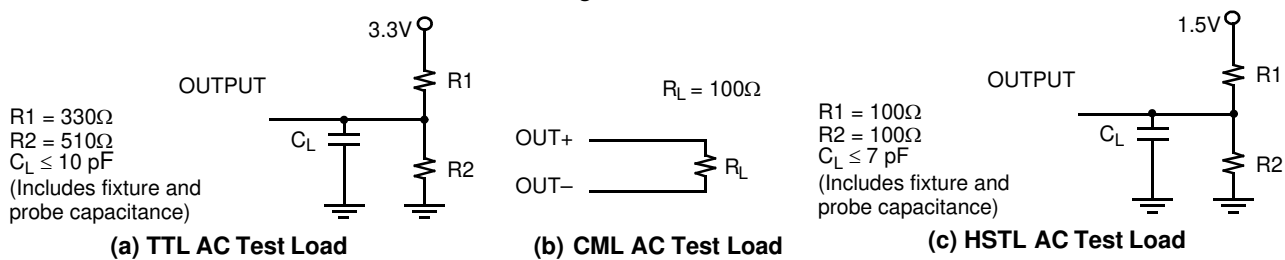

Figure 5. AC Test Loads



AC Specifications

Parallel Interface

Parameter	Description	Min	Max	Unit
t_{TS}	TXCLKI Frequency (must be frequency coherent to REFCLK)	154.5	156.5	MHz
t_{TXCLKI}	TXCLKI Period	6.38	6.47	ns
$t_{TXCLKID}$	TXCLKI Duty Cycle	40	60	%
$t_{TXCLKIR}$	TXCLKi Rise Time	0.3	1.5	ns
$t_{TXCLKIF}$	TXCLKi Fall Time	0.3	1.5	ns
t_{TXDS}	Write Data Setup to \uparrow of TXCLKI	1.5	–	ns
t_{TXDH}	Write Data Hold from \uparrow of TXCLKI	0.5	–	ns
t_{TOS}	TXCLKO Frequency	154.5	156.5	MHz
t_{TXCLKO}	TXCLKO Period	6.38	6.47	ns
$t_{TXCLKOD}$	TXCLKO Duty Cycle	43	57	%
$t_{TXCLKOR}$	TXCLKO Rise Time	0.3	1.5	ns
$t_{TXCLKOF}$	TXCLKO Fall Time	0.3	1.5	ns
t_{RS}	RXCLK Frequency	154.5	156.5	MHz
t_{RXCLK}	RXCLK Period	6.38	6.47	ns
t_{RXCLKD}	RXCLK Duty Cycle	43	57	%
t_{RXCLKR}	RXCLK Rise Time ^[7]	0.3	1.5	ns
t_{RXCLKF}	RXCLK Fall Time ^[7]	0.3	1.5	ns
t_{RXDS}	Recovered Data Setup with reference to \uparrow of RXCLK	2.2	–	ns
t_{RXDH}	Recovered Data Hold with reference to \uparrow of RXCLK	2.2	–	ns
t_{RXPd}	Valid Propagation Delay	–1.0	1.0	ns

AC Specifications

REFCLK^[8]

Parameter	Description	Min	Max	Unit
t_{REF}	REFCLK Input Frequency	154.5	156.5	MHz
t_{REFP}	REFCLK Period	6.38	6.47	ns
t_{REFD}	REFCLK Duty Cycle	35	65	%
t_{REFT}	REFCLK Frequency Tolerance — (relative to received serial data) ^[9]	–100	+100	ppm
t_{REFR}	REFCLK Rise Time	0.3	1.5	ns
t_{REFF}	REFCLK Fall Time	0.3	1.5	ns

Notes

7. RXCLK rise time and fall times are measured at the 20 to 80 percentile region of the rising and falling edge of the clock signal.
8. The 155.52 MHz Reference Clock Phase Noise Limits for the CYS25G0101DX are shown in [Figure 8](#).
9. ± 20 ppm is required to meet the SONET output frequency specification.

AC Specifications

CML Serial Outputs

Parameter	Description	Min	Typ	Max	Unit
t_{RISE}	CML Output Rise Time (20–80%, 100 Ω balanced load)	60	–	170	ps
t_{FALL}	CML Output Fall Time (80–20%, 100 Ω balanced load)	60	–	170	ps

Jitter Specifications

Parameter	Description	Min	Typ ^[10]	Max ^[10]	Unit
$t_{TJ-TXPLL}$	Total Output Jitter for TX PLL (p-p) ^[11]	–	0.03	0.04	UI
	Total Output Jitter for TX PLL (rms) ^[11, 12]	–	0.007	0.008	UI
$t_{TJ-RXPLL}$	Total Output Jitter for RX CDR PLL (p-p) ^[11]	–	0.035	0.05	UI
	Total Output Jitter for RX CDR PLL (rms) ^[11, 12]	–	0.008	0.01	UI

Notes

10. Typical values are measured at room temperature and the Max values are measured at 0 °C.
 11. The RMS and P-to-P jitter values are measured using a 12 KHz to 20 MHz SONET filter.
 12. This device passes the Bellcore specification from -10 °C to 85 °C.

Jitter Waveforms

Figure 6. Jitter Transfer Waveform of CYS25G0101DX [13]

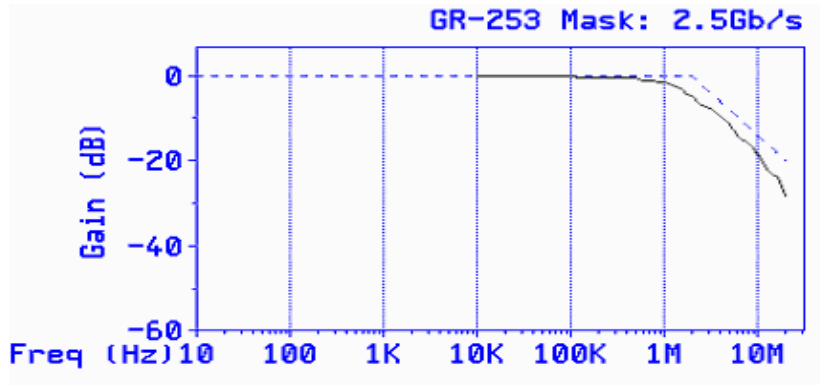

Figure 7. Jitter Tolerance Waveform of CYS25G0101DX [13]

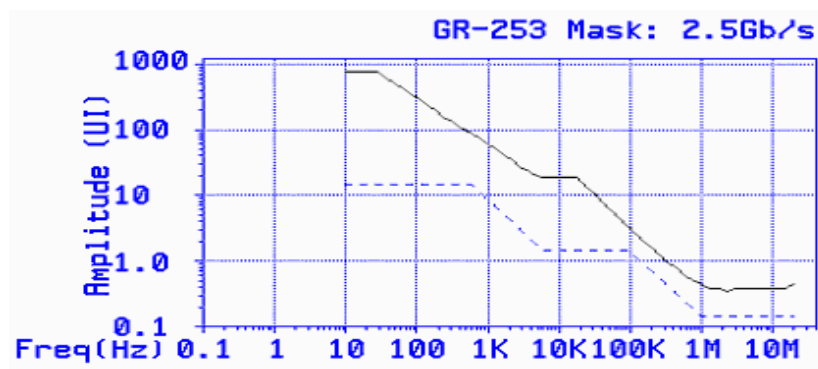
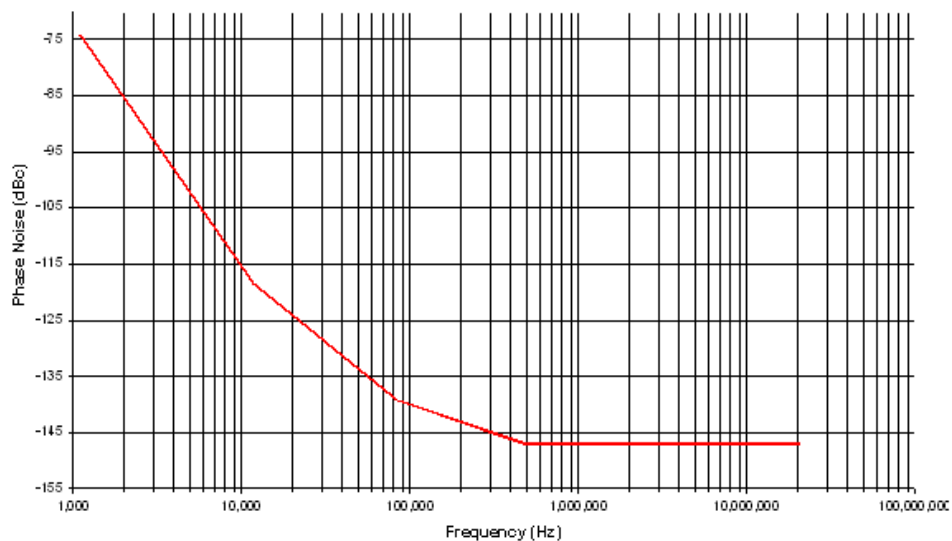

Figure 8. CYS25G0101DX Reference Clock Phase Noise Limits



Notes

13. The bench jitter measurements are performed using an Agilent Omni bert SONET jitter tester.

Switching Waveforms

Figure 9. Transmit Interface Timing

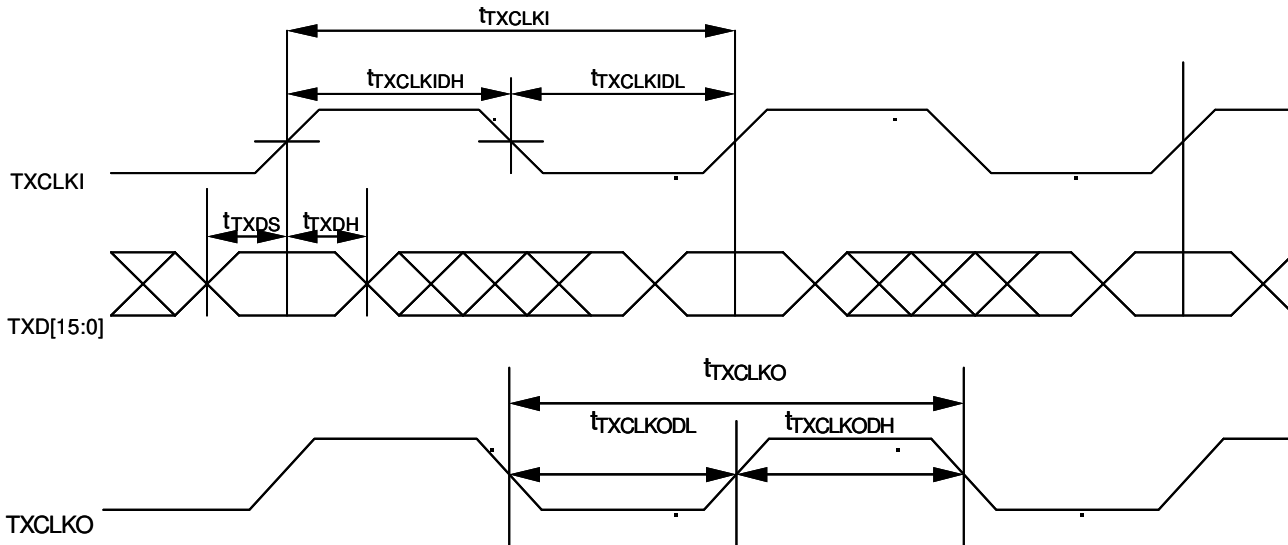
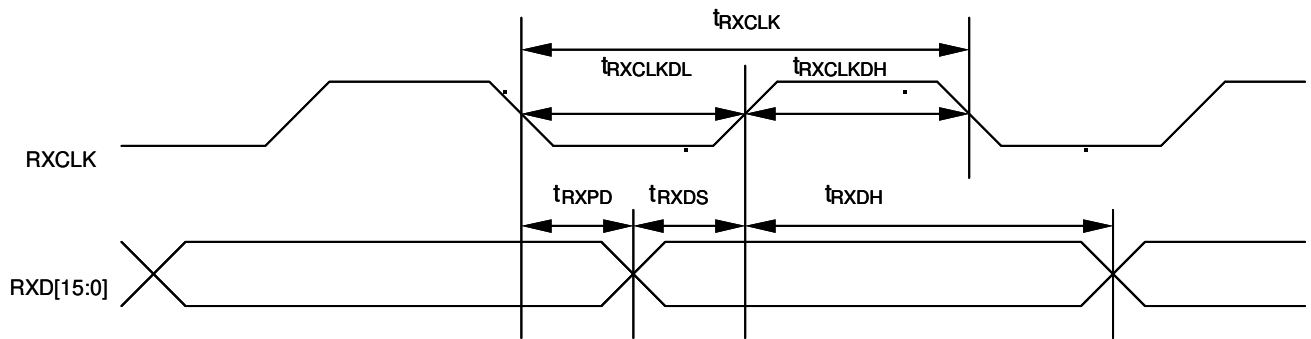

Figure 10. Receive Interface Timing



Typical IO Terminations

Figure 11. Serial Input Termination

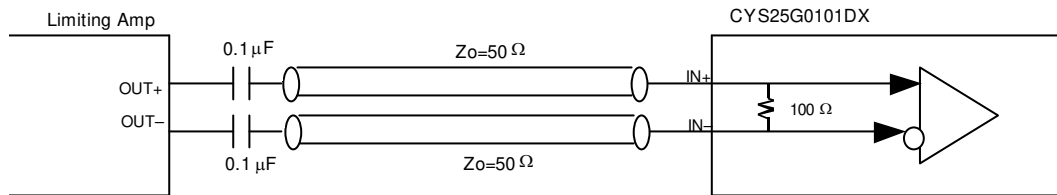

Figure 12. Serial Output termination [14]

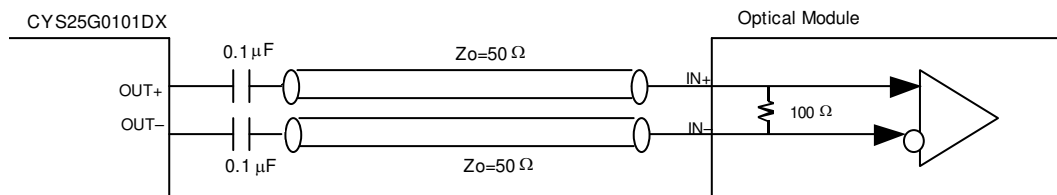

Figure 13. TXCLKO/ RXCLK Termination

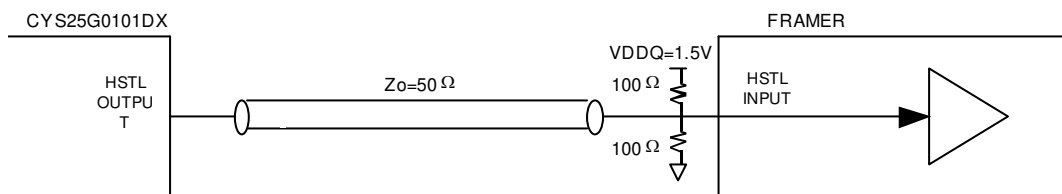

Figure 14. RXD[15:0] Termination

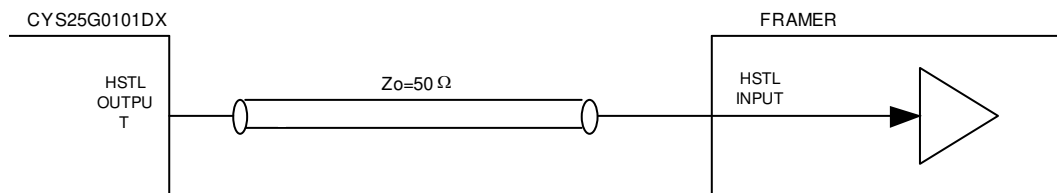
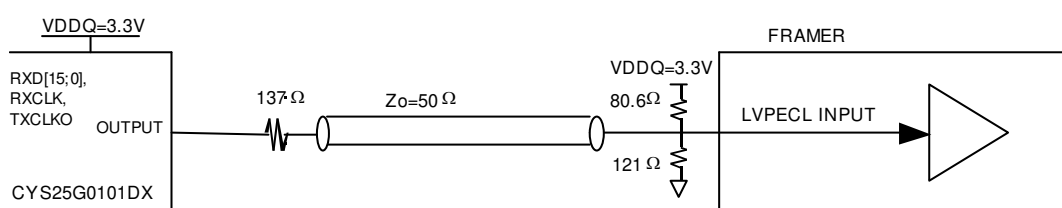

Figure 15. LVPECL Compliant Output Termination



Note

14. Serial output of CYS25G0101DX is source matched to 50 Ω transmission lines (100 Ω differential transmission lines).

Typical IO Terminations (continued)

Figure 16. AC Coupled Clock Oscillator Termination

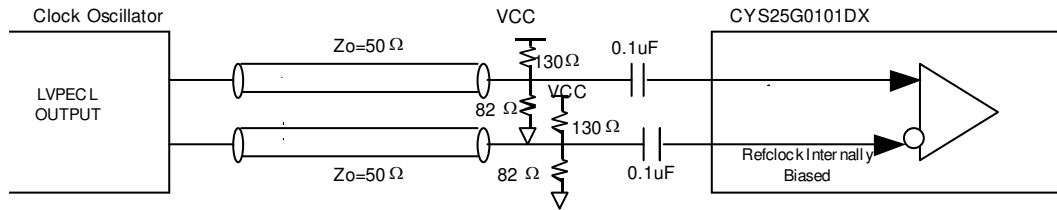
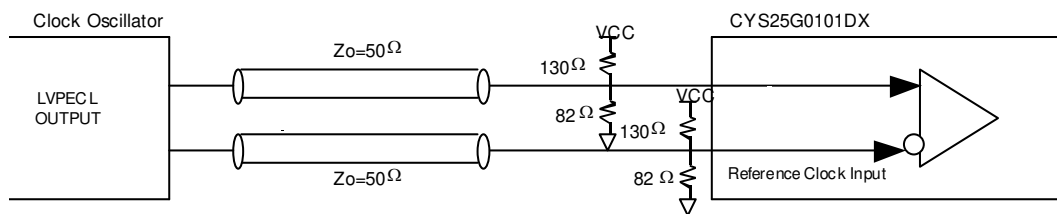

Figure 17. Clock Oscillator Termination



Ordering Information

Speed	Ordering Code	Package Name	Package Type	Operating Range
Standard	CYS25G0101DX-AEXC	AE120	120-pin TQFP (Pb-free)	Commercial

Ordering Code Definitions

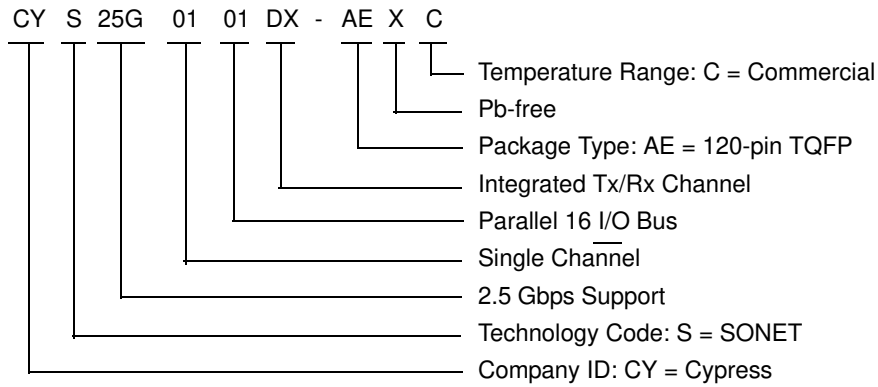

Package Diagram

Figure 18. 120-pin TQFP (14 x 14 x 1.0 mm) AE120A (6.5 x 6.5 E-Pad) Package Outline, 001-48723

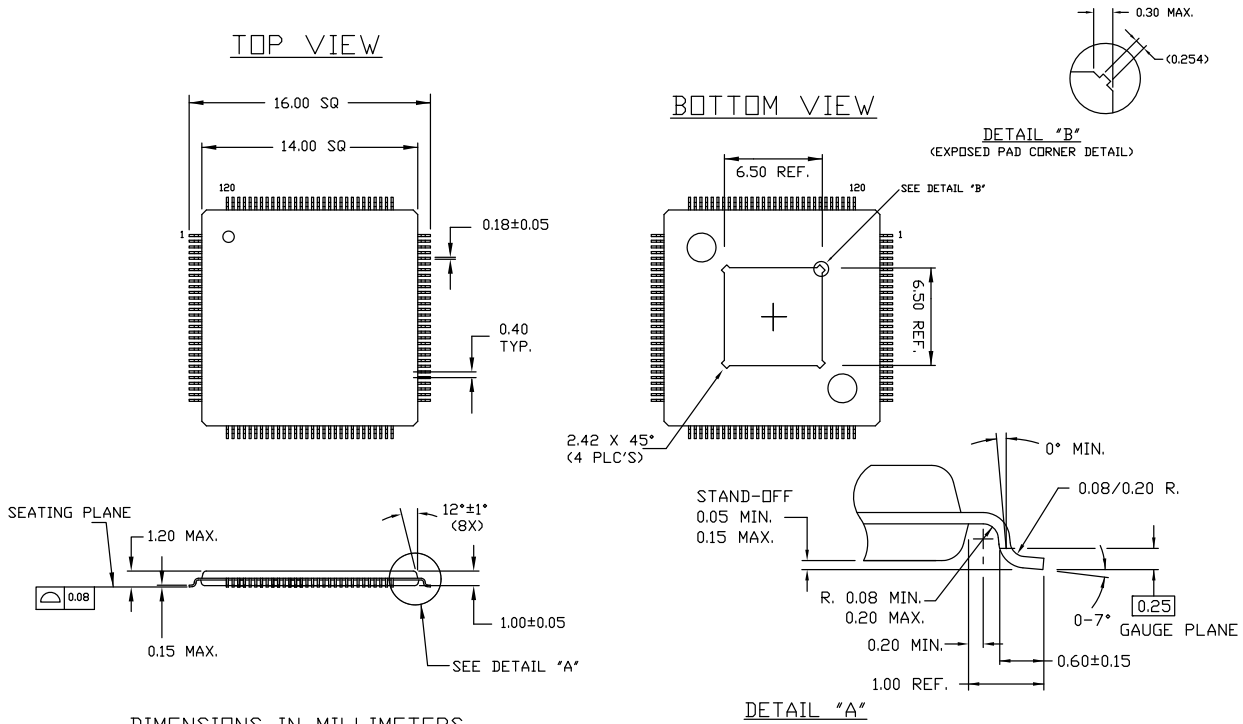

DIMENSIONS IN MILLIMETERS
 Refer to Jedec Drawing MS-026
 Package Weight - Refer to PMDD spec.

001-48723 *B

Document History Page

Document Title: CYS25G0101DX SONET OC-48 Transceiver				
Document Number: 38-02009				
Rev.	ECN No.	Submission Date	Orig. of Change	Description of Change
**	105847	03/22/01	SZV	Change from Specification number: 38-00894 to 38-02009.
*A	108024	06/20/01	AMV	Changed Marketing part number.
*B	111834	12/18/01	CGX	Updated power specification in features and DC specifications section. Changed pinout for compatibility with CYS25G0102DX in pin diagram and descriptions. Verbiage added or changed for clarity in pin descriptions section. Changed input sensitivity in Receive Data Path section, page 6. RXCLK rise time corrected to 0.3 nSec min CML and LVPECL input waveforms updated in test load and waveform section. Diagrams replaced for clarity Figures 1-10. Added two Reflock diagrams Figures 9 and 10.
*C	112712	02/06/02	TME	Updated temperature range, static discharge voltage, and max total RMS jitter.
*D	113791	04/24/02	CGX	Updated the single ended swing and differential swing voltage for Receiver CML compatible inputs. Created a separate table showing peak to peak and RMS jitter for both TX PLL and RX PLL.
*E	115940	05/22/02	TME	Added Industrial temperature specification to pages 8, 11, and 15.
*F	117906	09/06/02	CGX	Added differential waveform definition. Added BGA pinout and package information. Changed LVTTTL V _{IHT} min from 2.0 to 2.1 volts.
*G	119267	10/17/02	CGX	Added phase noise limits data. Removed BGA pinout and package information. Removed references to CYS25G0102DX.
*H	121019	11/06/02	CGX	Removed "Preliminary" from datasheet
*I	122319	12/30/02	RBI	Added power up requirements to Maximum Ratings information
*J	124438	02/13/03	WAI	Revised power up requirements
*K	1309983	07/27/07	IUS / SFV	Added Pb-free logo Added Pb-free parts to the Ordering Information: CYS25G0101DX-ATXC, CYS25G0101DX-ATXI
*L	2647349	01/26/09	AAE / PYRS	Revised the ordering information to only reflect the new marketing part numbers defined for the new 120AE (e-pad) package. Updated the package diagram per spec 001-48723.
*M	2897889	03/23/10	CGX	Removed inactive parts from Ordering Information. Updated Package Diagram .
*N	3051122	10/07/10	NVNS	Added Ordering Code Definitions .
*O	4173317	10/24/2013	NVNS	Updated Package Diagram : spec 001-48723 – Changed revision from *A to *B. Updated in new template. Completing Sunset Review.

Sales, Solutions, and Legal Information

Worldwide Sales and Design Support

Cypress maintains a worldwide network of offices, solution centers, manufacturer's representatives, and distributors. To find the office closest to you, visit us at [Cypress Locations](#).

Products

Automotive	cypress.com/go/automotive
Clocks & Buffers	cypress.com/go/clocks
Interface	cypress.com/go/interface
Lighting & Power Control	cypress.com/go/powerpsoc cypress.com/go/plc
Memory	cypress.com/go/memory
PSoC	cypress.com/go/psoc
Touch Sensing	cypress.com/go/touch
USB Controllers	cypress.com/go/USB
Wireless/RF	cypress.com/go/wireless

PSoC[®] Solutions

[psoc.cypress.com/solutions](#)
[PSoC 1](#) | [PSoC 3](#) | [PSoC 4](#) | [PSoC 5LP](#)

Cypress Developer Community

[Community](#) | [Forums](#) | [Blogs](#) | [Video](#) | [Training](#)

Technical Support

[cypress.com/go/support](#)

© Cypress Semiconductor Corporation, 2001-2013. The information contained herein is subject to change without notice. Cypress Semiconductor Corporation assumes no responsibility for the use of any circuitry other than circuitry embodied in a Cypress product. Nor does it convey or imply any license under patent or other rights. Cypress products are not warranted nor intended to be used for medical, life support, life saving, critical control or safety applications, unless pursuant to an express written agreement with Cypress. Furthermore, Cypress does not authorize its products for use as critical components in life-support systems where a malfunction or failure may reasonably be expected to result in significant injury to the user. The inclusion of Cypress products in life-support systems application implies that the manufacturer assumes all risk of such use and in doing so indemnifies Cypress against all charges.

Any Source Code (software and/or firmware) is owned by Cypress Semiconductor Corporation (Cypress) and is protected by and subject to worldwide patent protection (United States and foreign), United States copyright laws and international treaty provisions. Cypress hereby grants to licensee a personal, non-exclusive, non-transferable license to copy, use, modify, create derivative works of, and compile the Cypress Source Code and derivative works for the sole purpose of creating custom software and or firmware in support of licensee product to be used only in conjunction with a Cypress integrated circuit as specified in the applicable agreement. Any reproduction, modification, translation, compilation, or representation of this Source Code except as specified above is prohibited without the express written permission of Cypress.

Disclaimer: CYPRESS MAKES NO WARRANTY OF ANY KIND, EXPRESS OR IMPLIED, WITH REGARD TO THIS MATERIAL, INCLUDING, BUT NOT LIMITED TO, THE IMPLIED WARRANTIES OF MERCHANTABILITY AND FITNESS FOR A PARTICULAR PURPOSE. Cypress reserves the right to make changes without further notice to the materials described herein. Cypress does not assume any liability arising out of the application or use of any product or circuit described herein. Cypress does not authorize its products for use as critical components in life-support systems where a malfunction or failure may reasonably be expected to result in significant injury to the user. The inclusion of Cypress' product in a life-support systems application implies that the manufacturer assumes all risk of such use and in doing so indemnifies Cypress against all charges.

Use may be limited by and subject to the applicable Cypress software license agreement.