



Chipsmall Limited consists of a professional team with an average of over 10 year of expertise in the distribution of electronic components. Based in Hongkong, we have already established firm and mutual-benefit business relationships with customers from,Europe,America and south Asia,supplying obsolete and hard-to-find components to meet their specific needs.

With the principle of “Quality Parts,Customers Priority,Honest Operation,and Considerate Service”,our business mainly focus on the distribution of electronic components. Line cards we deal with include Microchip,ALPS,ROHM,Xilinx,Pulse,ON,Everlight and Freescale. Main products comprise IC,Modules,Potentiometer,IC Socket,Relay,Connector.Our parts cover such applications as commercial,industrial, and automotives areas.

We are looking forward to setting up business relationship with you and hope to provide you with the best service and solution. Let us make a better world for our industry!



Contact us

Tel: +86-755-8981 8866 Fax: +86-755-8427 6832

Email & Skype: info@chipsmall.com Web: www.chipsmall.com

Address: A1208, Overseas Decoration Building, #122 Zhenhua RD., Futian, Shenzhen, China



THIS DRAWING AND THE INFORMATION SET FORTH HEREON ARE THE PROPERTY OF TYCO ELECTRONICS AND ARE TO BE HELD IN TRUST AND CONFIDENCE. PUBLICATION, DUPLICATION, DISCLOSURE OR USE FOR ANY PURPOSE NOT EXPRESSLY AUTHORIZED IN WRITING BY TYCO ELECTRONICS IS PROHIBITED.

REVISION			
REV	DESCRIPTION	DATE	APPROVED
A	ADDED NOTE d. DCO# 01483	5-14-80	Hagman
B	PER ECO-12-006794	Apr/9/2012	M.HIGGY

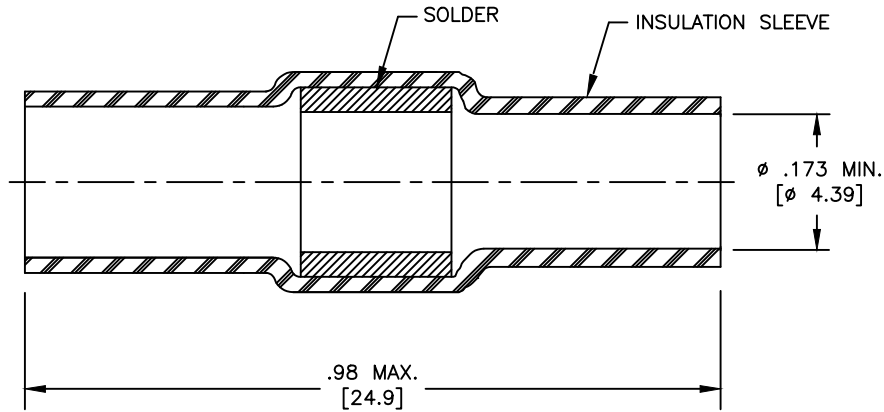

NOTES:

- THIS PART IS DESIGNED FOR USE IN RAYCHEM/TYCO SHIELD TERMINATION KITS D-659-0021, D-659-0022 (REQUIRED PARTS ARE FIVE FOR 1 INCH AND TEN FOR 2 INCH SHIELD TERMINATION)
- MATERIALS:
 INSULATION SLEEVE: HEAT SHRINKABLE, RADIATION CROSS-LINKED MODIFIED POLYVINYLIDENE FLUORIDE, TRANSPARENT BLUE.
 SOLDER: PREFORMED WITH FLUX Sn63 SRAP PER ANSI J-STD-006
- PARTS MAY BE INSTALLED WITH HOT AIR OR INFRARED HEATERS.
- ACCEPTANCE SAMPLING SHALL BE IN ACCORDANCE WITH INSPECTION LEVEL 1 FOR ANSI/ASQ Z1.4 THE ACCEPTABLE QUALITY LEVEL (AQL) SHALL BE 4.0
- THIS PART ALSO USED AS CTA-0022 AND CTA-0023 SHIELD TERMINATION.

If this document is printed it becomes uncontrolled. Check for the latest revision

Raychem MTC
CUSTOMER DRAWING

© 2012 Tyco Electronics. All rights reserved

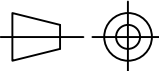
THIS DRAWING IS A CONTROLLED DOCUMENT.		DRAWN ZS.ORBAN	DATE Mar/29/2012	 TE Connectivity	
DIMENSIONING AND TOLERANCING PER ASME Y14.5M (ISO STANDARDS)		APPROVED M.HIGGY	DATE Mar/29/2012		
UNLESS OTHERWISE SPECIFIED DIMENSIONS ARE INCHES. METRIC DIMENSIONS ARE IN BRACKETS.		MATERIAL		TITLE SOLDER SLEEVE SHIELD TERMINATOR	
DECIMAL TOLERANCES .XXX ± [mm] .XX ± [mm] .X ± [mm]		FINISH		SIZE A	
ANGLE TOLERANCE .X ± 1'		THIRD ANGLE PROJECTION 		CAGE CODE: 06090	DWG. NO. D-659-0026
CAD FILE D-659-0026				REV: B	SCALE: NONE SHEET 1 OF 1