



Chipsmall Limited consists of a professional team with an average of over 10 year of expertise in the distribution of electronic components. Based in Hongkong, we have already established firm and mutual-benefit business relationships with customers from,Europe,America and south Asia,supplying obsolete and hard-to-find components to meet their specific needs.

With the principle of "Quality Parts,Customers Priority,Honest Operation,and Considerate Service",our business mainly focus on the distribution of electronic components. Line cards we deal with include Microchip,ALPS,ROHM,Xilinx,Pulse,ON,Everlight and Freescale. Main products comprise IC,Modules,Potentiometer,IC Socket,Relay,Connector.Our parts cover such applications as commercial,industrial, and automotives areas.

We are looking forward to setting up business relationship with you and hope to provide you with the best service and solution. Let us make a better world for our industry!



Contact us

Tel: +86-755-8981 8866 Fax: +86-755-8427 6832

Email & Skype: info@chipsmall.com Web: www.chipsmall.com

Address: A1208, Overseas Decoration Building, #122 Zhenhua RD., Futian, Shenzhen, China



SPECIFICATION CONTROL DRAWING

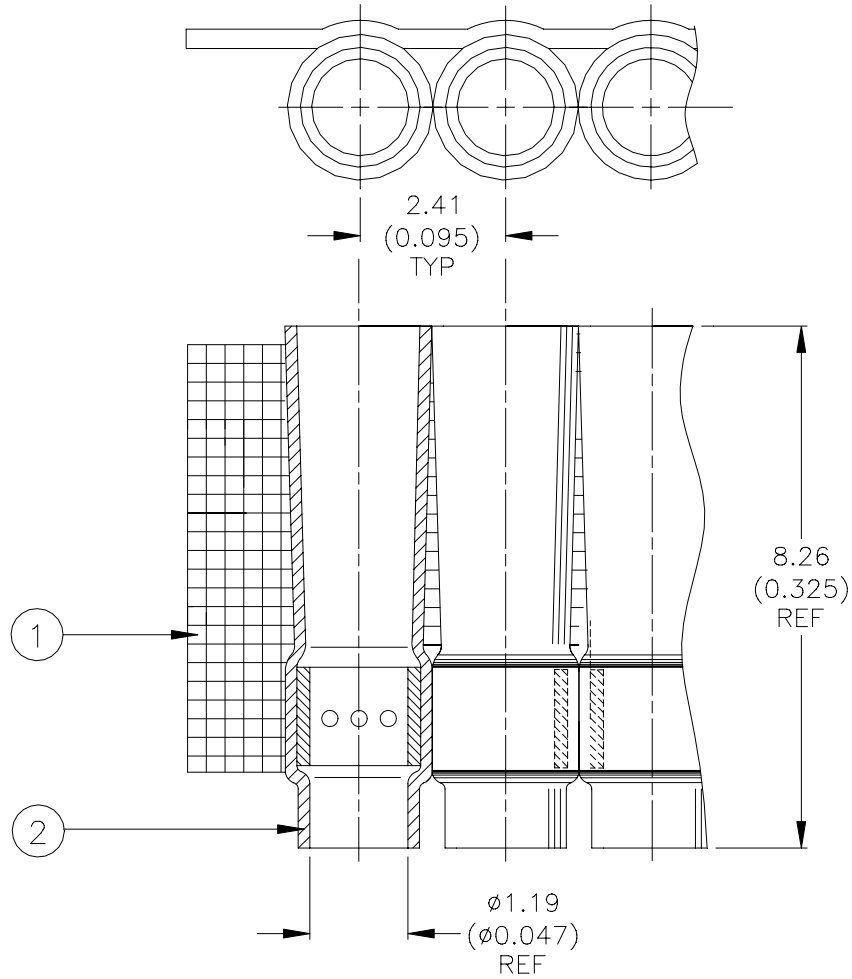

MATERIALS

1. SOLDERSLLEEVE: D-136-07, Quantity Per Assembly: 1000
2. CARRIER STRIP: Adhesive Coated High Temperature Tape

APPLICATION

1. This assembly is for used on Continental MM22 or Winchester SRE connectors.
2. Sleeves are to be installed using Raychem-approved convection or infrared heating tools.
3. The carrier strip is to be removed before heating.

 307 Constitution Drive Menlo Park, CA 94025, USA		Wire and Harnessing Products		TITLE : SOLDERPAK ASSEMBLY, Continental MM22 and Winchester SRE Connectors; 22/26 AWG High Temperature Wire			
UNLESS OTHERWISE SPECIFIED DIMENSIONS ARE IN MILLIMETERS. INCHES DIMENSIONS ARE BETWEEN BRACKETS.				DOCUMENT NO.: D-701-00			
TOLERANCES: 0.00 N/A 0.0 N/A 0 N/A	ANGLES: N/A ROUGHNESS IN MICRON	Raychem reserves the right to amend this drawing at any time. Users should evaluate the suitability of the product for their application.		DCR NUMBER: D010046		REPLACES: N/A	
DRAWN BY: M. FORONDA	DATE: 26-Jan.-01	PROD. REV. D	DOC ISSUE: 1	SCALE: None	SIZE: A	SHEET: 1 of 1	

If this document is printed it becomes uncontrolled. Check for the latest revision.