



Chipsmall Limited consists of a professional team with an average of over 10 year of expertise in the distribution of electronic components. Based in Hongkong, we have already established firm and mutual-benefit business relationships with customers from,Europe,America and south Asia,supplying obsolete and hard-to-find components to meet their specific needs.

With the principle of “Quality Parts,Customers Priority,Honest Operation,and Considerate Service”,our business mainly focus on the distribution of electronic components. Line cards we deal with include Microchip,ALPS,ROHM,Xilinx,Pulse,ON,Everlight and Freescale. Main products comprise IC,Modules,Potentiometer,IC Socket,Relay,Connector.Our parts cover such applications as commercial,industrial, and automotives areas.

We are looking forward to setting up business relationship with you and hope to provide you with the best service and solution. Let us make a better world for our industry!



## Contact us

Tel: +86-755-8981 8866 Fax: +86-755-8427 6832

Email & Skype: info@chipsmall.com Web: www.chipsmall.com

Address: A1208, Overseas Decoration Building, #122 Zhenhua RD., Futian, Shenzhen, China



## SPECIFICATION CONTROL DRAWING

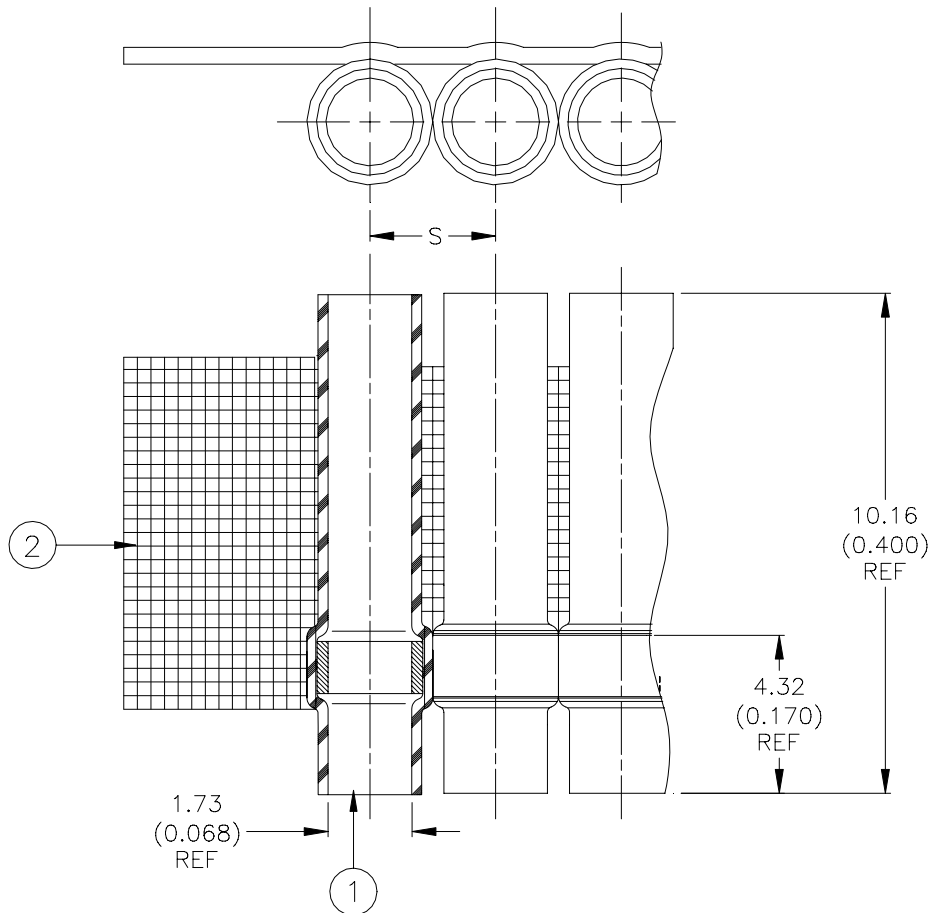

Product Name	Product Revision	S +0.51/-0.00 (S +0.020/-0.000) (center spacing dimension)	Quantity Per Assembly
D-704-0019	C	2.54 (0.100)	750
D-704-0024	C	3.81 (0.150)	500

### MATERIALS

1. SOLDER SLEEVE WIRE TERMINATOR: D-128-0014, Quantity Per Assembly: see table.
2. CARRIER STRIP: Adhesive Coated High Temperature Tape

### APPLICATION

1. This assembly is designed to be used with a Raychem AS-4000 Wire Organization System on connectors with terminals on "S" (see table) center spacing. For usage parameters, see Raychem Devices Specification Control Drawing D-128-0014.
2. Wire terminators are to be inspected to Raychem Devices Specification Control Drawing D-128-0014.

<b>tyco / Electronics / Raychem</b> 307 Constitution Drive Menlo Park, CA 94025, USA		<b>Wire and Harnessing Products</b>		TITLE: <b>2.54 (0.100), 3.81 (0.150) Centers SOLDER PAK ASSEMBLY FOR AS-4000 SLEEVE: D-128-0014</b>			
Unless otherwise specified dimensions are in millimeters. Inches dimensions are in between brackets.				DOCUMENT NO.: <b>D-704-0019/D-704-0024</b>			
TOLERANCES: 0.00 N/A 0.0 N/A 0 N/A	ANGLES: N/A  ROUGHNESS IN MICRON	Tyco Electronics reserves the right to amend this drawing at any time. Users should evaluate the suitability of the product for their application.		DCR NUMBER: D010012		REPLACES: N/A	
DRAWN BY: M. FORONDA	DATE: 08-Feb.-01	PROD. REV. SEE TABLE	DOC ISSUE: 1	SCALE: None	SIZE: A	SHEET: 1 of 1	

If this document is printed it becomes uncontrolled. Check for the latest revision.