



Chipsmall Limited consists of a professional team with an average of over 10 year of expertise in the distribution of electronic components. Based in Hongkong, we have already established firm and mutual-benefit business relationships with customers from,Europe,America and south Asia,supplying obsolete and hard-to-find components to meet their specific needs.

With the principle of “Quality Parts,Customers Priority,Honest Operation,and Considerate Service”,our business mainly focus on the distribution of electronic components. Line cards we deal with include Microchip,ALPS,ROHM,Xilinx,Pulse,ON,Everlight and Freescale. Main products comprise IC,Modules,Potentiometer,IC Socket,Relay,Connector.Our parts cover such applications as commercial,industrial, and automotives areas.

We are looking forward to setting up business relationship with you and hope to provide you with the best service and solution. Let us make a better world for our industry!



## Contact us

Tel: +86-755-8981 8866 Fax: +86-755-8427 6832

Email & Skype: info@chipsmall.com Web: www.chipsmall.com

Address: A1208, Overseas Decoration Building, #122 Zhenhua RD., Futian, Shenzhen, China



# D10040230PH1

GaAs/GaN Power Doubler Hybrid  
45MHz to 1000MHz

The D10040230PH1 is a Hybrid Power Doubler amplifier module. The part employs GaAs pHEMT die and GaN pHEMT die, has high output capability, and is operated from 45MHz to 1000MHz. It provides excellent linearity and superior return loss performance with low noise and optimal reliability.

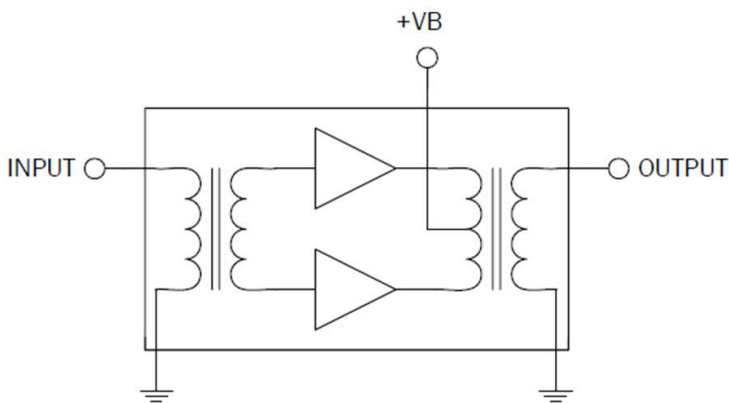

## Ordering Information

D10040230PH1      Box with 50 pieces

## Absolute Maximum Ratings

Parameter	Rating	Unit
RF Input Voltage (single tone)	60	dBmV
DC Supply Over-Voltage (5 minutes)	30	V
Storage Temperature	-40 to +100	°C
Operating Mounting Base Temperature	-30 to +100	°C



Package: SOT-115J

## Features

- Excellent Linearity
- Superior Return Loss Performance
- Extremely Low Distortion
- Optimal Reliability
- Low Noise
- Unconditionally Stable Under All Terminations
- Extremely High Output Capability
- 22.5dB Min. Gain at 1GHz
- 450mA Max. at 24VDC

## Applications

- 45MHz to 1000MHz CATV Amplifier Systems



**Caution!** ESD sensitive device.



RoHS (Restriction of Hazardous Substances): Compliant per EU Directive 2011/65/EU.

Exceeding any one or a combination of the Absolute Maximum Rating conditions may cause permanent damage to the device. Extended application of Absolute Maximum Rating conditions to the device may reduce device reliability. Specified typical performance or functional operation of the device under Absolute Maximum Rating conditions is not implied.

## Nominal Operating Parameters

Parameter	Specification			Unit	Condition
	Min	Typ	Max		
<b>General Performance</b>					<b><math>V_+ = 24V</math>; <math>T_{MB} = 30^\circ C</math>; <math>Z_S = Z_L = 75\Omega</math></b>
Power Gain	21.0	21.5	22.0	dB	$f = 45MHz$
	22.5	23.0	24.0	dB	$f = 1000MHz$
Slope <sup>[1]</sup>	1.0	1.5	2.5	dB	$f = 45MHz$ to $1000MHz$
Flatness of Frequency Response			0.8	dB	$f = 45MHz$ to $1000MHz$ (Peak to Valley)
Input Return Loss	20			dB	$f = 45MHz$ to $320MHz$
	19			dB	$f = 320MHz$ to $640MHz$
	18			dB	$f = 640MHz$ to $870MHz$
	16			dB	$f = 870MHz$ to $1000MHz$
Output Return Loss	20			dB	$f = 45MHz$ to $320MHz$
	19			dB	$f = 320MHz$ to $640MHz$
	18			dB	$f = 640MHz$ to $870MHz$
	17			dB	$f = 870MHz$ to $1000MHz$
Noise Figure		3.0	4.0	dB	$f = 50MHz$ to $1000MHz$
Total Current Consumption (DC)		430.0	450.0	mA	
<b>Distortion Data 40MHz to 550MHz</b>					<b><math>V_+ = 24V</math>; <math>T_{MB} = 30^\circ C</math>; <math>Z_S = Z_L = 75\Omega</math></b>
CTB		-77	-74	dBc	79 ch 7 dB tilted; $V_0 = 50dBmV$ at $550MHz$ , plus 75 digital channels (-6dB offset) <sup>[2]</sup>
XMOD		-71	-68	dBc	
CSO		-71	-68	dBc	
CIN	63	66		dB	

1. The slope is defined as the difference between the gain at the start frequency and the gain at the stop frequency.

2. 79 analog channels, NTSC frequency raster: 55.25MHz to 547.25MHz, +43dBmV to +50dBmV tilted output level, plus 75 digital channels, -6dB offset relative to the equivalent analog carrier.

Composite Second Order (CSO) - The CSO parameter (both sum and difference products) is defined by the NCTA.

Composite Triple Beat (CTB) - The CTB parameter is defined by the NCTA.

Cross Modulation (XMOD) - Cross modulation (XMOD) is measured at baseband (selective voltmeter method), referenced to 100% modulation of the carrier being tested.

Carrier to Intermodulation Noise (CIN) - The CIN parameter is defined by ANSI/SCTE 17 (Test Procedure for carrier to noise).

Package Drawing (Dimensions in millimeters)

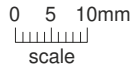
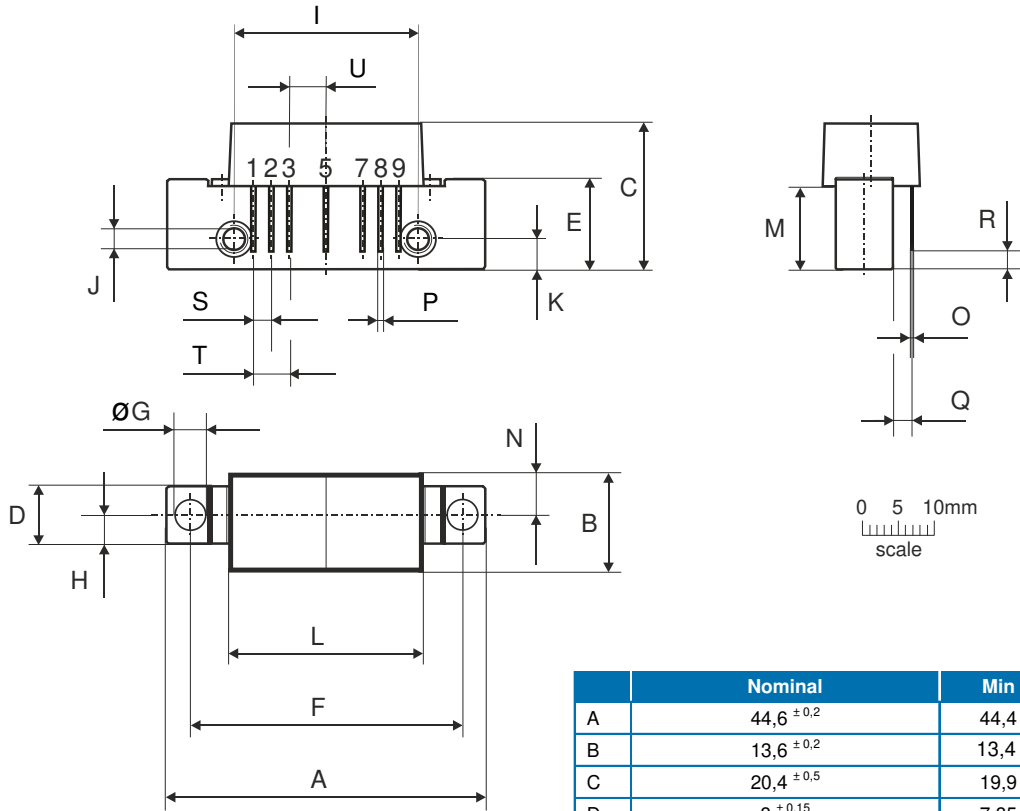

Notes:

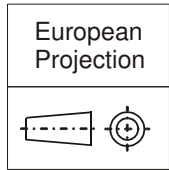

Pinning:

Pin	Name
1	Input
2-3	GND
4	
5	+VB
6	
7-8	GND
9	Output

	Nominal	Min	Max
A	44,6 ±0,2	44,4	44,8
B	13,6 ±0,2	13,4	13,8
C	20,4 ±0,5	19,9	20,9
D	8 ±0,15	7,85	8,15
E	12,6 ±0,15	12,45	12,75
F	38,1 ±0,2	37,9	38,3
G	4 <sup>+0,2/-0,05</sup>	3,95	4,2
H	4 ±0,2	3,8	4,2
I	25,4 ±0,2	25,2	25,6
J	UNC 6-32	-	-
K	4,2 ±0,2	4,0	4,4
L	27,2 ±0,2	27,0	27,4
M	11,6 ±0,5	11,1	12,1
N	5,8 ±0,4	5,4	6,2
O	0,25 ±0,02	0,23	0,27
P	0,45 ±0,03	0,42	0,48
Q	2,54 ±0,3	2,24	2,84
R	2,54 ±0,5	2,04	3,04
S	2,54 ±0,25	2,29	2,79
T	5,08 ±0,25	4,83	5,33
U	5,08 ±0,25	4,83	5,33