



Chipsmall Limited consists of a professional team with an average of over 10 year of expertise in the distribution of electronic components. Based in Hongkong, we have already established firm and mutual-benefit business relationships with customers from,Europe,America and south Asia,supplying obsolete and hard-to-find components to meet their specific needs.

With the principle of “Quality Parts,Customers Priority,Honest Operation,and Considerate Service”,our business mainly focus on the distribution of electronic components. Line cards we deal with include Microchip,ALPS,ROHM,Xilinx,Pulse,ON,Everlight and Freescale. Main products comprise IC,Modules,Potentiometer,IC Socket,Relay,Connector.Our parts cover such applications as commercial,industrial, and automotives areas.

We are looking forward to setting up business relationship with you and hope to provide you with the best service and solution. Let us make a better world for our industry!



## Contact us

Tel: +86-755-8981 8866 Fax: +86-755-8427 6832

Email & Skype: info@chipsmall.com Web: www.chipsmall.com

Address: A1208, Overseas Decoration Building, #122 Zhenhua RD., Futian, Shenzhen, China



# ZSTAR3 Accelerometer Family Expansion

## Multiple wireless sensing triple-axis reference design

### Overview

The ZSTAR3 system accommodates multiple digital and analog accelerometer boards, connected through an RF ZigBee® 2.4 GHz communication to a single USB node connected to a PC. The accelerometer boards measure acceleration in three axes using a pin compatible digital or, optionally, an analog sensor. The sensor sensitivity is defined by the selected accelerometer. The USB node is part of the ZSTAR design, equipped with dedicated software supporting multiple nodes.

Freescale is now offering the next-generation ZSTAR3 with the MMA7660FC accelerometer that offers extended functionality. The new PC software showcases the built-in intelligence of the MMA7660FC for consumer applications with orientation, shake, tap detection, auto-wake and auto-sleep. The ZSTAR3 is a small portable board design that utilizes the following products:

- MMA7660FC or MMA7455L digital triple-axis accelerometers
- MC1321x 2.4 GHz low-power transceivers and an S08 MCU in one package
- MC68HC908JW32 USB 2.0 full-speed 8-bit MCU

### Target Applications

The ZSTAR3 design provides small portable boards with the capacity to demonstrate and evaluate various accelerometer applications that accommodate a cost-effective, low-power wireless connection. Applications include:

- Mobile phones
- Hand-held gaming devices
- Portable media players
- MP3 players
- PDAs
- Personal computer peripherals
- GPS navigation devices
- Remote controls

### MMA7660FC ZSTAR3

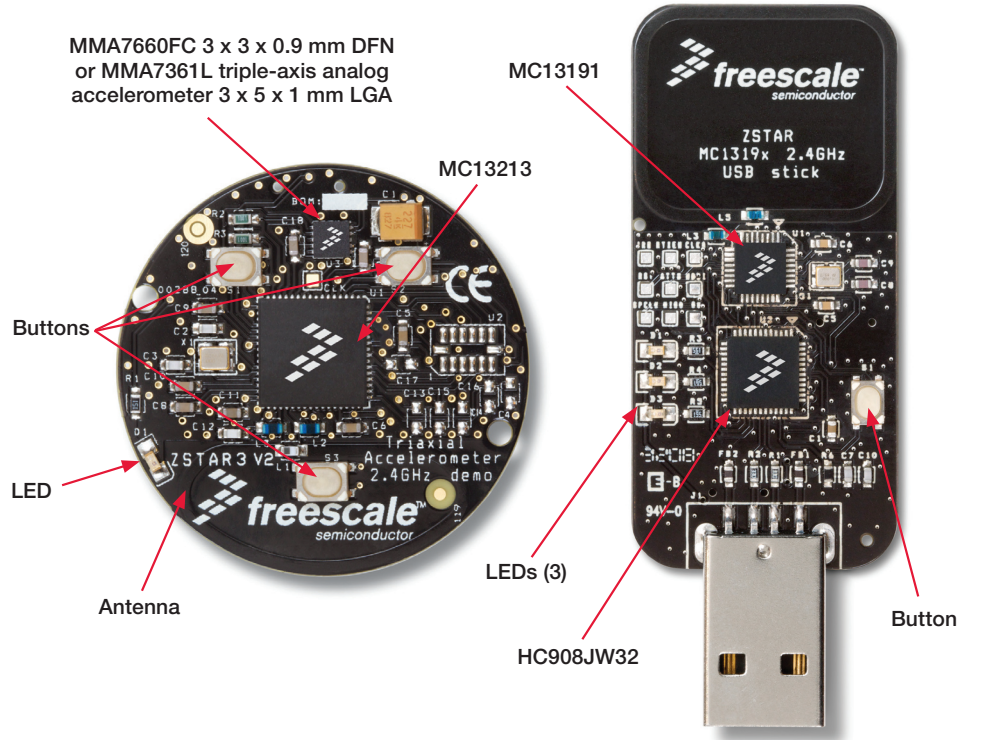

### Competitive Advantages

Feature	Description
Multi-axis acceleration sensor	<ul style="list-style-type: none"> <li>• Ultra small size</li> <li>• High sensitivity and selectable g-range of acceleration for multi-functional applications</li> <li>• Fast power-up response time</li> </ul>
MC13213 (ZigBee-compliant platform—2.4 GHz low-power transceiver plus microcontroller)	<ul style="list-style-type: none"> <li>• Cost-effective solution for fast time to market</li> <li>• ZigBee 2.4 GHz allows global deployment and mesh networks</li> <li>• System in package (SiP) means reduced PCB size of the solution and less external components</li> </ul>
MC68HC908JW32 USB 2.0 full-speed 8-bit MCU	<ul style="list-style-type: none"> <li>• Available with a variety of memory sizes and types, modules and packages</li> <li>• Easy to learn and use architecture</li> <li>• C-optimized architecture provides compact code</li> </ul>
Low-power, low-current operation	<ul style="list-style-type: none"> <li>• Battery life extension</li> </ul>

### MMA7660FC Digital Accelerometer

- $\pm 1.5g$  three-axis digital accelerometer with I<sup>2</sup>C
- Small, low-profile 3 x 3 x 0.9 mm DFN package
- MMA7660FC low current consumption specifications
  - Off mode: 0.4  $\mu A$
  - Standby mode: 2  $\mu A$
  - Active mode: 47  $\mu A$  at one sample per second
  - Configurable output data rate from 1 to 120 samples per second
- Configurable orientation detection for portrait/landscape capability
  - Six orientations: left, right, up, down, back and front
- Gesture detection, including shake and tap detection

### MMA7455L Digital Accelerometer

- Digital output (I<sup>2</sup>C/SPI) for processor system performance
- Small, low-profile 3 mm x 5 mm x 1 mm 14-pin LGA package
- XYZ: three axes of sensitivity in one device (2g, 4g, 8g)
- Single or double click (pulse) recognition
- High sensitivity
  - 64 LSB/g at 2g
  - 64 LSB/g at 8g in 10-bit mode

### MC13213 ZigBee Platform

- IEEE 802.15.4 standard compliant on-chip transceiver/modem
- 2.4 GHz
- 16 selectable channels
- Programmable output power
- Multiple power saving modes
- 2V to 3.4V operating voltage with on-chip voltage regulators

### ZSTAR3 Software Concepts

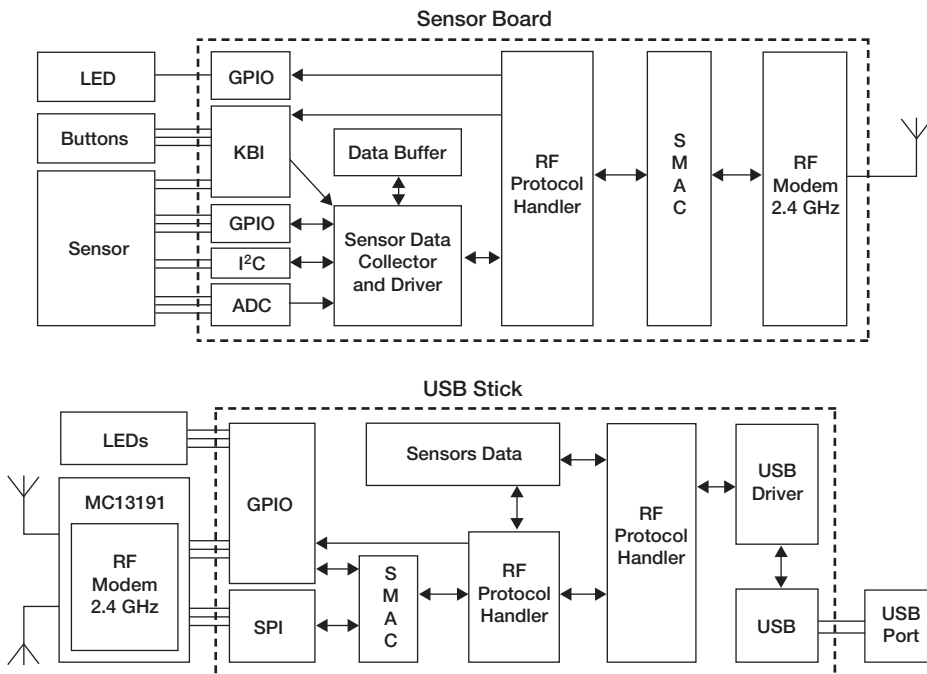

### Wireless Sensing Triple-Axis Reference Design (ZSTAR) Development Tool Family

Part Number	Description
RD3965MMA7660FC	ZSTAR3 featuring the MMA7660FC digital accelerometer
RD3172MMA7455L	ZSTAR3 featuring the MMA7455L digital accelerometer
D3172MMA7361L	Analog sensor only for the ZSTAR3
D3172MMA7455L	Digital sensor only for the ZSTAR3

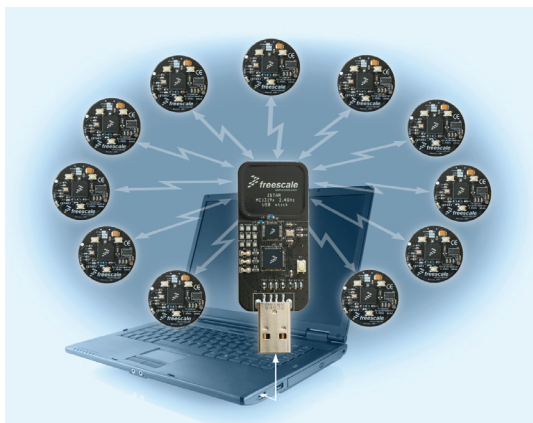

**Learn More:** For more information about Freescale sensor tools, please visit [www.freescale.com/zstar](http://www.freescale.com/zstar).