



Chipsmall Limited consists of a professional team with an average of over 10 year of expertise in the distribution of electronic components. Based in Hongkong, we have already established firm and mutual-benefit business relationships with customers from,Europe,America and south Asia,supplying obsolete and hard-to-find components to meet their specific needs.

With the principle of “Quality Parts,Customers Priority,Honest Operation,and Considerate Service”,our business mainly focus on the distribution of electronic components. Line cards we deal with include Microchip,ALPS,ROHM,Xilinx,Pulse,ON,Everlight and Freescale. Main products comprise IC,Modules,Potentiometer,IC Socket,Relay,Connector.Our parts cover such applications as commercial,industrial, and automotives areas.

We are looking forward to setting up business relationship with you and hope to provide you with the best service and solution. Let us make a better world for our industry!



Contact us

Tel: +86-755-8981 8866 Fax: +86-755-8427 6832

Email & Skype: info@chipsmall.com Web: www.chipsmall.com

Address: A1208, Overseas Decoration Building, #122 Zhenhua RD., Futian, Shenzhen, China



DA7218

DA7218 is a high-performance, low-power audio codec optimized for use in portable applications or wearable devices. It has single-ended headphone outputs with headphone detect for use in accessories, offering excellent left to right channel separation and common mode noise rejection.

DA7218 also has a stereo DAC to headphone output path and ultra-low power operating modes to support always-on audio detect applications.

DA7218 contains two analog microphone input paths, or up to four digital microphone input paths, or a combination of both. The other chip in this family, the DA7217 has differential headphone outputs without headphone detect, and has been designed for use inside headset devices.



32 ball WLCSP package, 0.5 mm pitch

Features

- ▶ High performance stereo DAC to headphone playback path with 110 dB dynamic range
- ▶ 4 mW stereo playback power consumption
- ▶ DAC digital filters with audio and voice mode options, five-band equalizer and five programmable biquad stages
- ▶ Dedicated low-latency digital sideband filter with three programmable biquad stages
- ▶ High performance microphone to ADC record path with a 105 dB dynamic range
- ▶ 2.5 mW stereo record power consumption
- ▶ ADC digital filters with audio and voice mode options
- ▶ 500 μ W always-on record mode with automatic level detection
- ▶ Hybrid analog / digital automatic level control to dynamically control the record level
- ▶ Shutdown mode offering current consumption during standby of 2.5 μ A
- ▶ Two low-noise microphone bias regulators with programmable output voltage and ultralow power mode
- ▶ Ability to differentiate between stereo and mono headsets
- ▶ Automatic detection of headset removal and confirmation of headset insertion
- ▶ Voice mode filtering up to 32 kHz
- ▶ Flexible digital mixing from all seven inputs to all six outputs with independent gain on each mixer path
- ▶ Ability to run the ADCs at a different sample rate to the DACs on a single I2S interface
- ▶ Digital tone generator with built-in support for DTMF
- ▶ System controller for simplified, pop-free startup and shutdown
- ▶ Phase-locked loop with sample rate tracking supporting MCLK frequencies from 2 MHz to 54 MHz
- ▶ Automatic tuning of on-chip reference oscillator for clock-free operation in low-power modes
- ▶ 4-wire digital audio interface with support for I²S, four-channel I²S, TDM and other audio formats
- ▶ 2-wire I²C compatible control interface with support for High Speed mode up to 3.4 MHz
- ▶ 24-bit data at up to 96 kHz sample rate
- ▶ A high efficiency two-level, true-ground charge pump for generating class-G headphone supplies

Applications

- ▶ Wired Headsets
- ▶ Wired Headphones
- ▶ Gaming Console Controller
- ▶ Audio Accessories
- ▶ Portable Media Player
- ▶ Tablet & ebooks

Block Diagram

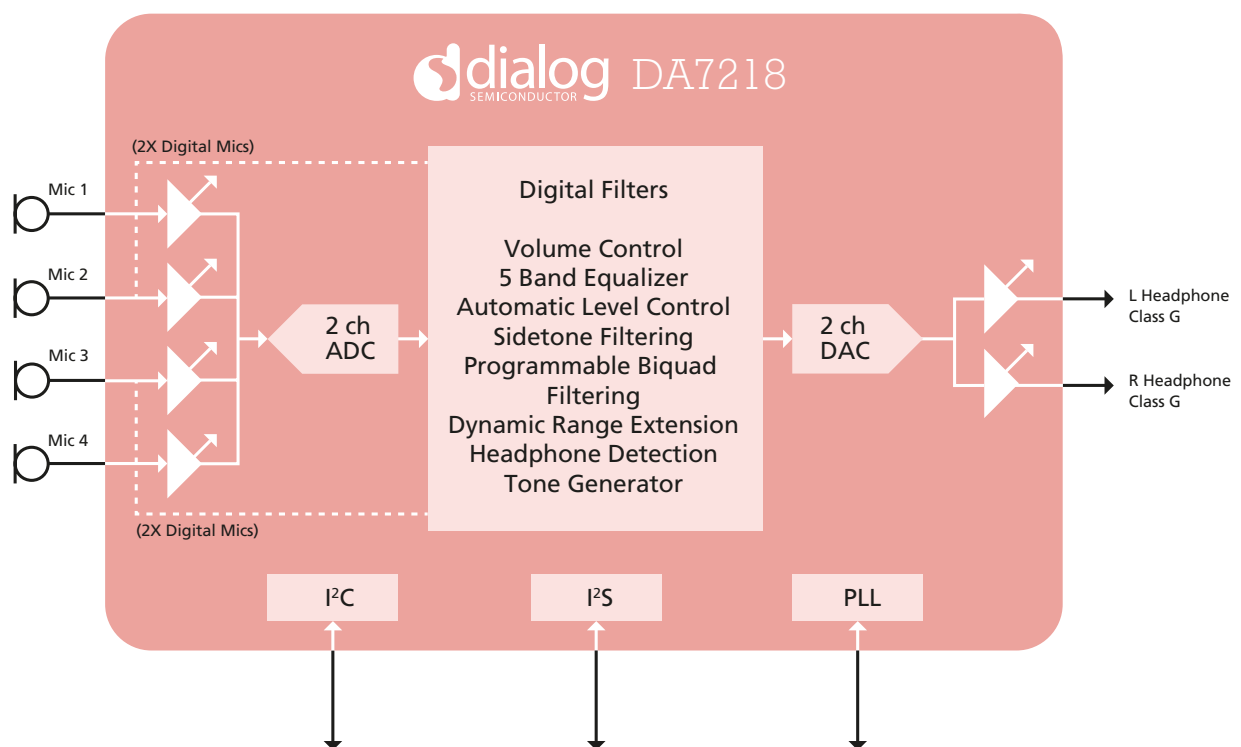

Feature highlights

- ▶ Superior hi-fidelity audio performance for immersive record and playback
- ▶ Sub 500 μ W always-on power extends battery life for audio activity detection
- ▶ Flexible programming filtering (sideband, voice) enhances voice and audio playback
- ▶ Mixed sample rate support for wideband applications
- ▶ Supports the latest generation of low power analog and digital microphones
- ▶ Small package footprint with an optimized ball-out conducive to low cost PCB manufacturing

Audio System diagram

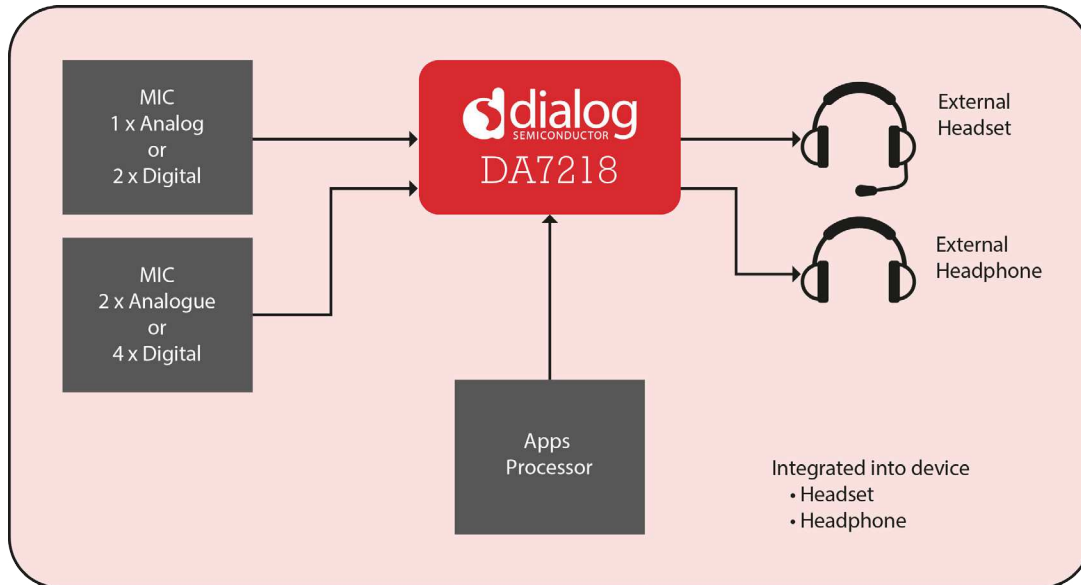

Dialog Semiconductor Worldwide Sales Offices - www.dialog-semiconductor.com

email: info@diasemi.com

United Kingdom
Phone: +44 1793 757700

The Netherlands
Phone: +31 73 640 88 22

Japan
Phone: +81 3 5425 4567

Singapore
Phone: +65 648 499 29

Korea
Phone: +82 2 3469 8200

Germany
Phone: +49 7021 805-0

North America
Phone: +1 408 845 8500

Taiwan
Phone: +886 281 786 222

Hong Kong
Phone: +852 3769 5200

China (Shenzhen)
Phone: +86 755 2981 3669
China (Shanghai)
Phone: +86 21 5424 9058

This publication is issued to provide outline information only, which unless agreed by Dialog Semiconductor may not be used, applied, or reproduced for any purpose or be regarded as a representation relating to products. All use of Dialog Semiconductor products, software and applications referred to in this document are subject to Dialog Semiconductor's [Standard Terms and Conditions of Sale](http://www.dialog-semiconductor.com), available on the company website (www.dialog-semiconductor.com) unless otherwise stated.

Dialog and the Dialog logo are trademarks of Dialog Semiconductor plc or its subsidiaries. All other product or service names are the property of their respective owners.

© Copyright 2016 Dialog Semiconductor. All rights reserved.