



Chipsmall Limited consists of a professional team with an average of over 10 year of expertise in the distribution of electronic components. Based in Hongkong, we have already established firm and mutual-benefit business relationships with customers from,Europe,America and south Asia,supplying obsolete and hard-to-find components to meet their specific needs.

With the principle of “Quality Parts,Customers Priority,Honest Operation,and Considerate Service”,our business mainly focus on the distribution of electronic components. Line cards we deal with include Microchip,ALPS,ROHM,Xilinx,Pulse,ON,Everlight and Freescale. Main products comprise IC,Modules,Potentiometer,IC Socket,Relay,Connector.Our parts cover such applications as commercial,industrial, and automotives areas.

We are looking forward to setting up business relationship with you and hope to provide you with the best service and solution. Let us make a better world for our industry!



Contact us

Tel: +86-755-8981 8866 Fax: +86-755-8427 6832

Email & Skype: info@chipsmall.com Web: www.chipsmall.com

Address: A1208, Overseas Decoration Building, #122 Zhenhua RD., Futian, Shenzhen, China



FEATURES

- Fast settling output current: 85 ns**
- Full-scale current prematched to ± 1 LSB**
- Direct interface to TTL, CMOS, ECL, HTL, PMOS**
- Nonlinearity to 0.1% maximum over temperature range**
- High output impedance and compliance: -10 V to $+18$ V**
- Complementary current outputs**
- Wide range multiplying capability: 1 MHz bandwidth**
- Low FS current drift: ± 10 ppm/ $^{\circ}$ C**
- Wide power supply range: ± 4.5 V to ± 18 V**
- Low power consumption: 33 mW at ± 5 V**
- Low cost**

GENERAL DESCRIPTION

The DAC08 series of 8-bit monolithic digital-to-analog converters provide very high speed performance coupled with low cost and outstanding applications flexibility.

Advanced circuit design achieves 85 ns settling times with very low glitch energy and at low power consumption. Monotonic multiplying performance is attained over a wide 20 to 1 reference current range. Matching to within 1 LSB between reference and full-scale currents eliminates the need for full-scale trimming in most applications.

Direct interface to all popular logic families with full noise immunity is provided by the high swing, adjustable threshold logic input.

High voltage compliance complementary current outputs are provided, increasing versatility and enabling differential operation to effectively double the peak-to-peak output swing. In many applications, the outputs can be directly converted to voltage without the need for an external op amp. All DAC08 series models guarantee full 8-bit monotonicity, and nonlinearities as tight as $\pm 0.1\%$ over the entire operating temperature range are available. Device performance is essentially unchanged over the ± 4.5 V to ± 18 V power supply range, with 33 mW power consumption attainable at ± 5 V supplies.

The compact size and low power consumption make the DAC08 attractive for portable and military/aerospace applications; devices processed to MIL-STD-883, Level B are available.

DAC08 applications include 8-bit, 1 μ s A/D converters, servo motor and pen drivers, waveform generators, audio encoders and attenuators, analog meter drivers, programmable power supplies, LCD display drivers, high speed modems, and other applications where low cost, high speed, and complete input/output versatility are required.

FUNCTIONAL BLOCK DIAGRAM

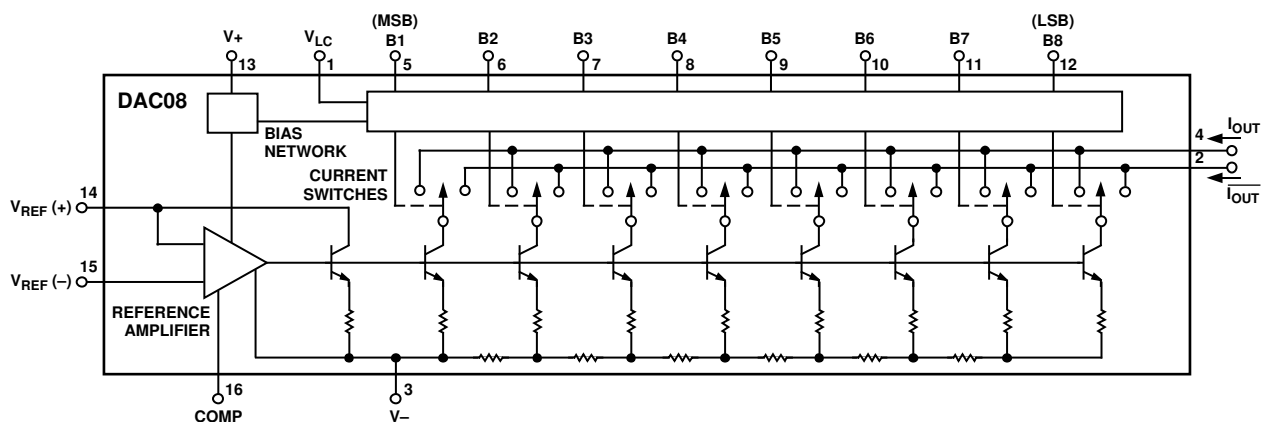

Figure 1.

00288-C-001

Rev. D

[Document Feedback](#)

Information furnished by Analog Devices is believed to be accurate and reliable. However, no responsibility is assumed by Analog Devices for its use, nor for any infringements of patents or other rights of third parties that may result from its use. Specifications subject to change without notice. No license is granted by implication or otherwise under any patent or patent rights of Analog Devices. Trademarks and registered trademarks are the property of their respective owners.

One Technology Way, P.O. Box 9106, Norwood, MA 02062-9106, U.S.A.
Tel: 781.329.4700 ©2002–2016 Analog Devices, Inc. All rights reserved.
[Technical Support](#) www.analog.com

DAC08* PRODUCT PAGE QUICK LINKS

Last Content Update: 02/23/2017

COMPARABLE PARTS

View a parametric search of comparable parts.

DOCUMENTATION

Application Notes

- AN-17: DAC08 Applications Collection
- AN-19: Differential and Multiplying D/A Converter Applications
- AN-21: 4-20 mA Digital-to-Process Current Transmitter
- AN-23: D/A Converter Generates Hyperbolic Functions
- AN-6: Single Supply Operation of the DAC08

Data Sheet

- DAC08: 8-Bit, High Speed, Multiplying D/A Converter (Universal Digital Logic Interface) Data Sheet
- DAC08: Military Data Sheet

SOFTWARE AND SYSTEMS REQUIREMENTS

- JAN to Generic Cross Reference

REFERENCE MATERIALS

Solutions Bulletins & Brochures

- Digital to Analog Converters ICs Solutions Bulletin

DESIGN RESOURCES

- DAC08 Material Declaration
- PCN-PDN Information
- Quality And Reliability
- Symbols and Footprints

DISCUSSIONS

View all DAC08 EngineerZone Discussions.

SAMPLE AND BUY

Visit the product page to see pricing options.

TECHNICAL SUPPORT

Submit a technical question or find your regional support number.

DOCUMENT FEEDBACK

Submit feedback for this data sheet.

TABLE OF CONTENTS

Features	1	Application Information.....	14
General Description	1	Reference Amplifier Setup	14
Functional Block Diagram	1	Reference Amplifier Compensation for Multiplying Applications	14
Revision History	2	Logic Inputs.....	14
Specifications.....	3	Analog Output Currents	14
Electrical Characteristics	3	Power Supplies.....	15
Typical Electrical Characteristics	4	Temperature Performance.....	15
Absolute Maximum Ratings.....	5	Multiplying Operation.....	15
Thermal Resistance	5	Settling Time.....	15
ESD Caution.....	5	Analog Devices Current Output DACs.....	17
Pin Configuration and Function Descriptions.....	6	Outline Dimensions.....	18
Test and Burn-In Circuits.....	7	Ordering Guide	19
Typical Performance Characteristics	8		
Basic Connections	11		

REVISION HISTORY

3/16—Rev. C to Rev. D

Added Thermal Resistance Section	5
Changes to Table 4.....	5
Change to Figure 29	12
Updated Outline Dimensions	18
Changes to Ordering Guide	10

11/04—Rev. B to Rev. C

Changed SO to SOIC	Universal
Removed DIE	Universal
Changes to Figure 30, Figure 31, Figure 32.....	12
Change to Figure 33	15
Added Table 4.....	16
Updated Outline Dimensions	17
Changes to Ordering Guide	18

2/02—Rev. A to Rev. B

Edits to Specifications.....	2
Edits to Absolute Maximum Ratings.....	3
Edits to Ordering Guide	3
Edits to Wafer Test Limits	5
Edit to Figure 13	8
Edits to Figures 14 and 15	9

SPECIFICATIONS

ELECTRICAL CHARACTERISTICS

$V_S = \pm 15\text{ V}$, $I_{REF} = 2.0\text{ mA}$, $-55^\circ\text{C} \leq T_A \leq +125^\circ\text{C}$ for DAC08/DAC08A, $0^\circ\text{C} \leq T_A \leq +70^\circ\text{C}$ for DAC08E and DAC08H, -40°C to $+85^\circ\text{C}$ for DAC08C, unless otherwise noted. Output characteristics refer to both I_{OUT} and \bar{I}_{OUT} .

Table 1.

Parameter	Symbol	Test Conditions/Comments	DAC08A/DAC08H			DAC08E			DAC08C			Unit
			Min	Typ	Max	Min	Typ	Max	Min	Typ	Max	
RESOLUTION			8			8			8			Bits
MONOTONICITY			8			8			8			Bits
NONLINEARITY	NL		± 0.1			± 0.19			± 0.39			%FS
SETTLING TIME	t_s	To $\pm 1/2$ LSB, all bits switched on or off, $T_A = 25^\circ\text{C}^1$	85 135			85 150			85 150			ns
PROPAGATION DELAY	Each Bit t_{PLH} All Bits Switched t_{PHL}	$T_A = 25^\circ\text{C}^1$	35 60			35 60			35 60			ns
			35 60			35 60			35 60			ns
FULL-SCALE TEMPCO ¹	TCI_{FS}	DAC08E	± 10 ± 50			± 10 ± 80 ± 50			± 10 ± 80			ppm/ $^\circ\text{C}$
OUTPUT VOLTAGE Compliance (True Compliance)	V_{OC}	Full-scale current Change $< 1/2$ LSB, $R_{OUT} > 20\text{ M}\Omega$ typ	-10 +18			-10 +18			-10 +18			V
FULL RANGE CURRENT	I_{FR4}	$V_{REF} = 10.000\text{ V}$ R14, R15 = $5.000\text{ k}\Omega$ $T_A = 25^\circ\text{C}$	1.984	1.992	2.000	1.94	1.99	2.04	1.94	1.99	2.04	mA
FULL RANGE SYMMETRY	I_{FR5}	$I_{FR4} - I_{FR2}$	± 0.5 ± 4			± 1 ± 8			± 2 ± 16			μA
ZERO-SCALE CURRENT	I_{Z5}		0.1 1			0.2 2			0.2 4			μA
OUTPUT CURRENT RANGE	I_{OR1}	R14, R15 = $5.000\text{ k}\Omega$	2.1			2.1			2.1			mA
	I_{OR2}	$V_{REF} = +15.0\text{ V}$, $V_- = -10\text{ V}$ $V_{REF} = +25.0\text{ V}$, $V_- = -12\text{ V}$	4.2			4.2			4.2			mA
OUTPUT CURRENT NOISE		$I_{REF} = 2\text{ mA}$	25			25			25			nA
LOGIC INPUT LEVELS	Logic 0 V_{IL}	$V_{LC} = 0\text{ V}$	0.8			0.8			0.8			V
	Logic 1 V_{IH}		2			2			2			V
LOGIC INPUT CURRENT	Logic 0 I_{IL}	$V_{LC} = 0\text{ V}$ $V_{IN} = -10\text{ V}$ to $+0.8\text{ V}$ $V_{IN} = 2.0\text{ V}$ to 18 V	-2 -10			-2 -10			-2 -10			μA
	Logic 1 I_{IH}		0.002 10			0.002 10			0.002 10			μA
LOGIC INPUT SWING	V_{IS}	$V_- = -15\text{ V}$	-10 +18			-10 +18			-10 +18			V
LOGIC THRESHOLD RANGE	V_{THR}	$V_S = \pm 15\text{ V}^1$	-10 +13.5			-10 +13.5			-10 +13.5			V
REFERENCE BIAS CURRENT	I_{15}		-1 -3			-1 -3			-1 -3			μA
REFERENCE INPUT	dl/dt	$R_{EQ} = 200\ \Omega$	4 8			4 8			4 8			mA/ μs
SLEW RATE		$R_L = 100\ \Omega$ $C_C = 0\text{ pF}$. See Figure 7. ¹										

Parameter	Symbol	Test Conditions/Comments	DAC08A/DAC08H			DAC08E			DAC08C			Unit
			Min	Typ	Max	Min	Typ	Max	Min	Typ	Max	
POWER SUPPLY SENSITIVITY	PSSI _{FS+}	V ₊ = 4.5 V to 18 V	±0.0003	±0.01		±0.0003	±0.01		±0.0003	±0.01		%ΔI _o / %ΔV ₊
	PSSI _{FS-}	V ₋ = -4.5 V to -18 V	±0.002	±0.01		±0.002	±0.01		±0.002	±0.01		%ΔI _o / %ΔV ₋
		I _{REF} = 1.0 mA										
POWER SUPPLY CURRENT	I ₊	V _S = ±5 V, I _{REF} = 1.0 mA	2.3	3.8		2.3	3.8		2.3	3.8		mA
	I ₋		-4.3	-5.8		-4.3	-5.8		-4.3	-5.8		mA
	I ₊	V _S = +5 V, -15 V	2.4	3.8		2.4	3.8		2.4	3.8		mA
	I ₋	I _{REF} = 2.0 mA	-6.4	-7.8		-6.4	-7.8		-6.4	-7.8		mA
	I ₊	V _S = ±15 V	2.5	3.8		2.5	3.8		2.5	3.8		mA
	I ₋	I _{REF} = 2.0 mA	-6.5	-7.8		-6.5	-7.8		-6.5	-7.8		mA
POWER DISSIPATION	P _D	±5 V, I _{REF} = 1.0 mA +5 V, -15 V	33	48		33	48		33	48		mW
		I _{REF} = 2.0 mA ±15 V, I _{REF} = 2.0 mA	108	136		103	136		108	136		mW
			135	174		135	174		135	174		mW

¹ Guaranteed by design.

TYPICAL ELECTRICAL CHARACTERISTICS

V_S = ±15 V, and I_{REF} = 2.0 mA, unless otherwise noted. Output characteristics apply to both I_{OUT} and $\overline{I_{OUT}}$.

Table 2.

Parameter	Symbol	Test Conditions/Comments	All Grades Typical	Unit
REFERENCE INPUT SLEW RATE	di/dt		8	mA/μs
PROPAGATION DELAY	t _{PLH} , t _{PHL}	T _A = 25°C, any bit	35	ns
SETTLING TIME	t _S	To ±1/2 LSB, all bits switched on or off, T _A = 25°C	85	ns

ABSOLUTE MAXIMUM RATINGS

Table 3.

Parameter	Rating
Operating Temperature	
DAC08AQ, DAC08Q	-55°C to +125°C
DAC08HQ, DAC08EQ, DAC08CQ	0°C to +70°C
DAC08CP, DAC08CS	-40°C to +85°C
Junction Temperature (T _J)	-65°C to +150°C
Storage Temperature Q Package	-65°C to +150°C
Storage Temperature P Package	-65°C to +125°C
Lead Temperature (Soldering, 60 sec)	300°C
V ₊ Supply to V ₋ Supply	36 V
Logic Inputs	V ₋ to V ₋ + 36 V
V _{IC}	V ₋ to V ₊
Analog Current Outputs (at V _{S-} = 15 V)	4.25 mA
Reference Input (V ₁₄ to V ₁₅)	V ₋ to V ₊
Reference Input Differential Voltage (V ₁₄ to V ₁₅)	±18 V
Reference Input Current (I ₁₄)	5.0 mA

Stresses at or above those listed under Absolute Maximum Ratings may cause permanent damage to the product. This is a stress rating only; functional operation of the product at these or any other conditions above those indicated in the operational section of this specification is not implied. Operation beyond the maximum operating conditions for extended periods may affect product reliability.

THERMAL RESISTANCE

θ_{JA} is specified for worst case mounting conditions, that is, θ_{JA} is specified for device in socket for CERDIP, PDIP, and LCC packages; θ_{JA} is specified for device soldered to printed circuit board for SOIC package.

Table 4. Thermal Resistance

Package Type	θ_{JA}	θ_{JC}	Unit
16-Lead CERDIP (Q)	100	16	°C/W
16-Lead PDIP (P)	82	39	°C/W
20-Terminal LCC (RC)	76	36	°C/W
16-Lead SOIC (S)	111	35	°C/W

ESD CAUTION



ESD (electrostatic discharge) sensitive device. Charged devices and circuit boards can discharge without detection. Although this product features patented or proprietary protection circuitry, damage may occur on devices subjected to high energy ESD. Therefore, proper ESD precautions should be taken to avoid performance degradation or loss of functionality.

PIN CONFIGURATION AND FUNCTION DESCRIPTIONS

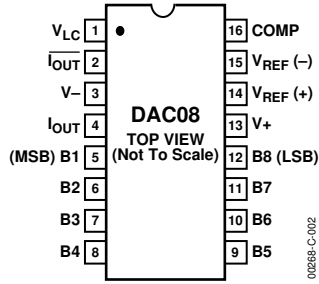

Figure 2. 16-Lead Dual In-Line Package (PDIP and CERDIP)

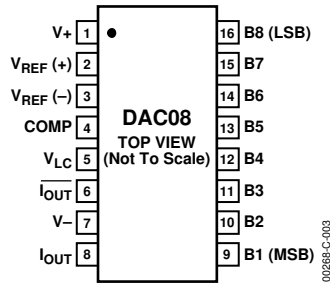

Figure 3. 16-Lead Standard Small Outline Package (SOIC_N)

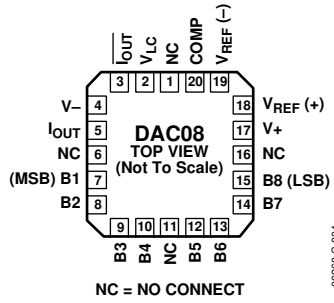

Figure 4. DAC08RC/883 20-Terminal Ceramic Leadless Chip Carrier (LCC)

TEST AND BURN-IN CIRCUITS

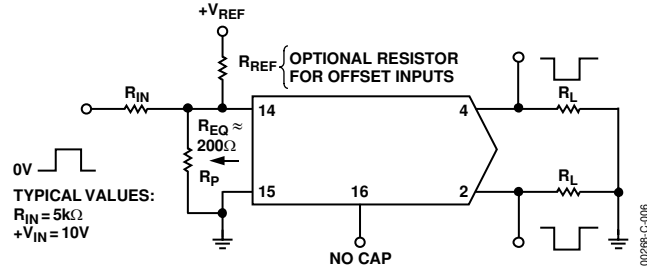

Figure 5. Pulsed Reference Operation

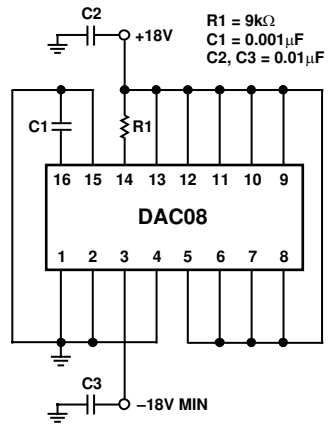

Figure 6. Burn-In Circuit

TYPICAL PERFORMANCE CHARACTERISTICS

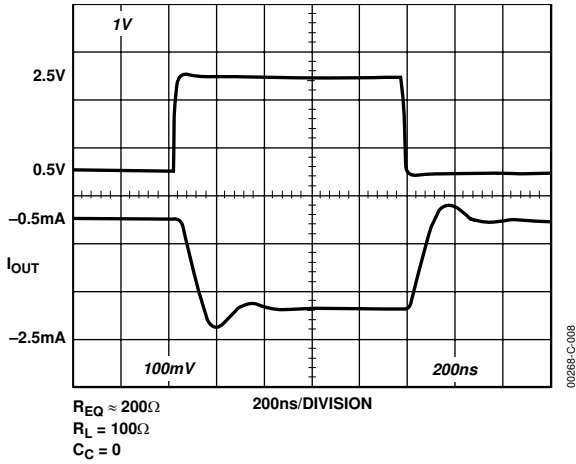

Figure 7. Fast Pulsed Reference Operation

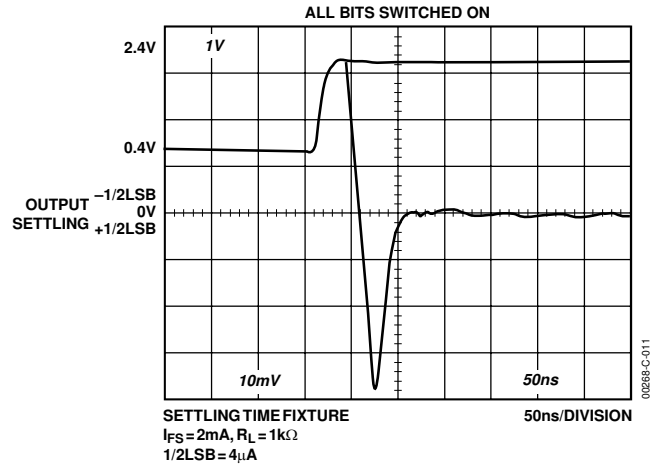

Figure 10. Full-Scale Settling Time

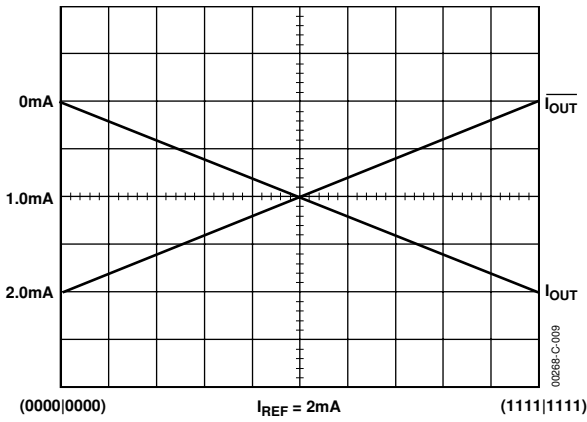

Figure 8. True and Complementary Output Operation

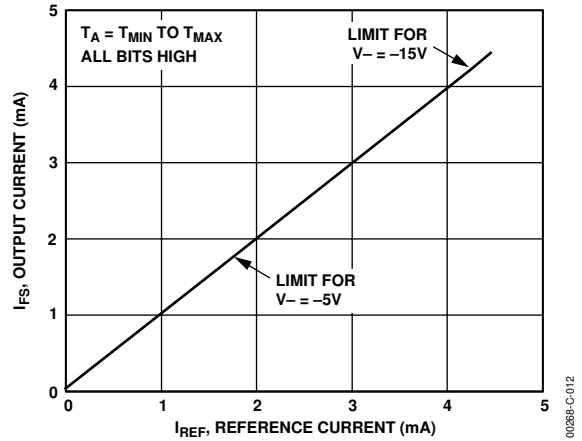

Figure 11. Full-Scale Current vs. Reference Current

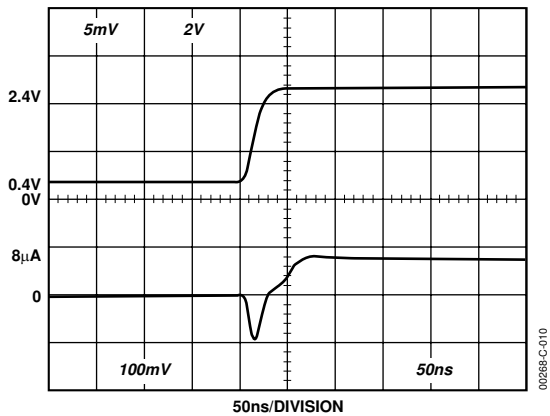

Figure 9. LSB Switching

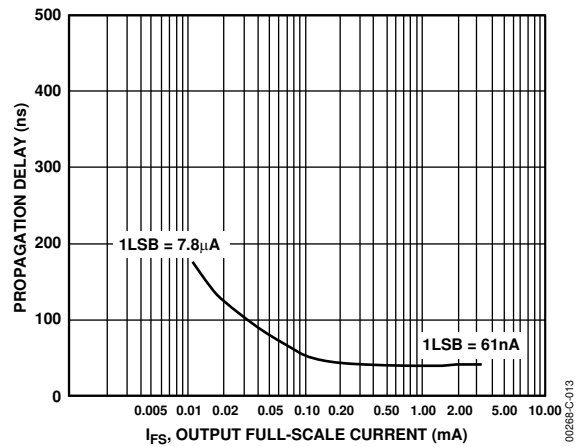

Figure 12. LSB Propagation Delay vs. IFS

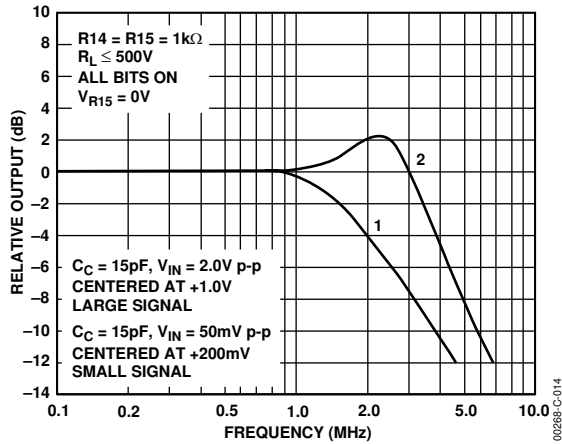

Figure 13. Reference Input Frequency Response

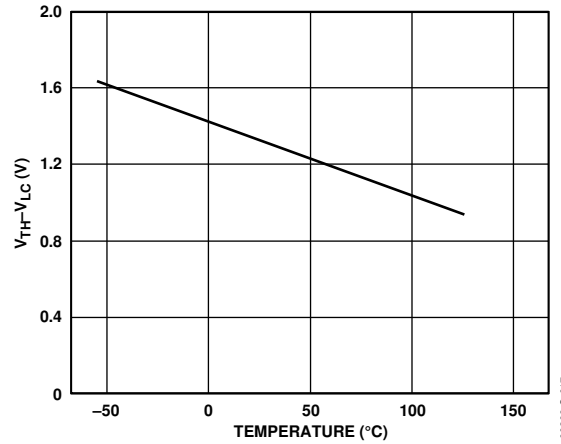

Figure 16. $V_{TH} - V_{LC}$ vs. Temperature

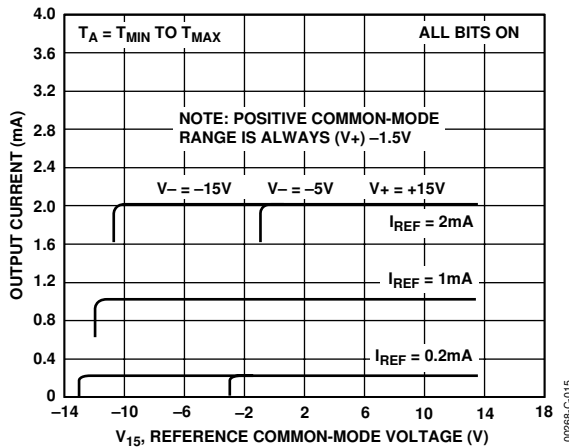

Figure 14. Reference Amplifier Common-Mode Range

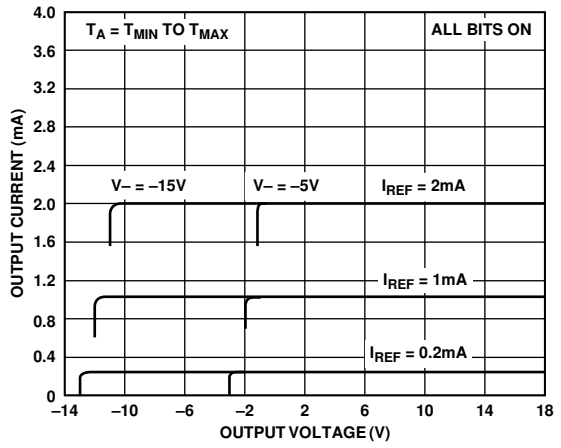

Figure 17. Output Current vs. Output Voltage (Output Voltage Compliance)

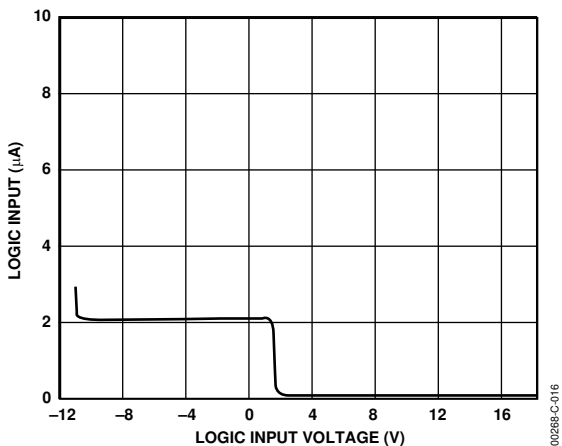

Figure 15. Logic Input Current vs. Input Voltage

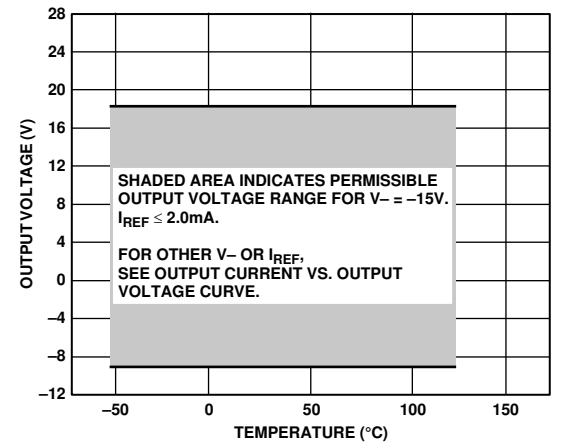
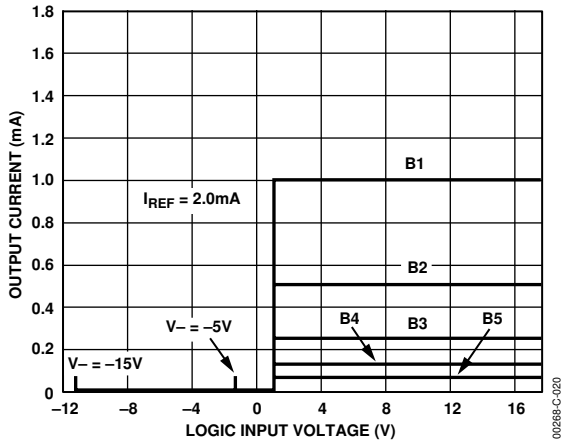

Figure 18. Output Voltage Compliance vs. Temperature



NOTE:
 B1 THROUGH B8 HAVE IDENTICAL TRANSFER CHARACTERISTICS. BITS ARE FULLY SWITCHED WITH LESS THAN 1/2 LSB ERROR, AT LESS THAN $\pm 100\text{mV}$ FROM ACTUAL THRESHOLD. THESE SWITCHING POINTS ARE GUARANTEED TO LIE BETWEEN 0.8V AND 2.0V OVER THE OPERATING TEMPERATURE RANGE ($V_{LC} = 0.0\text{V}$).

Figure 19. Bit Transfer Characteristics

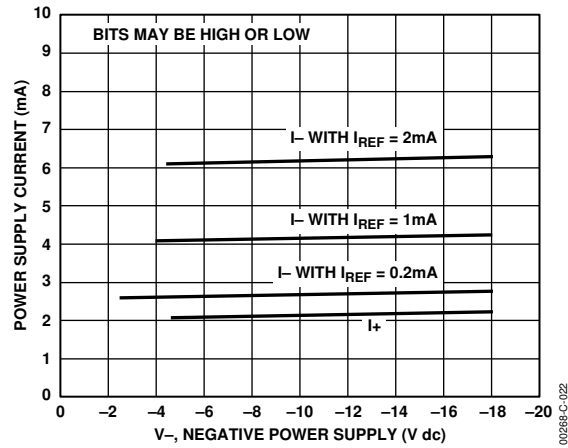

Figure 21. Power Supply Current vs. V_-

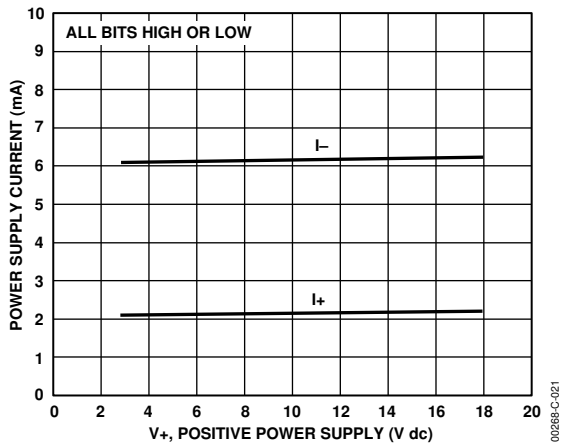

Figure 20. Power Supply vs. V_+

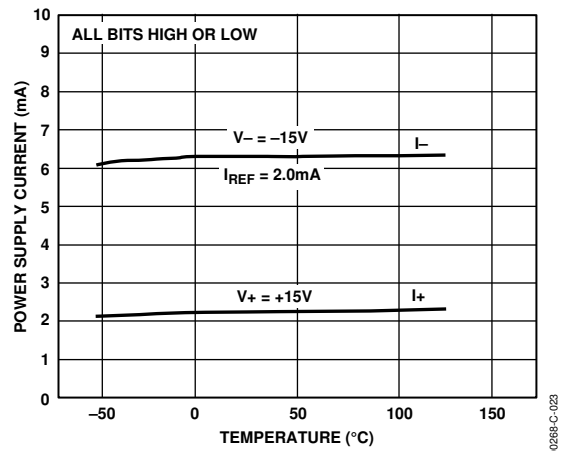

Figure 22. Power Supply Current vs. Temperature

BASIC CONNECTIONS

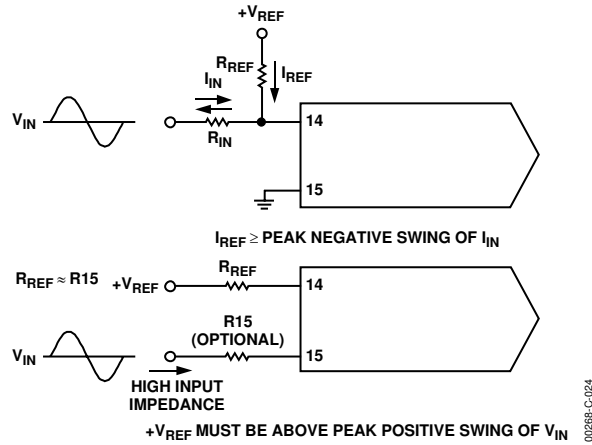

Figure 23. Accommodating Bipolar References

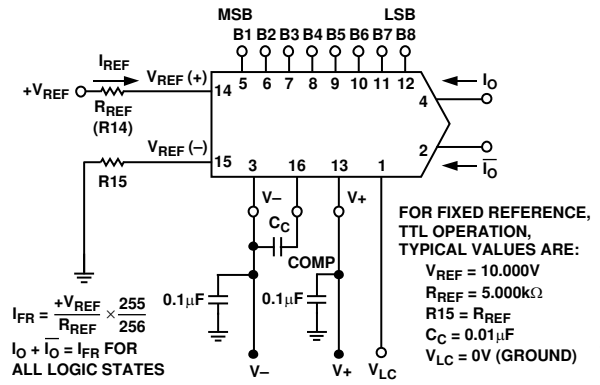

Figure 24. Basic Positive Reference Operation

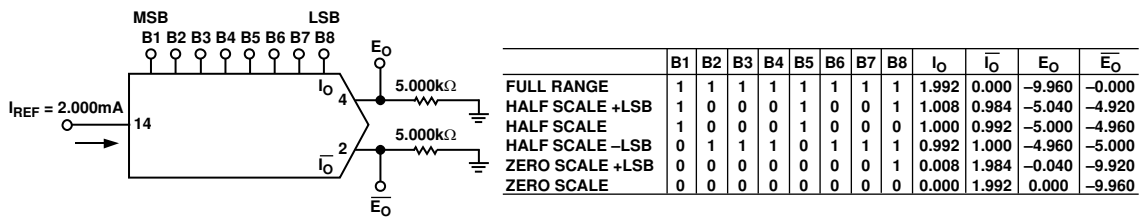

Figure 25. Basic Unipolar Negative Operation

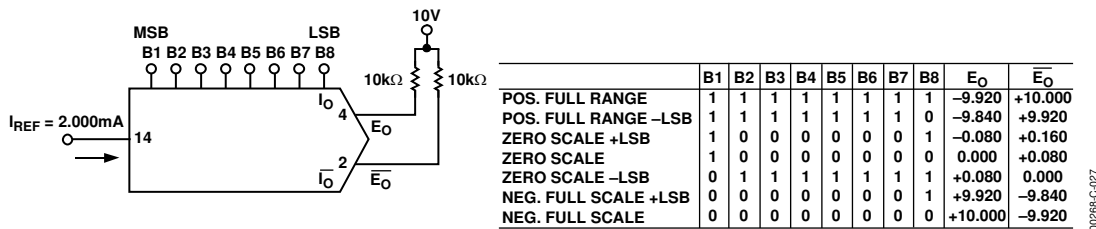

Figure 26. Basic Bipolar Output Operation

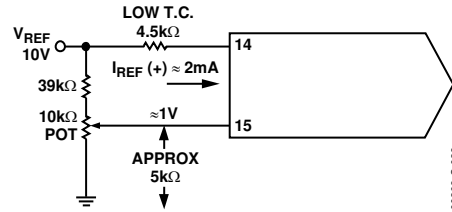

Figure 27. Recommended Full-Scale Adjustment Circuit

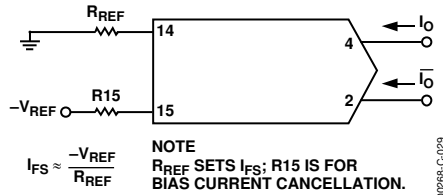

Figure 28. Basic Negative Reference Operation

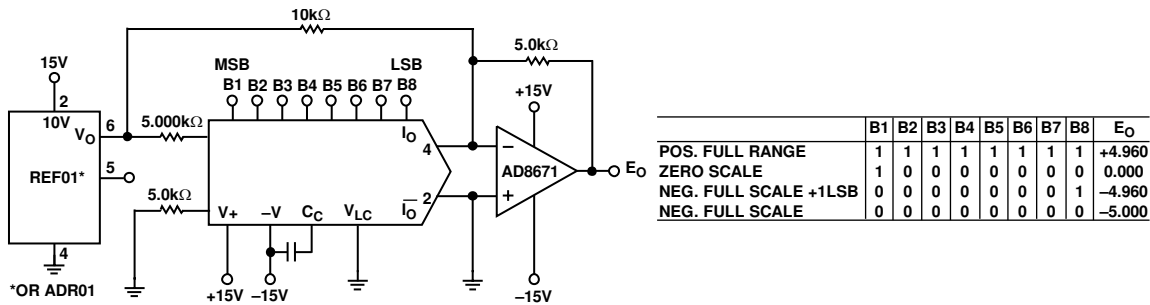
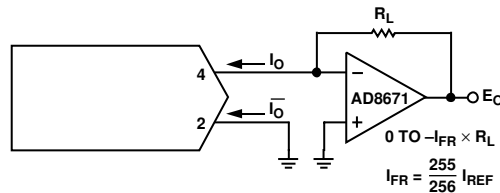
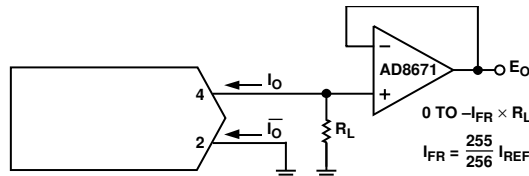

Figure 29. Offset Binary Operation



FOR COMPLEMENTARY OUTPUT (OPERATION AS A NEGATIVE LOGIC DAC), CONNECT INVERTING INPUT OF OP AMP TO I₀ (PIN 2); CONNECT I₀ (PIN 4) TO GROUND.

Figure 30. Positive Low Impedance Output Operation



FOR COMPLEMENTARY OUTPUT (OPERATION AS A NEGATIVE LOGIC DAC), CONNECT NONINVERTING INPUT OF OP AMP TO I₀ (PIN 2); CONNECT I₀ (PIN 4) TO GROUND.

Figure 31. Negative Low Impedance Output Operation

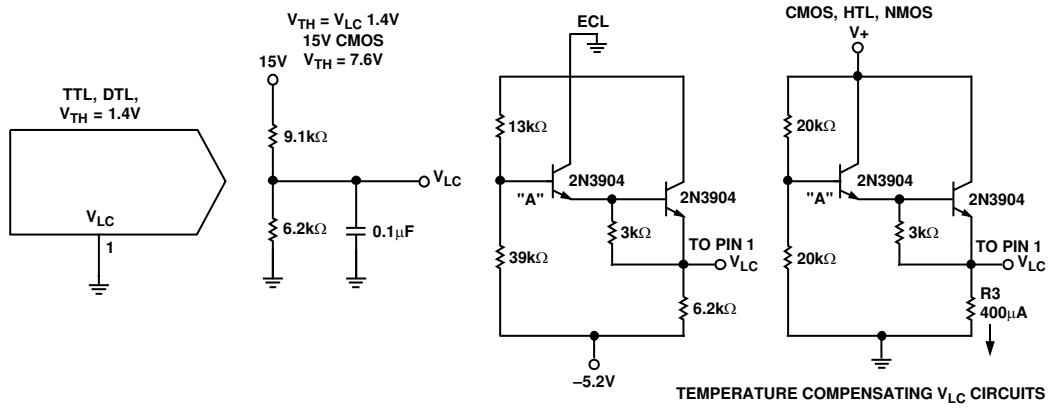

00288-C-033

Figure 32. Interfacing with Various Logic Families

APPLICATION INFORMATION

REFERENCE AMPLIFIER SETUP

The DAC08 is a multiplying D/A converter in which the output current is the product of a digital number and the input reference current. The reference current may be fixed or may vary from nearly zero to 4.0 mA. The full-scale output current is a linear function of the reference current and is given by

$$I_{FR} = \frac{255}{256} \times I_{REF}$$

where $I_{REF} = I_{14}$

In positive reference applications, an external positive reference voltage forces current through R14 into the $V_{REF(+)}$ terminal (Pin 14) of the reference amplifier. Alternatively, a negative reference may be applied to $V_{REF(-)}$ at Pin 15; reference current flows from ground through R14 into $V_{REF(+)}$ as in the positive reference case. This negative reference connection has the advantage of a very high impedance presented at Pin 15. The voltage at Pin 14 is equal to and tracks the voltage at Pin 15 due to the high gain of the internal reference amplifier. R15 (nominally equal to R14) cancels bias current errors; R15 may be eliminated with only a minor increase in error.

Bipolar references may be accommodated by offsetting V_{REF} or Pin 15. The negative common-mode range of the reference amplifier is given by $V_{CM-} = V_-$ plus $(I_{REF} \times 1 \text{ k}\Omega)$ plus 2.5 V. The positive common-mode range is V_+ less 1.5 V.

When a dc reference is used, a reference bypass capacitor is recommended. A 5.0 V TTL logic supply is not recommended as a reference. If a regulated power supply is used as a reference, R14 must be split into two resistors with the junction bypassed to ground with a 0.1 μF capacitor.

For most applications, the tight relationship between I_{REF} and I_{FS} eliminates the need for trimming I_{REF} . If required, full-scale trimming can be accomplished by adjusting the value of R14, or by using a potentiometer for R14. An improved method of full-scale trimming that eliminates potentiometer T.C. effects is shown in the recommended full-scale adjustment circuit (Figure 27).

Using lower values of reference current reduces negative power supply current and increases reference amplifier negative common-mode range. The recommended range for operation with a dc reference current is 0.2 mA to 4.0 mA.

REFERENCE AMPLIFIER COMPENSATION FOR MULTIPLYING APPLICATIONS

AC reference applications require the reference amplifier to be compensated using a capacitor from Pin 16 to V_- . The value of this capacitor depends on the impedance presented to Pin 14; for R14 values of 1.0 k Ω , 2.5 k Ω , and 5.0 k Ω , minimum values of C_C are 15 pF, 37 pF, and 75 pF. Larger values of R14 require proportionately increased values of C_C for proper phase margin, so the ratio of C_C (pF) to R14 (k Ω) = 15.

For fastest response to a pulse, low values of R14 enabling small C_C values must be used. If Pin 14 is driven by a high impedance such as a transistor current source, none of the preceding values suffice, and the amplifier must be heavily compensated, which decreases overall bandwidth and slew rate. For R14 = 1 k Ω and $C_C = 15$ pF, the reference amplifier slews at 4 mA/ μs , enabling a transition from $I_{REF} = 0$ to $I_{REF} = 2$ mA in 500 ns.

Operation with pulse inputs to the reference amplifier can be accommodated by an alternate compensation scheme. This technique provides lowest full-scale transition times. An internal clamp allows quick recovery of the reference amplifier from a cutoff ($I_{REF} = 0$) condition. Full-scale transition (0 mA to 2 mA) occurs in 120 ns when the equivalent impedance at Pin 14 is 200 Ω and $C_C = 0$. This yields a reference slew rate of 16 mA/ μs , which is relatively independent of the R_{IN} and V_{IN} values.

LOGIC INPUTS

The DAC08 design incorporates a unique logic input circuit that enables direct interface to all popular logic families and provides maximum noise immunity. This feature is made possible by the large input swing capability, 2 μA logic input current, and completely adjustable logic threshold voltage. For $V_- = -15$ V, the logic inputs may swing between -10 V and $+18$ V. This enables direct interface with 15 V CMOS logic, even when the DAC08 is powered from a 5 V supply. Minimum input logic swing and minimum logic threshold voltage are given by

$$V_- + (I_{REF} \times 1 \text{ k}\Omega) + 2.5 \text{ V}$$

The logic threshold may be adjusted over a wide range by placing an appropriate voltage at the logic threshold control pin (Pin 1, V_{LC}). Figure 16 shows the relationship between V_{LC} and V_{TH} over the temperature range, with V_{TH} nominally 1.4 above V_{LC} . For TTL and DTL interface, simply ground Pin 1. When interfacing ECL, an $I_{REF} = 1$ mA is recommended. For interfacing other logic families, see Figure 32. For general set-up of the logic control circuit, note that Pin 1 sources 100 μA typical; external circuitry must be designed to accommodate this current.

Fastest settling times are obtained when Pin 1 sees a low impedance. If Pin 1 is connected to a 1 k Ω divider, for example, it must be bypassed to ground by a 0.01 μF capacitor.

ANALOG OUTPUT CURRENTS

Both true and complemented output sink currents are provided where $I_O + \bar{I}_O = I_{FS}$. Current appears at the true (I_O) output when a 1 (logic high) is applied to each logic input. As the binary count increases, the sink current at Pin 4 increases proportionally, in the fashion of a positive logic DAC. When a 0 is applied to any input bit, that current is turned off at Pin 4 and turned on at Pin 2. A decreasing logic count increases \bar{I}_O as in a negative or inverted logic DAC. Both outputs may be used simultaneously.

If one of the outputs is not required, it must be connected to ground or to a point capable of sourcing I_{FS} ; do not leave an unused output pin open.

Both outputs have an extremely wide voltage compliance enabling fast direct current to voltage conversion through a resistor tied to ground or other voltage source. Positive compliance is 36 V above V_- and is independent of the positive supply. Negative compliance is given by

$$V_- + (I_{REF} \times 1 \text{ k}\Omega) + 2.5 \text{ V}$$

The dual outputs enable double the usual peak-to-peak load swing when driving loads in quasi-differential fashion. This feature is especially useful in cable driving, CRT deflection and in other balanced applications such as driving center-tapped coils and transformers.

POWER SUPPLIES

The DAC08 operates over a wide range of power supply voltages from a total supply of 9 V to 36 V. When operating at supplies of ± 5 V or lower, $I_{REF} \leq 1$ mA is recommended. Low reference current operation decreases power consumption and increases negative compliance (Figure 11), reference amplifier negative common-mode range (Figure 14), negative logic input range (Figure 15), and negative logic threshold range (Figure 16). For example, operation at -4.5 V with $I_{REF} = 2$ mA is not recommended because negative output compliance reduces to near zero. Operation from lower supplies is possible; however, at least 8 V total must be applied to ensure turn on of the internal bias network.

Symmetrical supplies are not required, as the DAC08 is quite insensitive to variations in supply voltage. Battery operation is feasible because no ground connection is required; however, an artificial ground can ensure logic swings, etc., remain between acceptable limits. Power consumption is calculated as follows:

$$P_D = (I_+)(V_+) + (I_-)(V_-)$$

A useful feature of the DAC08 design is that supply current is constant and independent of input logic states. This is useful in cryptographic applications and further reduces the size of the power supply bypass capacitors.

TEMPERATURE PERFORMANCE

The nonlinearity and monotonicity specifications of the DAC08 are guaranteed to apply over the entire rated operating temperature range. Full-scale output current drift is low, typically ± 10 ppm/ $^{\circ}\text{C}$, with zero-scale output current and drift essentially negligible compared to 1/2 LSB.

The temperature coefficient of the reference resistor R14 must match and track that of the output resistor for minimum overall full-scale drift. Settling times of the DAC08 decrease approximately 10% at -55°C . At $+125^{\circ}\text{C}$, an increase of about 15% is typical.

The reference amplifier must be compensated by using a capacitor from Pin 16 to V_- . For fixed reference operation, a 0.01 μF capacitor is recommended. For variable reference applications, refer to the Reference Amplifier Compensation for Multiplying Applications section.

MULTIPLYING OPERATION

The DAC08 provides excellent multiplying performance with an extremely linear relationship between I_{FS} and I_{REF} over a range of 4 μA to 4 mA. Monotonic operation is maintained over a typical range of I_{REF} from 100 μA to 4.0 mA.

SETTLING TIME

The DAC08 is capable of extremely fast settling times, typically 85 ns at $I_{REF} = 2.0$ mA. Judicious circuit design and careful board layout must obtain full performance potential during testing and application. The logic switch design enables propagation delays of only 35 ns for each of the 8 bits. Settling time to within 1/2 LSB of the LSB is therefore 35 ns, with each progressively larger bit taking successively longer. The MSB settles in 85 ns, thus determining the overall settling time of 85 ns. Settling to 6-bit accuracy requires about 65 ns to 70 ns. The output capacitance of the DAC08, including the package, is approximately 15 pF; therefore the output RC time constant dominates settling time if $R_L > 500 \Omega$.

Settling time and propagation delay are relatively insensitive to logic input amplitude and rise and fall times, due to the high gain of the logic switches. Settling time also remains essentially constant for I_{REF} values. The principal advantage of higher I_{REF} values lies in the ability to attain a given output level with lower load resistors, thus reducing the output RC time constant.

Measuring the settling time requires the ability to accurately resolve $\pm 4 \mu\text{A}$; therefore a 1 k Ω load is needed to provide adequate drive for most oscilloscopes. The settling time fixture shown in Figure 33 uses a cascade design to permit driving a 1 k Ω load with less than 5 pF of parasitic capacitance at the measurement node. At I_{REF} values of less than 1.0 mA, excessive RC damping of the output is difficult to prevent while maintaining adequate sensitivity. However, the major carry from 01111111 to 10000000 provides an accurate indicator of settling time. This code change does not require the normal 6.2 time constants to settle to within $\pm 0.2\%$ of the final value, and thus settling time is observed at lower values of I_{REF} .

DAC08 switching transients or “glitches” are very low and can be further reduced by small capacitive loads at the output at a minor sacrifice in settling time. Fastest operation can be obtained by using short leads, minimizing output capacitance and load resistor values, and by adequate bypassing at the supply, reference, and V_{LC} terminals. Supplies do not require large electrolytic bypass capacitors because the supply current drain is independent of input logic states; 0.1 μF capacitors at the supply pins provide full transient protection.

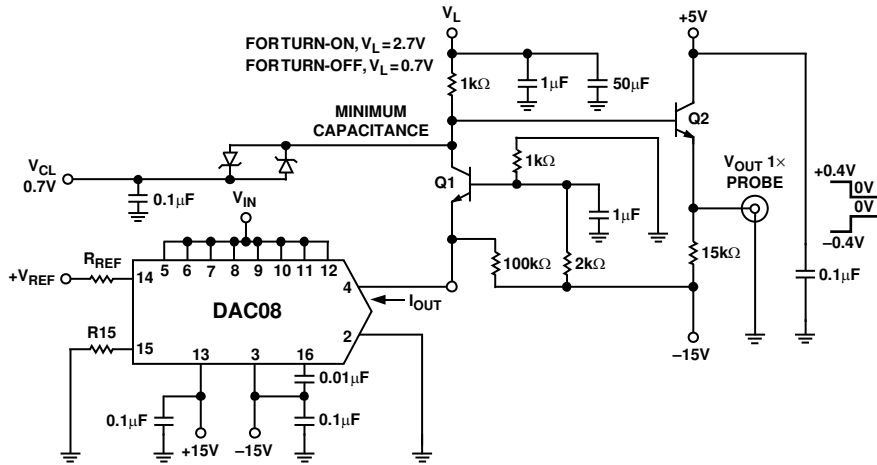

Figure 33. Settling Time Measurement

00288-C-034

ANALOG DEVICES, INC., CURRENT OUTPUT DACs

Table 4 lists the latest DACs available from Analog Devices.

Table 5.

Model	Bits	Outputs	Interface	Package	Comments
AD5425	8	1	SPI, 8-bit load	MSOP-10	Fast 8-bit load; see also AD5426
AD5426	8	1	SPI	MSOP-10	See also AD5425 fast load
AD5450	8	1	SPI	SOT23-8	See also AD5425 fast load
AD5424	8	1	Parallel	TSSOP-16	
AD5429	8	2	SPI	TSSOP-16	
AD5428	8	2	Parallel	TSSOP-20	
AD5432	10	1	SPI	MSOP-10	
AD5451	10	1	SPI	SOT23-8	
AD5433	10	1	Parallel	TSSOP-20	
AD5439	10	2	SPI	TSSOP-16	
AD5440	10	2	Parallel	TSSOP-24	
AD5443	12	1	SPI	MSOP-10	See also AD5452 and AD5444
AD5452	12	1	SPI	SOT23-8	Higher accuracy version of AD5443 ; see also AD5444
AD5445	12	1	Parallel	TSSOP-20	
AD5444	12	1	SPI	MSOP-10	Higher accuracy version of AD5443 ; see also AD5452
AD5449	12	2	SPI	TSSOP-16	
AD5415	12	2	SPI	TSSOP-24	Uncommitted resistors
AD5447	12	2	Parallel	TSSOP-24	
AD5405	12	2	Parallel	LFCSP-40	Uncommitted resistors
AD5453	14	1	SPI	SOT23-8	
AD5553	14	1	SPI	MSOP-8	
AD5556	14	1	Parallel	TSSOP-28	
AD5446	14	1	SPI	MSOP-10	MSOP version of AD5453 ; compatible with AD5443 , AD5432 , and AD5426
AD5555	14	2	SPI	TSSOP-16	
AD5557	14	2	Parallel	TSSOP-38	
AD5543	16	1	SPI	MSOP-8	
AD5546	16	1	Parallel	TSSOP-28	
AD5545	16	2	SPI	TSSOP-16	
AD5547	16	2	Parallel	TSSOP-38	

OUTLINE DIMENSIONS

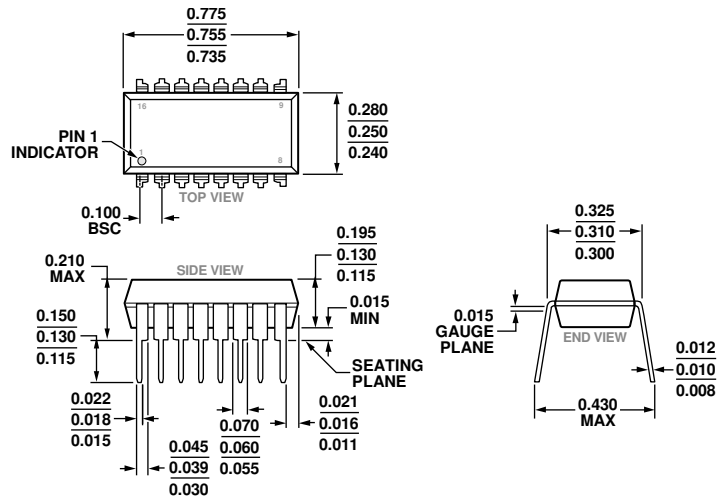

COMPLIANT TO JEDEC STANDARDS MS-001-BB

Figure 34. 16-Lead Plastic Dual In-Line Package [PDIP]
Narrow Body
(N-16)

Dimensions shown in inches

05-07-2014-D

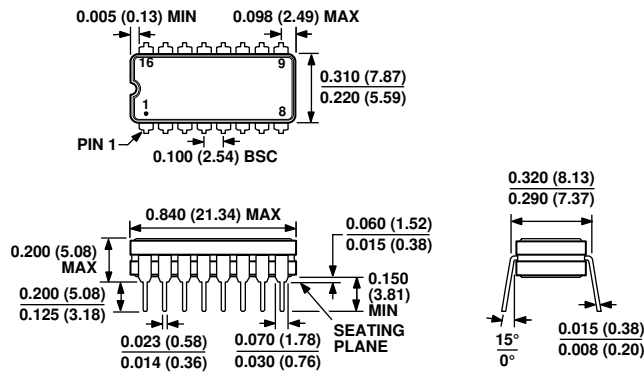

CONTROLLING DIMENSIONS ARE IN INCHES; MILLIMETER DIMENSIONS (IN PARENTHESES) ARE ROUNDED-OFF INCH EQUIVALENTS FOR REFERENCE ONLY AND ARE NOT APPROPRIATE FOR USE IN DESIGN.

Figure 35. 16-Lead Ceramic Dual In-Line Package [CERDIP]
(Q-16)

Dimensions shown in inches and (millimeters)

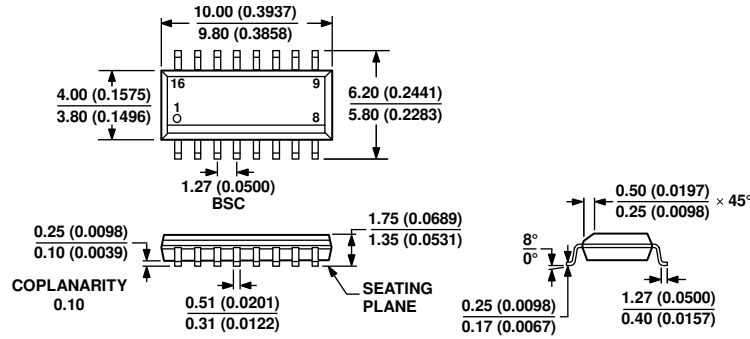

COMPLIANT TO JEDEC STANDARDS MS-012-AC
 CONTROLLING DIMENSIONS ARE IN MILLIMETERS; INCH DIMENSIONS (IN PARENTHESES) ARE ROUNDED-OFF MILLIMETER EQUIVALENTS FOR REFERENCE ONLY AND ARE NOT APPROPRIATE FOR USE IN DESIGN.

080606-A

Figure 36. 16-Lead Standard Small Outline Package [SOIC_N] Narrow Body (R-16)

Dimensions shown in millimeters and (inches)

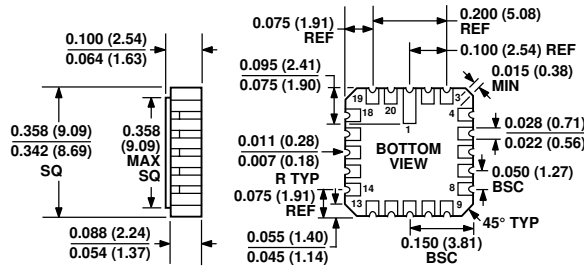

CONTROLLING DIMENSIONS ARE IN INCHES; MILLIMETERS DIMENSIONS (IN PARENTHESES) ARE ROUNDED-OFF INCH EQUIVALENTS FOR REFERENCE ONLY AND ARE NOT APPROPRIATE FOR USE IN DESIGN

Figure 37. 20-Terminal Ceramic Leadless Chip Carrier [LCC] (E-20-1)

Dimensions shown in inches and (millimeters)

ORDERING GUIDE

Model ^{1, 2, 3}	NL	Temperature Range	Package Description	Package Option	No. Parts Per Container
DAC08AQ	±0.10%	-55°C to +125°C	16-Lead Cerdip	Q-16	25
DAC08AQ/883C	±0.10%	-55°C to +125°C	16-Lead Cerdip	Q-16	25
DAC08HQ	±0.10%	0°C to 70°C	16-Lead Cerdip	Q-16	25
DAC08Q	±0.19%	-55°C to +125°C	16-Lead Cerdip	Q-16	25
DAC08RC/883C	±0.19%	-55°C to +125°C	20-Terminal LCC	E-20-1	55
DAC08EQ	±0.19%	0°C to 70°C	16-Lead Cerdip	Q-16	25
DAC08ES	±0.19%	0°C to 70°C	16-Lead SOIC	R-16	47
DAC08ESZ	±0.19%	0°C to 70°C	16-Lead SOIC	R-16	47
DAC08ESZ-REEL	±0.19%	0°C to 70°C	16-Lead SOIC	R-16	2500
DAC08CP	±0.39%	-40°C to +85°C	16-Lead PDIP	N-16	25
DAC08CPZ	±0.39%	-40°C to +85°C	16-Lead PDIP	N-16	25
DAC08CS	±0.39%	-40°C to +85°C	16-Lead SOIC	R-16	47
DAC08CS-REEL	±0.39%	-40°C to +85°C	16-Lead SOIC	R-16	2500
DAC08CSZ	±0.39%	-40°C to +85°C	16-Lead SOIC	R-16	47
DAC08CSZ-REEL	±0.39%	-40°C to +85°C	16-Lead SOIC	R-16	2500
DAC08EPZ	±0.19%	0°C to 70°C	16-Lead PDIP	N-16	25

¹ Devices processed in total compliance to MIL-STD-883. Consult the factory for the 883 data sheet.

² For availability and burn-in information on the SOIC package, contact your local sales office.

³ Z = RoHS Compliant Part.

NOTES

NOTES