



Chipsmall Limited consists of a professional team with an average of over 10 year of expertise in the distribution of electronic components. Based in Hongkong, we have already established firm and mutual-benefit business relationships with customers from,Europe,America and south Asia,supplying obsolete and hard-to-find components to meet their specific needs.

With the principle of “Quality Parts,Customers Priority,Honest Operation,and Considerate Service”,our business mainly focus on the distribution of electronic components. Line cards we deal with include Microchip,ALPS,ROHM,Xilinx,Pulse,ON,Everlight and Freescale. Main products comprise IC,Modules,Potentiometer,IC Socket,Relay,Connector.Our parts cover such applications as commercial,industrial, and automotives areas.

We are looking forward to setting up business relationship with you and hope to provide you with the best service and solution. Let us make a better world for our industry!



Contact us

Tel: +86-755-8981 8866 Fax: +86-755-8427 6832

Email & Skype: info@chipsmall.com Web: www.chipsmall.com

Address: A1208, Overseas Decoration Building, #122 Zhenhua RD., Futian, Shenzhen, China



Innovation in power conversion

PoE Interface

L1
10 μ H
1 A

C4
1000 pF
1500 V
R7
10 k

Product Selector Guide

DC-DC Products

September 2008



Features & Benefits

The DPA-Switch Family combines a 220 V power MOSFET with a controller that provides current monitoring, undervoltage and over temperature protection, soft start and other control functions in a single device, saving up to 30 external components in the power supply design. Combining the key switching elements into a single package reduces design complexity and ensures rapid, low-risk development of highly cost-effective power supplies.

Superior Performance and Flexibility. The DPA-Switch family supports a range of power requirements in either forward or flyback topologies and offers a variety of package options to maximize design flexibility. A DIP-8 package is available for low-cost designs, and a thermally efficient TO-263-7C R package (2 °C/Watt) is available for higher power applications.

Product Highlights

- Supports flyback and forward topology
- Programmable internal current sense eliminates external sense components
- Built-in auto-restart for output overload/open loop protection
- Line undervoltage (UV) detection: meets ETSI standards
- Line overvoltage (OV) shutdown protection
- Fully integrated soft-start for minimum stress/overshoot
- Hysteretic thermal shutdown for over temperature protection and automatic recovery
- Source connected tab for low EMI

EcoSmart® Energy Efficiency

- Extremely low consumption at no-load (10 mA typ.) and in remote off (2 mA max.)
- Cycle skipping at light load for high standby efficiency



Package Information

- P and G packages have Pb-free finish (100% matte tin), are RoHS compliant and meet requirements of JEDEC standard J-STD-020C table 4.2. The R package is not available in Pb-free finish.

G-Package

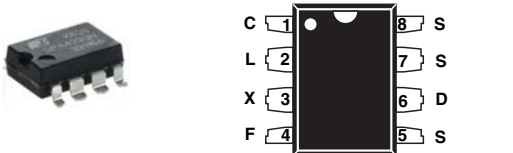

P-Package

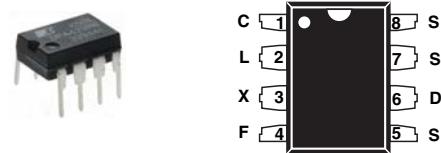

R-Package

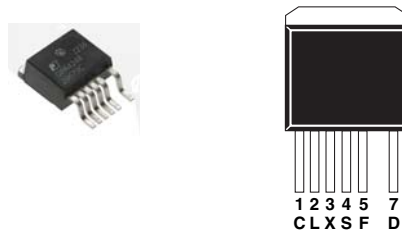

Typical Applications

- PoE applications: VoIP phones, WLAN, security cameras
- Telco central office equipment: xDSL, ISDN, PABX
- Distributed power architectures (24 V/48 V bus)
- Industrial controls
- LED lighting

Product Selector Guide

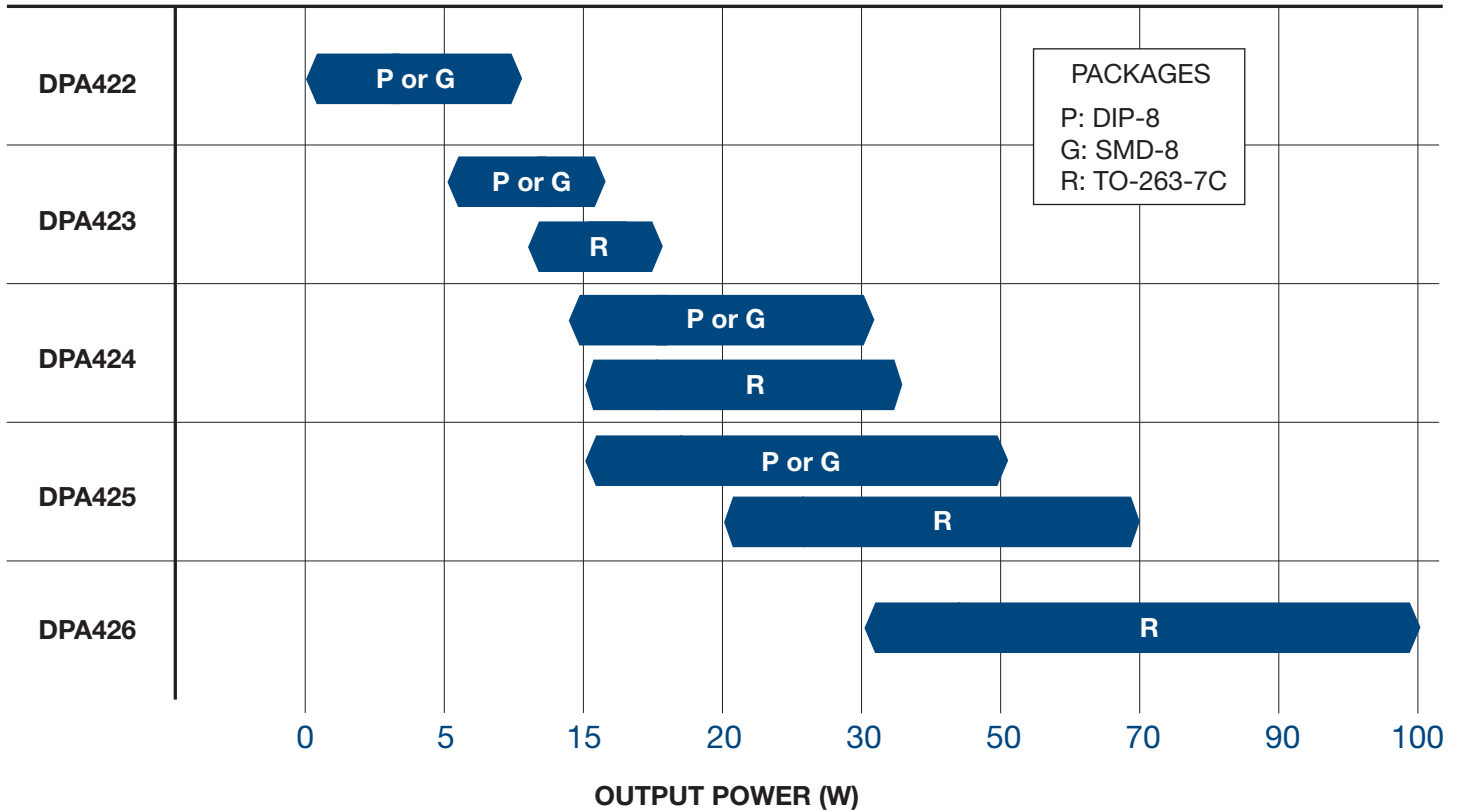

24 V / 48 V DC-DC Power Conversion (Up to 100 W)

Output Power Table

Total Device Dissipation ³ PRODUCT ⁴	36-75 VDC Input Range (Forward) ²					
	0.5 W	1 W	2.5 W	4 W	6 W	Max Power Output ¹
DPA422 ⁷	7.5 W	10 W	-	-	-	10 W
DPA423	12 W	16 W	-	-	-	18 W
DPA424	16 W	23 W	35 W	-	-	35 W
DPA425	23 W	32 W	50 W	62 W	-	70 W
DPA426 ⁵	25 W	35 W	55 W	70 W	83 W	100 W

Total Device Dissipation ³ PRODUCT ⁴	36-75 VDC Input Range (Flyback) ²				
	0.5 W	0.75 W	1 W	1.5 W	Max Power Output ¹
DPA422 ⁷	6.5 W	9 W	-	-	9 W
DPA423	9 W	13 W	-	-	13 W
DPA424	10 W	14.5 W	18 W	24 W	26 W
DPA425	- ⁶	- ⁶	- ⁶	25.5 W	52 W

Notes:
1. Maximum output power is limited by device internal current limit. 2. See Applications Considerations section of the DPA-Switch data sheet for complete description of assumptions and for output powers with other input voltage ranges. 3. For device dissipation of 1.5 W or below, use P or G packages. Device dissipation above 1.5 W is possible with R packages. 4. Packages: P: DIP-8, G: SMD-8, R: TO-263-7C. For lead-free package options, see Part Ordering section of the DPA-Switch data sheet. 5. Available in R package only. 6. Due to higher switching losses, the DPA425 may not deliver additional power compared to a smaller device. 7. Available in P and G package only.

Integrated Features

HV-FET Rating	220 V	Soft Start	✓	Hysteretic Thermal Shutdown	✓	Remote ON/OFF	✓
Switching Frequency (kHz)	400/ 300	Fully Integrated Current Sensing	✓	Power Limiting	✓	EcoSmart® Low Standby/ No-load Power Consumption	✓
Max. Duty Cycle (DC _{MAX})	75%	Adjustable Current Limit	✓	Line UV Detection	✓	Synchronizable to Lower External Clock Frequency	✓
Control Method	PWM	Auto Restart	✓	Line OV Detection	✓	Remote ON/OFF	✓

DPA-Switch in PoE Applications

Power over Ethernet (PoE) is a method whereby power is transmitted to Ethernet-connected equipment (VoIP telephones, WLAN transmitters, security cameras) from the central switch. Power Integrations has developed circuits for highly cost-effective IEEE802.3af compliant power supplies. Tested by the University of New Hampshire's Interoperability Consortium (UNH-IOC), PI solutions have been shown to work with all available Power Sourcing Equipment (PSE). The results of the UNH-IOC testing are shown on the PI website.

Operation: PoE Powered Device (PD) fulfills three functions to work in conjunction with the sending end PSE: detection, classification and undervoltage lockout.

Detection Phase: The PSE checks the PD to determine if it is PoE-enabled. During the detection phase, the PSE applies a voltage ramp to the PD and looks for a characteristic impedance from the load (25 kΩ). If the signature impedance is detected, the PSE moves on to the classification phase. The signature identification voltage is a ramp voltage between 2.5 V and 10 V. A 24.9 kΩ resistor provides the correct signature impedance for detection.

Classification Phase: The PSE continues to ramp the voltage to the PD. Between 14.5 V and 20.5 V, the PD must draw a specified current to identify the device class. The classification current describes the amount of power the PD will require during normal operation. A table of classification current and operating PD power requirements is shown below.

Classification Power Levels

Class	Power (Min)	Power (Max)	Class (Min)	I _{CLASS} (Max)
0	0.44 W	12.95 W	0 mA	4 mA
1	0.44 W	3.84 W	9 mA	12 mA
2	3.84 W	6.49 W	17 mA	20 mA
3	6.49 W	12.95 W	26 mA	30 mA
4	Reserved	Reserved	36 mA	44 mA

Table 1. Classification Power Levels.

PoE Class 0 Interface with MOSFET Pass-Switch

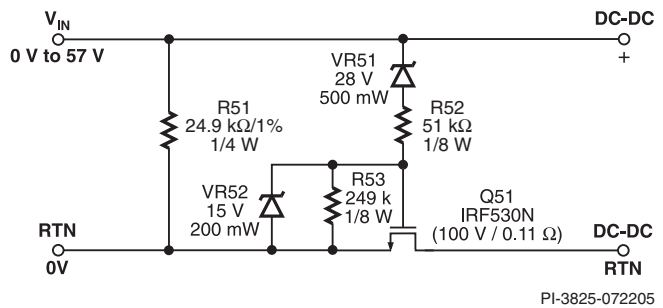

PI-3825-072205

Figure 1. PoE Class 0 Interface Circuit Using a MOSFET Pass-Switch.

Turn-on Phase: The PSE continues to ramp the input voltage up to 30 V. When the undervoltage lockout (UVLO) circuit is released the PD is allowed to power up. A typical undervoltage lockout circuit is shown in the Figure above.

For additional information see Design Ideas DI-70 (www.powerint.com/PDFFiles/di70.pdf) & DI-88 (www.powerint.com/PDFFiles/di88.pdf), also Reference Design Kits DAK-68A and DAK-86.

DPA-Switch – Constant Current LED Driver (10 W, 500 mA)

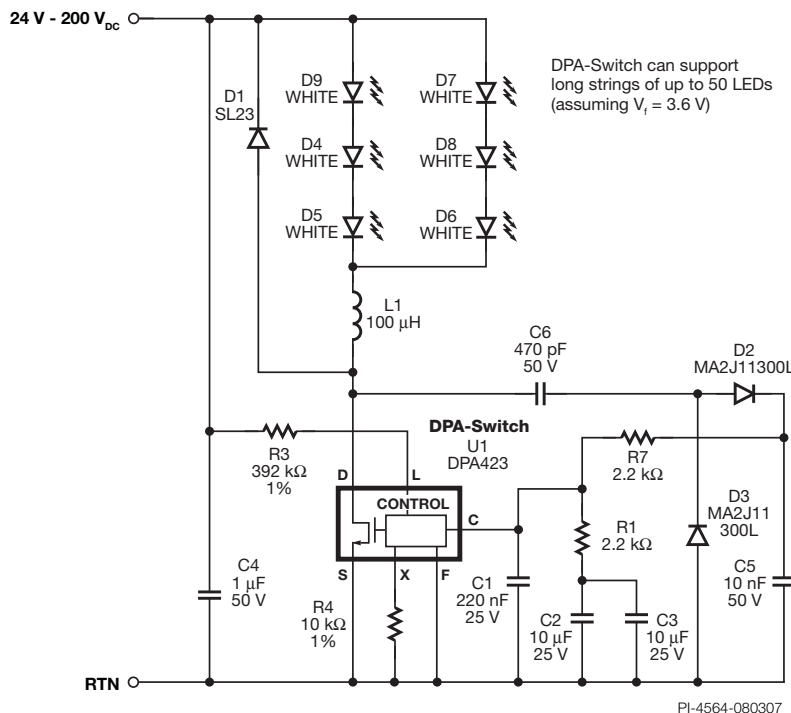

PI-4564-080307

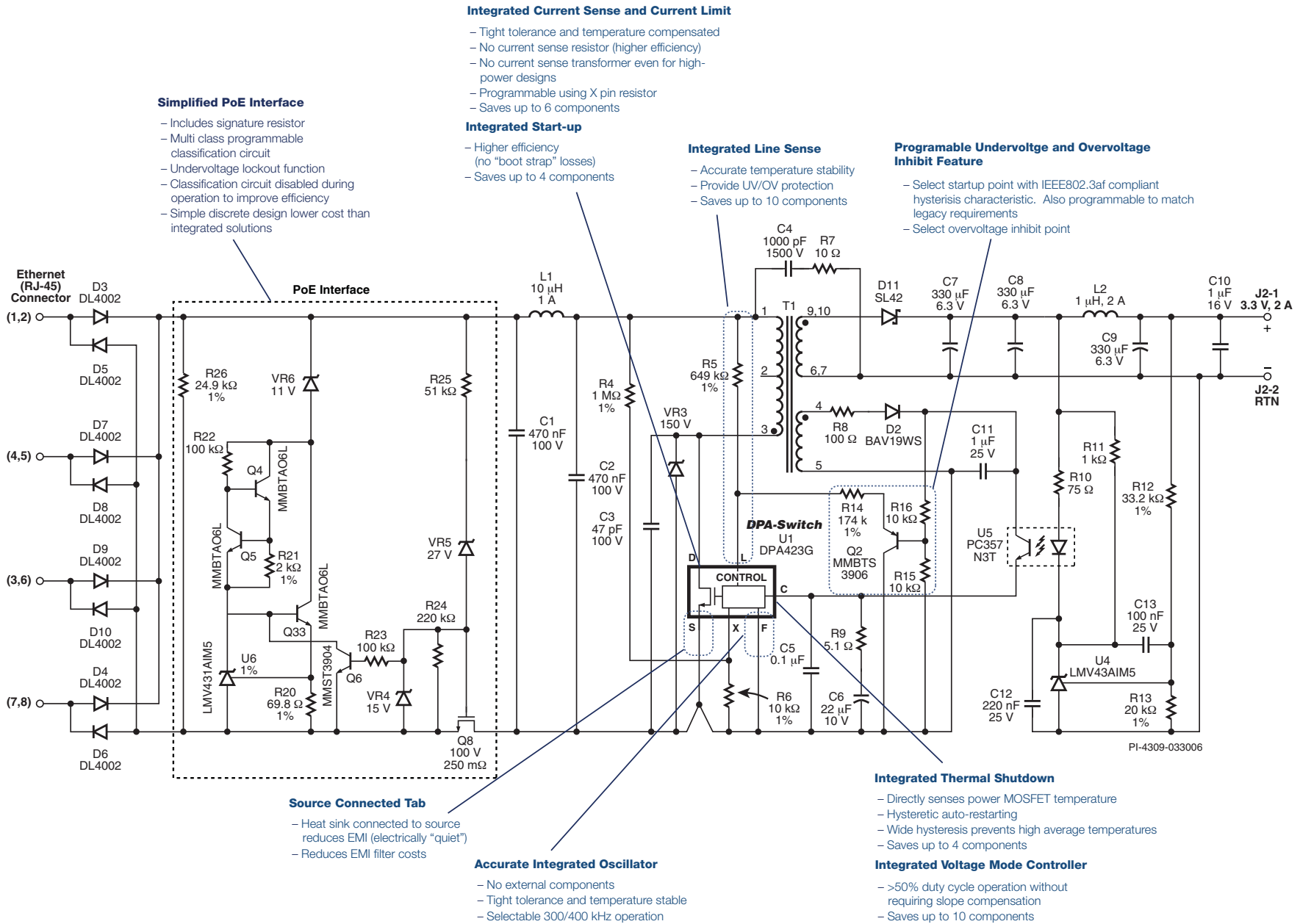

Design Tools

Reference Design Kits (RDks)

RDks include a working prototype power supply, sample devices, unpopulated pcb, data sheet, comprehensive engineering report and other related documentation.

DAK-21A	30 W, DC-DC Forward Converter
DAK-68A	6.6 W, Class 0 PoE Converter
DAK-71A	6 W, DC-DC Converter
DAK-86	6.6 W, Multi-Class Programmable PoE Powered Device



Power Supply Design Software*

With **PI Expert™** Suite, you're only "mouse clicks" away from determining the key components in your next switching power supply design, including the best Power Integrations power IC and detailed instructions for building the transformer! It's fast & easy... and best of all, **FREE!**

DPA-Switch Product and Design Collateral*

Data Sheet	DPA422-426	DPA-Switch Family Data Sheet
Application Note	AN-31	DPA-Switch DC-DC Forward Converter Design Guide
Design Ideas (2-page technical Circuit Document)	DI-24	Application: Telecom (36-75 VDC Input): 30 W, 5 V Forward Converter
	DI-25	Application: Telecom (36-75 VDC Input): 30 W, 5 V Forward Converter (Sync. Rectification)
	DI-29	Application: Telecom (36-75 VDC Input): 25 W, 7 V Flyback Converter
	DI-31	Application: Telecom (36-75 VDC Input): 70 W, 5 V Forward Converter
	DI-37	Application: Telecom (36-75 VDC Input): 16.5 W, 3.3 V Forward Converter (Sync. Rectification)
	DI-40	Application: Telecom (36-75 VDC Input): 20 W, 2.5 V Forward Converter (Sync. Rectification)
	DI-51	Application: Telecom (36-75 VDC Input): 5 W, 5 V Flyback Converter
	DI-52	Application: Telecom (36-75 VDC Input): 60 W, 12 V Forward Converter (Sync. Rectification)
	DI-53	Application: Telecom (36-75 VDC Input): 50 W, 5 V / 3.3 V Forward Converter (Sync. Rectification)
	DI-56	Application: Telecom (36-75 VDC Input): 19.2 W, ±12 V Flyback Converter
	DI-57	Application: Telecom (36-75 VDC Input): 60 W, 12 V Flyback Converter
	DI-69	Application: VoIP Phone, 15 W, 5 V / 7.5 V / 20 V Forward Converter (Sync. Rectification)
DI-70	Application: PoE VoIP Phone, 15 W, 5 V / 7.5 V / 20 V Forward Converter (Sync. Rectification)	
DI-88	Application: PoE PD Flyback Converter with Programmable Class	

* Downloadable from www.powerint.com

Worldwide Sales Support Locations

World Headquarters

5245 Hellyer Avenue
San Jose, CA 95138, USA.
Main: +1 408-414-9200
Customer Service
Phone: +1-408-414-9665
Fax: +1-408-414-9765
Email: usasales@powerint.com
info@powerint.com

Worldwide Applications

Hotline: +1-408-414-9660
Fax: +1-408-414-9760

On the Web

www.powerint.com

China (Shanghai)

Room 1601/1610, Tower 1,
Kerry Everbright City
No. 218 Tianmu Road West
Shanghai, P.R.C. 200070
Phone: +86-21-6354-6323
Fax: +86-21-6354-6325
Email: chinasales@powerint.com

China (Shenzhen)

Room A, B & C 4th Floor, Block C
Elec. Sci. Tech. Bldg.
2070 Shennan Zhong Rd.
Shenzhen, Guangdong, China 518031
Phone: +86-755-8379-3243
Fax: +86-755-8379-5828
Email: chinasales@powerint.com

Germany

Ruckertstrasse 3
D-80336, Munich
Germany
Phone: +49-89-5527-3911
Fax: +49-89-5527-3920
Email: eurosales@powerint.com

India

#1, 14th Main Road
Vasanthanagar
Bangalore-560052 India
Phone: +91-80-4113-8020
Fax: +91-80-4113-8023
Email: indiasales@powerint.com

Italy

Via De Amicis 2
20091 Bresso MI
Italy
Phone: +39-028-928-6000
Fax: +39-028-928-6009
Email: eurosales@powerint.com

Japan

Kosei Dai-3 Bldg.,
2-12-11, Shin-Yokohama, Kohoku-ku,
Yokohama-shi, Kanagawa 222-0033
Phone: +81-45-471-1021
Fax: +81-45-471-3717
Email: japansales@powerint.com

Korea

RM 602, 6FL
Korea City Air Terminal B/D, 159-6
Samsung-Dong, Kangnam-Gu
Seoul, 135-728, Korea
Phone: +82-2-2016-6610
Fax: +82-2-2016-6630
Email: koreasales@powerint.com

Singapore

51 Newton Road,
#15-08/10 Goldhill Plaza
Singapore, 308900
Phone: +65-6358-2160
Fax: +65-6358-2015
Email: singaporesales@powerint.com

Taiwan

5F, No. 318, Nei Hu Rd., Sec. 1
Nei Hu Dist.
Taipei 114, Taiwan R.O.C.
Phone: +886-2-2659-4570
Fax: +886-2-2659-4550
Email: taiwansales@powerint.com

United Kingdom

1st Floor, St. James's House
East Street, Farnham
Surrey, GU9 7TJ
United Kingdom
Phone: +44 (0) 1252-730-141
Fax: +44 (0) 1252-727-689
Email: eurosales@powerint.com

